

29.2180.01.0414 / 29.2180.01.0420

MERCEDES SPRINTER 2018 FITTING INSTRUCTIONS

NOTE

The fuel tank **will** need to be removed to access the sender unit.

Using the dimensions which are shown in (Figure 4), cut the tip of the dome off and deburr to reveal a hole in the auxiliary fuel supply port (Figure 1).

Cut the dip tube at a 45° angle to a length of 215mm (Figure 2).

Ensure that the drinking tube is straight when fitting, or that any curvature is angled down towards the bottom of the tank.

Please refer to the photograph on the right (Figure 2), which illustrates the drinking tube.

Connect the rubber fuel hose to the plastic elbow using 9mm fuel pipe clips (Figure 3).

Attach remaining assembly to the fuel metering pump and the auxiliary fuel supply port.

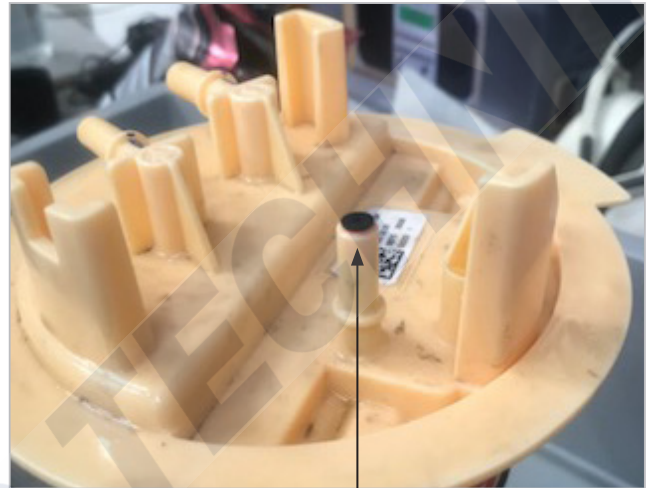

Figure 1

Auxiliary Fuel Port

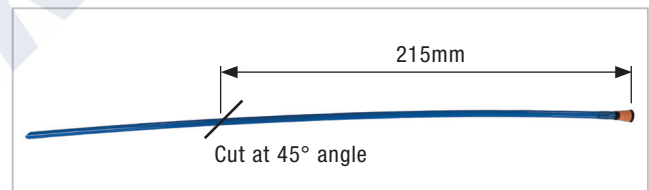

Figure 2



Figure 3

29.2180.01.0414 / 29.2180.01.0420

MERCEDES SPRINTER 2018 FITTING INSTRUCTIONS

! IMPORTANT!

The cut on the auxiliary fuel supply port must be made within the parameters that are set out below in (Figure 4). This is to ensure an airtight seal when the heaters fuel system is connected.

The rubber seal on the drinking tube should be lubricated to avoid any damage which could in turn inhibit the supply of fuel to the heater.

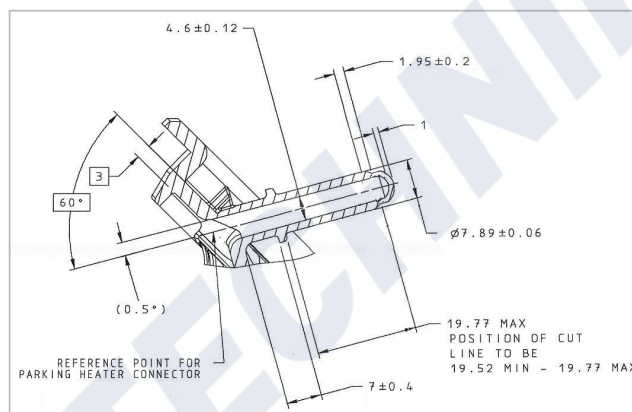

Figure 4

PART NUMBER	DESCRIPTION	QTY
10.2063.01.0098	Clip – 10mm Fuel 46010	1
25.1888.80.0102	Adaptor Fuel 5 to 3.5mm x 40mm PME	1
890.31.054	Fuel Line DIN 73378 4x1-PA12-HL-Blue	2 m
29.2100.01.7943	Transit Cork Drinking Tube	1
29.2100.01.7890	Raymond Elbow Fuel Connector	1
29.2100.17.1004	Clip – 9mm Pt. 46009 A	3
360.75.300	Hose Fuel – 3.5 x 3mm Rubber	0.05 m
360.75.300	Hose Fuel – 3.5 x 3mm Rubber	0.05 m
29.2100.20.1056	Instruction Mercedes Sprinter Fuel Kit 2018	1