

An eye on quality – a grip on efficiency

Marine climate solutions

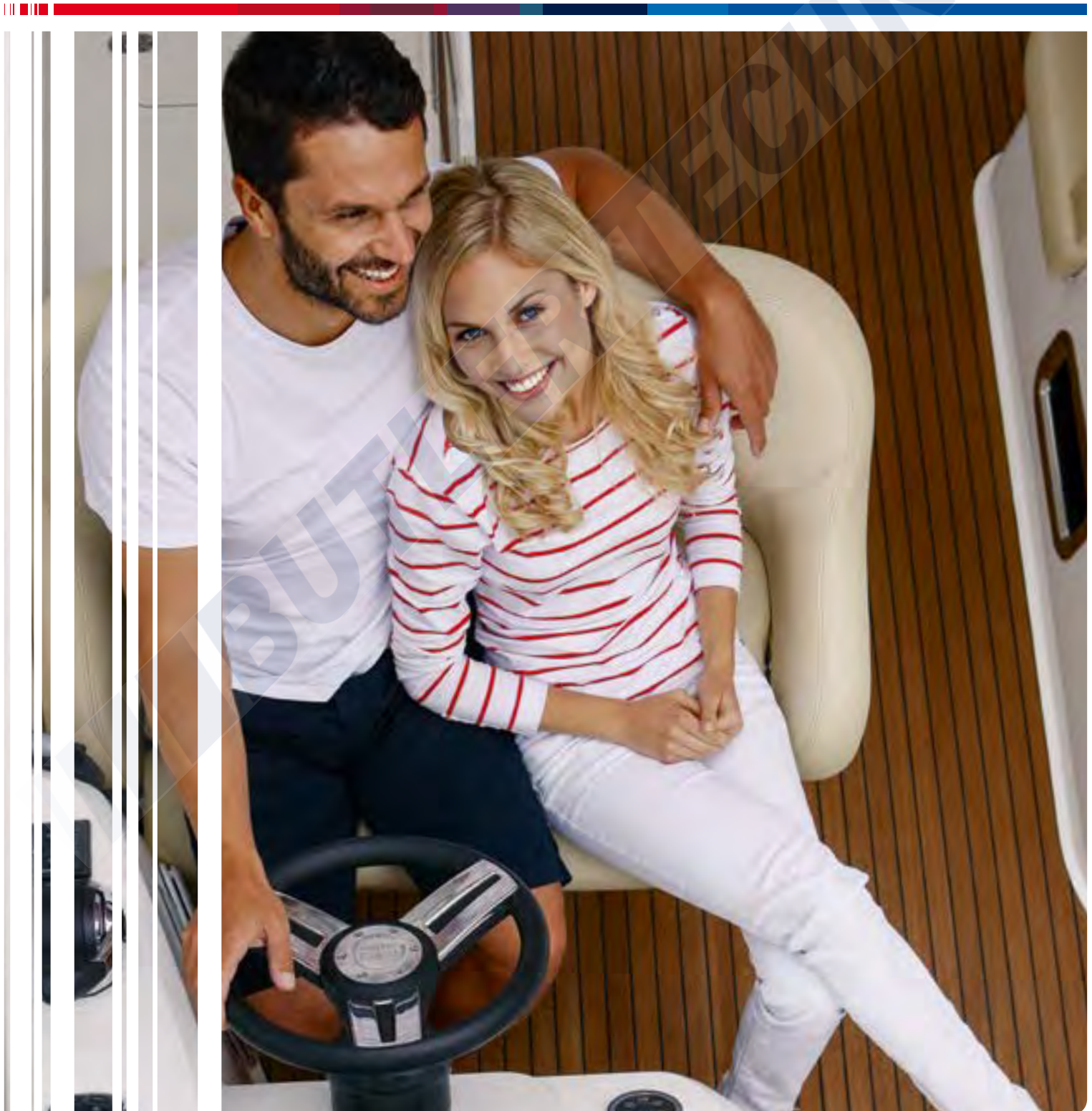

Complete climate solutions: A single expert partner for all your comfort needs.

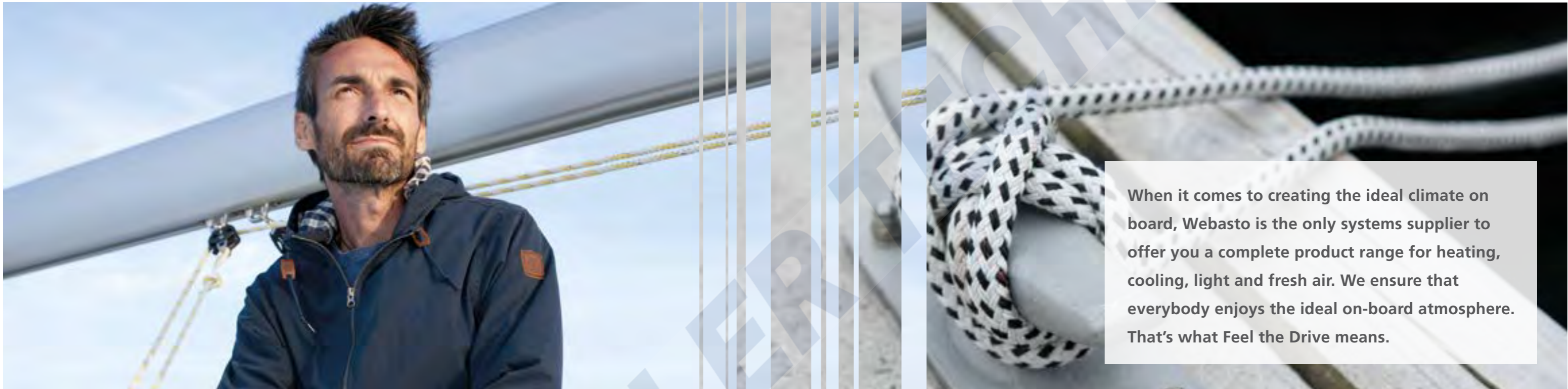

When it comes to creating the ideal climate on board, Webasto is the only systems supplier to offer you a complete product range for heating, cooling, light and fresh air. We ensure that everybody enjoys the ideal on-board atmosphere. That's what Feel the Drive means.

A global innovative partner offering quality solutions



Quality, tradition and innovation page 4



Global support services page 6

Air-conditioning solutions



Self-contained units page 18



Compact chillers page 20



Variable speed chillers page 22



Professional chillers page 24



Air handlers page 26

Water heating solutions



Water stations and boilers page 14



Cabin heating solutions



Air heaters page 10



Water heaters page 12

Integrated solutions



Integrated heating & cooling solutions page 28

Marine roof systems



Roofs page 31

Quality and automotive innovation as a path to excellence

Leveraging its core automotive technologies, Webasto has continuously enlarged its marine product portfolio in order to attain the unique position of being able to deliver complete climate control solutions for heating, cooling, light and fresh air. Marine is our passion. Just as it is yours. Enjoy the water with us.



A path of marine innovations



1950 Heaters:
Popular Webasto heaters already used in marine applications.



2006 Integrated solutions:
Combining heating & cooling into intelligent climate control solutions.

2008 Founding of Indel Webasto Marine:
Marine refrigeration products.



2011 New water stations:
High capacity central heating units for professional applications.

2013 New compact, universal chillers:
BlueCool C-Series and new air heaters



2005 Air-conditioners:
Product range extension with air-conditioners.



2007 Roofs:
Webasto presents roof platforms where size, curvature and design can be customized.



2009 High-tech controls:
Intuitive touch screen panel for the central monitoring of climate solutions.

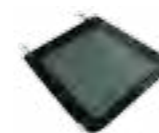

2010 New additions to our customizable roof platforms: 20-Series, 150-Series and Soft Tops.

2012 New self-contained A/C units:
BlueCool S-Series with BlueCool Expert Tool



2014 New variable speed and commercial chillers:
BlueCool V-Series
BlueCool P-Series

When our service is as boundless as your freedom: That's Feel the Drive

Global service network

- We ensure a global network with over 50 locations throughout the world via our subsidiaries, representatives and hundreds of dealers
- We guarantee an international warranty on our commissionings
- We offer global training and technical guidelines
- We guarantee fast availability of spare parts
- We are at your location with our dedicated marine service team

Global support services

- Central hotline
- Best-in-class global warranty service
- International application database and guidelines
- Standardized commissioning processes
- Dealer portal and online claim handling

Access to wide competences

- Our teams are made up of marine specialists and technical experts
- We can support our customers at all development stages from the idea down to the market introduction
- We support our customers in design, concept, product applications, product process optimization
- Our innovations are the result of open communications and close partnerships with our customers

Your best service companion: BlueCool Expert

Built-in Webasto service software suitable for all new air-conditioning units of the S-/C-/V- and P-Series.
Your best companion for easy installation, maintenance and diagnosis of the Webasto A/C systems.

- Free configuration, diagnosis and monitoring tool
- One single tool for S-/C-/V- and P-Series
- Plug-and-play USB connection to the A/C unit
- Remote troubleshooting
- Easy parameter setting
- Back-up and upload of application-specific presets
- Real-time system monitoring
- Access to data logs
- Remote activation test of A/C system components

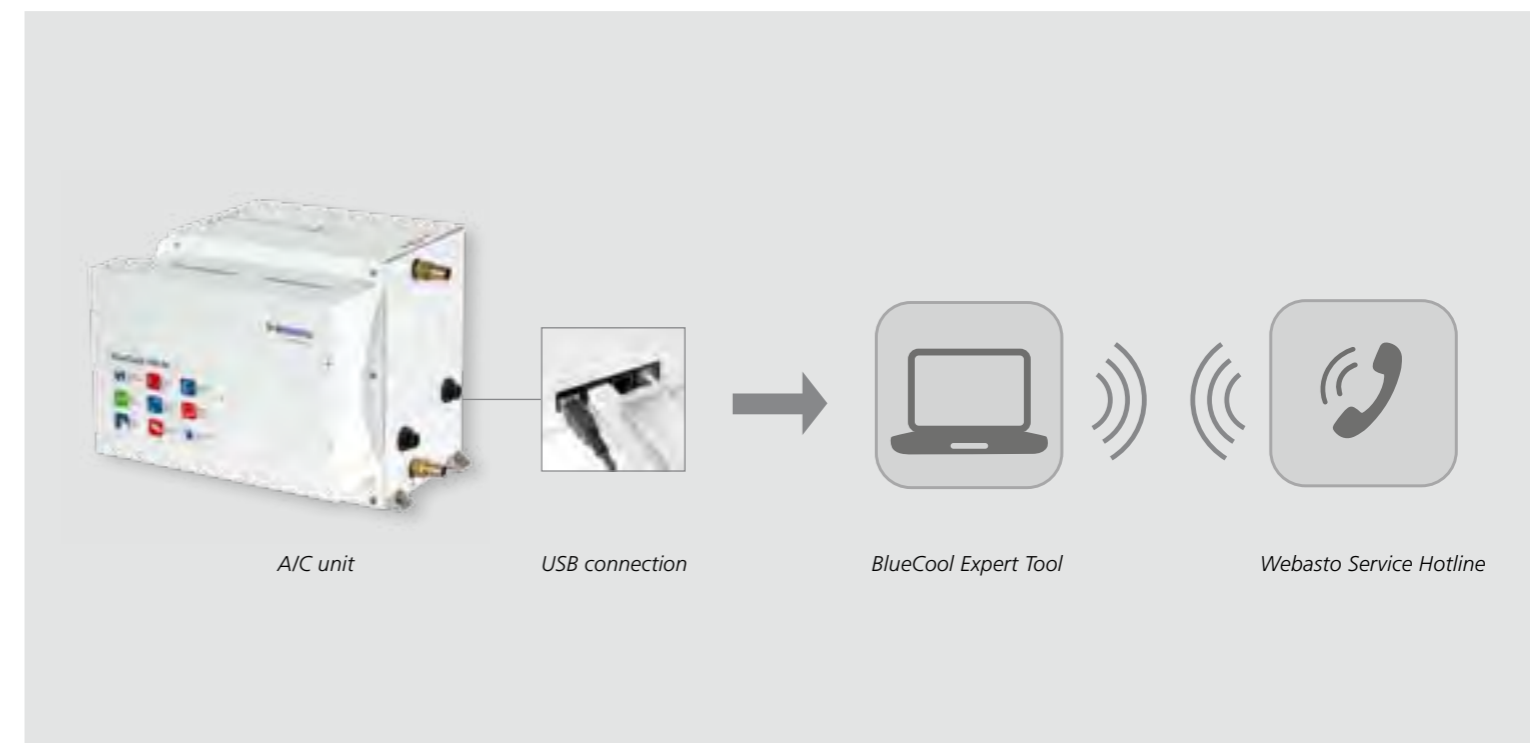

Cabin heating solutions: Extend your boating season and sense the elements

Heaters are a longstanding tradition at Webasto. For more than 80 years we have been at the cutting edge when it comes to the development of fuel-operated heating technology. Every day, leading automotive manufacturers and boat builders rely on the advanced design and technology of our Webasto heaters.

Along with specific marine installation kits we deliver innovative high-quality air and water heaters, which contribute to the enhancement of comfort on board. These two technologies provide economical, powerful and reliable

solutions to our customers, with heating outputs ranging from 2 kW up to 35 kW. There is a Webasto heating solution for every need.

Air heaters

Air heaters quickly deliver warm air throughout the boat via an air ducting system. They are very compact and easy to retrofit.

Water heaters

Water heaters are the best solution for even distribution of warmth, as you have at home. They can also be connected to domestic water boilers and to A/C chiller systems for complete climate solutions.



Air heaters

Within a short time Webasto air heaters generate a pleasantly cozy warmth on your boat. Various warm air outlets ensure good dehumidification of the vessel. Air heaters are particularly suited for sailing and motor boats up to 45 feet. Now available: New improved extra-silent marine air heater kits. They come with a very efficient heater, which has a lower electrical power consumption, but a higher heat output for applications with high back pressure.

Webasto Air Tops

- Heat output from 2 kW up to 5.5kW
- Short heat-up times thanks to effective heat output
- Complete installation kits for quick and simple retrofitting
- Effective dehumidification of cabins
- Complete independence from shore power or seawater temperature

New & improved features for the latest Air Top Evo versions:

- Very low electrical power consumption due to new Intelligent Blower Control
- New flame detection through exhaust gas temperature sensor
- Automatic cold start function for quick warm-up
- Improved combustion air intake silencer
- Vibration dampers for fuel line
- Compatible to new MultiControl digital user interface
- Very silent operation due to lower blower speed and silent fuel pump

NEW



New Air Top Evo 40/55



New MultiControl



Air Top Evo M



Rotary switch



ThermoCall App

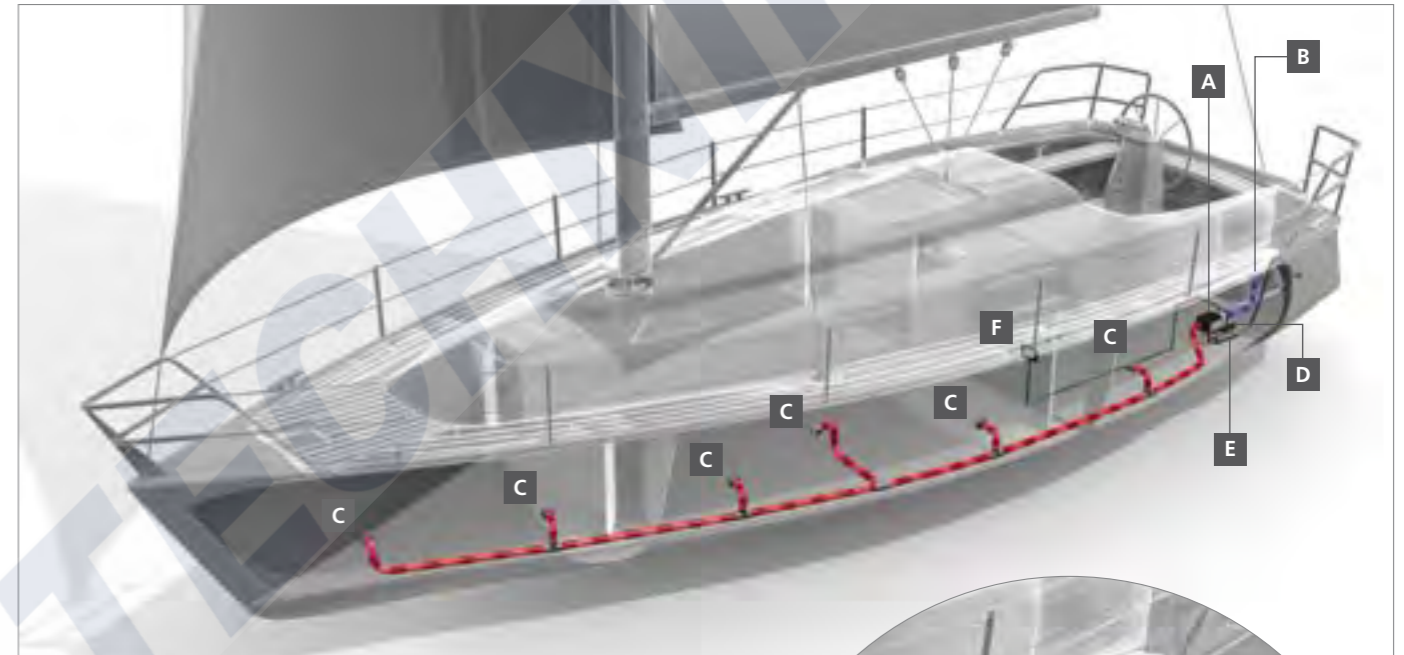

Installation example:

- A Air heater
- B Intake for fresh air from outside
- C Outlets for even distribution of air
- D Combustion-air intake
- E Stainless steel exhaust
- F Controls – simple and logical to use

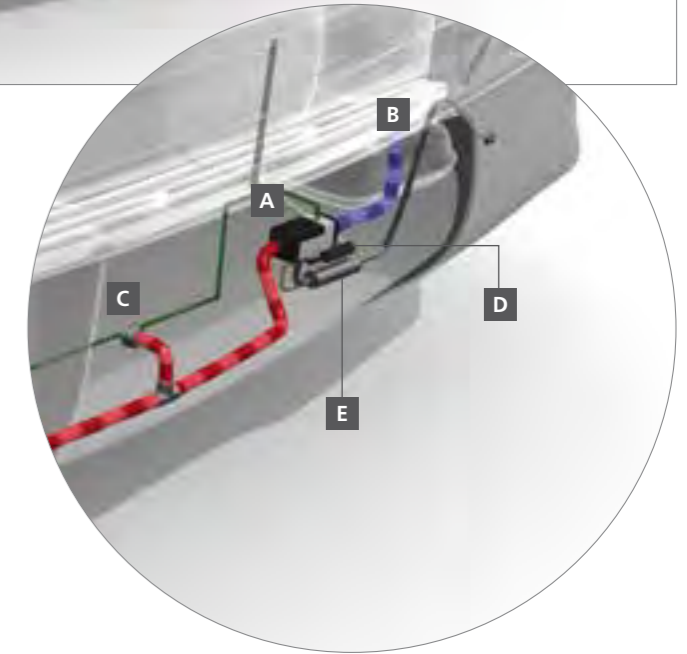

What is the Intelligent Blower Control?

Thanks to the control of more parameters (more sensors), the heating regulation can now disconnect, to a certain extent, the heating output from the blower speed, resulting in:

- Lower electrical consumption and lower noise on regular operation (lower motor speed for same heat output).
- Higher heat output availability for applications with higher back pressure.

Technical specifications:

	Air Top 2000 STC NEW	Air Top Evo 40 NEW	Air Top Evo 55 NEW
Heat output (kW) (BTU/h)	0.9 – 2.0 3,000 – 7,000	1.5 – 3.5 (4.0*) 5,100 – 12,000 (13,600*)	1.5 – 5.0 (5.5*) 5,100 – 17,000 (18,800*)
Fuel	Diesel	Diesel	Diesel
Fuel consumption (l/h)	0.12 – 0.24	0.18 – 0.43 (0.49)	0.18 – 0.61 (0.67)
Rated voltage (V)	12	12, 24	12, 24
Rated power consumption (W)	14 – 29	15 – 40 (55)	15 – 95 (130)
Dimension L x W x H (mm)	311 x 120 x 121	423 x 148 x 162	423 x 148 x 162
Net weight (kg)	2.6	5.9	5.9

* Boost power level for a maximum duration of 6 hrs (Air Top Evo 40) or 30 min (Air Top Evo 55)

Water heaters

Comfort as you know it at home. Webasto water heaters not only ensure even heat distribution in the boat, but also provide domestic hot water in connection with a water boiler. These heaters can be installed in the engine room with minimum space requirements and can be easily combined with Webasto chiller air-conditioners to form an integrated climate control system.

Webasto water heaters

- Heat output from 2.5 kW up to 35 kW
- Quiet distribution of heat through silent radiators or fan heat exchangers
- Hot water for the galley and showers
- Remote installation in the engine room saves cabin space and ensures silent operation
- Separate temperature control in every cabin
- Low fuel consumption
- Compact design
- Pre-heating of the engine possible to avoid cold starts
- Robust aluminum casing, resistant to high temperature or salt

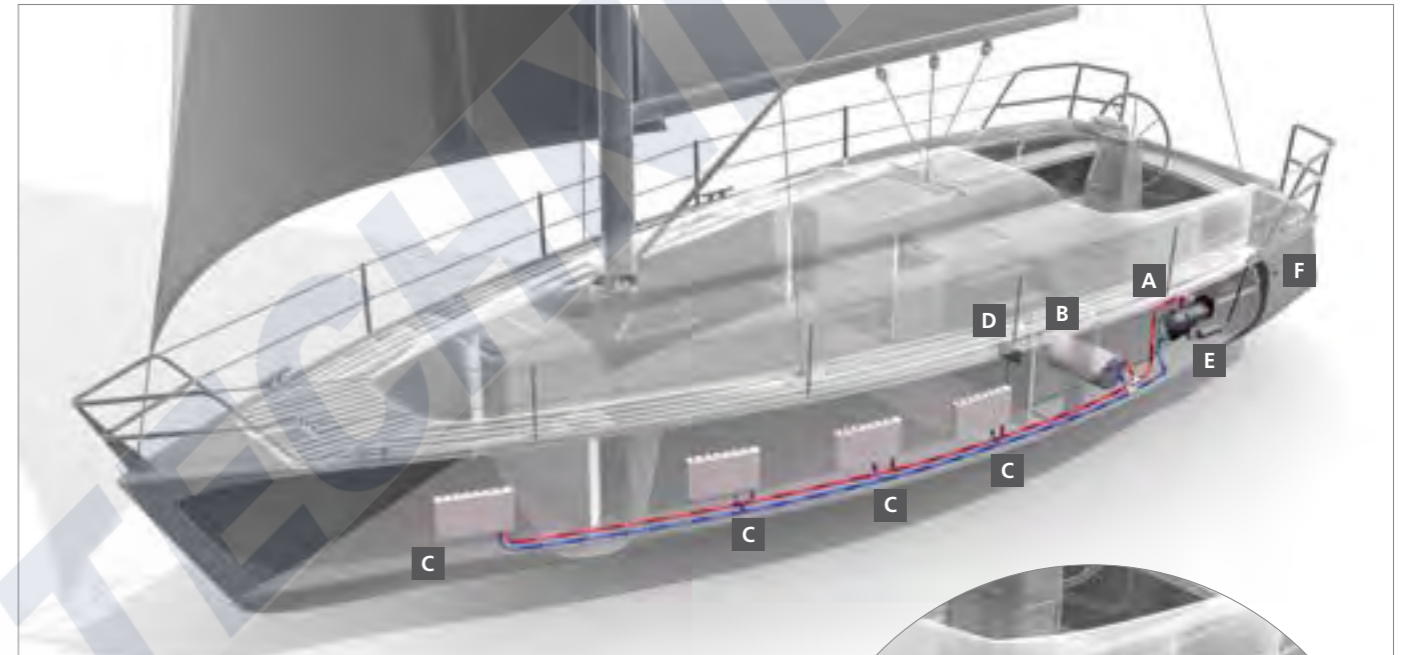

Installation example:

- A** Water heater
- B** Boiler for heating hot water
- C** One radiator for each cabin allows individual temperature control
- D** Controls – simple and logical to use
- E** Circulating pump
- F** Stainless steel exhaust

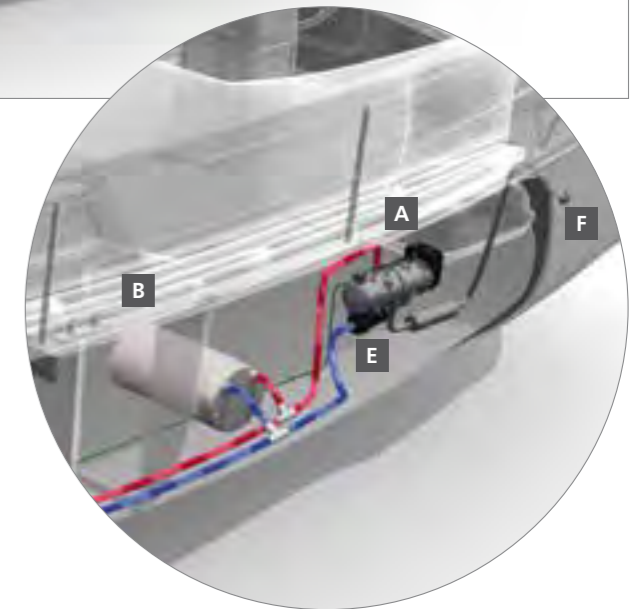

Thermo Pro 90



Thermo Top C Marine



New MultiControl



Digital Timer

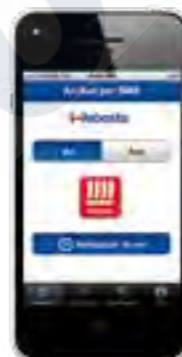

ThermoCall App

Technical specifications:

Model	Thermo Top E	Thermo Top C	Thermo Pro 50 Eco	Thermo Pro 90	DBW 2010	DBW 2016	Thermo 230	Thermo 300	Thermo 350
Heat output (kW) (BTU/h) (boost mode)	4.2 14,300	5.2 17,700	5.0 17,100	1.8 – 7.6 (9.1) 6,100 – 26,000 (31,000)	11.6 40,000	16.0 54,600	23.0 80,000	30.0 104,000	35.0 119,400
Fuel	Diesel	Diesel	Diesel	Diesel	Diesel	Diesel	Diesel	Diesel	Diesel
Fuel consumption, partial load/full load/boost (l/h)	0.3 – 0.49	0.30 – 0.61	0.3 – 0.6	0.18 – 1.08/ 1.3	1.5	1.9	2.5	3.3	3.7
Voltage (V)	12	12	24	12, 24	12, 24	12, 24	24	24	24
Power consumption (W) Partial load/full load (boost mode)	32 – 37	32 – 42	28 – 46	20 – 83 (90) 3.0 – 6.9 A (7.5) at 12 V, 1.5 – 3.5 A (3.8) at 24 V	60 5 A bei 12 V 2.5 A bei 24 V	90 7.5 A at 12 V 3.8 A at 24 V	65 2.7 A at 24 V	110 4.6 A at 24 V	140 5.8 A at 24 V
Dimension L x W x H (mm)	214 x 106 x 168	214 x 106 x 168	218 x 91 x 144	352 x 131 x 232	584 x 205 x 228	584 x 205 x 228	610 x 246 x 220	610 x 246 x 220	610 x 246 x 220
Net weight (kg)	3.2	3.2	2.5	5.3	14.5	14.5	19.0	19.0	19.0

Water stations and boilers: Hot water for long showers and warm cabins

Our marine water stations are pre-mounted "plug and heat" central heating units designed for intensive daily use, under all circumstances. For even more comfort on board, our high-quality Isotemp marine boilers provide multiple reliable solutions for all your needs with regard to hot water production.

Marine water stations

These units provide robust, sophisticated solutions for cabin heating and hot domestic water production. The dimensions for all capacity sizes are very compact, with components assembled on a steel tray and fitted in a modern casing for a very quiet operation. They are delivered with a fully insulated 20 liter stainless steel buffer tank as well as optional brackets for floor or wall mounting.



- Four versions in five capacity sizes (11.6 to 35 kW):
 - Central heating
 - Central heating and hot sanitary water through boiler
 - Central heating and hot sanitary water through integrated plate heat exchanger
 - Central heating for air-conditioner integration
- Anti-freeze mode with electric heating element in buffer tank
- Very compact dimensions
- Operating on 12/24 V
- Quick installation and easy maintenance
- Continuous production of hot water (up to 8.5 l/min. at 60°C)
- Circulation pump, fuel filter, dedicated electronics etc. already integrated

Isotemp: High-quality stainless steel water boilers

Isotemp water heaters are specifically designed for the use on yachts and boats. They deliver high water heating performance thanks to high-quality components, thick insulation and smart coil design. The slim and the basic lines are 100% stainless steel (inner tank and outside cover) and provide robust solutions in various sizes for demanding customers.



- Large range from 15 liter to 75 liter
- 3 product lines: Basic, Slim, Square
- Extra long, corrugated coils for high heat exchange efficiency
- Special 7.0 bar/100 psi safety valve; simple winter drain
- Ultra-thick insulation for lowest temperature loss
- Electrical plug and play
- Immersion heating element, especially designed to heat also the water at the bottom of the tank
- Thermostatic mixing valve available as an option
- Immersion heating elements available in 750, 1,200, 2,000 W; 2,000 W heating element is compatible on 230 V versions only

Isotemp Spa boiler: High quality and maximized customer value

The Isotemp Spa boilers are available in five different sizes ranging from 15 to 40 liter capacity. They match high marine quality standards such as a stainless steel inner tank, a robust polypropylene casing or a 6 bar safety valve.



- AISI 316 stainless steel inner tank
- 6 bar safety valve
- Optional thermostatic mixing valve
- Extra thick insulation for high performance
- Outer casing made of high quality polypropylene
- Customizable with valves, voltage and nominal power of the heating element

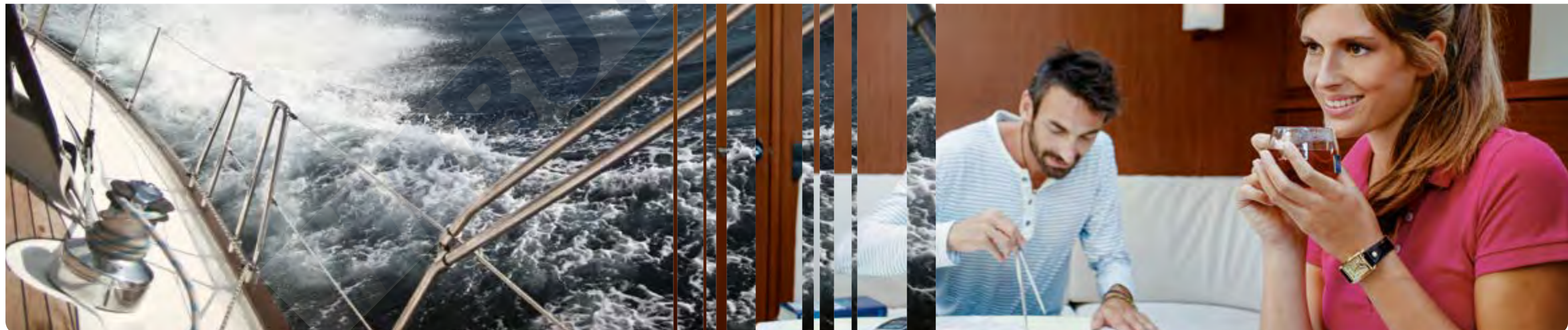



Air-conditioning solutions: Enjoy the refreshing feeling of an air-conditioned cabin

Don't you enjoy the refreshing feeling of an air-conditioned cabin after a hot sunny day on deck? With Webasto you can enjoy unforgettable moments on board. Stay refreshed wherever your journey may lead you.

Our large product portfolio of self-contained air-conditioning systems up to large inverter and chiller systems leaves nothing to be desired. With our wide power range we provide cooling capacities from 5,000 BTU/h up to 572,000 BTU/h. It is up to you to decide which technology is best suited for your boat or yacht.



Self-contained units

Self-contained cooling units are the best solution for boats with up to three cabins. Every cabin or area is equipped with one unit which is dimensioned according to the cabins cooling/heating demand.



Chiller systems

For larger boats with several cabins a central chilled water system is often the best choice. It consists of a chiller A/C unit which is typically installed in the engine room and individual air handlers for each cabin. This system allows an individual temperature control for each cabin.



Variable speed chiller units

This innovative technology with inverter driven BLDC compressors allows for modulating the cooling output in a wide range and also eliminates the starting peak current draw which enables downsizing.

Self-contained air-conditioners: BlueCool S-Series

Our self-contained air-conditioning units are the perfect solution for vessels with up to three cabins. High-efficiency compressors guarantee extra-low power consumption. These air-conditioners are very compact and thus also very easy to retrofit.

The complete range offers high performance although the units are quiet and very compact. The S-Series offer a unique feature with the BlueCool Expert Tool that is connected via a single USB cable to a PC. On site servicing and remote assistance are now a child's play.



BlueCool S-Series

Self-contained units are extremely compact. All components (compressor, condenser, evaporator and blower) required for cooling and heating a cabin, a salon, a lounge or another room are mounted on one stainless steel tray. Webasto self-contained units are available in different power ratings. This means you are sure to find the ideal system for almost all cabin sizes on a yacht that needs cooling.

Self-contained air-conditioning units:

- Stand alone unit
- Heating via integrated reverse cycle
- Extremely compact
- All components on one tray
- Seven sizes available
- Lowest power consumption
- Including electronics, blower and controls
- Evaporator temperature control in real time mode

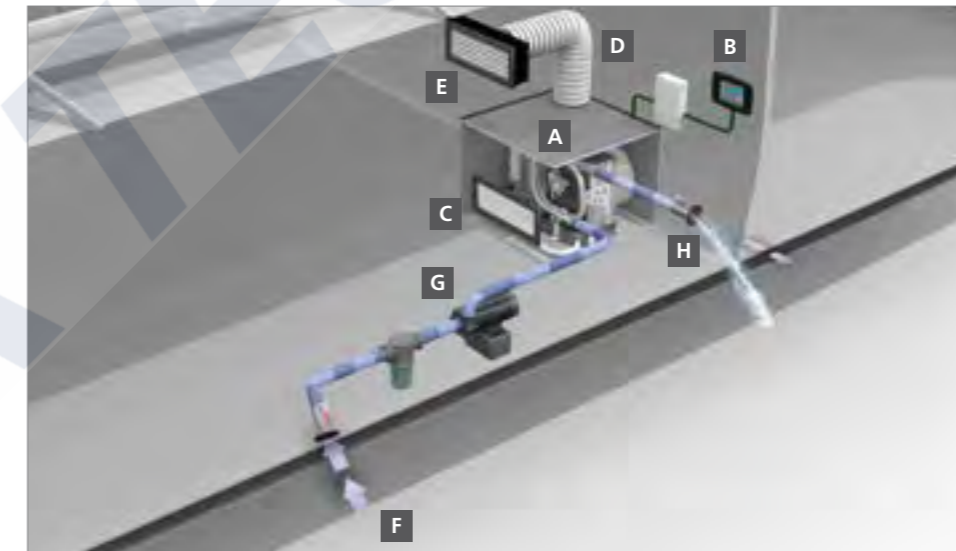

Installation example:

- A Air-conditioning unit
- B Digital display and control unit
- C Return air grille
- D Air ducting
- E Supply air grille
- F Sea water inlet
- G Sea water pump
- H Overboard discharge



The BlueCool S-Series:

- Efficiency increased by up to 15%
- Continuous operation even under tropical conditions
- Overall size is reduced by up to 20%
- New electronics with USB diagnosis
- Quiet operation
- Robust design
- Upgradable with BlueCool Soft Starts and vibration dampers
- Easy configuration, application tuning and diagnosis via BlueCool Expert tool

Technical specifications:

Model	BlueCool Classic	BlueCool S-Series					
	SC5	S8	S10	S13	S16	S20	S27
Cooling capacity* (BTU/h)	5,000	8,000	10,000	13,000	16,000	20,000	27,000
Cooling capacity* (kW)	1.5	2.4	2.9	3.8	4.7	5.9	7.9
Voltage (V)	230	230	230	230	230	230	230
Current draw running** (A)	2.1	2.4 – 3.5	2.6 – 4.0	3.6 – 6.3	4.9 – 7.2	5.9 – 8.9	7.0 – 10.5
Air flow (free blowing) (m³/h, cfm)	275 162	275 162	400 235	500 294	625 368	625 368	2 x 550 2 x 324
Sea water connection (mm/“)	16 5/8	19 3/4	19 3/4	19 3/4	19 3/4	19 3/4	19 3/4
Minimum sea water flow (l/min.)	5	8	10	12	14	17	21
Dimension L x D x H (mm/inch)	424 x 285 x 278 16.7 x 11.2 x 10.9	400 x 320 x 305 15.7 x 12.6 x 12.0	475 x 310 x 310 18.7 x 12.2 x 12.2	500 x 350 x 320 19.7 x 13.8 x 12.6	540 x 350 x 370 21.3 x 13.8 x 14.6	590 x 340 x 370 23.2 x 13.4 x 14.6	570 x 510 x 410 22.4 x 20.1 x 16.1
Blower connection (mm/inch)	100 4	100 4	100 4	125 5	125 5	125 5	2 x 125 2 x 5

* BTU/h are based on 7°C evaporating temperature and 38°C condensing temperature
 ** Amperage values depend on compressor load. Max values stated for tropical conditions at 230 V/50 Hz

Compact chiller systems: BlueCool C-Series

The chiller air-conditioning systems are available in a large power range to fit into any boat or superyacht. The systems are available customized or modular for special applications. These units offer the best cabin comfort because they enable you to provide the required amount of cooling and heating wherever needed. They are also the ideal basis for our integrated systems (see page 28).

For smaller chiller systems up to 108,000 BTU/h the BlueCool C-Series is the perfect choice. For larger systems our professional chiller series BlueCool P-Series offer capacities up to 572,000 BTU/h.



BlueCool C-Series

The BlueCool C-Series:

- Improved performance and up to 15% higher efficiency
- Continuous cooling capacity even in tropical conditions
- Even more compact design
- Easy configuration, application tuning and diagnosis via BlueCool Expert tool
- Optional CAN-Bus for optimized adaptation to boat systems
- Compressor noise is reduced by up to 25%
- Easy sea water and chilled water connections at one side
- Strong stainless steel tray and condensate drain
- Cooling and heating via reverse cycle function as standard
- High quality epoxy paint protection
- Upgradable with BlueCool Soft Starts and vibration absorbers
- Universal 50/60 Hz operation compatibility and tropicalized units

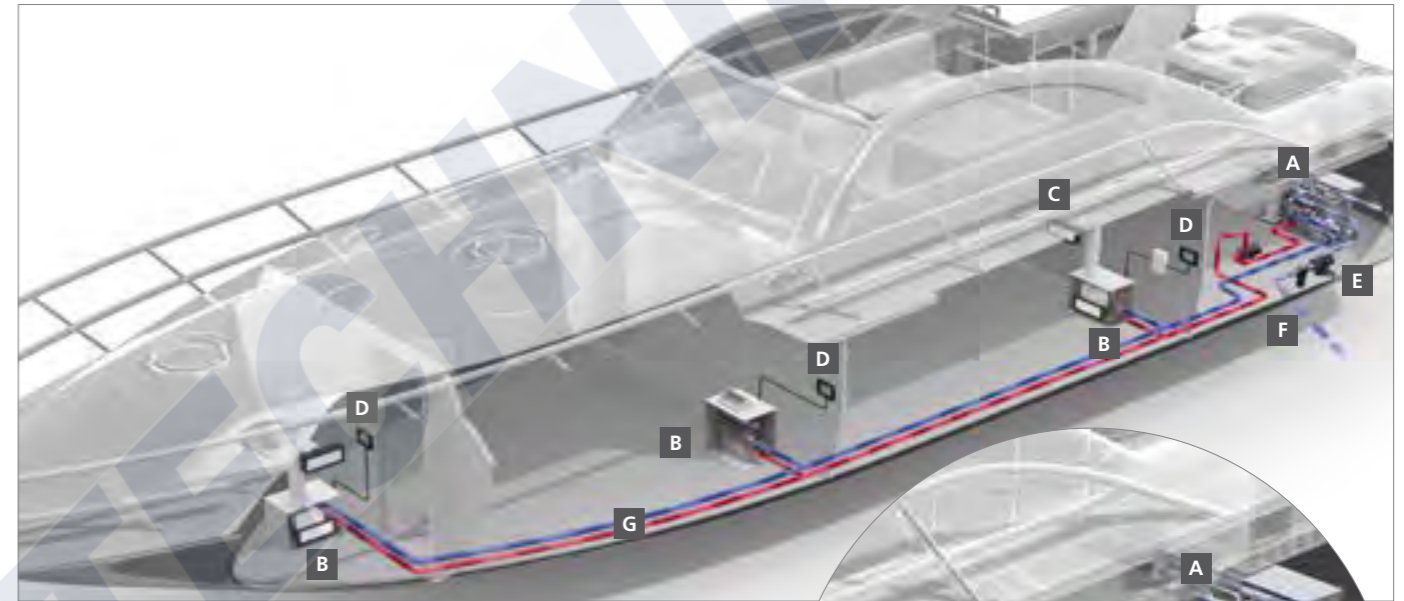

Installation example:

- A** Chiller A/C unit in the engine room
- B** Fan-type air handler
- C** Cold-air outlets
- D** Controls – simple and logical to use
- E** Sea water pump
- F** Sea water cooling circuit
- G** Chilled water circuit

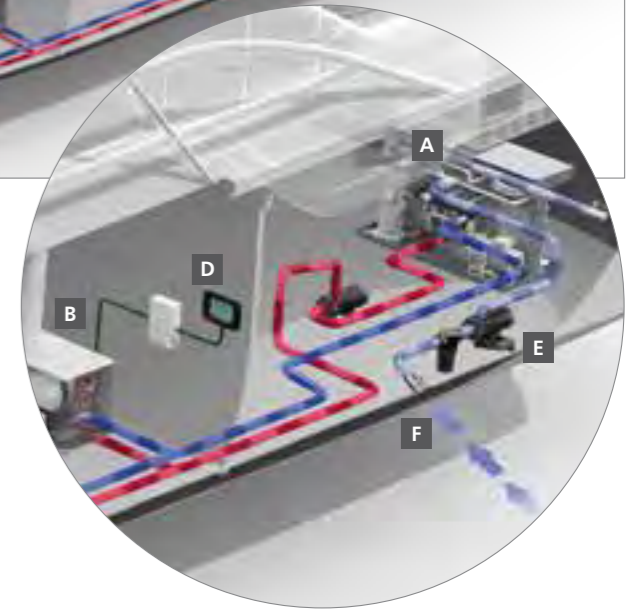

Also discover our added-value accessories for S-, V- and C-Series like our BlueCool Soft Starts:

- Reduction of electrical starting peak up to 70%
- Fully 50/60 Hz compatible for worldwide application
- Self-adjusting software adapts to compressor type and frequency input
- Easy to install and to retrofit in BlueCool electrical boxes

Technical specifications:

Model	BlueCool C-Series							
	C16 M	C20 M	C27 M	C32 T	C40 T	C55 T	C81 R	C108 Q
Cooling capacity* (BTU/h)	16,000	20,000	27,000	32,000	40,000	55,000	81,000	108,000
Cooling capacity* (kW)	4.7	5.9	7.9	9.4	11.7	16.1	23.7	31.7
Voltage (V)	230	230	230	230	230	230	230	230
Current draw running** (A)	4.4 – 6.0	6.9 – 8.0	8.6 – 9.2	8.8 – 12	14 – 16	17 – 18	26 – 28	34 – 37
Dimension L x D x H (mm)	390 x 290 x 355	440 x 330 x 360	440 x 330 x 395	590 x 410 x 500	590 x 410 x 500	590 x 410 x 550	850 x 430 x 550	860 x 640 x 600
Weight (kg)	34	37	45	65	70	86	119	173

* BTU/h are based on 7°C evaporating temperature and 38°C condensing temperature
 ** Amperage values depend on compressor load. Max values at tropical conditions stated for 230 V/50 H

General note: Values in this table given for 50 Hz only. 60 Hz data available on request.

Variable speed chiller systems: BlueCool V-Series

The new V-Series introduces a ground-breaking universal chiller system that addresses the issues most frequently encountered by the marine. This very innovative system runs on variable speed compressors controlled with inverter technology during the starting phase and continuously throughout operation. This leads to smooth and silent operation with no electrical starting peak, which enables downsizing of the genset that results in cost-savings. The self-adapting control logic allows the unit to operate smoothly worldwide in all climates and frequencies.

NEW



New BlueCool V-Series

The new BlueCool V-Series V50 M:

- Large power modulation range: 8,500 – 50,000 BTU/h
- Variable speed BLDC compressors controlled by inverter technology
- Zero electrical starting peak
- Super quiet operation
- High system availability via dynamic control of HP/LP boundary conditions
- Adjustable amperage draw
- Preventive maintenance monitoring system
- Condensate-free
- Easy installation and maintenance
- Low service and operation costs
- Light and compact
- Integrates Webasto's BlueCool Expert diagnosis and set up tool
- Silent blocks available as an option

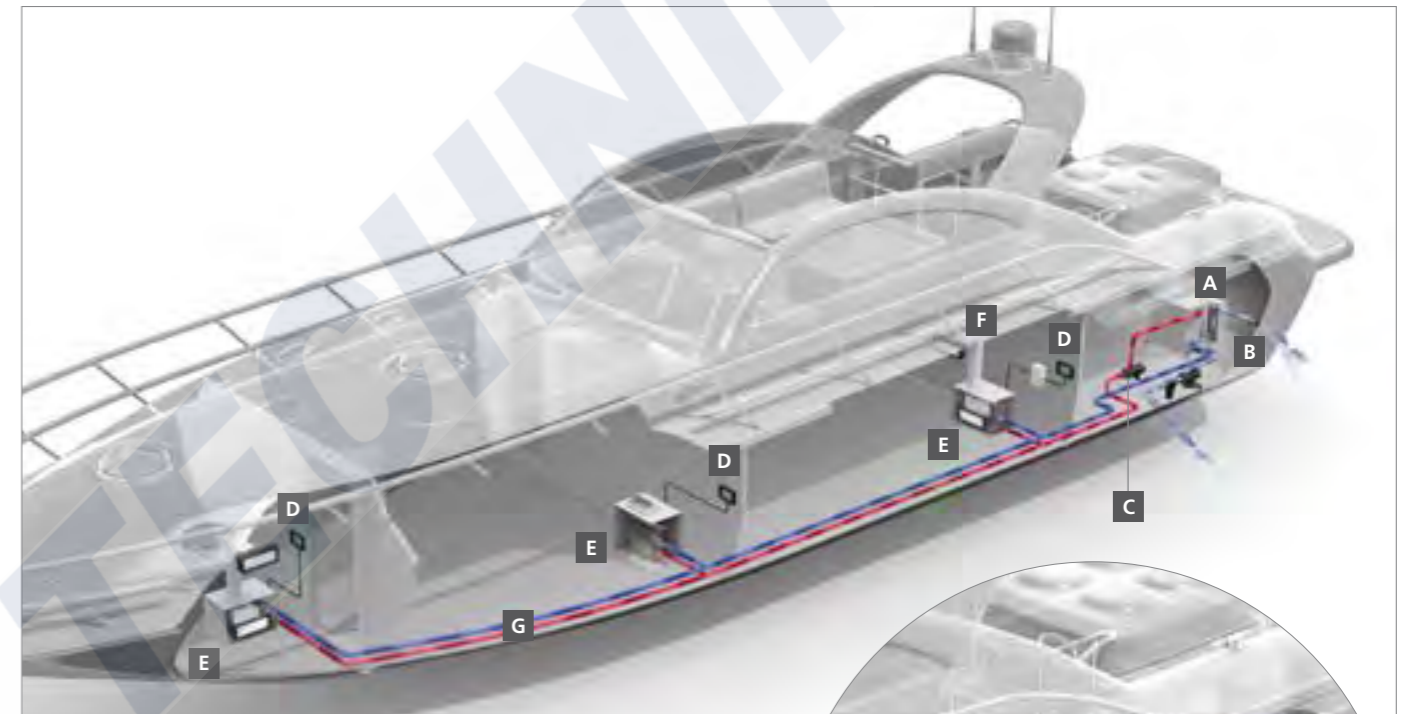

Installation example:

- A** BlueCool V-Series
- B** Sea water cooling circuit
- C** Circulating pump
- D** Control
- E** Fan-type air handler
- F** Cold-air outlet
- G** Chilled water circuit

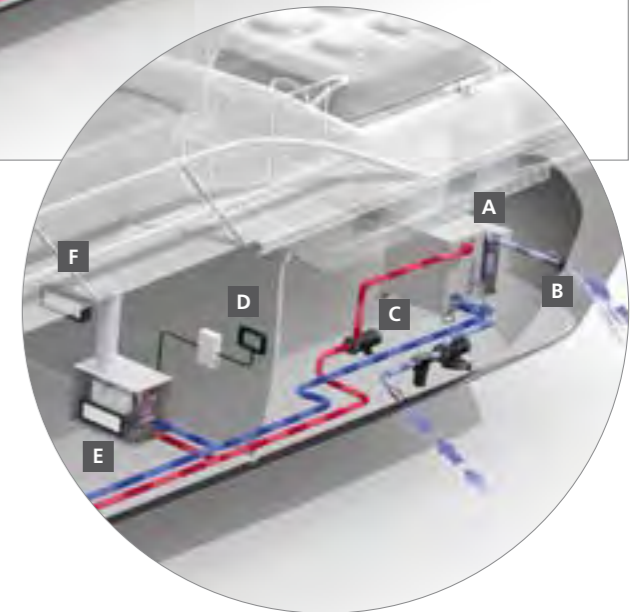

Model	BlueCool V-Series NEW V50 M
Cooling capacity* (BTU/h)	8,500 – 50,000
Cooling capacity* (kW)	2.5 – 14.6
Voltage (V)	230
Frequency ++ (Hz)	50/60
Current draw running** (A)	2.5 – 15* (max. 17)
Current draw Eco 1 Mode	2.5 – 8* (max. 12)
Current draw Eco 2 Mode	2.5 – 5* (max. 8)
Current draw start (A)	2.5
Dimensions unit L x D x H (mm)	567 x 340 x 510
Dimensions electronic box L x D x H (mm)	560 x 192 x 435
Dimensions unit incl. box L x D x H (mm)	607 x 530 x 510
Weight core unit (kg)	47
Weight electronic box (kg)	15

* BTU/h are based on 7°C evaporating temperature and 38°C condensing temperature
 ** Amperage values for core unit depend on compressor load. Max values at tropical conditions at 230 V/50 Hz
 ++ BlueCool V-Series systems are tested and approved by Webasto for 50/60 Hz operation.



BlueCool V-Series V50 M:
 IBEX Product Innovation
 Award Winner 2014.

Professional chiller systems: BlueCool P-Series

The new professional chiller systems for medium to large boats and superyachts are highly customizable to the demands of shipyards and national legislation. In addition to a wide range of cooling capacities, many options can be selected to customize the chiller to your needs. Configure your perfect professional chiller – customized to your needs.

NEW

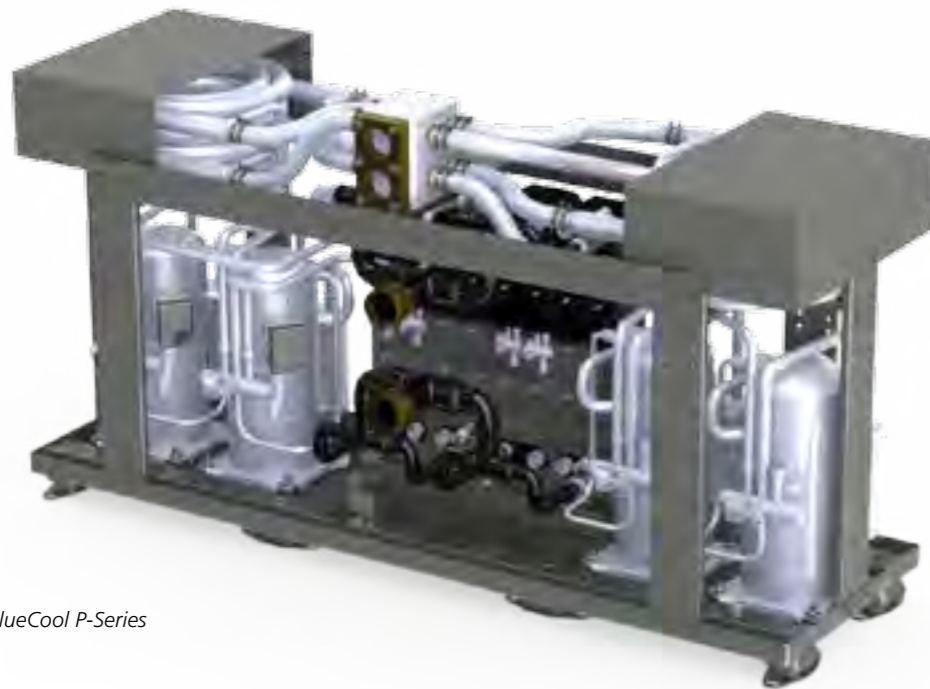

New BlueCool P-Series

The new BlueCool P-Series:

- Professional chiller system for medium to large boats and superyachts
- Highly customizable chiller series with large range of 30,000 – 572,000 BTU/h to adapt to cooling demand
- Successor of our BlueCool Premium scroll compressor range for high reliability
- Multiple compressor units with independent cooling circuits for high availability
- Range extension with 8 new models
- Improved electronics – new electronic box with easier access to components – new PCB with increased circuit protection, now also fulfilling highest EMC standards EN 60945
- Easy configuration, application tuning and diagnosis via BlueCool Expert tool
- Optional CAN-Bus for integration into boats central monitoring systems
- Unique thermostatic advance function for power output continuously adapted to cooling demand
- Redesigned trays for easier mounting of silent blocks to reduce vibrations
- Electrical systems can be upgraded to customer needs with PRO box or fulfilling MCA requirements

Discover the possibilities!

Configure your chiller system in 6 main steps:

1. Voltage

- All P-Series chillers are available as 400 V/ 3-phase version. On most models 208 V/3-phase or 230 V/single phase is available as well.

2. Cool only version

- For regions where heating is not required some units are available as cool only version.

3. Tropical version

- For high sea water temperatures > 32°C, a tropical chiller version with enlarged condensers should be selected to avoid high pressure cut-outs.

4. Soft Starts

- In order to reduce the amperage draw at compressor start a soft start may be chosen as an option.

5. Electrical updates

- Webasto offers a wide variety of electrical options which enhance the operation and service comfort or ease the electrical installation.

6. Silent blocks

- Silent blocks may be mounted between the chiller unit and the hull of the boat to reduce structurally caused vibrations being transferred from the chiller unit into the boat.

Technical specifications:

Type	BlueCool P-Series NEW			
	P30 Mono to P126 Mono	P60 Twin to P120 Twin	P72 TRI to P252 TRI	P96 QTT to P572 QTT
Cooling capacity (BTU/h)	30,000 to 126,000	60,000 to 120,000	72,000 to 252,000	96,000 to 572,000
Supply voltage (V)	230/208/400	230/208/400	230/208/400	230/208/400
Current draw running (A)	6.8 – 12 (230 V)	14 – 25 (230 V)	17 – 37 (230 V)	22 – 38 (230 V)
	5.0 – 17 (208 V)	10 – 33 (208 V)	12 – 72 (208 V)	18 – 96 (208 V)
	2.9 – 12 (400 V)	5.8 – 12 (400 V)	6.8 – 25 (400 V)	6.8 – 53 (400 V)
Net weight (kg)	55 to 110	90 to 160	90 to 260	150 to 725

For detailed information on our complete product portfolio please refer to our marine catalog.



Air handlers: Broadest range to fit any demand

Webasto offers the widest range of air handlers to fit any demand on capacity or space limitations. All air handlers have insulated condensation trays and you can choose from Compact, Cross flow and SlimLine air handlers. In addition to horizontal and vertical layouts, accessories such as bleeder kits or the electronic silencer for significant reduction of blower noise can fine-tune your applications.



The electronic silencer:

- Significant reduction of blower noise in low speed levels, making the air handler whisper quiet
- Works with all our air handler models due to simple integration into the power supply
- Easy to install and retrofit as an upgrade
- Allows fine-tuning of installed applications where necessary
- Further noise reduction can be obtained by using our new extra-silent air ducting

Compact	SlimLine / V	Cross flow / H
 <p>Compact air handler 4,500 BTU/h – 48,000 BTU/h</p>	 <p>SlimLine air handler / vertical 4,500 BTU/h – 24,000 BTU/h</p>	 <p>Cross flow air handler / horizontal 4,000 BTU/h – 12,000 BTU/h</p>
Cross flow / V	SlimLine / H	
 <p>Cross flow air handler / vertical 4,000 BTU/h – 12,000 BTU/h</p>	 <p>SlimLine air handler / horizontal (top view) 4,500 BTU/h – 24,000 BTU/h</p>	

BlueComfort integrated solutions: Full performance in all weather conditions

The BlueComfort Premium system integrates a chilled water air-conditioner unit and a diesel-operated heater into one system. The use of a water heater ensures full heating performance, even at low seawater temperatures, when the reverse cycle of an air-conditioner gets inefficient (below 6°C). In this integrated system the same water piping, air handlers, air ducting and cabin temperature control modules are used for both heating and A/C operation. The system is controlled via one control panel, making the activation of A/C or heater totally transparent to the end-user.

BlueComfort Premium DeLuxe integration

It is possible to also integrate a hot water boiler into the heating circuit to provide hot water wherever needed independently of the boat engine running or the availability of 230 V mains. Please refer to the Webasto marine catalog for more details.

Example of a Webasto BlueComfort Premium Basic integration

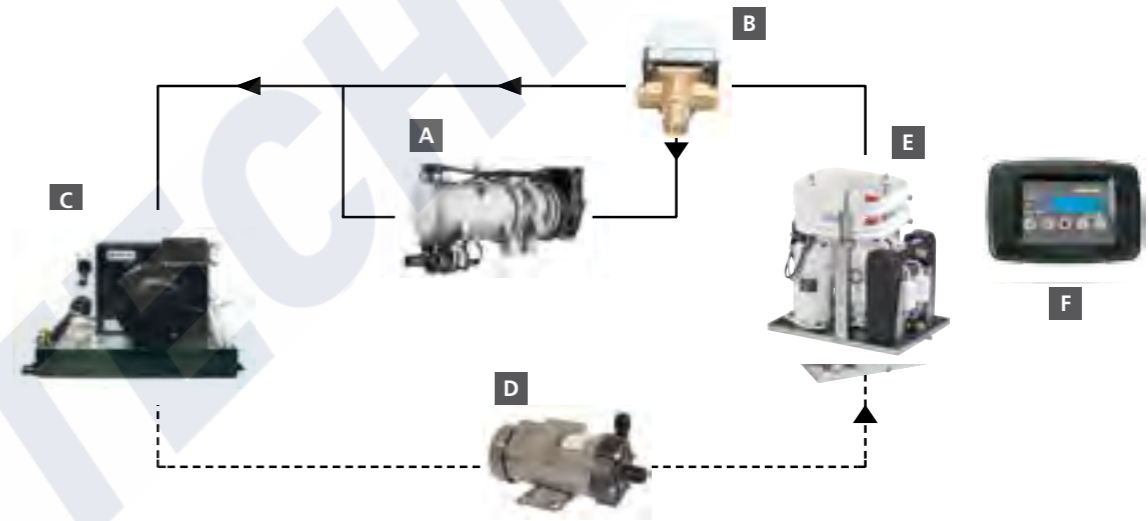

- A** Water heater produces hot (60°C) water when system switches to heating
- B** 3 way valve switches between cooling or heating loop
- C** Air handler warms up or cools down the cabin air
- D** Water pump circulates the water
- E** A/C chiller unit cools down the water when system switches to cooling
- F** Chiller control controls the complete A/C system and the water heater; starts the compressor when cooling is necessary; starts the heater when heating is necessary

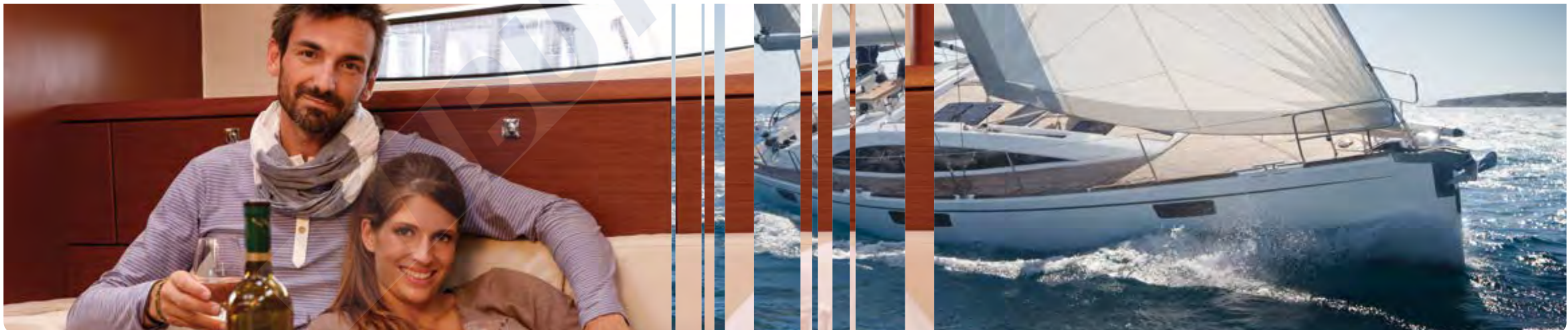

The sky so close: Opening new horizons with our customizable roof platform solutions

Light and fresh air are essentials aboard a boat or yacht. Webasto offers you a wide range of marine roof solutions, to be customized to the shape, size and design of your deck. They benefit from Webasto's worldwide technological leadership in automotive sunroofs.

On top of this broad selection of roof solutions, Webasto's engineering services can do even more for your exclusive, unique roof project. Large moveable surfaces of all kinds and sizes are our mission. Webasto has 30 years' experience in advanced automotive roof systems which we apply to marine: kinematics, advanced materials, water management and sealing systems. We turn your ideas into reality and guarantee high quality and outstanding product know-how.

Webasto offers small series manufacturing at full series quality levels: Process-oriented assembly operations, from the pilot line through the design check to series production. Phased project approach and joint teams enable know-how transfer to your engineers.

The success of our projects is based on three fundamental elements:

Product visualization: Translate ideas into visual concepts.
Phased project approach allows frequent evaluation and limits the customers' risk.

Product development: Translate visual into technical concept.
Joint teams require strong customer involvement (marketing, R&D, manufacturing).

Product validation: Prepare drawing package for suppliers and assembly.
Highly valuable know-how transfer ensures best outcome of the project investments at every stage.

There is a roof for even the most demanding requirements

The 20-Series



Economical and robust roof for more light on board

A very economical manual sliding roof for more light and fresh air on board. The roof is fully tested and pre-assembled including all necessary hardware allowing quick and easy installation.

- Standard roof with large opening
- Watertight sealing
- Robust and proven construction
- Manual operation
- Stepless locking system

The 40-Series



Standard electric marine sliding sunroof

This roof platform offers a sleek, low profile design to be able to fit into smaller boats. The roof is electrically operated, extremely quiet, and is delivered fully assembled, tested and ready to be installed.

- Attractive design with safety glass
- Watertight sealing
- Fast and simple installation
- Robust and quality-tested design
- Optional fixed glass panel for panoramic views

The 60-Series



The easy, ready to be mounted solution

This series offers multiple customization options for a perfect fit. The roof is delivered fully tested, pre-assembled and ready-to-be-mounted at the shipyard thus resulting in significant cost saving for the boat builder.

- Customizable roof system
- Watertight sealing
- Robust and proven construction
- Electrical operation
- Smooth automotive style mechanism

The 80- & 120-Series



Roof design for extra large glass and composite panels

A completely dedicated roof solution whereby application engineering and a close cooperation with the shipyard is required. The roof is delivered fully tested, pre-assembled and ready-to-be-mounted.

- Fully integrated roof design
- Watertight sealing
- Very large dimensions and opening
- Selection of different panel materials
- Double curved solution is possible

The 150-Series



Exclusive double-curvature roof models

A perfect solution for demanding roof projects. The fully integrated roof consists of a moving and a fixed panel. The panels are fully flush and the double curvature allows extra ordinary design possibilities.

- Fully integrated roof design
- Watertight sealing
- Selection of different panel materials
- Extra large dimensions and opening
- Sliding panel is tilting at rear and front side

The Soft Top



Exclusive automotive style folding roof

The Soft Top benefits from the automotive folding roof technology resulting in an elegant and luxurious design. The system is available in 3 sizes and the fabric can be provided in various colors.

- Exclusive automotive style folding roof
- 3 Standard sizes or dedicated dimensions
- Various colors for the fabric
- Fabric on the inside and outside
- Smooth automotive-style mechanism

Marine is our passion – just as it is yours

Our mission is to enable you to benefit from new innovations that result from high investments in our core technologies across various business segments. Our goal is to create the perfect atmosphere on board. That's what drives us. That's Feel the Drive.



Maritimo
Webasto marine roof 60-Series



Jeanneau Prestige 60S
Webasto marine roof 80-Series



Bavaria Vision 46
Webasto Air Top Evo 40 & BlueCool self-contained units



Moonen 84'
Webasto BlueCool Premium, 126,000 BTU/h chiller air-conditioner



Bavaria Virtess 420
Webasto marine roof 120-Series



For more than 75 years, the Webasto group has continued to set new technological standards – in both the original equipment sector and the aftermarket. As one of the 100 biggest suppliers in the automotive industry worldwide, we develop and produce roof, convertible as well as heating, cooling and ventilation systems. Our products help provide a better atmosphere on the road, more comfort and security, as well as increased efficiency for cars, commercial and special vehicles, motor homes and boats. An outstanding network of production facilities and dealers guarantees high-quality products, installation standards and services worldwide.