

E7193

Ford Transit E7193 Fitting Instructions

Note:

The fuel tank **will** need to be removed to access the sender unit.

Using the dimensions which are shown in (Figure 4), cut the tip of the dome off and deburr to reveal a hole in the auxiliary fuel supply port (Figure 1) and insert the drinking tube into the auxiliary fuel port.

Please refer to the photograph on the right (Figure 2) which illustrates the drinking tube.

Connect the rubber fuel hose to the plastic elbow using 9mm fuel pipe clips (Figure 3).

Attach remaining assembly to the fuel metering pump and the auxiliary fuel supply port.

Important

The cut on the auxiliary fuel supply port must be made within the parameters that are set out below in (Figure 4). This is to ensure an airtight seal when the heaters fuel system is connected.

The rubber seal on the drinking tube should be lubricated to avoid any damage which could in turn inhibit the supply of fuel to the heater.



Figure 1

Auxiliary Fuel Port



Figure 2

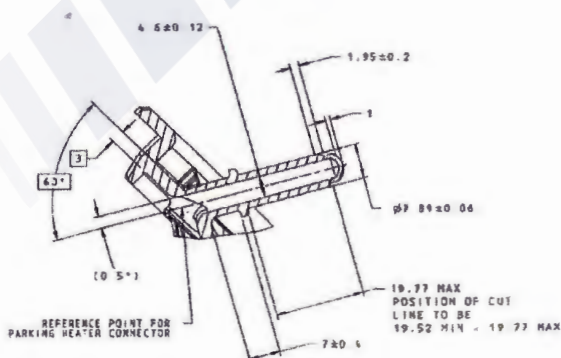

Figure 4



Figure 3