

**Wasserheizgeräte  
Water Heaters  
Appareils de chauffage à eau**

**Einbauanweisung  
Installation instructions  
Notice de montage**

**DBW 2010 / 2016**

mit Steuergerät 1553  
with Control Unit 1553  
avec organe de commande 1553

**Inhaltsverzeichnis**

1	Gesetzliche Bestimmungen für den Einbau	1
2	Verwendung / Ausführung	3
3	Einbau	4
4	Einbaubeispiel für DBW 2010 / 2016	7
5	Einbau Umwälzpumpe	8
6	Anschluss an das Kühlsystem des Fahrzeugs	9
7	Brennstoffversorgung	10
8	Brennluftversorgung	12
9	Abgasleitung	13
10	Elektrische Anschlüsse	14
11	Erstinbetriebnahme	22
12	Störungen	23
13	Technische Daten	24

**Sommaire**

1	Dispositions légales concernant le montage	53
2	Utilisation / version	55
3	Installation	56
4	Exemple d'installation pour le DBW 2010 / 2016	59
5	Installation de la pompe de circulation	60
6	Raccordement au circuit de refroidissement du véhicule	61
7	Alimentation en carburant	62
8	Alimentation en air de combustion	64
9	Conduite d'échappement	65
10	Branchements électriques	66
11	Première mise en service	74
12	Pannes	75
13	Caractéristiques techniques	76

**Table of contents**

1	Statutory regulations governing installation	27
2	Use / version	29
3	Installation	30
4	Installation example for DBW 2010 / 2016	33
5	To install the circulating pump	34
6	Connection to the vehicle cooling system	35
7	Fuel supply	36
8	Combustion air supply	38
9	Exhaust pipe	39
10	Electrical connections	40
11	Initial start-up	48
12	Troubleshooting	49
13	Technical data	50

## 1 Statutory regulations governing installation

### 1.1. Statutory regulations governing installation

Type approvals according to ECE-R 10 (EMC) and ECE-R 122 (Heater) exist for the DBW 2010 / DBW 2016 heaters.

See Chapter 13, "Technical data" for the approval number.

Installation is governed above all by the provisions in Part I and Annex 7 of Directive ECE-R 122.

#### NOTE:

**The provisions of these Directives are binding within the territory governed by EU Directive 70/156/EEC and/or EC/2007/46 (binding for new vehicle types as of 29/04/2009) and should also be observed in countries in which there are no special regulations!**

#### IMPORTANT:

Failure to follow the installation instructions and the notes contained therein will lead to all liability being refused by Webasto. The same applies if repairs are carried out incorrectly or with the use of parts other than genuine spare parts. This will result in the invalidation of the type approval for the heater and therefore of its **homologation / ECE type licence**.

### 1.2. Extract from directive ECE-R 122 Part I and Annex 7

Start of extract.

#### Part I

#### 5.3 Vehicle Installation Requirements for Combustion Heaters and for Electric Heaters

##### 5.3.1 Scope

5.3.1.1 *Subject to paragraph 5.3.1.2, heaters shall be installed according to the requirements of paragraph 5.3.*

5.3.1.2 *Vehicles of category O having liquid fuel heaters are deemed to comply with the requirements of paragraph 5.3.*

##### 5.3.2 Positioning of heater

5.3.2.1 *Body sections and any other components in the vicinity of the heater must be protected from excessive heat and the possibility of fuel or oil contamination.*

5.3.2.2 *The heater shall not constitute a risk of fire, even in the case of overheating. This requirement shall be deemed to be met if the installation ensures an adequate distance to all parts and suitable ventilation, by the use of fire resistant materials or by the use of heat shields.*

5.3.2.3 *In the case of M2 and M3 vehicles, the combustion heater must not be positioned in the passenger compartment. However, an installation in an effectively sealed envelope which also complies with the conditions in paragraph 5.3.2.2 may be used.*

5.3.2.4 *The label referred to in Annex 7, paragraph 4, or a duplicate, must be positioned so that it can be easily read when the combustion heater is installed in the vehicle.*

5.3.2.5 Every reasonable precaution should be taken in positioning the heater to minimize the risk of injury and damage to personal property.

### **5.3.3 Fuel supply**

5.3.3.1 The fuel filler must not be situated in the passenger compartment and must be provided with an effective cap to prevent fuel spillage.

5.3.3.2 In the case of liquid fuel heaters, where a supply separate from that of the vehicle is provided, the type of fuel and its filler point must be clearly labelled.

5.3.3.3 A notice, indicating that the heater must be shut down before refuelling, must be affixed to the fuelling point. In addition a suitable instruction must be included in the manufacturer's operating manual.

### **5.3.4 Exhaust system**

5.3.4.1 The exhaust outlet must be located so as to prevent emissions from entering the vehicle through ventilators, heated air inlets or opening windows.

### **5.3.5 Combustion air inlet**

5.3.5.1 The air for the combustion chamber of the heater must not be drawn from the passenger compartment of the vehicle.

5.3.5.2 The air inlet must be so positioned or guarded that blocking by rubbish or luggage is unlikely.

### **5.3.6 Heating air inlet**

5.3.6.1 The heating air supply may be fresh or re-circulated air and must be drawn from a clean area not likely to be contaminated by exhaust fumes emitted either by the propulsion engine, the combustion heater or any other vehicle source.

5.3.6.2 The inlet duct must be protected by mesh or other suitable means.

### **5.3.7 Heating air outlet**

5.3.7.1 Any ducting used to route the hot air through the vehicle must be so positioned or protected that no injury or damage could be caused if it were to be touched.

5.3.7.2 The air outlet must be so positioned or guarded that blocking by rubbish or luggage is unlikely.

### **5.3.8 Automatic control of the heating system**

5.3.8.1 The heating system must be switched off automatically and the supply of fuel must be stopped within five seconds when the vehicle's engine stops running. If a manual device is already activated, the heating system can stay in operation.

## **ANNEX 7**

### **ADDITIONAL REQUIREMENTS FOR COMBUSTION HEATERS**

#### **7 Warning light**

7.1 A clearly visible tell-tale in the operator's field of view shall inform when the combustion heater is switched on or off.

End of extract.

## 2 Use / version

### 2.1. Use of the water heaters

Webasto DBW 2010 / 2016 water heaters are used in connection with the vehicle's own heating system

- to heat the passenger cabin,
- to defrost the vehicle windows and
- to preheat water-cooled engines.

The water heater operates independently of the engine and is connected to the cooling system, the fuel system and the electrical system of the vehicle.

The heater is approved for heating the passenger cabin or the driver's cab, but not to heat a cargo space used to transport hazardous substances.

### 2.2. Version

The water heaters are approved for use with "diesel" fuel (DIN EN 590) .

The heat output is:

- |                   |                         |
|-------------------|-------------------------|
| – DBW 2010 heater | 11.6 kW (10,000 kcal/h) |
| – DBW 2016 heater | 16.0 kW (13,800 kcal/h) |

The heaters DBW 2010 are designed for 12 or 24 V.

The heaters DBW 2016 only for 24 V.

Depending on requirements and equipment, a nozzle block preheating system may be fitted.

### 3 Installation

**IMPORTANT:**

The statutory regulations governing installation (See Chapter 1, "Statutory regulations governing installation") must be adhered to.

**NOTE:**

Check the installation situation of the relevant vehicle type.

#### 3.1. Installation position

The heater and circulating pump are to be integrated into the cooling system (or in a separate heating system).

The heater must be installed in as low a position as possible to allow the heater and circulating pump to be bled automatically. This is particularly important as the circulating pump is not self-priming.

The heater must not be installed in the vehicle interior.

If it is not possible to install the heater in the vehicle's engine bay it may be installed in a box. The installation box must have sufficient external ventilation to ensure that a maximum temperature of 85 °C (storage temperature, 60 °C in operation) is not exceeded in the box.

Bear in mind the space required for servicing accessibility (for example for removing the combustion chamber) (see Figure 1) when installing the heater.

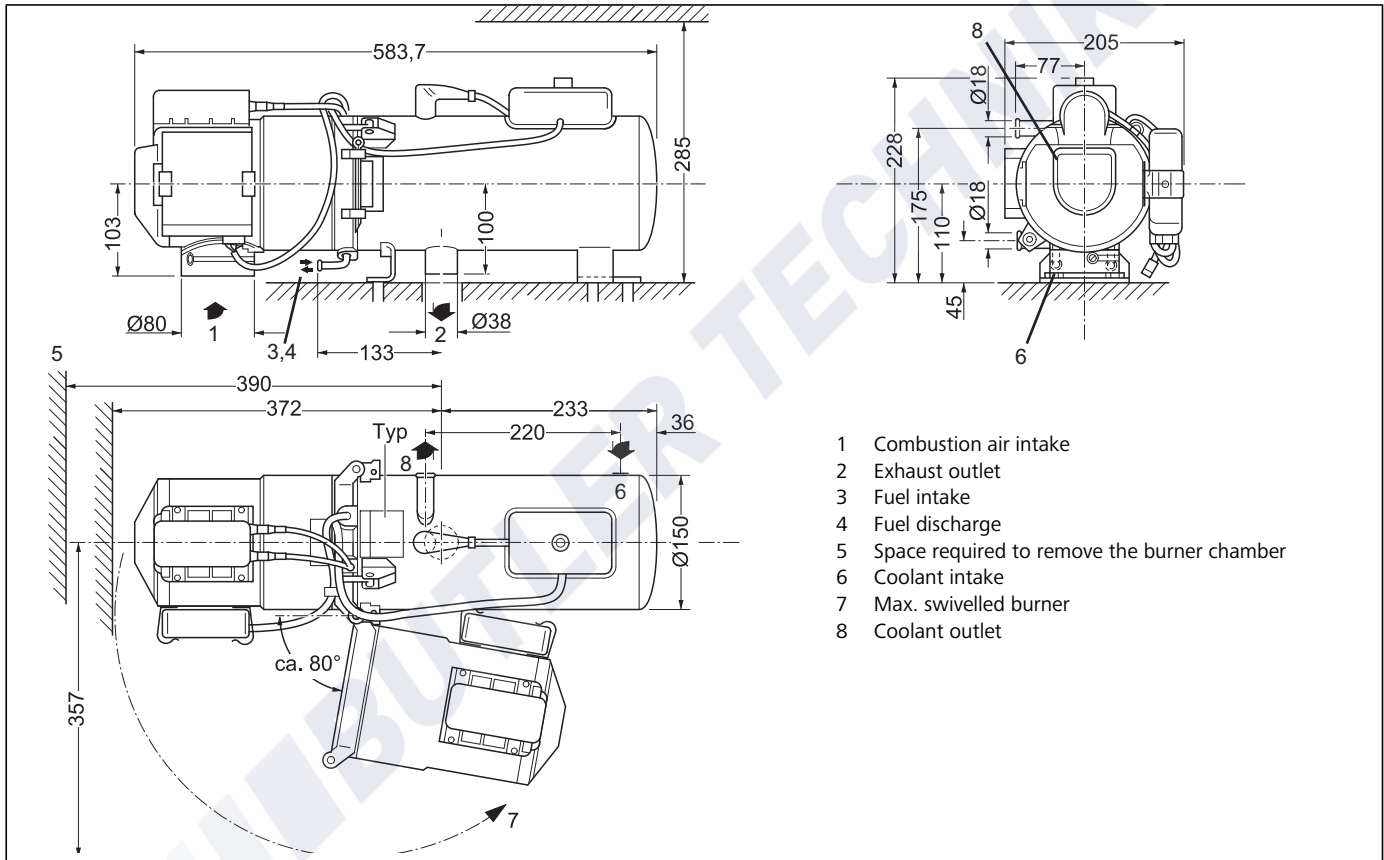

- 1 Combustion air intake
- 2 Exhaust outlet
- 3 Fuel intake
- 4 Fuel discharge
- 5 Space required to remove the burner chamber
- 6 Coolant intake
- 7 Max. swivelled burner
- 8 Coolant outlet

Fig. 1: Dimensions of DBW 2010 / 2016 heaters

# Installation

### 3.2. To install DBW 2010 / 2016 heaters

The heater may be secured either with four M8 screws or with four bolts and nuts (see Figure 3).

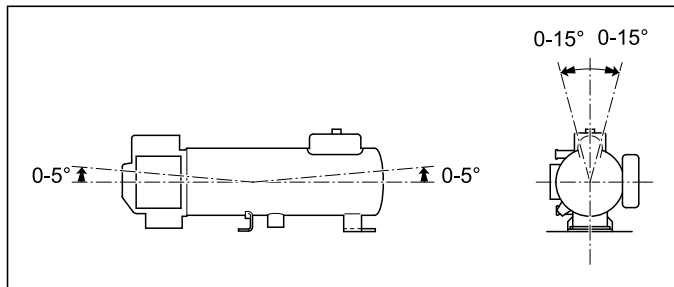

Fig. 2: Position

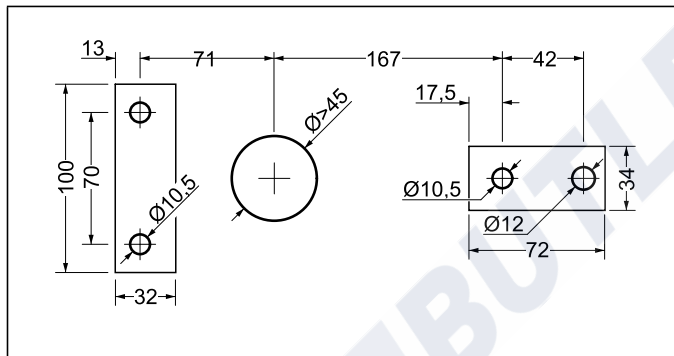

Fig. 3: Hole pattern

### 3.3. Model plate

The model plate must be protected from damage and must be clearly legible when the heater is installed (otherwise a duplicate model plate must be used).

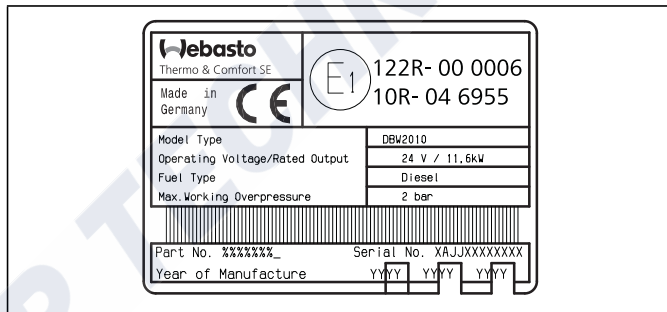

Fig. 4: DBW 2010 model plate (DBW 2016 similar)



#### 4 Installation example for DBW 2010 / 2016

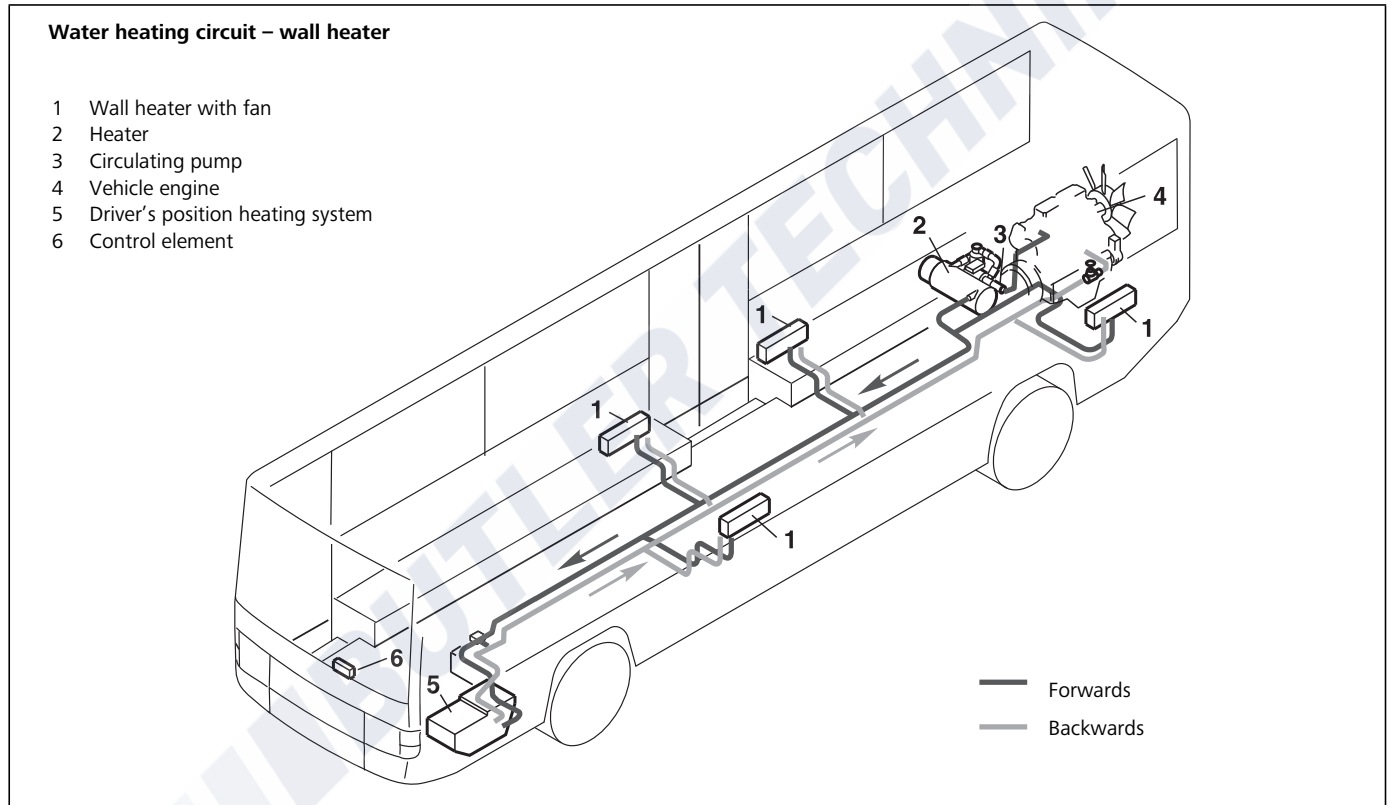

Fig. 5: Installation example for DBW 2010 / 2016 heaters

## To install the circulating pump

### 5 To install the circulating pump

The circulating pump is installed as shown in Figure 7 (U 4840). Note the installation position.

**NOTE:**

The pump ports and connection lines from the water intake and water outlet must be flush (no stress).

#### 5.1. U 4840 circulating pump

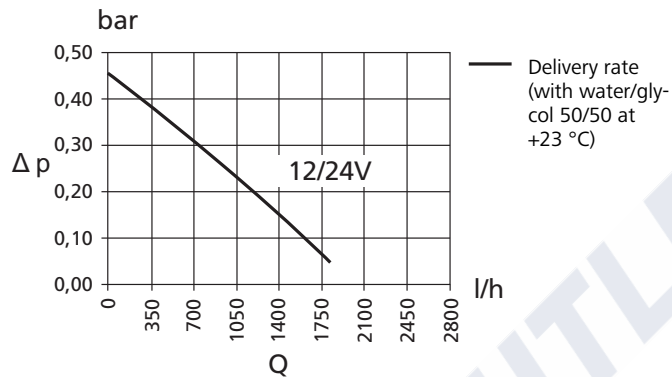

Fig. 6: Delivery rate U 4840 circulating pump

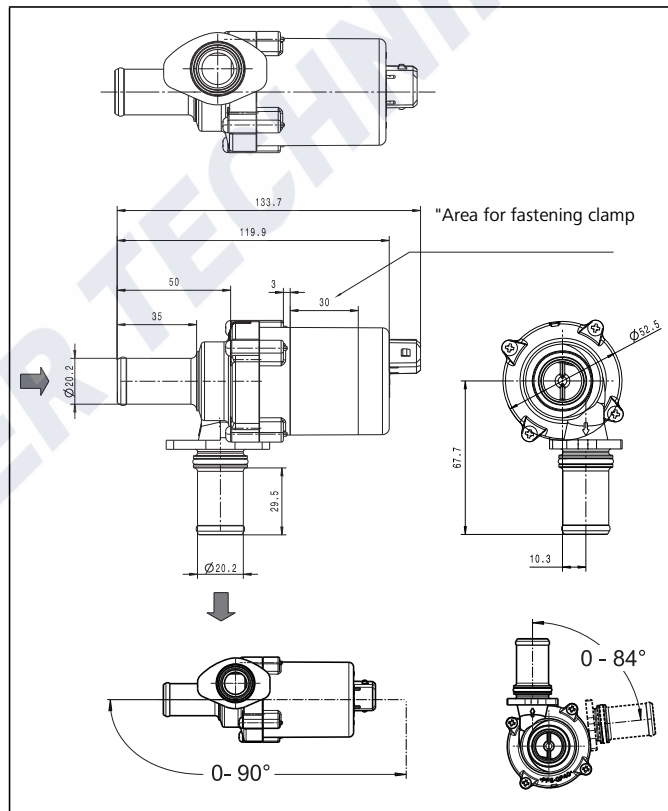

Fig. 7: U 4840 circulating pump installation position

## 6 Connection to the vehicle cooling system

The heater is connected to the vehicle cooling system as shown in Figures 1 and 5. The system must contain at least 10 litres of coolant.

The water hoses supplied by Webasto must always be used. If you do not use these hoses, the hoses that you do use must comply with DIN 73411. The hoses must be installed without kinks and (to ensure perfect bleeding of the heater) rising if possible. Hose connections must be supported by hose clips to prevent them slipping.

### **NOTE:**

The hose clips must be tightened with a torque of 1.5 Nm.

Only pressure valves with an opening pressure of min. 0.4 bar and max. 2.0 bar may be used in the vehicle's cooling system or in a separate heating system.

The cooling system must be bled carefully before using the heater for the first time or after replacing the coolant. The heater and lines should be installed in such a way as to ensure static bleeding.

Perfect ventilation can be identified by the circulating pump operating almost silently. Poor bleeding may cause the resetting temperature limiter to trip whilst the heater is operating.

## Fuel supply

### 7 Fuel supply

The fuel is taken from the vehicle fuel tank or from a separate fuel tank.

#### 7.1. Fuel lines

Fuel lines are to be installed with a gradient wherever possible to prevent air inclusions. Connections within the line are to be secured with hose clips if no mechanical screw connectors are used.

If fuel hoses are used, the hoses supplied by or available from Webasto must generally be used. If you do not use these hoses, the fuel hoses that you do use must comply with DIN 73379. Fuel hoses must not be kinked or twisted and must be secured with clips approx. every 25 cm.

Only the normal steel, copper and plastic lines of plasticised, light and temperature-stabilized PA 11 or PA 12 (e.g. Mecanyl RWTL) pursuant to DIN 73378 used in the manufacture of motor vehicles may be used for the fuel lines, together with the appropriate connectors.

The following must be observed for the installation of fuel lines:

- The lines must be protected from the effects of high temperatures.

#### **IMPORTANT!**

**The external casing on the heater may reach the ignition temperature of diesel if it is operated without coolant.**

- **The lines must be protected from stone damage.**
- **Dripping or evaporating fuel must not be allowed either to accumulate or to ignition hot parts or electrical equipment**

If a shut-off device is installed in the return line, an information sticker as shown in Figure 8 is to be affixed where it is clearly visible.

#### **IMPORTANT:**

Operation with a closed return line will damage the fuel pump.  
Fuel may escape. Danger of fire!

Unsupported fuel lines must be secured to prevent them sagging.

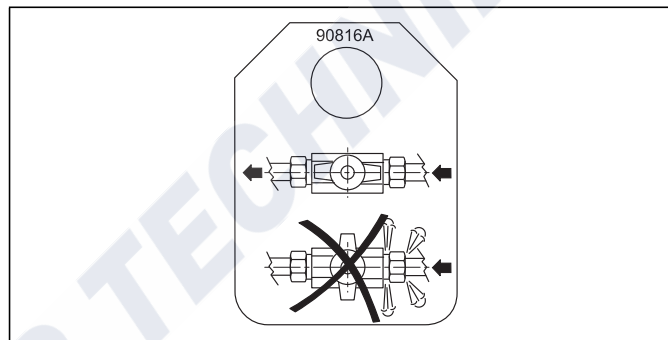

**Fig. 8: Information sticker**

Do not install an additional fuel pump.

See Chapter 1, "Statutory regulations governing installation" for the statutory regulations.

**7.1.1. Maximum dimensions of the fuel lines:**

- Internal diameter for intake and return line: 6 mm (other diameters to order).
- Maximum line length for each intake and return line: 10 m
- Maximum intake height: 2 m (the installation of a check valve is recommended for the maximum intake height)
- Maximum supply pressure: 0.3 bar.

**7.2. Fuel filter**

A fuel filter supplied or approved by Webasto must be used (check the flow direction). To avoid malfunctions the filter or filter insert is to be replaced before the start of the cold weather.

## Combustion air supply

### 8 Combustion air supply

Under no circumstances may the combustion air be taken from areas occupied by people. The combustion air intake opening must not point in the direction of travel. It must be located so that it cannot become clogged with dirt or snow and cannot suck in splashing water.

Maximum dimensions of the fuel intake line:

- Internal diameter: 55 mm
- Maximum line length: 5 m without the exhaust extension
- Maximum bends: 270 °

The combustion air intake must not be routed above the exhaust outlet.

**NOTE:**

If the combustion air intake line cannot be installed so that it slopes downwards, a water drain hole with a diameter of 4 mm is to be made at its lowest point.

If the heater is installed in a general installation space near the vehicle's fuel tank, the combustion air must be taken in from the outside and the exhaust fumes discharged into the atmosphere. The openings must be splash-proof.

A ventilation opening measuring at least 20 cm<sup>2</sup> is required if the heater is installed in an enclosed box.

The size of the ventilation opening must be increased subject to consultation with Webasto if the temperature in the box exceeds the permitted ambient temperature of the heater (see Technical data).

## 9 Exhaust pipe

The opening of the exhaust pipe must not point towards the front of the vehicle.

The exhaust pipe opening must be located so that it cannot become clogged with snow and mud.

Rigid pipes of unalloyed or alloyed steel with a minimum wall thickness of 1.0 mm or flexible piping of alloyed steel only must be used as the exhaust line. The exhaust pipe is secured to the heater using a clamping collar, for example. See the statutory regulations for other requirements.

Maximum dimensions of the exhaust pipe:

- Internal diameter: 38 mm
- Maximum line length: 5 m without the combustion air intake extension
- Maximum bend: 270 °

**NOTE:**

If the exhaust line is installed near heat-sensitive parts, it must be insulated.

## 10 Electrical connections

### 10.1. Heater connection

#### IMPORTANT HIGH VOLTAGE:

Danger of death. Disconnect the plug connection to the vehicle before you open the heater.

The electrical connection of the heaters is made as shown in Figure 9 (DBW 2010), Figure 10 (DBW 2010) or Figure 11 (DBW 2016 Rail):

System circuit for DBW 2010 / 2016 with SG 1553 control unit and switch.

Connections of the heaters differing from those of the standard variant (Figures 9 / 10) are shown in Figure 11 (DBW 2016 Rail), Figure 12 (heater variants and plug assignments), Figures 13 / 14 (nozzle block preheating system).

Use the specified cable cross-sections.

Connect the negative and positive terminals of the heater controller directly to the battery.

### 10.2. Connecting the controls

The heater can be switched on and off using the following Webasto controls:

- Switch, see automatic circuit diagram figures 9 to 14

### 10.3. Legend circuit diagrams

Cable cross-sections		
	< 7.5 m	7.5 m–15 m
—	0.75 mm <sup>2</sup>	1.0 mm <sup>2</sup>
- - -	0.75 mm <sup>2</sup>	1.0 mm <sup>2</sup>
- - - -	1.0 mm <sup>2</sup>	1.5 mm <sup>2</sup>
— — —	1.5 mm <sup>2</sup>	2.5 mm <sup>2</sup>
— — — —	2.5 mm <sup>2</sup>	4.0 mm <sup>2</sup>
— — — — —	4.0 mm <sup>2</sup>	6.0 mm <sup>2</sup>
- - - - -	Vehicle's own cable	

Cable colours	
bl	blue
br	brown
ge	yellow
gn	green
gr	grey
or	orange
rt	red
sw	black
vi	violet
ws	white



Item	Designation	Comment	A	B	C	D
A1	Heater			●		
A2	Control unit	SG 1553	●			
4	Ignition spark generator		●			
5	Thermostat	Control thermostat (internal)	●			
7	Thermostat	Fan thermostat	○	○	○	
8	Thermostat	Temperature limiter thermostat	●			
10	Ignition electrodes		●			
61.3	Interferencesuppression set (2x)	Radio interference suppression			○	
A	Plug connection	Control unit, 2-pin	●			
B	Plug connection	Control unit, 6-pin	●			
B5	Thermostat	Nozzle block preheating	○			
C	Plug connection	Control unit, 8-pin	●			
F1	Temperature fuse	Any polarity	●			
F2	Fuse 20 A	Blade-type fuse SAE J 1284		○		
F3	Fuse 10 A	Blade-type fuse SAE J 1284		○		
F4	Fuse 20 A	Blade-type fuse SAE J 1284		○		
F5	Fuse	Blade-type fuse DIN 72581				●
F6	Fuse	Blade-type fuse DIN 72581		○		
H1	Light, green	Indicator		●		
H2	Light, circulating pump	if controlled via S4			○	
K1	Relay	Circulating pump; negative for heater				
K2	Relay	Heater motor				
K3	Relay	Light, control thermostat operation				
K4	Relay	Ignition spark generator				
K5	Relay	Solenoid valve, flame monitor				
K6	Relay	Nozzle block preheating	○			
K7	Relay	Vehicle heating fan			○	
M1	Motor	Circulating pump		●		
M2	Motor	Combustion air fan	●			

Item	Designation	Comment	A	B	C	D
M3	Motor	Vehicle fan				●
R	Flame monitor	Photoresistor, any polarity	●			
R1	Motor resistor	Power resistor	○			
R2	Resistor, heating cartridge	Nozzle block preheating	●			
S1	Switch	Heater on/off		●		
S3	Switch on water tap	Contact open when water tap closed			○	
S4	Switch	for on/off, circulating pump separate			○	
S6	Switch	Vehicle fan				●
SD	Protective diode	Diode 5KP36A	○			
X1	Plug connector, 2-pin			○		
X2	Plug connector, 1-pin			○		
X3	Plug connector, 2-pin			○		
X5	Plug connector, 4-pin			○		
Y1	Solenoid valve	Any polarity	●			
A	Fitted in heater					
B	Parts supplied loose					
C	Only if required					
D	In vehicle					
●	Set assignment					
○	Possible depending on scope of supply or version					

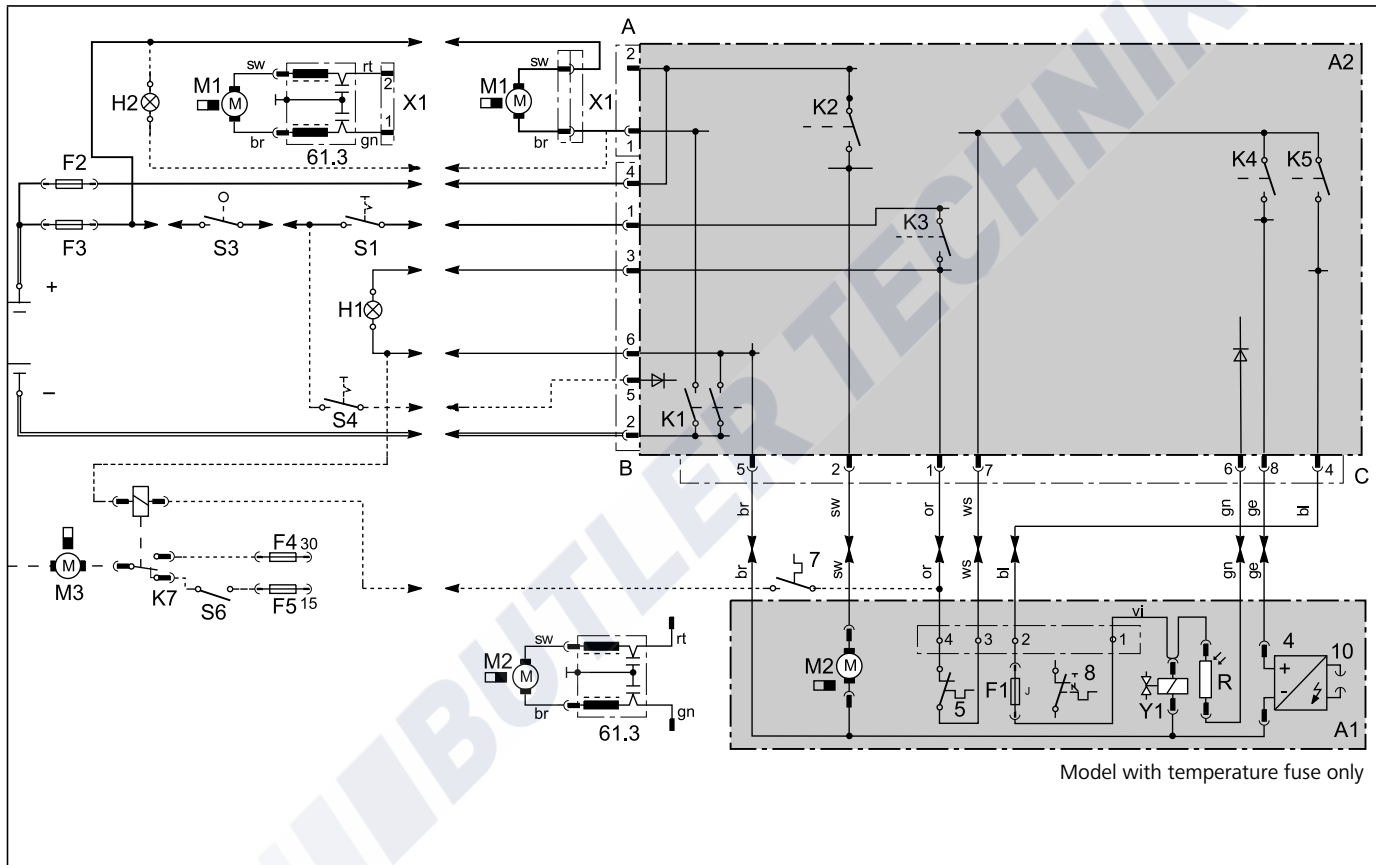

Fig. 9: System circuit for DBW 2010 with control unit 1553 and switch, see legend on page 40 and 41

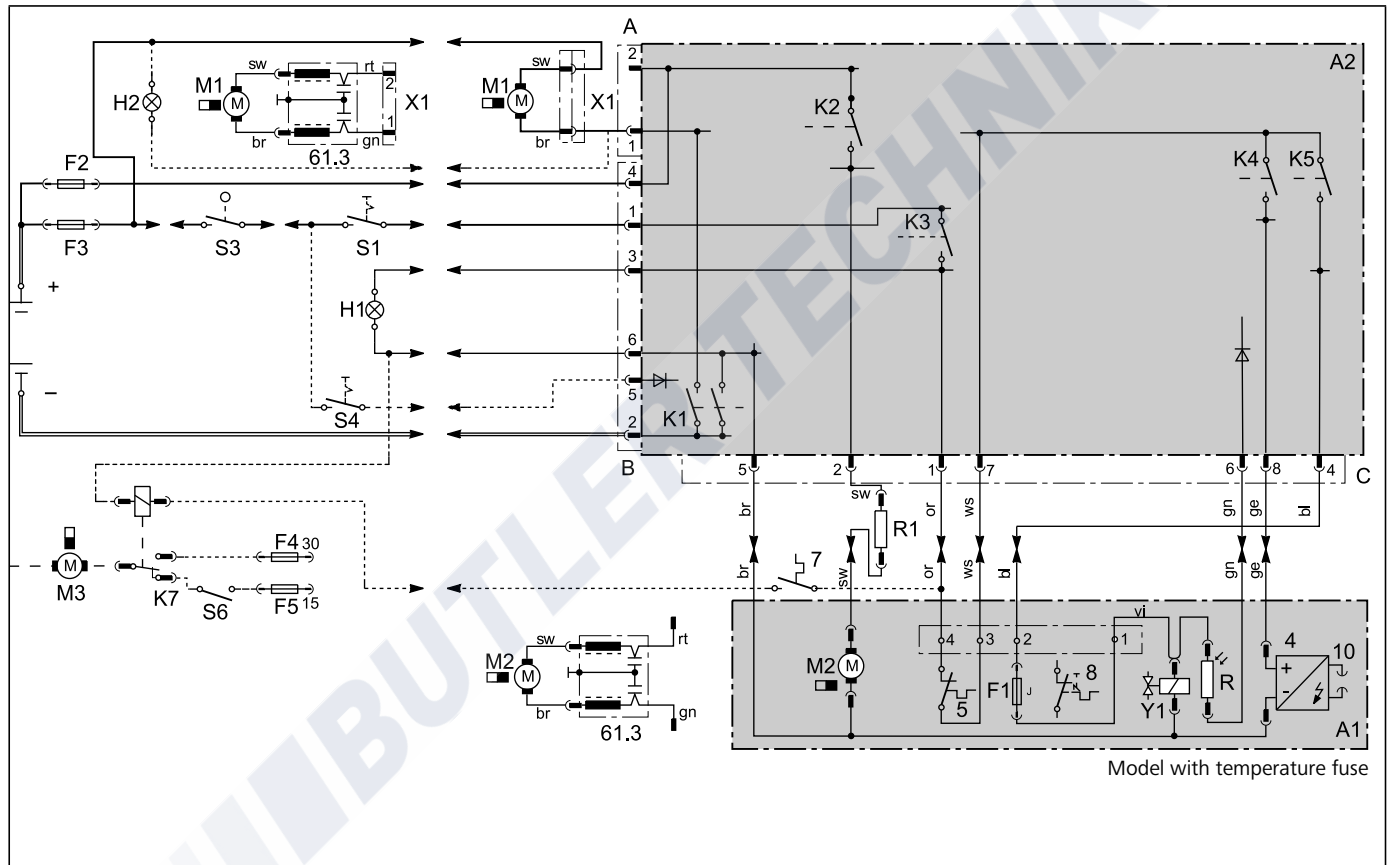

Fig. 10: System circuit for DBW 2016 with control unit 1553 and switch, see legend on page 40 and 41

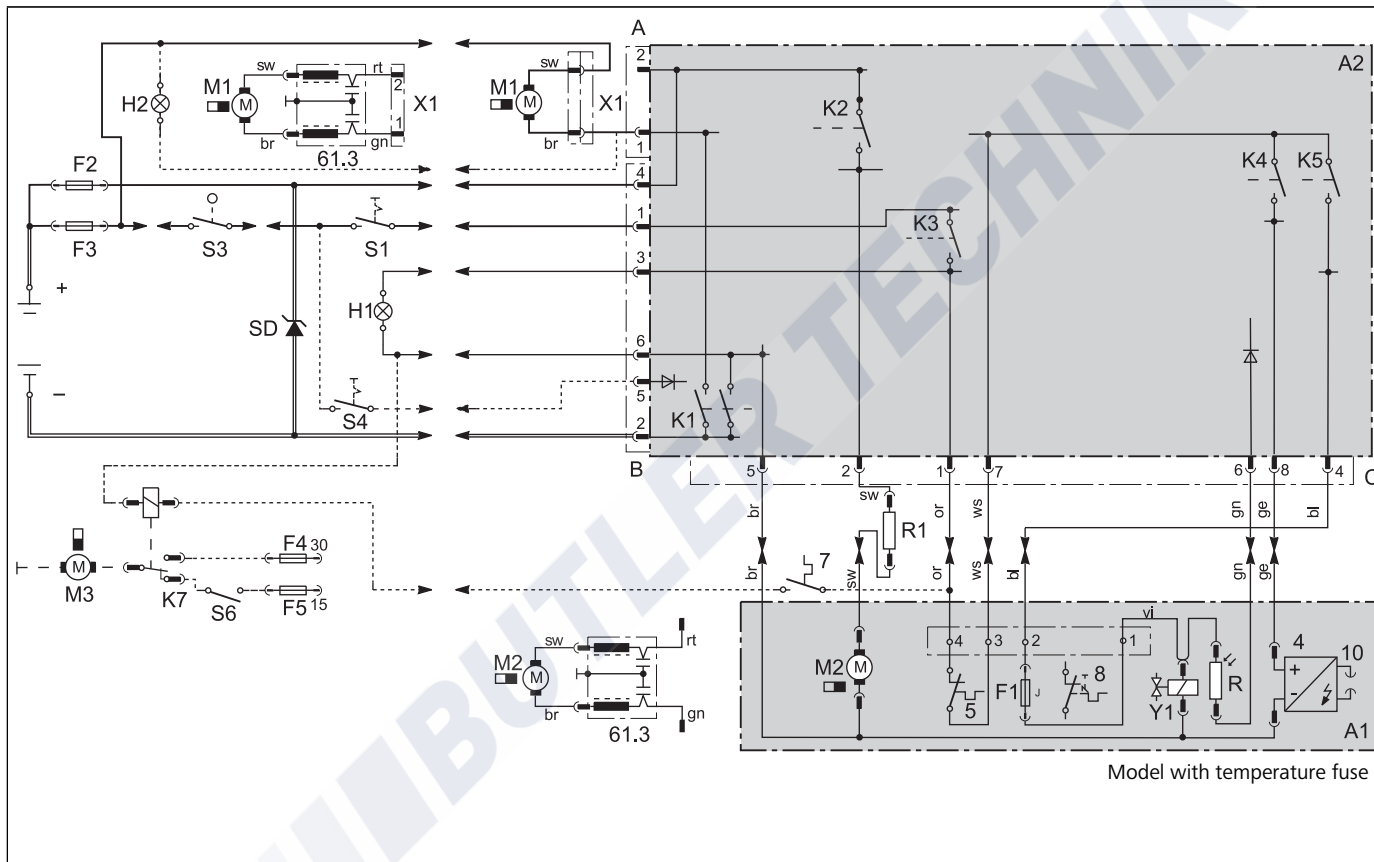

Fig. 11: System circuit for DBW 2016 Rail with control unit 1553 and switch, see legend on page 40 and 41

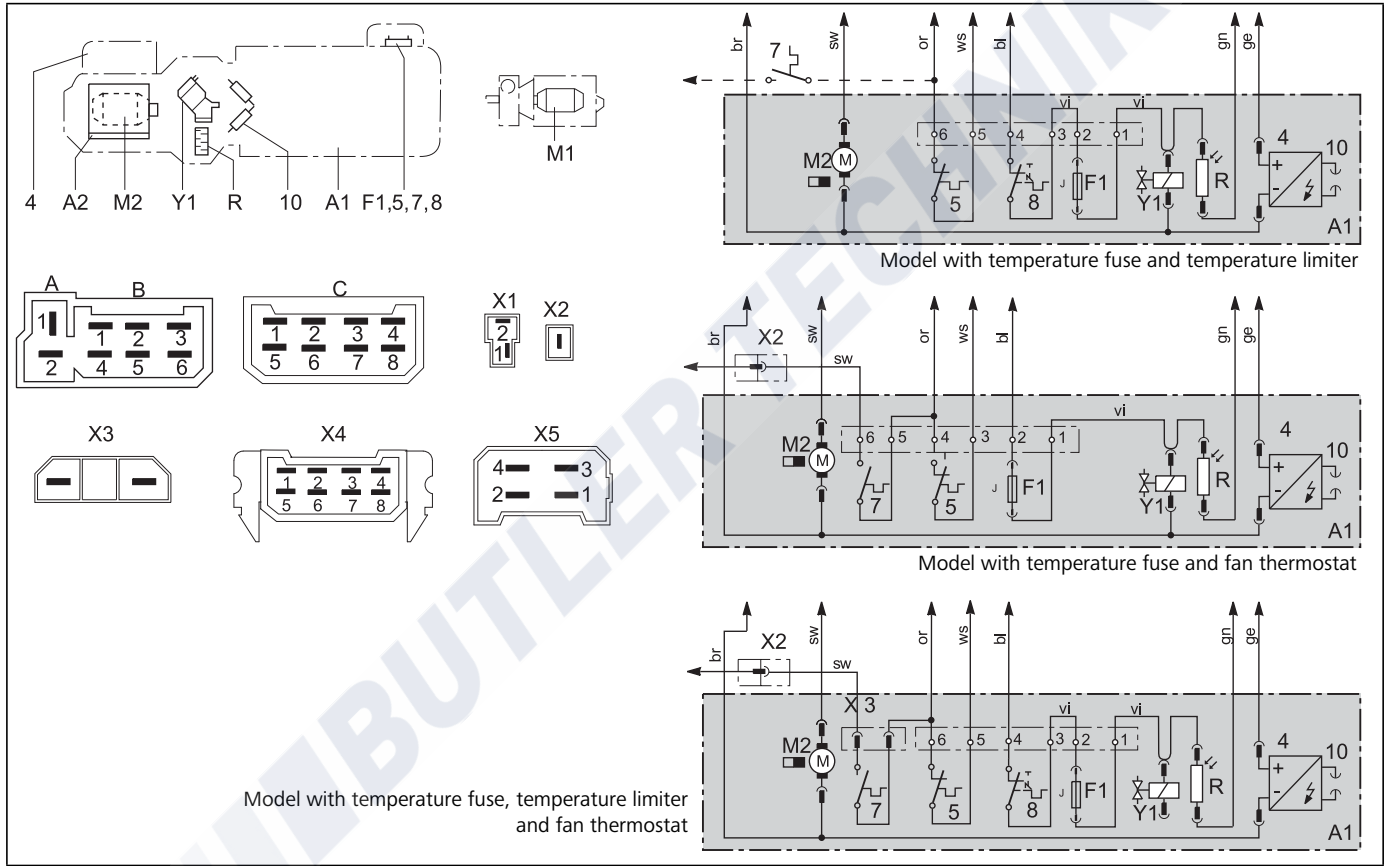

Fig. 12: Unit variants and plug assignments, see legend on page 40 and 41



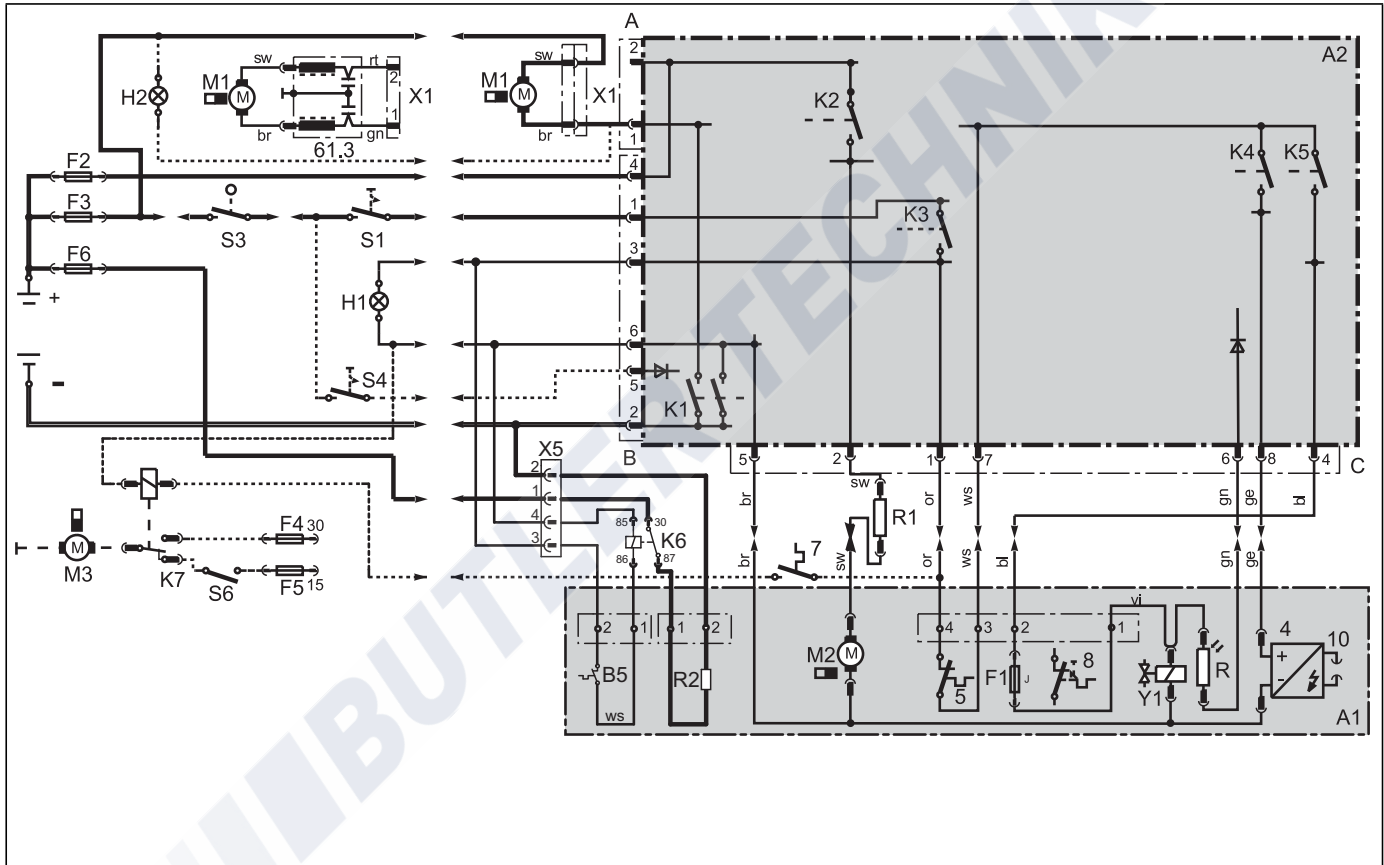

Fig. 14: System circuit for DBW 2016 with control unit 1553, switch and nozzle block preheating system, see legend on page 40 and 41

## Initial start-up

---

### 11 Initial start-up

**NOTE:**

Refer to the safety instructions in the operating and maintenance instructions.

The operating and maintenance instructions must be read through without fail before starting the heater.

After you have installed the heater, bleed the water system and the fuel supply system carefully. Follow the instructions supplied by the vehicle manufacturer for this purpose.

Conduct a trial of the heater to check all the water and fuel connections for leaks and to ensure that they are secure. If the heater suffers a fault during operation, the fault must be located and remedied.



## 12 Troubleshooting

### 12.1. Fault lock-out

If it recognises one of the following fault features, the heater will conduct a fault lock-out.

- If there is undervoltage, approx. 10 – 25 seconds after the voltage drops below the switching threshold.
- If no combustion starts within approx. 30 seconds after the heater is switched on
- If the fuel supply is interrupted for more than 10 seconds during heating operation
- If the heater is switched off by the temperature fuse or the temperature limiter due to overheating. In such a case, the temperature fuse must be replaced with another of the same type (note the colour code) or the button on the temperature limiter must be reset (after cooling to below 60 °C).

### 13 Technical data

Except where limit values are specified, these technical data refer to the usual heater tolerances of  $\pm 10\%$  at an ambient temperature of  $+20\text{ °C}$  and at the rated voltage.

#### 13.1. Fuel

Diesel fuel in accordance with DIN EN 590 is suitable as fuel.

We know of no negative influences due to additives.

If fuel is extracted from the vehicle's tank, follow the additive instructions issued by the vehicle manufacturer.

If fuel is extracted from a separate fuel tank, a winter diesel fuel must be used in temperatures below  $0\text{ °C}$ . Media to improve the flow properties of the fuel may also be used.

If you change to low-temperature fuel, the heater must be operated for approx. 15 minutes so that the fuel line, filter and fuel pump are filled with the new fuel.

Heater		DBW 2010	DBW 2016
ECE type permit number			
EMC:		E1 10R- 04 6955	E1 10R- 04 6955
Heating system:		E1 122R- 00 0006	E1 122R- 00 0001
Model		High pressure atomiser	High pressure atomiser
Heating current		11.6	16.0
		(kcal/h)	(13,800)
Fuel		Diesel (DIN EN 590)	Diesel (DIN EN 590)
Fuel consumption		1.3	1.9
Rated voltage		12 or 24	24
Operating voltage range		10...14 or 20...28	22...28
Rated power consumption (without circulating pump)		60	90
Max. ambient temperature during operation (Heater, control unit, circulating pump)		-40... +60	-40... +60
Max. storage temperature (Heater, control unit, circulating pump)		-40 ... +85	-40 ... +85
Max. operating pressure		0.4...2.0	0.4...2.0
Capacity of the heat exchanger		1.1	1.1
Minimum capacity of the system		10.00 l	10.00 l
CO <sub>2</sub> in exhaust gas at rated voltage		10.5 ±0.5	10.5 ±0.5
Heater dimensions		Length 584	Length 584
(Tolerance ±3 mm)		Width 205	Width 205
		Height 228	Height 228
Weight		14.5	14.5

<b>Circulating pump</b>		<b>U 4840</b>
Delivery rate	l/h	1600 (against 0,1 bar)
Rated voltage	V-	12 or 24
Operating voltage range	V -	9...15 or 16...30
Rated power consumption	W	30
Dimensions	mm	Length 135
(Tolerance $\pm 3$ mm)	mm	Width 95
	mm	Height 48
Weight	kg	0,4

/// BUTLER TECHNIK

Im Fall einer mehrsprachigen Version ist Deutsch verbindlich.

Die Telefonnummer des jeweiligen Landes entnehmen Sie bitte dem Webasto Servicestellenfaltblatt oder der Webseite Ihrer jeweiligen Webasto Landesvertretung.

In multilingual versions the German language is binding.

The telephone number of each country can be found in the Webasto service center leaflet or the website of the respective Webasto representative of your country.

Dans le cas d'une version rédigée en plusieurs langues, l'allemand est alors la langue qui fait foi.

Pour trouver le numéro de téléphone du pays concerné, veuillez consulter le dépliant des points-service Webasto ou la page web de la représentation Webasto de votre pays.

Webasto Thermo & Comfort SE

Postfach 1410

82199 Gilching

Germany

Visiting address:

Friedrichshafener Str. 9

82205 Gilching

Germany

Technical Extranet: <http://dealers.webasto.com>

Only within Germany

Tel.: 0395 5592 444

E-mail: [technikcenter@webasto.com](mailto:technikcenter@webasto.com)

[www.webasto.com](http://www.webasto.com)