



# Air Heater V 7 S

**Technical description**  
**Installation instructions**  
**Operating instructions**  
**Maintenance instructions**

**Eberspächer**

EN

**UNCONTROLLED  
COPY**

J. Eberspächer  
GmbH & Co. KG  
Eberspächerstr. 24  
D - 73730 Esslingen

Telefon (zentral)  
(07 11) 9 39 - 00  
Telefax  
(07 11) 9 39 - 05 00

[www.eberspaecher.com](http://www.eberspaecher.com)

## **Engine-independent air heater V 7 S for diesel fuel**

Heater

Order no.

V 7 S – 24 volt

25 1728 00 00 00



**Please give this manual to the customer  
after installation of the heater.**

# 1 Introduction

## Contents

Chapter	Title	Contents	Page
1	<b>Introduction</b>	<ul style="list-style-type: none"> <li>• Concept of this manual ..... 3</li> <li>• Special text structure, presentation and picture symbols ..... 4</li> <li>• Important information before starting work ..... 4</li> <li>• Statutory regulations ..... 5, 6</li> <li>• Safety instructions for installation and operation ..... 6, 7</li> <li>• Accident prevention ..... 7</li> </ul>	
2	<b>Product information</b>	<ul style="list-style-type: none"> <li>• Scope of supply ..... 8, 9</li> <li>• Technical data ..... 10</li> <li>• Main dimensions ..... 11</li> </ul>	
3	<b>Installation</b>	<ul style="list-style-type: none"> <li>• Installation and location ..... 12</li> <li>• Installation location ..... 12, 13</li> <li>• Possible installation positions ..... 14</li> <li>• Mounting and fastening ..... 14</li> <li>• Nameplate ..... 15</li> <li>• Heater air system ..... 16</li> <li>• Exhaust system ..... 17</li> <li>• Combustion air system ..... 18</li> <li>• Fuel supply ..... 19 – 23</li> </ul>	
4	<b>Operation and function</b>	<ul style="list-style-type: none"> <li>• Operating instructions/ important information for operation ..... 24</li> <li>• Initial commissioning ..... 24</li> <li>• Description of functions ..... 25</li> <li>• Control and safety devices / EMERGENCY OFF ..... 26</li> </ul>	
5	<b>Electrical system</b>	<ul style="list-style-type: none"> <li>• Heater wiring ..... 27</li> <li>• Circuit diagram ..... 28</li> <li>• Parts list for the circuit diagram ..... 29</li> </ul>	
6	<b>Troubleshooting Maintenance Service</b>	<ul style="list-style-type: none"> <li>• If any faults occur, please check the following items ..... 30</li> <li>• Troubleshooting ..... 30</li> <li>• Maintenance instructions ..... 30</li> <li>• Service ..... 30</li> </ul>	
7	<b>Environment</b>	<ul style="list-style-type: none"> <li>• Certification ..... 31</li> <li>• Disposal ..... 31</li> <li>• EU Declaration of Conformity ..... 31</li> </ul>	
8	<b>Lists</b>	<ul style="list-style-type: none"> <li>• List of key words ..... 32, 33</li> <li>• List of abbreviations ..... 33</li> </ul>	



# 1 Introduction

## Concept of this manual

This manual aims to support the service company installing the heater and to provide the user with all important information about the heater.

The manual has been divided into 8 chapters to make it easier to find the corresponding information quickly.

### 1 Introduction

Here you will find important introductory information about installation of the heater and about the structure of the manual.

### 2 Product information

Here you will find information about the scope of supply, the technical data and the dimensions of the heater.

### 3 Installation

Here you will find important information and instructions referring to installation of the heater.

### 4 Operation and function

Here you will find information about the operation and function of the heater.

### 5 Electric system

Here you will find information about the electronic system and electronic components of the heater.

### 6 Troubleshooting / maintenance / service

Here you will find information about possible faults, troubleshooting, service / maintenance and the service hotline.

### 7 Environment

Here you will find information about certification and disposal of the heater together with the EU Declaration of Conformity.

### 8 Lists

Here you will find the key word list and abbreviations list.

# 1 Introduction

## Special text structure, presentation and picture symbols

This manual uses special text structures and picture symbols to emphasise different contents. Please refer to the examples below for the corresponding meanings and associated actions.

### Special structure and presentations

A dot (•) indicates a list which is started by a heading. If an indented dash (-) follows a dot, this list is subordinate to the dot.

### Picture symbols



#### Regulation!

This picture symbol with the remark "Regulation" refers to a statutory regulation. Failure to comply with this regulation results in expiry of the type permit for the heater and preclusion of any guarantee and liability claims on J. Eberspächer GmbH & Co. KG.



#### Danger!

This picture symbol with the remark "Danger!" refers to the risk of a fatal danger to life and limb. Failure to comply with these instructions can result in severe injuries under certain circumstances.



#### Caution!

This picture symbol with the remark "Caution!" refers to a dangerous situation for a person and / or the product. Failure to comply with these instructions can result in injuries to people and/or damage to machinery.

#### Please note!

These remarks contain application recommendations and useful tips for installation of the heater.

## Important information before starting work

### Range of application of the heater

The air heater operating independently of an engine is intended for installation in the following vehicles, depending on its heating output:

- Buses and coaches
- Truck cargo compartments
- Boats, ships and yachts

#### Please note!

- The heater is **not** certified for installation in vehicle compartments used by passengers (more than 8 seats). Exception see page 5: statutory regulations, arrangement of the heater.
- The heater is **not** allowed to be installed in vehicles used for the transport of dangerous goods as per ADR / ADR99.

### Purpose of the heater

- Pre-heating, de-misting windows
- Heating and keeping the following warm:
  - Driver and working cabs
  - Freight compartments
  - Ship's cabins
  - Passenger and crew compartments

On account of its functional purpose, the heater is **not** permitted for the following applications:

- Long-term continuous operation, e.g. for preheating and heating of:
  - Residential rooms
  - Garages
  - Work huts, weekend homes and hunting huts
  - Houseboats, etc.
- Heating or drying
  - Living creatures (people or animals) by blowing hot air directly at the subject
  - Objects
  - Blowing hot air into containers



#### Caution!

### Safety instructions for application and proper purpose!

- The heater must only be used and operated for the range of application stated by the manufacturer in compliance with the "Operating instructions" included with every heater.



# 1 Introduction

## Statutory regulations

The Federal Road Transport Directorate has issued an "EC type approval" and an "EMC type approval" for the heater for installation in motor vehicles and with the following official type approval marks, noted on the heater name plate.

Air heater V 7 S      EC-[e]00 0063  
EMC-[e]03 5620



### Regulation!

#### Directive 2001 / 56 / EU of the European Parliament and the Council

##### • Arrangement of the heater

- Parts of the structure and other components near the heater must be protected from excess heat exposure and possible contamination from fuel or oil.
- The heater must not pose a fire hazard even when it overheats.  
This requirement is deemed to be fulfilled when adequate clearance to all parts is observed during installation, sufficient ventilation is provided and fire-proof materials or heat plates are used.
- The heater must not be mounted in the passenger compartment of vehicles in class M<sub>2</sub> and M<sub>3</sub>.  
But a heater in a hermetically sealed enclosure which otherwise complies with the conditions stated above may be used.
- The factory nameplate or duplicate must be affixed so that it can still be easily read when the heater is installed in the vehicle.
- All appropriate precautions must be taken when arranging the heater to minimise the risk of injuries to persons or damage to other property.

##### • Operating status display

- A clearly visible operating display in the user's field of vision must indicate when the heater is switched on and off.

##### • Fuel supply

- The fuel intake connection must not be located in the passenger compartment and must be sealed with a properly closing lid to prevent any fuel leaks.
- In heaters for liquid fuel where the heater fuel is separate from the vehicle fuel, the type of fuel and intake connection must be clearly identified.
- A warning sign is to be fixed to the intake connection indicating that the heater must be switched off before refuelling.

##### • Exhaust system

- The exhaust outlet must be arranged so as to prevent any penetration of exhaust fumes into the vehicle interior through the ventilation system, warm air intakes or open windows.

##### • Combustion air intake

- The air for the heater combustion chamber must not be sucked in from the passenger compartment of the vehicle.
- The air intake must be arranged or protected in such a way that it cannot be blocked by other objects.

##### • Heater air intake

- The heater air supply must consist of fresh air or circulated air and be sucked in from a clean area not contaminated by exhaust fumes of the drive machine, the combustion heater or any other source in the vehicle.
- The intake pipe must be protected by a grid or other suitable means.

# 1 Introduction

## Statutory regulations

### • Hot air outlet

- The hot air pipes within the vehicle must be arranged or protected in such a way that there is no risk of injury or damage if they are touched.
- The air outlet must be arranged or protected in such a way that it cannot be blocked by any objects.

### Please note!

- Compliance with the statutory regulations and safety instructions is prerequisite for guarantee and liability claims. Failure to comply with the statutory regulations and safety instructions and incorrect repairs even when using original spare parts make the guarantee null and void and preclude any liability for J. Eberspächer GmbH & Co. KG.
- Subsequent installation of this heater must comply with these installation instructions.
- The statutory regulations are binding and must also be observed in countries which do not have any special regulations.
- When the heater is to be installed in vehicles not subject to the German Ordinance for the Registration of Motor Vehicles (StVZO), for example ships, the specially valid regulations and installation instructions for these special applications must be observed.
- Installation of the heater in special vehicles must comply with the regulations applying to such vehicles.
- Other installation requirements are contained in the corresponding sections of this manual.

## Safety instructions for installation and operation



### Danger!

#### Risk of injury, fire and poisoning!

- The heater must only be started up when the maintenance flap is closed and the outlet hood is mounted in position.
- The maintenance flap must not be opened during operation.
- Disconnect the vehicle battery before commencing any kind of work.
- Before working on the heater, switch the heater off and let all hot parts cool down.
- The heater must not be operated in closed rooms, e.g. in the garage or in a multi-storey car park.
- Adjustable hot air outlets must always be adjusted so that they cannot blow hot air directly at living creatures (people, animals) or objects sensitive to temperature (loose and / or fastened).



### Caution!

#### Safety instructions for installation and operation!

- The year of initial commissioning must be marked on the nameplate.
- The heat exchanger of air heaters is a component subject to high thermal loads which must be replaced 10 years after initial commissioning of the heater. In addition, the installation date must be entered on the plate "original spare part" enclosed with the heat exchanger must. Then affix the plate next to the nameplate on the heater.
- The heater must only be installed by a JE partner authorised by the manufacturer according to the instructions in this manual and possibly according to special installation recommendations; the same applies to any repairs to be carried out in the case of repairs or guarantee claims.
- Only the control elements approved by Eberspächer must be used to operate the heater. The use of other control elements can cause malfunctions.



## 1 Introduction

### Safety instructions for installation and operation



#### Caution!

#### Safety instructions for installation and operation!

- Repairs by unauthorised third-parties or with not original spare parts are dangerous and therefore not allowed. They result in expiry of the type permit of the heater; consequently, when installed in motor vehicles they can cause expiry of the vehicle operating licence.
- The following measures are not allowed:
  - Changes to components relevant to the heater.
  - Use of third-party components not approved by Eberspächer.
  - Nonconformities in installation or operation from the statutory regulations, safety instructions or specifications relevant to safe operation as stated in the installation instructions and operating instructions. This applies in particular to the electrical wiring, fuel supply, combustion air system and exhaust system.
- Only original accessories and original spare parts must be used during installation or repairs.
- When carrying out electric welding on the vehicle, the plus pole cable at the battery should be disconnected and placed at ground to protect the controller.
- The heater must not be operated where there is a risk of an accumulation of flammable vapours or dust, for example close to
  - fuel depot
  - coal depot
  - wood depot
  - grain depots etc.
- The heater must be switched off when refuelling.
- When the heater is mounted in a safety housing etc., the installation compartment of the heater is not a stowage compartment and must be kept clear.  
In particular fuel canisters, oil cans, spray cans, gas cartridges, fire extinguishers, cleaning rags, items of clothing, paper etc. must not be stored or transported on or next to the heater.
- Defect fuses must only be replaced by fuses with the prescribed rating.
- If fuel leaks from the heater fuel system, arrange for the damage to be repaired immediately by a JE service partner.
- After-running of the heater must not be interrupted prematurely e.g. by pressing the battery disconnecting switch, apart from in the case of an emergency stop.

### Accident prevention

General accident prevention regulations and the corresponding workshop and operation safety instructions are to be observed.

## 2 Product information

### Scope of supply for air heater V 7 S

Quantity / Designation	Order No.
1 V 7 S heater – 24 volt	25 1728 00 00 00

### Scope of supply

1 V 7 S heater – 24 V preassembled, with basic fitout and controls	25 1728 05 00 00
--	------------------

### Parts list for the picture “Scope of supply” on page 9

Pict.-No.	Quantity / Designation	Order No.
Basic device – includes:		
1	1 Preassembled basic device	
2	1 Pipe socket	
3	1 Seal	
4	1 Fixing clip	
Basic fitout – includes:		
5	1 Control box with mounting bracket	
6	1 Metering pump with mounting bracket	
Controls – including:		
7	1 Amplifier	
8	1 Rotary rheostat	
9	1 Pin housing, complete	
10	1 Push-on sleeve housing	
11	1 Relay	
12	1 Socket, 5-pin	
13	1 “Heat – Off – Ventilate” switch	
14	1 Thermal fuse cut-out	
15	1 Control lamp	
16	1 Push-on sleeve housing, 4-pin	
17	1 Push-on sleeve housing, 3-pin	
Extra parts:		
18	1 Pipe clip	152 10 062
19	1 Flexible exhaust pipe	360 61 381
20	1 End sleeve	20 1000 40 02 00
21	1 Hose clip	10 2064 03 20 50
22	1 Combustion air intake pipe	10 2114 25 00 00
23	1 End sleeve	25 1480 89 04 00
24	1 End sleeve	25 1729 89 00 02

**Please note!**

- Parts without picture number are small parts and packed in a bag.
- Please consult the additional parts catalogue if any other parts are required for installation.





## 2 Product information

### Scope of supply

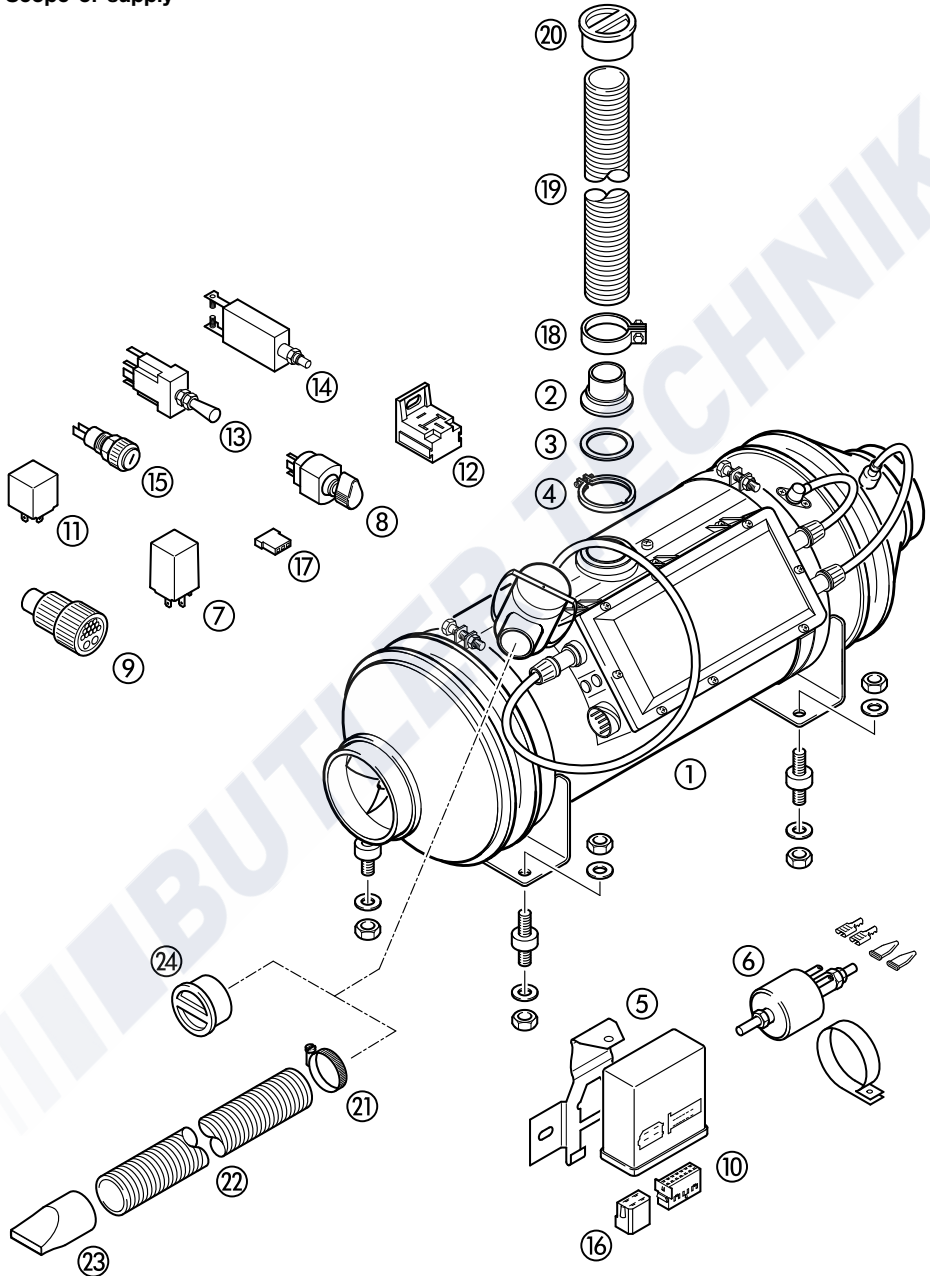

## 2 Product information

### Technical data

Heater		V 7 S	
Heating medium		Air	
Control of the heat flow		Large	Small
Heat flow (watt)		12000	3000
Fuel consumption (l/h)		1.3	0.4
Heater air flow rate without counterpressure (kg/h)		310	–
Electr. power (watt)	in operation	115	125
	at start	360	
Rated voltage		24 volt	
Operating range Lower voltage limit: An undervoltage protection in the controller switches the heater off.		20 volt	
Upper voltage limit: An overvoltage protection in the controller switches the heater off.		26 volt	
Fuel See also operating instructions at fuel supply, page 23.		Commercially available diesel fuel (DIN EN 590) Fuel oil EL (commercially available)	
Heater code		8	
Tolerable operating temperature			
• Heater	Operation	–35 °C to +60 °C	
	Storage	–35 °C to +70 °C	
• Dosing pump	Operation	–40 °C to +70 °C	
	Storage	–40 °C to +85 °C	
Interference suppression		3 to DIN VDE 0879 part 3 (other measures possible)	
Weight		ca. 14 kg	



#### Caution!

#### Safety instructions for technical data!

Failure to comply with the technical data can result in malfunctions.

All technical data ±10 %



## 2 Product information

### Main dimensions

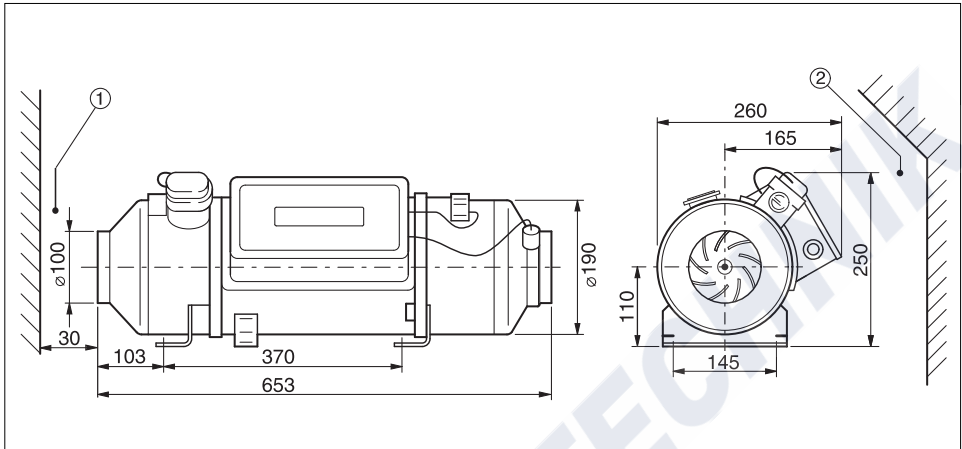

- ① Maintain sufficient space for the hot air intake.
- ② Maintain sufficient space for opening the lid and dismantling the glow plug and control box.

### 3 Installation

#### Installation and location

Installation in the driver's cab or passenger compartment of coaches and busses with more than 9 seats is not allowed. Exception see page 5, statutory regulations, arrangement of the heater.

The electronic control is integrated in the heater which makes wiring during installation much easier.

Fasten the heater with both consoles and 4 anti-vibration pads on the floor of the vehicle.

**Please note!**

- When fitting the heater, ensure there is sufficient space for heater air intake and for removing the glow plug and controller (see page 11, main dimensions).
- The regulations and safety instructions to be observed for this chapter are on page 4 – 7.

#### Location

##### Installation position in a coach or bus.

The heater is installed in a coach or bus preferably in a separate, splash-proof position outside the passenger compartment.

If there is no space available outside the passenger compartment, the heater can also be installed in a

box complying with the statutory regulations (see page 5) which has been sealed off from the passenger compartment.

The box must be ventilated to the outside. Break-throughs to the outside must be splash-proof.

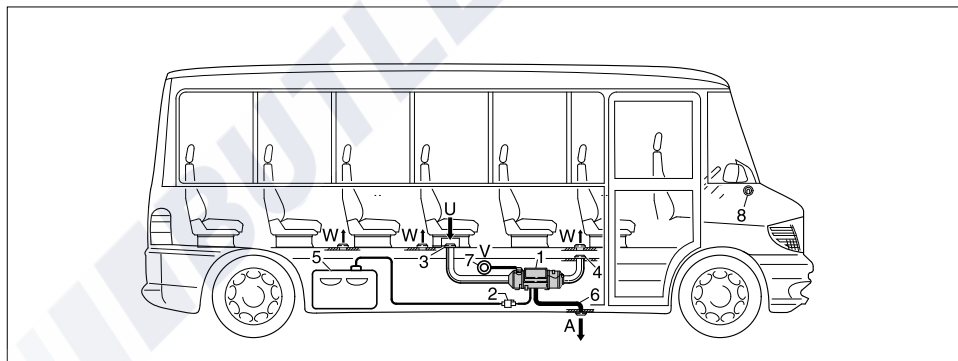

- |                                       |                         |                   |
|---------------------------------------|-------------------------|-------------------|
| 1 Heater                              | 5 Fuel tank             | U Air circulation |
| 2 Dosing pump                         | 6 Exhaust pipe          | V Combustion air  |
| 3 Heater air supply (air circulation) | 7 Combustion air supply | W Hot air         |
| 4 Heater air outlet                   | 8 Control element       | A Exhaust         |



### 3 Installation

#### Location

##### Installation position in a truck cargo compartment

For cargo compartment heating, the heater is fastened in a splash-proof position on the vehicle preferably in a box outside the cargo compartment. If no suitable place is available outside the cargo compartment, then the heater can also be fastened to the floor of the cargo compartment in a suitable position.



##### Caution!

The heater air outlets must be arranged in such a way that the flow of hot air is not impaired or hindered by the load.

The box must be ventilated to the outside. Break-throughs to the outside must be splash-proof.

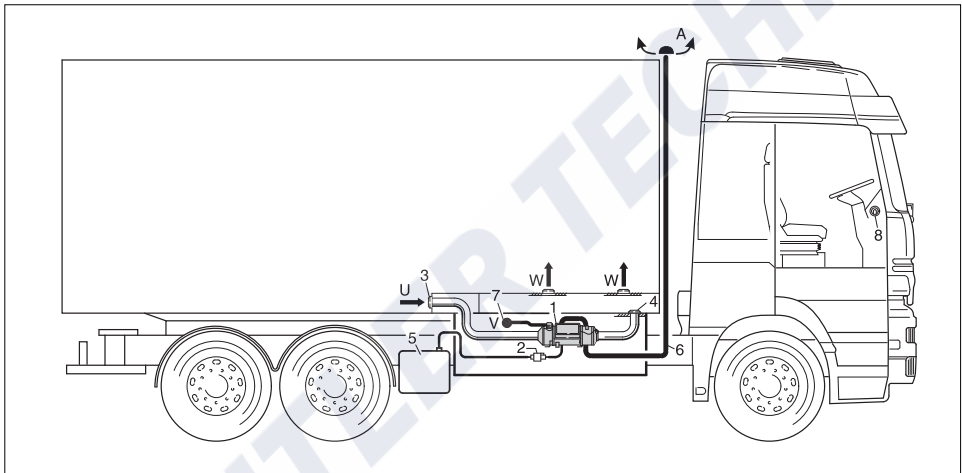

- |                                       |                         |                   |
|---------------------------------------|-------------------------|-------------------|
| 1 Heater                              | 5 Fuel tank             | U Air circulation |
| 2 Dosing pump                         | 6 Exhaust pipe          | V Combustion air  |
| 3 Heater air supply (air circulation) | 7 Combustion air supply | W Hot air         |
| 4 Heater air outlet                   | 8 Control element       | A Exhaust         |

#### Please note!

- The installation suggestions made in the installation instructions are just examples. Other installation locations are possible, as long as they correspond to the installation requirements stated in these instructions.
- Other installation information (e.g. for boats and ships) is available from the manufacturer on request.
- Observe the tolerable installation position together with the operating and storage temperatures.

### 3 Installation

#### Possible installation positions

The heater must be installed in its normal position, as shown in the drawing.

In heating mode, it is possible for the heater's position to deviate by up to  $\pm 15^\circ$  in all directions without impairing the heater function, for example when the vehicle is on a slope or when the heater is fitted on board a boat.

**Please note!**

Apart from this, after the heater has started up, continuous operation in a position deviating by  $\pm 30^\circ$  from the normal position is possible in the case of operating positions which change at short notice. The heater cannot operate if its position deviates by more than  $30^\circ$  from the normal position.

#### Normal position horizontal (exhaust connection downwards)

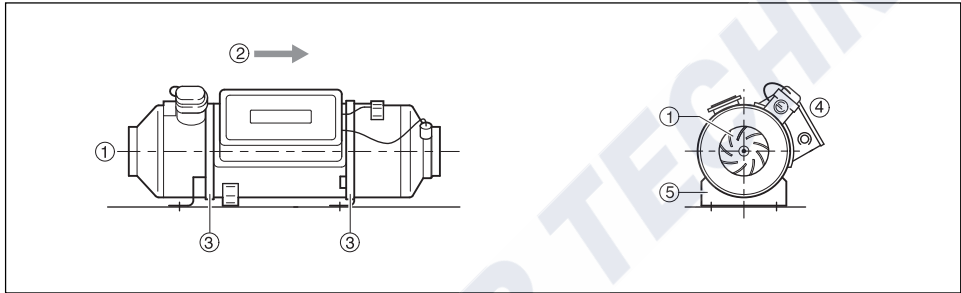

- ① Heater air intake opening (impeller)
- ② Direction of flow
- ③ Clamping strap
- ④ Position of the glow plug
- ⑤ Fastening bracket

#### Mounting and fastening

The heater can be fastened to the floor of the vehicle or to a vertical vehicle wall using the anti-vibration pads.

Drill the 4 holes for the two fastening brackets and the breakthrough for the exhaust pipe in the floor or wall of the vehicle.

After loosening the clamping straps ③, the fastening brackets ⑤ can be turned around the horizontal axis to adapt to the installation conditions.

If necessary, the fastening points should be reinforced!

**Please note!**

Comply with the prescribed installation position!

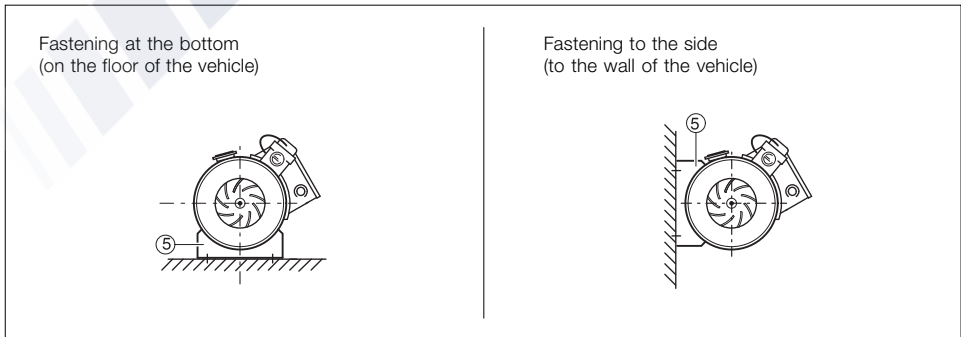



### 3 Installation

#### Nameplate

The nameplate is fastened in a clearly visible position to the jacket of the heater.  
The second nameplate (duplicate) is included in the scope of supply of the heater and can be adhered as required in a clearly visible position on or near the heater.

**Please note!**

The regulations and safety instructions to be observed for this chapter are stated on page 4 – 7.

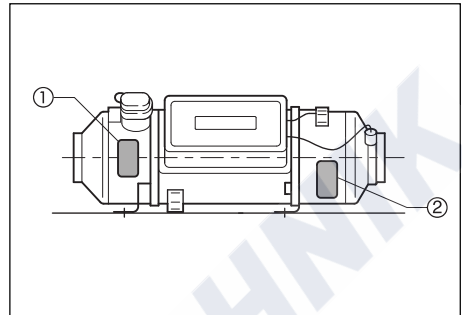

- ① Original nameplate
- ② Second nameplate (duplicate)

### 3 Installation

#### Heater air system

Parts for the heater air system are not included in the scope of supply and must be chosen as required from the accessories catalogue.

**⚠ Danger!**

**Risk of burning and injuries!**

- The hoses of the heater air system and the hot air outlet are to be routed and fastened in such a way that they pose no temperature risk to people, animals or materials sensitive to temperature from radiation / contact or blowing directly. If necessary, a cover is to be fitted to the heater air system or hot air outlet.
- The outflow hood must be fitted on the hot air outflow side. A safety grid must be fitted to the heater air intake side and outflow side if no air hoses are mounted, to prevent any injuries from the heater air fan or burns from the heat exchanger.
- High temperatures occur in the heater air system during and after the heater has been working. This is why it is important to avoid working in the vicinity of the heater air system while the heater is working. In such cases, switch the heater off beforehand and wait until all parts have cooled down completely. If necessary, wear safety gloves.

**Please note!**

- The regulations and safety instructions to be observed for this chapter are on page 4 – 7.
- Note the equipment code in the technical data (page 10) when connecting up air-conveying parts.

**⚠ Caution!**

- The heater air intake openings must be arranged in such a way that under normal circumstances, it is not possible for exhaust from the vehicle engine and heater to be sucked into the system, or for the heating air to be contaminated with dust, salt spray, etc.
- For circulating air, position the circulating air intake in such a way that the outflowing hot air cannot be directly sucked in again.
- In the event of possible overheating, increased heater air temperatures or surface temperatures can occur immediately before the defect shutdown.
- Only temperature-resistant hot air hoses approved by us must be used for the heater air system!
- When checking the functions, the mean outflow temperature measured after the heater has been running about 10 minutes at approx. 30 cm from the outlet should not exceed 110 °C (at an intake temperature of approx. 20 °C).

#### Heater air system (example)

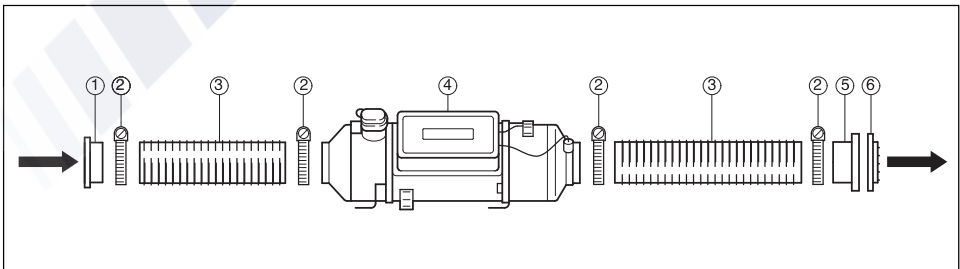

- ① Intake fitting with safety grid
- ② Hose clip
- ③ Flexible hose

- ④ Heater
- ⑤ Outlet fitting
- ⑥ Outflow





### 3 Installation

#### Exhaust system

##### Mounting the exhaust system

Fix the exhaust connection, with the seal and a hose clip, to the heater's exhaust flange.

Fix the  $\varnothing$  42 mm flexible exhaust pipe to the exhaust connection with a pipe clip. Lay the flexible exhaust pipe along the outer contour of the vehicle and use pipe clips to fix to the vehicle at suitable places.

The exhaust pipe can be between a minimum of 20 cm and a maximum of 3 m long, depending on the installation conditions.

After finishing all installation work, place an end sleeve on the exhaust pipe end.

##### Please note!

- The exhaust connection, seal and clip are included in the heater's scope of supply.
  - The  $\varnothing$  42 mm flexible exhaust pipe, the end sleeve and fastenings for the flexible exhaust pipe are not included in the scope of supply and have to be ordered separately, please refer to Page 8.
- For further exhaust system parts, please refer to the additional parts catalogue.

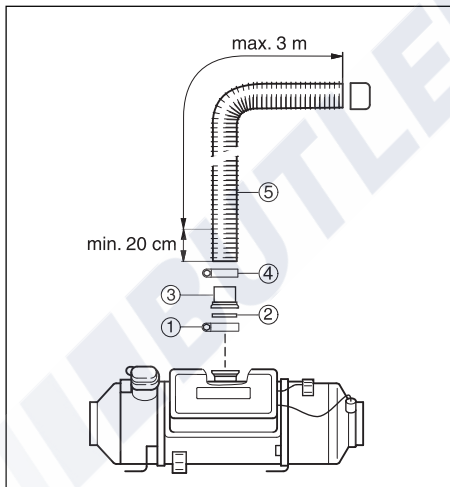

- ① Clip
- ② Seal
- ③ Exhaust pipe
- ④ Pipe clip
- ⑤ Flexible exhaust pipe  $\varnothing$  42 mm
- ⑥ End sleeve, exhaust



##### Caution!

##### Safety instructions!

The whole exhaust system gets very hot during and immediately after the heater has been working. This is the reason why the exhaust system must be installed according to these instructions.

- The exhaust outlet must end in the open air.
- The exhaust pipe must not protrude beyond the lateral limits of the vehicle.
- Install the exhaust pipe sloping slightly downwards. If necessary, make a drain hole approx.  $\varnothing$  5 mm at the lowest point to drain off condensation.
- Important functional parts of the vehicle must not be impaired (keep sufficient clearance).
- Mount the exhaust pipe with sufficient clearance to heat-sensitive parts. Pay particular attention to fuel pipes (plastic or metal), electrical cables and brake hoses etc.!
- Exhaust pipes must be fastened safely (recommended clearance of 50 cm) to avoid damage from vibrations.
- Route the exhaust system so that the emitted fumes are not sucked in with the combustion air.
- The mouth of the exhaust pipe must not get clogged by dirt and snow.
- The mouth of the exhaust pipe must not point in the direction of travel.



##### Danger!

##### Risk of injuries and burns!

Every type of combustion produces high temperatures and toxic exhaust fumes. This is the reason why the exhaust system must be installed according to these instructions.

- Do not perform any work on the exhaust system while the heater is working.
- Before working on the exhaust system, first switch the heater off and wait until all parts have cooled down completely, wear safety gloves if necessary.
- Do not inhale exhaust fumes.

##### Please note!

- The regulations and safety instructions to be observed for this chapter are on page 4 – 7.
- If a silencer is fitted, the exhaust end pipe must be much shorter than the flexible exhaust pipe between the heater and the exhaust silencer.

### 3 Installation

#### Combustion air system

##### Mounting the combustion air system

The combustion air is sucked in to the heater directly at the solenoid or through a flexible combustion air hose (inner Ø 25 mm, max. 3 m long).

The flexible combustion air hose can be shortened depending on the installation conditions.

Fasten the flexible combustion air hose to the heater with a pipe clip and to suitable places in the vehicle with hose clips or cable ties.

After completing all work, push an end sleeve over the flexible combustion air hose.

If no combustion air hose has been mounted, push the end sleeve onto the solenoid.



##### Caution!

##### Safety instructions for the combustion air system!

- The combustion air opening must be free at all times.
- Position the combustion air intake to be sure that exhaust fumes cannot be sucked in with the combustion air.
- Do not arrange the combustion air intake to pointing against the wind blast.
- The combustion air intake must not get clogged with dirt and snow.
- Install the combustion air intake system sloping slightly downwards. If necessary, make a drain hole approx. Ø 5 mm at the lowest point to drain off condensation.

##### Please note!

- The regulations and safety instructions to be observed for this chapter are on page 4 – 7.

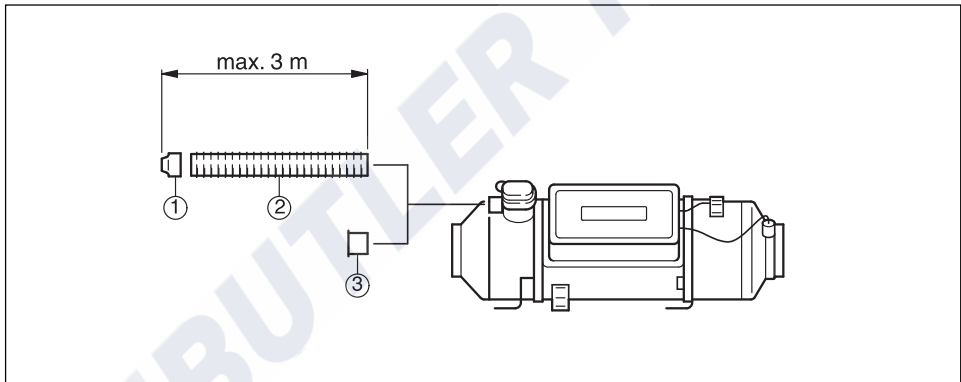

- ① End sleeve for combustion air hose
- ② Combustion air hose
- ③ End sleeve solenoid



### 3 Installation

#### Fuel supply

##### Mounting the dosing pump, routing the fuel pipes and mounting the fuel tank

The following safety instructions must be observed when mounting the dosing pump, routing the fuel pipes and mounting the fuel tank. Deviations from the instructions stated here are not allowed.

Failure to comply can result in malfunctions.



#### **Danger!**

##### **Risk of fire, explosion, poisoning and injuries!**

Caution when handling fuel.

- Switch off the vehicle engine and heater before refuelling and before working on the fuel supply.
- No naked lights when handling fuel.
- Do not smoke.
- Do not inhale petrol fumes.
- Avoid any contact with the skin.



#### **Caution!**

##### **Safety instructions for routing the fuel pipes!**

- Only use a sharp knife to cut off fuel hoses and pipes. Interfaces must not be crushed and must be free of burrs.
- The fuel pipe from the dosing pump to the heater should be routed at a continuous rise.
- Fuel pipes must be fastened safely to avoid any damage and / or noise production from vibrations (recommended clearance of approx. 50 cm).
- Fuel pipes must be protected from any mechanical damage.
- Route the fuel pipes so that any distortion of the vehicle, engine movements etc. cannot have any lasting effect on the service life.

- Parts carrying fuel must be protected from interfering heat.
- Never route or fasten the fuel pipes to the heater or vehicle exhaust system. When the systems cross, always ensure there is a sufficient heat clearance. If necessary, install heat deflection plates.
- Dripping or evaporating fuel must never be allowed to collect on hot parts or ignite on electric systems.
- When connecting fuel pipes with a fuel hose, always mount the fuel pipes in a butt joint to prevent any bubbles from forming.

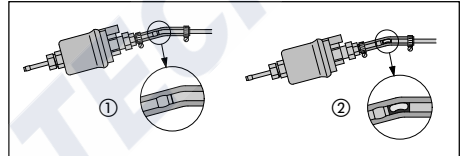

- ① Correct connection  
② Incorrect connection – bubble formation



##### **Safety instructions for fuel pipes and fuel tanks in buses and coaches**

- In buses and coaches, fuel pipes and fuel tanks must not be routed through the passenger compartment or driver's cab.
- Fuel tanks in buses and coaches must be positioned in such a way that the exits are not in direct danger from a possible fire.

#### **Please note!**

- The regulations and safety instructions to be observed for this chapter are on page 4 – 7.

### 3 Installation

#### Fuel supply

Fuel feed point with T-piece from the fuel supply line from the tank fitting to the vehicle engine

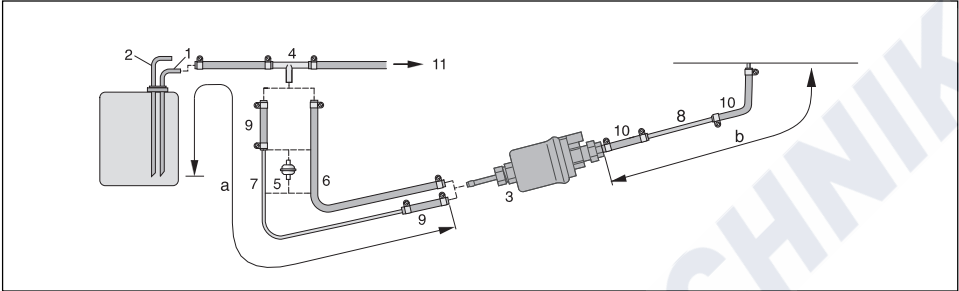

- ① Fuel feed pipe from tank connection
- ② Fuel return pipe to the tank connection
- ③ Dosing pump
- ④ T-piece
- ⑤ Fuel filter – only necessary for contaminated fuel.
- ⑥ Fuel hose, 5 x 3 (di = Ø 5 mm)
- ⑦ Fuel pipe, 6 x 1 (di = Ø 4 mm)
- ⑧ Fuel pipe, 4 x 1 (di = Ø 2 mm)
- ⑨ Fuel hose, 5 x 3 (di = Ø 5 mm), approx. 50 mm long
- ⑩ Fuel hose, 3,5 x 3 (di = Ø 3.5 mm), approx. 50 mm long
- ⑪ To the engine, mechanical fuel or injection pump.

#### Possible pipe lengths

**Intake side**      **Pressure side**  
a = max. 2 m      b = max. 6 m

#### Please note!

- Insert T-piece ④ before the fuel pump in the fuel feed pipe.
- Order no. for the parts of the fuel system: see accessories catalogue.

#### Installation position of the T-piece

Use the installation positions shown in the diagram when inserting a T-piece.

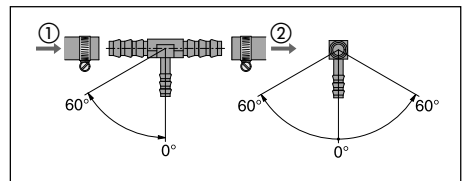

- ① Direction of flow from the fuel tank
- ② Direction of flow to the vehicle engine



### 3 Installation

#### Fuel supply

Fuel feed point with tank connection – ascending pipe, integrated in the vehicle tank or in the tank fitting

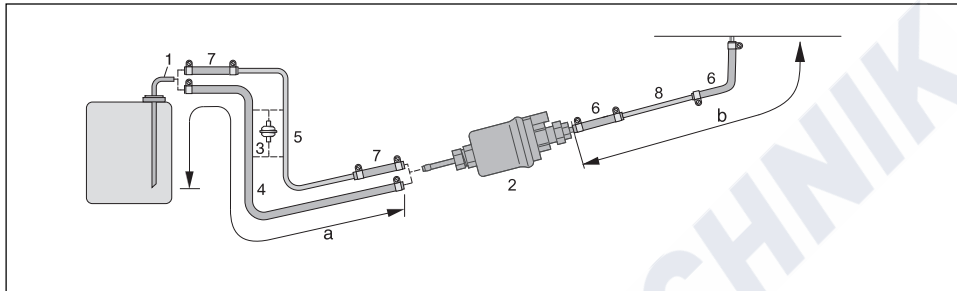

- ① Tank connection for metal tank, di = Ø 4 mm
- ② Dosing pump
- ③ Fuel filter – only necessary for contaminated fuel.
- ④ Fuel hose, 5 x 3 (di = Ø 5 mm)
- ⑤ Fuel pipe, 6 x 1 (di = Ø 4 mm)
- ⑥ Fuel hose, 3.5 x 3 (di = Ø 3.5 mm), approx. 50 mm long
- ⑦ Fuel hose, 5 x 3 (di = Ø 5 mm), approx. 50 mm long
- ⑧ Fuel pipe, 4 x 1 (di = Ø 2 mm)

#### Possible pipe lengths

Intake side  
a = max. 2 m

Pressure side  
b = max. 6 m

#### Please note!

- Order no. for the parts of the fuel system: see accessories catalogue



#### Caution!

#### Safety instructions for the fuel supply!

- The fuel must not be conveyed by gravity or overpressure in the fuel tank.
- Withdrawal of fuel after the vehicle's fuel pump is not allowed.
- When the pressure in the fuel pipe is more than 0.2 bar to max. 2 bar, use a pressure reducer (order no. 22 1000 20 09 00) or separate tank connection.
- When the pressure in the fuel pipe is more than 2 bar or there is a non-return valve in the return pipe (in the tank), a separate tank connection must be used.
- When using a T-piece in a plastic pipe, always use support sleeves in the plastic. Connect the T-piece and the plastic pipe with corresponding fuel hoses and secure with hose clips.

### 3 Installation

#### Fuel supply

##### Installation position of the dosing pump

Always mount the dosing pump with the pressure side rising upwards. Every installation position over 15° is allowed, although an installation position between 15° and 35° is preferable.

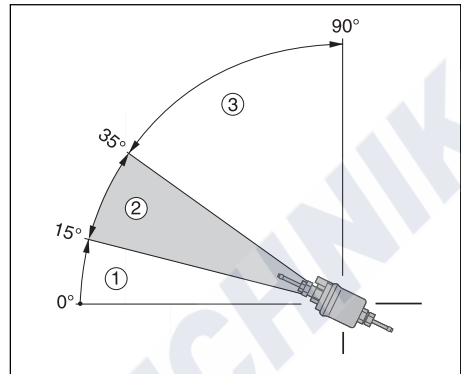

- ① Installation position between 0° and 15° is not allowed.
- ② Preferred installation position in range 15° to 35°.
- ③ Installation position in range 35° to 90° is allowed.

##### Possible suction and pressure height of the dosing pump

Pressure height from vehicle tank to dosing pump:  
a = max. 1000 mm

Intake height in pressure-less vehicle tank:  
b = max. 750 mm

Intake height in vehicle tanks with withdrawal by negative pressure (valve with 0.03 bar in tank cap):  
b = max. 400 mm

Pressure height of the dosing pump to the heater:  
c = max. 2000 mm

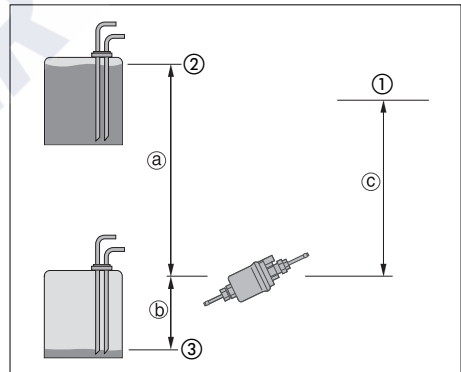

- ① Connection to heater
- ② Max. fuel level
- ③ Min. fuel level

**Please note!**

Check tank venting.



**Caution!**

##### Safety instructions for installing the dosing pump

- Always mount the dosing pipe with the pressure side rising upwards – minimum incline 15°.
- Protect the dosing pump and filter from intolerable heat, do not mount near to the silencers and exhaust pipes.



### 3 Installation

#### Fuel supply

##### Fuel quality

The heater can run on commercially available diesel fuel as per DIN EN 590 as used in the vehicle tank.

##### Fuel for special cases

In special cases (above 0 °C), the heater can also run on fuel oil EL or paraffin.

##### Fuel for low temperatures

Refineries and fuel service stations automatically adjust the fuel to normal winter temperatures (winter diesel). This means that difficulties are only to be expected for extreme drops in temperature, as also apply to the vehicle engine. Please also refer to the vehicle manual.

If the heater is run from a separate tank, please comply with the following rules:

For temperatures above 0 °C, any kind of diesel fuel as per DIN EN 590 can be used.

If no special diesel fuel is available for low temperatures, then paraffin or petrol should be mixed with the fuel according to the following table:

Temperature	Winterdiesel	Addition
0 °C to -25 °C	100 %	-
-25 °C to -40 °C	50 %*	50 % paraffin or petrol

\* or 100 % special cold diesel fuel (Arctic diesel)

##### Operation with biodiesel (PME)

The heater is **not** certified for operation with biodiesel.

##### Please note!

- Mixtures with used oil are **not** allowed!
- After refuelling with winter or cold diesel or the listed blends, the fuel pipes and the dosing pump must be filled with the new fuel by letting the heater run for 15 mins.!

## 4 Operation and function

### Operating instructions

#### Switch on the heater – "Heat"

Set the switch to "Heat", the heater starts and the green operating display lights up.

#### Temperature selection with the temperature controller

The required interior temperature is preselected using the rotary knob of the temperature controller. The interior temperature can be between +10 °C and +30 °C, depending on the size of the space to be heated and the prevailing outdoor temperature. The selected rotary knob setting is an empirical value.

#### Switch on the heater – "Ventilate"

Set the switch to "Ventilate", the heater's hot air fan starts in "High" control stage and ventilates the vehicle interior.

#### Switch off heater

The green operating display switches off and at the same time the heater starts the fan after-run for approx. 3 minutes for cooling down.

The heater then automatically switches off.

#### Please note!

The "Heat – Off – Ventilate" switch and the temperature controller are included in the scope of supply. Both components are required for running the heater.

### Important instructions for operation

#### Safety checks before the start

After a longer interval in operations (after the summer months) the fuse must be put in position and / or the heater connected up to the battery. Check that all parts fit firmly (tighten screws where necessary). Check the fuel system visually for any leaks.

### Initial commissioning

The following points are to be checked by the company installing the heater during initial commissioning.

- After installation of the heater, the coolant circuit and the whole fuel supply system must be vented carefully. Comply with the instructions issued by the vehicle manufacturer.
- During the trial run of the heater, check all water and fuel connections for leaks and firm fitting.
- If the heater shows a fault during operation, find and eliminate the cause of the fault using a diagnosis unit.

#### Please note!

During the initial start-up of the heater, odours can be produced for a short time. This is fully normal during the first few minutes of operation and does not indicate a malfunction in the heater.





## 4 Operation and function

### Operating instructions

#### Switching on

When the heater is switched on, the control lamp in the control element lights up.

The glow plug is switched on and the fan starts at maximum speed.

A timer relay ensures that the voltage at the glow plug does not exceed the permissible range.

#### Starting the heater

After approx. 25 seconds, the dosing pump starts to supply fuel for the control stage "LARGE". Once a stable flame has been produced and the flame sensor has detected the flame, the glow plug is switched off again after approx. 10 seconds.

The heater is compelled to run for at least 30 seconds in the "LARGE" stage. The heat flow can only be adjusted after this period.

#### Control in the heating mode

During the heating mode, the room temperature or the temperature of the sucked in heating air is constantly measured.

If the temperature is higher than the temperature selected on the control element, the heater starts to regulate its output. There are two stages "LARGE" and "SMALL" so that the outflow of heat produced by the heater can be adjusted to the heating requirements. Fan speed and fuel quantity correspond to the particular control stages.

If the set temperature is still exceeded in the "SMALL" stage, the heater switches "OFF" with the fan running on for approx. 3 minutes to cool off.

If the room temperature falls below the set value, the heater starts up again in the control stage "LARGE".

#### Switching off

When the heater is switched off, the control lamp goes off and the fuel supply is switched off.

The fan runs on for approx. 3 minutes to cool down.

## 4 Operation and function

### Control and safety devices

- The flame is monitored by the flame sensor, and the maximum tolerable temperature by the overheating sensor. Both influence the controller which switches the heater off in the case of any defects.
- If the heater does not ignite within 90 seconds after the fuel pump is started, the start is repeated. If the heater still does not ignite after another 90 seconds of pumping fuel, a safety lock-out occurs, i. e. the fuel supply is off and the fan continues to run for approx. 4 minutes. After an impermissible number of failed start attempts, the controller is locked.\*
- If the flame goes off by itself during operation, the heater is restarted.  
If the heater does not ignite within 90 seconds after the fuel pump has started, or ignites and goes off again within 10 minutes, the heater is switched off, i.e. the fuel pump stops and the fan runs on for approx. 3 minutes.  
This status can be remedied by briefly switching off and on again.  
Do not repeat the switching off / on routine more than twice.
- In the case of overheating, the overheating sensor responds, the fuel delivery is interrupted and a safety lock-out occurs. Once the cause of the overheating has been eliminated, the heater can be restarted by switching it off and on again.
- If the lower or upper voltage limit is reached, the heater is switched off approx 20 sec.
- The heater does not start up when the glow plug is defect or when the electric lead to the dosing pump is interrupted.
- During the start procedure, the function of the fan motor is checked once. If the fan motor does not start, the heater switches off.  
During operation, the fan motor is monitored in cycles (4 min.). If the motor speed is below the permitted limit, the heater switches off.

#### Please note!

- Do not switch the heater off and on again more than twice.
- Fault display signals can be accessed with an additional device, see troubleshooting instructions.

#### Emergency shutdown – EMERGENCY OFF

If an emergency shutdown – EMERGENCY OFF – is necessary during operation, proceed as follows:

- Switch the heater off with the control or
- pull the fuse out or
- disconnect the heater from the battery.



## 5 Electrical system

### Heater wiring



#### Caution!

#### Safety instructions for wiring the heater!

The heater is to be connected up electrically according to the EMC directives.

EMC can be affected if the heater is not connected up correctly. For this reason, comply with the following instructions:

- Ensure that the insulation of electrical cables is not damaged. Avoid: chafing, kinking, jamming or exposure to heat.
- In waterproof connectors, seal any connector chambers not in use with filler plugs to ensure they are dirt-proof and water-proof.
- Electrical connections and ground connections must be free of corrosion and firmly connected.
- Lubricate connections and ground connections outside the heater interior with contact grease.

#### Please note!

Comply with the following when wiring the heater and the control element:

- Electrical leads, switchgear and controllers must be arranged in the vehicle so that they can function perfectly under normal operating conditions (e.g. heat exposure, moisture etc.).
- The following cable cross sections are to be used between the battery and heater. This ensures that the max. tolerable voltage loss in the cables does not exceed 0.5 V for 12 V or 1 V for 24 V rated voltage (plus cable + minus cable).  
Cable cross sections for a cable length of:
  - up to 5 m = cable cross section 4 mm<sup>2</sup>
  - from 5 to 8 m = cable cross section 6 mm<sup>2</sup>
- If the plus cable is to be connected to the fuse box (e.g. terminal 30), the vehicle cable from the battery to the fuse box must be included in rating the overall cable length and possibly re-dimensioned if necessary.
- Insulate unused cable ends.

# 5 Electrical system

## Circuit diagram heater V 7 S

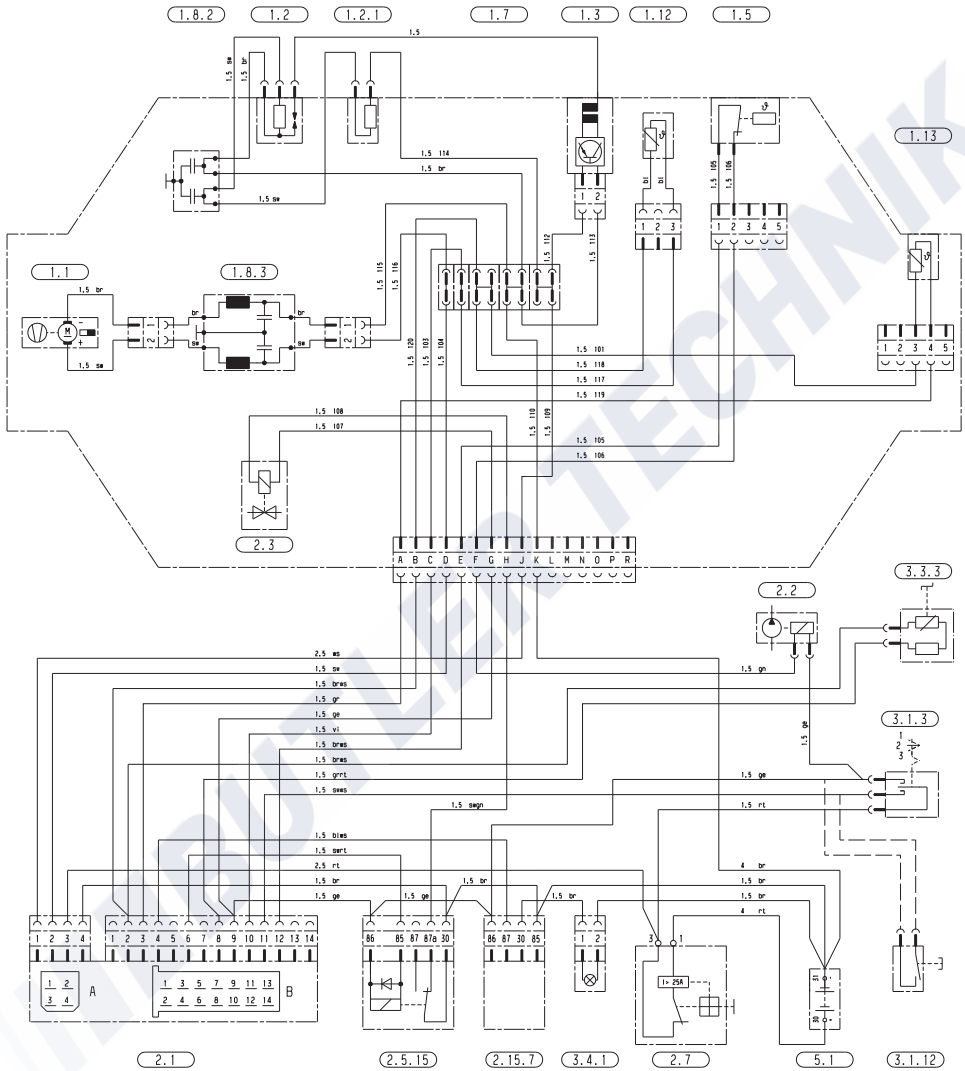



## 5 Electrical system

### Parts list for the circuit diagram

#### Parts list heater V 7 S

- 1.1 Burner engine
- 1.2 Glow plug
- 1.2.1 Resistance for glow plug
- 1.5 Overheating sensor
- 1.7 Printed circuit board
- 1.8.2 Supression capacitor
- 1.8.3 Supression filter
- 1.12 Flame sensor
- 1.13 Temperature sensor
  
- 2.1 Controller
- 2.2 Dosing pump
- 2.3 Air solenoid (for combustion air)
- 2.5.15 Relais for solenoid valve
- 2.7 Main fuse, 24 A
- 2.15.7 Amplifier
  
- 3.1.3 Button heating – off – ventilate
- 3.1.12 Fault code query
- 3.3.3 Temperaturregler
- 3.4.1 Operating display
  
- 5.1 Battery

#### Cable colours

- rt = red
- bl = blue
- ws = white
- sw = black
- gn = green
- gr = grey
- ge = yellow
- vi = violet
- br = brown
- li = purple

## 6 Troubleshooting / Maintenance / Service

---

### In case of faults, please check the following points

- If the heater does not start after being switched on:
  - Switch the heater off and on again.
- If the heater still does not start, check whether:
  - There is fuel in the tank?
  - The fuses are OK?
  - The electrical cables, connections etc. are OK?
  - Anything is clogging the combustion air supply or exhaust system?

### Troubleshooting

If the heater remains faulty even after these points have been checked, or another malfunction occurs in your heater, please contact:

- For installation ex works, your contract workshop.
- For subsequent installation, the workshop who installed your heater.

**Please note!**

Please note that warranty claims can become void if the heater is changed by a third party or by this installation of third party parts.

### Maintenance instructions

- Switch the heater on once a month for about 10 minutes, even outside the heating period.
- Before the heating period starts, the heater should undergo a trial run. If persistent extreme smoke develops, unusual burning noises or a clear fuel smell can be perceived or if electric / electronic parts heat up, the heater must be switched off and put out of service by removing the fuse. In this case, the heater should not be started up again until it has been checked by qualified staff who have been trained on Eberspächer heaters.
- Check the openings of the combustion air supply and exhaust system after longer standstill periods, clean if necessary!

### Service

If you have any technical queries or problems with your heater, dial the following service phone number:

Hotline  
Phone: 00 49 (0)800 / 12 34 300

Fax hotline  
Fax 00 49 (0)1805 / 26 26 24



## 7 Environment

### Certification

The high quality of Eberspächer's products is the key to our success.

To guarantee this quality, we have organised all work processes in the company along the lines of quality management (QM).

Even so, we still pursue a large number of activities for continuous improvement of product quality in order to keep pace with the similarly constantly growing requirements made by our customers.

All the steps necessary for quality assurance are stipulated in international standards.

This quality is to be considered in a total sense.

It affects products, procedures and customer / supplier relationships.

Officially approved public experts assess the system and the corresponding certification company awards a certificate.

Eberspächer has already qualified for the following standards:

**Quality management as per  
DIN EN ISO 9001:2000 and ISO/TS 16949:1999**

**Environment management system as per  
DIN EN ISO 14001:1996**

### Disposal

#### Disposal of materials

Old devices, defect components and packaging material can all be separated and sorted into pure-grade fractions so that all parts can be disposed of as required in an environment-friendly manner or recycled where applicable.

Electric motors, controllers and sensors (e.g. temperature sensors) are deemed to be "electronic scrap".

#### Dismantling the heater

The heater is dismantled according to the repair stages in the current troubleshooting / repair instructions.

#### Packaging

The packaging of the heater can be kept in case it has to be sent back.

### EU Declaration of Conformity

With regard to the following products

#### air heater type V 7 S

we herewith confirm that it conforms with the prime safety requirements stipulated in the directives of the EU Council for harmonisation of the legal regulations of the member states with regard to electromagnetic compatibility (89 / 336 / EEC).

This declaration applies to all heaters produced according to the production drawings V 7 S which are an integral part of this declaration.

The following standards/directives have been used to assess the product with regard to electromagnetic compatibility:

- EN 50081 – 1 Basic form interference emission.
- EN 50082 – 1 Basic form interference resistance.
- 72 / 245 / EEC – Modification status 2006 / 96 / EC interference suppression in motor vehicles.

## 8 Lists

### List of key words A – Z

<b>Keyword</b>	<b>Page</b>	<b>Keyword</b>	<b>Page</b>
<b>A</b>		<b>I</b>	
Accident prevention .....	7	Instructions .....	4, 5
Ambient temperature .....	10	Installation .....	12 – 23
<b>C</b>		Installation area .....	12, 13
Certificates .....	31	Interference suppression class .....	10
Circuit diagram .....	28	Initial commissioning .....	24
Combustion air system .....	18	Installation location .....	12, 13
Control devices .....	26	Installation position .....	14
Control in heating mode .....	25	Information .....	4
Contents .....	2	<b>M</b>	
<b>D</b>		Maintenance .....	30
Declaration of conformity .....	31	Main dimensions .....	11
Disposal .....	31	<b>N</b>	
Dosing pump .....	19 – 22	Nameplate .....	15
<b>E</b>		<b>O</b>	
Electronic components .....	27 – 29	Operation .....	24 – 26
Emergency off .....	26	Operating instructions .....	24, 25
Emergency stop .....	26	<b>P</b>	
Environment protection .....	31	Picture symbols .....	4
EU Declaration of Conformity .....	31	Power consumption .....	10
Extra parts .....	8	Pressure height .....	22
Exhaust .....	17	Pressure side .....	20, 21
Exhaust system .....	17	Presentation .....	4
<b>F</b>		Purpose .....	4
Faults .....	30	<b>R</b>	
Fastening .....	14	Rated voltage .....	10
Formation of air bubbles .....	19	Regulations .....	5, 6
Fuel .....	5, 19 – 23	<b>S</b>	
Fuel withdrawal .....	19 – 23	Safety devices .....	26
Fuel system .....	19 – 23	Safety check (before starting) .....	24
Fuel quality .....	23	Scope of supply .....	9
<b>H</b>		Storage temperature .....	10
Heat flow .....	10	Statutory regulations .....	5, 6
Heating operation .....	25	Start procedure .....	25
Heater air system .....	16	Suction height .....	22
Hotline .....	30	Switching on .....	25
		Switching off .....	25





**8 Lists**

**List of key words A – Z**

<b>Keyword</b>	<b>Page</b>
<b>T</b>	
Technical data .....	10
Test symbol .....	5
Text structure .....	4
T-piece .....	20
Troubleshooting .....	30
<b>U</b>	
Use .....	4
<b>V</b>	
Voltage .....	10
Voltage limit .....	10
<b>W</b>	
Weight .....	10
Wiring .....	27

**List of abbreviations**

- ADR**  
European agreement about the international transport of dangerous goods on the road.
- ADR99**  
Dangerous goods regulations for France.
- EC type approval**  
Permit awarded by the Federal Vehicle Office for the production of a heater for installation in motorised vehicles.
- EMC directive**  
Electromagnetic compatibility.
- JE partner**  
J. Eberspächer partner.
- PME**  
Biodiesel as per DIN V 51606.

/// BUTLER TECHNIK

/// BUTLER TECHNIK

/// BUTLER TECHNIK