

TROUBLESHOOTING AND REPAIR INSTRUCTIONS

AIR HEATER V 7 S



THE TROUBLESHOOTING AND REPAIR INSTRUCTIONS ARE ONLY VALID FOR THE FOLLOWING ENGINE-INDEPENDENT AIR HEATERS

Heaters for diesel

V 7 S – 24 V 25 1728 00 00 00

V 7 S – 24 V 25 2239 05 00 00

CONTENTS

CONTENTS

This list of contents gives you precise information about the contents of the Troubleshooting and Repair Instructions.

If you are looking for a term, technical term or you would like an abbreviation explained, please use the relevant index at the end of the instructions.

CHAPTER	TITLE	CONTENT	PAGE
1	Introduction	Foreword	5
		Special text structure, presentation and picture symbols	5
		– Special text formats and presentations	5
		– Picture symbols	5
		Heater documentation	5
		– Content and purpose of these troubleshooting and repair instructions	5
		Further documentation	5
		– Technical description, installation, operating and maintenance instructions	5
		– Spare parts list	5
		Safety instructions for installation and repair	6
		Liability claim / Warranty	6
		Accident prevention	6
		Initial start-up of the heater or functional test after a repair	6
		2	Function and operation
Functional description	8		
– Switching on	8		
– Starting the heater	8		
– Control in heating mode	8		
– Switching off	8		
Control and safety devices	8		
Emergency shutdown – EMERGENCY OFF	8		
3	Technical data	Diesel air heater	9
		Control values	10
4	Troubleshooting	What to check first in case of faults	11
		Overview of testing equipment	11
		– Call up diagnostic signals	11
		Fault diagnosis using the diagnostic unit	12
		JE diagnostic unit connection at the control box	12
		Query the fault memory	13
		Display of the fault memory F1 – F5 or F5 – F1	13
		Delete fault memory	13
		Cancel the control box lock	13
		Fault code display	14

CONTENTS

5	Repair instructions	Safety instructions to be noted and followed before working on the heater	16
		Parts list for assembly drawing	16
		Assembly drawing	17
		Repair steps	18
		View of complete unit	18
		Dismantle the heater	19
		Repair step 1	19
		– Dismantle maintenance cover from protective casing	19
		Repair step 2	19
		– Dismantle glow plug and check its function	19
		Repair step 3	20
		– Dismantle series resistor for glow plug	20
		Repair step 4	21
		– Dismantle solenoid valve for combustion air	21
		Repair step 5	21
		– Dismantle ignition spark generator	21
		Repair step 6	22
		– Dismantle radio interference suppression capacitor	22
		Repair step 7	22
		– Dismantle the overheating switch	22
		Repair step 8	23
		– Dismantle temperature sensor	23
		Repair step 9	23
		– Dismantle outer jacket, hood and brackets	23
		– Dismantle outer jacket, hood and brackets	24
		Repair step 10	24
		– Dismantle flame sensor	24
		Repair step 11	25
		– Dismantle blower from heat exchanger	25
		Repair step 12	25
		– Dismantle impeller	25
		Repair step 13	26
		– Pull off coupling	26
		Repair step 14	26
		– Dismantle rotary distributor	26
		Repair step 15	26
		– Dismantle combustion chamber lining	26
		Check fuel supply	27
		Measuring the fuel quantity	27
		– Preparing for the measurement	27
		– Measurement	27
		– Evaluation	27

CONTENTS

6	Circuit diagram	Parts list for circuit diagram, heater	28
		– Cable colours	28
		Heater circuit diagram	29
7	Service	Certifications	30
		Disposal	30
		– Disposal of materials	30
		– Dismantling the heater	30
		– Packaging	30
		EC Declaration of Conformity	30
		List of abbreviations	31

1 INTRODUCTION

FOREWORD

These Troubleshooting and Repair Instructions are applicable to the heaters listed on the title page, to the exclusion of all liability claims. Depending on the version or revised status of the heater, there may be differences between it and these troubleshooting and repair instructions. The user must check this before carrying out the repair work and, if necessary, take the differences into account.

SPECIAL TEXT STRUCTURE, PRESENTATION AND PICTURE SYMBOLS

Special text formats and picture symbols are used in these instructions to emphasise different situations and subjects. Please refer to the following examples for their meanings and appropriate action.

SPECIAL TEXT FORMATS AND PRESENTATIONS

- This dot (▪) indicates a list, which is started by a heading.
 - If an indented dash (–) follows a “dot”, this list is a sub-section of the black dot.

Underlined blue text denotes a cross-reference, which can be clicked in the PDF format. The part of the document named in the text is then displayed.

PICTURE SYMBOLS



This information points out a potential serious or fatal danger. Ignoring this information can result in severe injuries.

- ➔ This arrow indicates the appropriate precaution to take to avert the danger.



This information points out a dangerous situation for a person and / or the product. Failure to comply with these instructions can result in injuries to people and / or damage to machinery.

- ➔ This arrow indicates the appropriate precaution to take to avert the danger.



These remarks contain recommendations for use and useful tips for the operation, installation and repair of the heater.

HEATER DOCUMENTATION

CONTENT AND PURPOSE OF THESE TROUBLESHOOTING AND REPAIR INSTRUCTIONS

These instructions are to be used to correct faults and to perform repairs on the heater. The work required for this may only be done by personnel appropriately trained by a JE service partner.

FURTHER DOCUMENTATION

TECHNICAL DESCRIPTION, INSTALLATION, OPERATING AND MAINTENANCE INSTRUCTIONS

This documentation provides the JE service partner with all the necessary technical information, describes the correct installation in accordance with the regulations and provides the customer with the necessary information for safe operation of the heater.

SPARE PARTS LIST

The spare parts list provides the JE service partner with the necessary information for ordering spare parts in case of repairs.

1 INTRODUCTION

SAFETY INSTRUCTIONS FOR INSTALLATION AND REPAIR

CAUTION!

Improper installation or repair of Eberspächer heaters can cause a fire or result toxic exhaust entering the inside of the vehicle.

This can cause serious and even fatal risks.

- The heater may only be installed according to the specifications in the technical documents or repaired using original spare parts by authorised and trained persons.
- Installation and repairs by unauthorised and untrained persons, repairs using non-original spare parts and without the technical documents required for installation and repair are dangerous and therefore are not permitted.
- A repair may only be carried out in connection with the respective unit-related technical description, installation instructions, operating instructions and maintenance instructions.
This document must be carefully read through before / during installation and repair and followed throughout. Particular attention is to be paid to the official regulations, the safety instructions and the general information.

PLEASE NOTE!

- The relevant rules of sound engineering practice and any information provided by the vehicle manufacturer are to be observed during the installation and repair.
- When carrying out electric welding on the vehicle, the positive cable at the battery should be disconnected and placed at ground to protect the control box.

LIABILITY CLAIM / WARRANTY

Eberspächer does not accept any liability for defects and damage, which are due to installation or repair by unauthorised and untrained persons.

Compliance with the official regulations and the safety instructions is prerequisite for liability claims.

Failure to comply with the official regulations and safety instructions leads to exclusion of any liability of the heater manufacturer.

ACCIDENT PREVENTION

General accident prevention regulations and the corresponding workshop and operating safety instructions are to be observed.

INITIAL START-UP OF THE HEATER OR FUNCTIONAL TEST AFTER A REPAIR

- After installing or carrying out a repair on the heater, the whole fuel supply system must be carefully vented.
- Comply with the instructions issued by the vehicle manufacturer.
- During the heater trial run, all fuel connections must be checked for leaks and secure, tight fit.
- If faults occur while the heater is running, use a diagnostic unit to correct the cause of the fault.

2 FUNCTION AND OPERATION

CUTAWAY VIEW

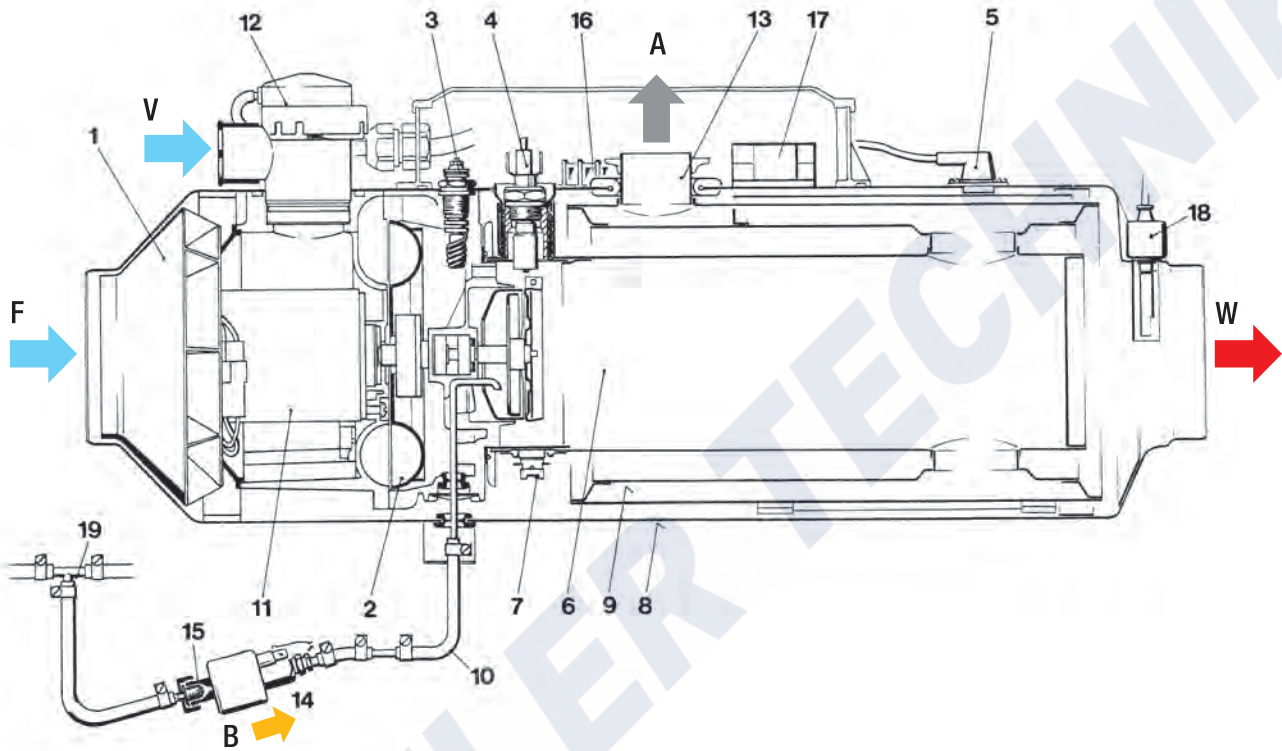

- 1 Hot air impeller
- 2 Combustion air impeller
- 3 Glow plug (series resistor)
- 4 Glow plug
- 5 Overheating switch
- 6 Combustion chamber
- 7 Flame sensor
- 8 Outer jacket
- 9 Heat exchanger
- 10 Fuel line
- 11 Blower motor
- 12 Combustion air solenoid valve

- 13 Exhaust pipe
- 14 Metering pump
- 15 Fuel strainer
- 16 Connector strip
- 17 Ignition spark generator
- 18 Temperature sensor
- 19 Fuel branch
- A = Exhaust
- B = Fuel
- F = Fresh air
- V = Combustion air
- W = Hot air

2 FUNCTION AND OPERATION

FUNCTIONAL DESCRIPTION

SWITCHING ON

When the heater is switched on, the green operating display lights up. The glow plug is switched on and the fan starts at maximum speed. A clock relay ensures that the voltage at the glow plug does not exceed the allowable range.

STARTING THE HEATER

After approx. 25 sec. the metering pump starts pumping the fuel for the "HIGH" control stage.

After a stable flame has formed and the flame sensor has detected the flame, the glow plug is switched off after approx. 25 sec.

The heater continues running, positively controlled, for at least 30 sec. in "HIGH" control stage. Only then can the heat flow be controlled.

CONTROL IN HEATING MODE

During heating mode the hot air outlet temperature is constantly measured.

If the hot air outlet temperature is higher or lower than the temperature set at the temperature controller, the control starts.

Control stages "HIGH" and "LOW" are provided, so that it is possible to adjust the heat flow supplied by the heater to the heat requirement.

If the set temperature is still exceeded in "LOW" control stage, the heater nevertheless remains in "LOW" control stage.

SWITCHING OFF

When the heater is switched off, the green operating display goes out.

The fuel pumping is switched off.

The fan runs on for approx. 3 minutes to cool down.

CONTROL AND SAFETY DEVICES

- The flame is monitored by the flame sensor, the maximum allowable temperature is monitored by the overheating switch. Both affect the control box which switches off the heater in the event of faults.
- If the heater does not ignite within 90 seconds after the fuel starts to pump, the start is repeated.
- If the heater still does not ignite after another 90 seconds of pumping fuel, a safety lock-out occurs, i.e. the fuel supply is off and the fan continues to run for approx. 3 minutes.
- If the flame goes off by itself during operation, the heater is restarted.
- If the heater still does not ignite within 90 seconds after the fuel pump has been restarted, or ignites but goes off again within 10 minutes, a safety lock-out occurs, i.e. the fuel supply is off and the fan continues to run for approx. 3 minutes.
The shutdown on faults can be cancelled by briefly switching off and on again.
Do not repeat the switching off / on routine more than twice.
- In the case of overheating, the overheating sensor triggers, the fuel feed is interrupted and a shutdown on faults occurs.
If overheating is the cause of a shutdown on faults, the green operating display flashes regularly.
After the cause of the overheating has been eliminated, the heater can be re-started by switching it off and on again.
- If the lower or upper voltage limit is reached, a shutdown on faults occurs after approx. 20 seconds.
- The heater does not start up if the glow plug is defective or if the electric lead to the metering pump is interrupted.
- On starting, the function of the blower motor is tested. If the blower motor does not start up, the heater switches to fault.
During operation, the blower motor is cyclically (4 min.) monitored. A shutdown on faults occurs if the motor speed is below the allowable limit.

PLEASE NOTE!

- Do not repeat the switching off / on routine more than twice.
- Fault display signals can be called up using an additional device, see Troubleshooting and Repair Instructions.

EMERGENCY SHUTDOWN – EMERGENCY OFF

If an emergency shutdown – EMERGENCY OFF – is necessary during operation, proceed as follows:

- Switch the heater off at the control unit or
- remove the fuse or
- disconnect the heater from the battery.

3 TECHNICAL DATA

DIESEL AIR HEATER

Heater type		V 7 S	
Heating medium		Air	
Control of the heat flow		High	Low
Heat flow (W)		12 000	3000
Heater air flow rate without counterpressure (kg/h)		310	
Heater code		8	
Fuel		Diesel – standard commercially available (EN 590) Heating oil EL (standard commercially available)	
Fuel consumption (l/h)		1.3	0.4
Rated voltage (V)		24	
Electrical power consumption (W)		during operation	115
		while starting	360
Operating range			
Lower voltage limit: An undervoltage protection installed in the control box switches off the heater if the lower voltage limit is reached.		20 V	
Upper voltage limit: An overvoltage protection installed in the control box switches off the heater if the upper voltage limit is reached.		28 V	
Hot air intake temperature		max. +60 °C	
Allowable ambient temperature		during operation	without operation
		Heater	–40 °C to +60 °C
		Control box	–40 °C to +75 °C
		Metering pump	–40 °C to +80 °C
Interference suppression class		5 VHF / 4 SW / 5 MW to EN 55025	
Weight		approx. 14 kg	
Ventilation mode		possible with corresponding circuit	



CAUTION!

Operating the heater outside the specified technical data can cause malfunctions.

→ The technical data must be complied with at all times.



PLEASE NOTE!

If no limit values are given, the technical data listed is with the usual heater tolerances of ± 10 % at nominal voltage and Esslingen reference altitude.

3 TECHNICAL DATA

CONTROL VALUES

Speed of the blower motor (at rated voltage)

- High
- Low
- After-run

3400 1/min. +300 1/min.

Solenoid valve	approx. 100 Ω at approx. 25 °C
Metering pump	approx. 20 Ω
Glow plug	approx. 1 Ω
Potentiometer with series resistor	680 Ω to 1150 Ω
Overheating switch	Switching values 70 °C and 90 °C

TEMPERATURE SENSOR

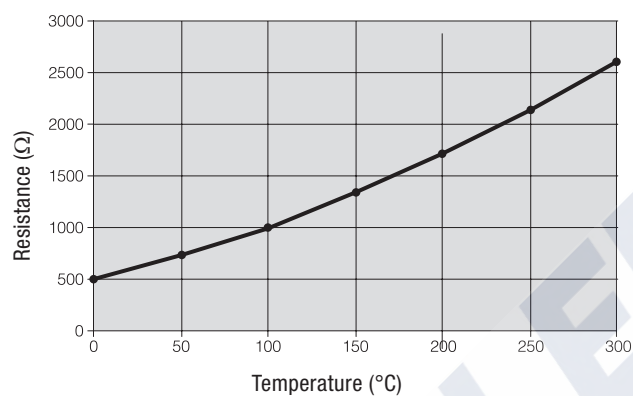

FLAME SENSOR

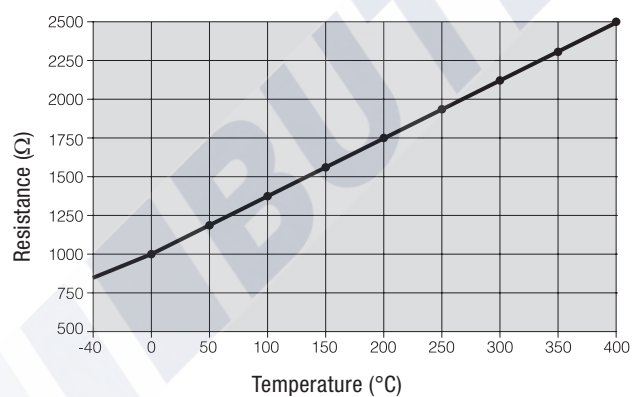

4 TROUBLESHOOTING

WHAT TO CHECK FIRST IN CASE OF FAULTS

▪ Check

- Fuel in the tank?
- Fuel lines leaking? (visual check)
- In the case of diesel heaters, summer diesel still in the fuel lines?
- Hot air system blocked?

In case of sooty combustion, check the following:

- Is anything clogging the combustion air supply or exhaust system?
⇒ Remove blockage.
- Metering pump pumping too much?
⇒ Measure fuel quantity (see [Page 27](#)), if applicable, replace metering pump.

▪ Electrical components

- Cables, connections damaged?
- Contacts corroded?
- Fuses defective?
- Incorrect wiring? (short circuit, interruption)

▪ Check battery voltage

- Battery voltage < 21 V, the undervoltage protection has triggered.

▪ Check voltage supply (Terminal 30)

Measure the applied voltage in connector A (see circuit diagram [Page 29](#)) between chamber 3 (cable 2.5² rt) and chamber 4 (cable 1.5² br).

If it differs from the battery voltage, check the fuses, the supply cables, the ground connection and the positive support point on the battery for voltage drop (corrosion / interruption).

▪ Check switch-on signal

Switch on the heater at the control unit. Check whether voltage is applied in connector B between chamber 9 (cable 1.5² ge) and connector A, chamber 4 (cable 1.5² br). If no voltage is applied, then check the supply cable (cable 1.5² ge), the 25 A miniature circuit breaker (item 2.7 in the circuit diagram) and the control unit (item 3.1.3 in the circuit diagram).

▪ Check control unit

Disconnect the connector at the control unit, install a jumper between the red 1.5² rt cable and the yellow 1.5² ge cable. If a voltage is measured between connector B, chamber 9 (cable 1.5² ge) and connector A, chamber 4 (cable 1.5² br), replace the control unit.

OVERVIEW OF TESTING EQUIPMENT

CALL UP DIAGNOSTIC SIGNALS

At the rear of the “Heat – Off – Ventilate” toggle switch (3.1.3), jumper terminal 1 (ge) and 2 (swws) with a cable bridge for 0.5 to 5 sec. or connect a switch (fault code query 3.1.12) as shown in the circuit diagram.

Alternatively, connection B9 can be jumpered directly at the control box, connector B.

Switch on the heater

The operating display light (3.4.1) flashes and outputs a diagnostic signal.

Diagnostic signal	Fault code	Fault
0 sec. 8 sec.	000	No fault
— — — — —	001	Early warning: Overvoltage / undervoltage
— — — — —	002	
— — — — —	010	Overvoltage cutout
— — — — —	011	Undervoltage cutout
— — — — —	020	Glow plug and ignition spark generator – interruption
— — — — —	029-033 036	Burner motor is defective, Short circuit in air solenoid valve relay
— — — — —	052	No start, Safety limit exceeded
— — — — —	012	Overheating Metering pump interruption
— — — — —	047	Short circuit in metering pump
— — — — —	060-063	Temperature sensor: Interruption, short circuit Setpoint potentiometer: Interruption, short circuit
— — — — —	064, 065	Flame sensor: Interruption, short circuit
— — — — —	056	Flame cutout in low stage
— — — — —	054	Flame cutout in high stage
— — — — —	090, 092-094	Control box defective
— — — — —	091	Fault due to external interference voltage (reset)

4 TROUBLESHOOTING

FAULT DIAGNOSIS USING THE DIAGNOSTIC UNIT

(Order No.: 22 1529 89 00 00)

The current fault is displayed as "AF" and a 2-digit number and is always written in memory location F1.

Preceding faults are moved to the memory locations F2 – F5, if necessary the content of memory position F5 is overwritten.

PLEASE NOTE!

- It is very important to always install in the given order.
- Not only the defective component, but also a defective current circuit results in a fault being displayed.
- Fault code, fault description, cause / remedial action are described from page 14.



- Delete fault memory
- Delete fault memory
- Switch heater On / Off, request diagnosis
- Reverse, F5 – F1
- Forward, F1 – F5, current fault (AF)

JE DIAGNOSTIC UNIT CONNECTION AT THE CONTROL BOX

(see following sketch)

- Lay a cable from the diagnostic unit (6 pin connector housing, chamber 3) to the control box (14 pin connector B, chamber 4, cable 1.5² blws) and connect.
- Lay a cable from the diagnostic unit (6 pin connector housing, chamber 5) to the control box (4 pin connector A, chamber 3, cable 2.5² rt) and connect.
- Lay a cable from the diagnostic unit (6 pin connector housing, chamber 1) to the control box (4 pin connector A, chamber 4, cable 1.5² br) and connect.

Display

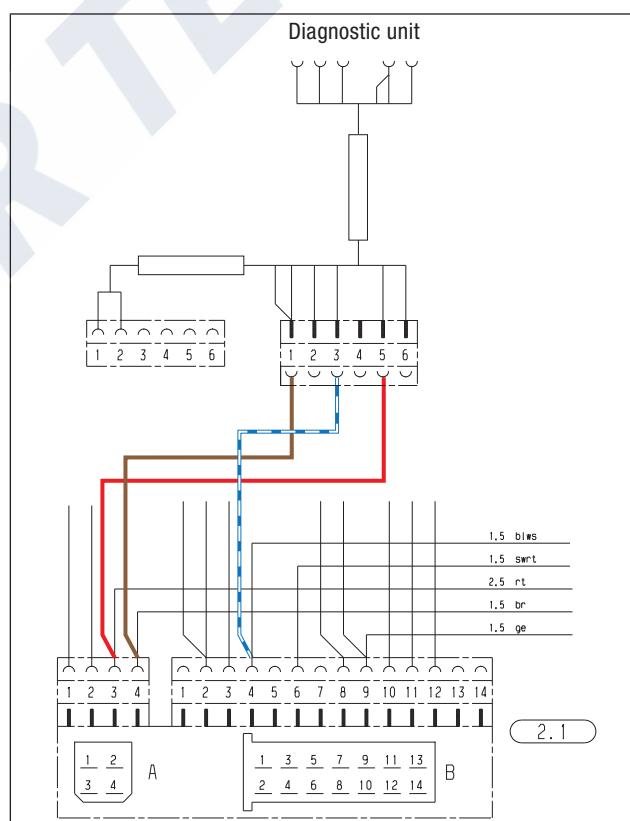

Connect the diagnostic unit at the control box 2.1 (connector A and B), for complete circuit diagram, see [Page 29](#).

4 TROUBLESHOOTING

QUERY THE FAULT MEMORY

- Use the **[D]** key to switch on the heater.

Display is as follows:

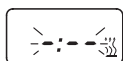

Heater has no malfunction

- After 8 sec the following is displayed:

Display is as follows:

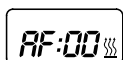

Heater has no malfunction

or

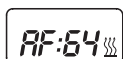

e.g. current fault / fault code 64

or

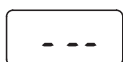

Fault diagnosis not possible

POSSIBLE CAUSES

- Adapter cable is not properly connected.
- Control box is defective or is not capable of diagnosing (not a universal control box).

DISPLAY OF THE FAULT MEMORY F1 – F5 OR F5 – F1

- Press the **[←]** or **[→]** button again, or press several times, to display the fault memory.

Display is as follows:

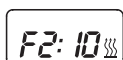

e.g. fault memory 2 / fault code 10

PLEASE NOTE!

Only the fault memory locations with an error assigned to them are displayed.

DELETE FAULT MEMORY

- Press both **[L]** buttons simultaneously until the following appears in the display:

Display is as follows:



- If the fault memory has been deleted the most recent current fault is displayed. The current fault is not reset to 00 until the heater is restarted – provided no new fault exists.

Display is as follows:

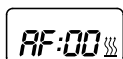

Heater has no malfunction

CANCEL THE CONTROL BOX LOCK

- Delete the fault memory as described and use the **[D]** button to switch off the heater.

- The control box lock is cancelled and the diagnosis closed.

Display is as follows:

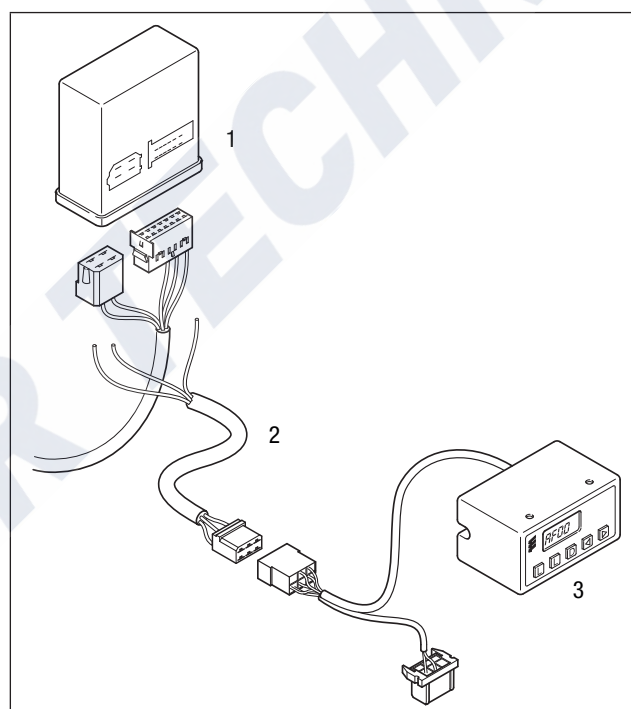
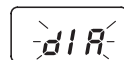

- Control box
- Cable loom (made yourself)
- Diagnostic unit

4 TROUBLESHOOTING

FAULT CODE DISPLAY	FAULT DESCRIPTION	COMMENTS ▪ REMEDIAL ACTION
000	No fault	— —
001	Early warning, overvoltage	Voltage between A3 and A4 at control box is higher than 28 V.
002	Early warning, undervoltage	Voltage between A3 and A4 at control box is lower than 22 V.
010	Overvoltage shutdown	Voltage between A3 and A4 at control box is higher than 29.4 V (voltage values must be applied for longer than 20 sec.). ▪ Check battery, controller and electrical supply leads.
011	Shutdown due to undervoltage (heater not functioning)	Voltage between A3 and A4 at control box is lower than 21 V (voltage values must be applied for longer than 20 sec.). ▪ Check battery, controller and electrical supply leads.
012	Overheating or metering pump interruption (B12)	▪ Check connection of control box B12 up to the metering pump for continuity. – Check overheating switch (switching value 70 °C and 90 °C). – Check hot air pipes for blockage, if necessary remove blockage.
020	Glow plug interruption	▪ Check glow plug, replace if necessary. ▪ Check connection of control box A1 up to the ignition spark generator and glow plug for continuity. PLEASE NOTE! Interruption in the glow coil alone is not detected due to ignition spark generator connected in parallel.
025	Diagnostic output short circuit (B4)	Check connection at control box B4 up to amplifier for short circuit to plus (positive pole).
029	Burner motor is defective	Speed difference for longer than 240 seconds:
032		Speed < 40 % compared to setpoint value (motor does not turn).
033		▪ Use analog voltmeter to measure voltage while blower is running. – If voltage is applied but motor is not running, the replace motor.
036	Air solenoid valve relay short circuit (B6)	Check connection of control box B6 up to the connection of relay 2.5.15. for short circuit. ▪ If ok ⇒ replace relay.
047	Short circuit in metering pump	▪ Check connection of control box B12 up to the metering pump for short circuit. ▪ Check metering pump, replace if necessary.
052	No start – safety time limit exceeded	▪ No flame detected within the start phase. Flame sensor value < 100 °C (1380 Ω). ▪ Check fuel supply and glow plug. ▪ Check exhaust and combustion air system. ▪ Check flame sensor, flame sensor values, see Page 10 .
054	Flame cutout in high stage	Heater has ignited (flame detected) and signals flame cutout during a power stage. Check fuel quantity, blower speed and fuel supply. ▪ Check exhaust and combustion air system, If combustion ok ⇒ check flame sensor, diagram of flame sensor values, see Page 10 .
056	Flame cutout in low stage	

4 TROUBLESHOOTING

FAULT CODE DISPLAY	FAULT DESCRIPTION	COMMENTS ▪ REMEDIAL ACTION
060 061	Temperature sensor interruption (B3) Temperature sensor short circuit (B3)	Temperature sensor signals temperature value outside the measuring range. ▪ Check connection cables: – Ohmic value between B2 and B3 > 3000 Ω (in case of interruption) – Ohmic value between B2 and B3 > 260 Ω (in case of short circuit) ▪ For diagram of temperature sensor values, see Page 10 .
062 063	Setpoint potentiometer interruption (B6) Setpoint potentiometer short circuit (B6)	Potentiometer of the control unit signals setpoint outside of the control range. ▪ Check connection cables: – Ohmic value between B2 and B3 > 3000 Ω (in case of interruption) – Ohmic value between B2 and B3 > 260 Ω (in case of short circuit) ▪ Normal values: 680 Ω – 1150 Ω.
064 065	Flame sensor interruption (B10) Flame sensor short circuit (B10)	Flame sensor signals temperature value outside the measurement range. ▪ Check connection cables: – Ohmic value between B2 and B3 > 3000 Ω (in case of interruption) – Ohmic value between B2 and B3 > 200 Ω (in case of short circuit) ▪ For diagram of flame sensor values, see Page 10 .
091	Fault due to external interference voltage (reset)	Control box fault due to interference voltages from the vehicle's electrical system. Possible causes: Poor battery, charger, other interference sources. ▪ Remove interference voltages.
090 092 093 094	Control box is defective (internal fault / reset) Control box is defective (ROM error) Control box is defective (RAM error) Control box is defective (EEPROM error)	Internal error found in the microprocessor / memory. ▪ Replace control box.
255	Control box fault memory deleted	The fault memory has been overwritten by external interference voltages. ▪ Remove interference voltages.

5 REPAIR INSTRUCTIONS

The permitted repair work to the heater is described in the "Repair Instructions" chapter. The heater must be removed from the vehicle for the repair work to be carried out.

The heater is assembled in the reverse order, note and follow any additional instructions.

PLEASE NOTE!

After completing all the work and installing the heater in the vehicle, perform a functional check on the heater.

SAFETY INSTRUCTIONS TO BE NOTED AND FOLLOWED BEFORE WORKING ON THE HEATER



DANGER!

RISK OF INJURY, BURNS AND POISONING!

- Always switch off the heater beforehand and leave it to cool.
- Disconnect the battery.
- The heater must not be operated in closed rooms such as garages or workshops.
Exception:
Exhaust suction available directly at the entry to the exhaust pipe.



CAUTION!

- The seals of dismantled components must be renewed.
- During repair work, check all components for damage and if necessary replace.
- Check connector contacts, plug-in connections and cables for corrosion and damage and if necessary repair.
- Only ever use Eberspächer spare parts if replacements are necessary.
- Operation or the after running of the heater may only be stopped in an emergency (see "EMERGENCY OFF" [Page 8](#)) by interrupting the battery current (risk of heater overheating).

PARTS LIST FOR ASSEMBLY DRAWING

- 1 Blower 24 V, complete
- 2 Impeller
- 3 Rotary distributor, complete
- 4 Rotary distributor
- 5 Coupling, complete
- 6 Heat exchanger
- 7 Lining
- 8 Insulation
- 9 Seal
- 10 Jacket, complete
- 11 Hood, d = ø 100 mm
- 12 Hood, d = ø 100 mm, complete
- 13 Box
- 14 Seal
- 15 Cover
- 16 Seal
- 17 Valve
- 18 Clip
- 19 Resistor, glow plug
- 20 Glow plug
- 21 Flame sensor
- 22 Clip
- 23 Overheating sensor
- 24 Temperature sensor
- 25 Ignition spark generator
- 26 Adapter bush
- 27 Ignition lead connector
- 28 Radio interference suppression capacitor, complete
- 29 Distribution strip
- 30 Lead harness
- 31 Seal
- 32 Lead harness
- 33 Lead
- 34 Lead harness
- 35 Bush housing
- 36 Lock nut
- 37 Grommet
- 38 Cover
- 39 Grommet
- 40 Sealing ring, exhaust pipe
- 41 Cover
- 42 Washer, A 4.3
- 43 Washer, A 5.3
- 44 Lock nut
- 45 Cable tie, 2.5 × 100 mm
- 78 Benzing retaining ring

5 REPAIR INSTRUCTIONS

ASSEMBLY DRAWING

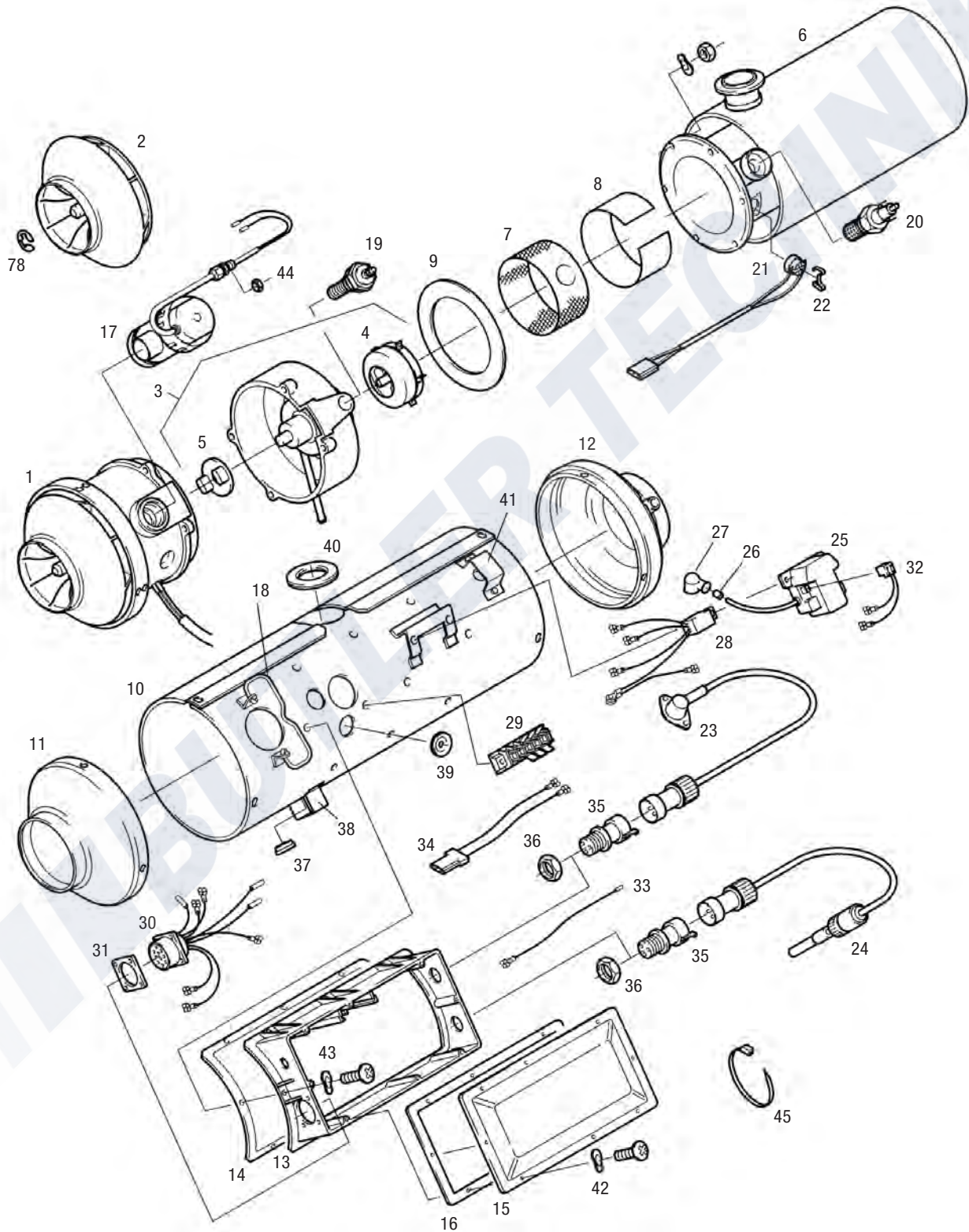

5 REPAIR INSTRUCTIONS

REPAIR STEPS

PLEASE NOTE!

This repair instruction describes how to dismantle the heater in individual repair steps. Reference is made to the necessary preceding steps to be performed at the relevant repair steps.

Repair step 1

Dismantle maintenance cover from protective casing [Page 19](#)

Repair step 2

Dismantle glow plug and check function [Page 19](#)

Repair step 3

Dismantle series resistor for glow plug [Page 20](#)

Repair step 4

Dismantle solenoid valve for combustion air [Page 20](#)

Repair step 5

Dismantle ignition spark generator [Page 21](#)

Repair step 6

Dismantle radio interference suppression capacitor [Page 22](#)

Repair step 7

Dismantle overheating switch [Page 22](#)

Repair step 8

Dismantle temperature sensor [Page 23](#)

Repair step 9

Dismantle outer jacket, hood and brackets [Page 23](#)

Repair step 10

Dismantle flame sensor [Page 24](#)

Repair step 11

Dismantle blower from heat exchanger [Page 25](#)

Repair step 12

Dismantle impeller [Page 25](#)

Repair step 13

Pull off coupling [Page 26](#)

Repair step 14

Dismantle rotary distributor [Page 26](#)

Repair step 15

Dismantle the combustion chamber lining [Page 26](#)

VIEW OF COMPLETE UNIT



5 REPAIR INSTRUCTIONS

DISMANTLE THE HEATER

REPAIR STEP 1

DISMANTLE MAINTENANCE COVER FROM PROTECTIVE CASING

- Unscrew the 8 fixing screws of the maintenance cover.
- Remove the maintenance cover.

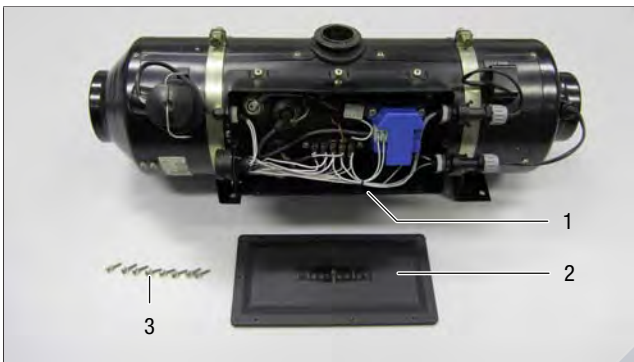

- 1 Protective casing
- 2 Maintenance cover
- 3 Fixing screws

PLEASE NOTE!

NOTES FOR THE ASSEMBLY:

Fixing screws tightening torque: 1.5+1 Nm

REPAIR STEP 2

DISMANTLE GLOW PLUG AND CHECK ITS FUNCTION

To dismantle the glow plug, complete [Repair step 1](#) first.

- Pull the spark plug connector and cable from the glow plug.
- Unscrew the glow plug with a ring spanner or spark plug socket.



- 1 Spark plug connector with cable

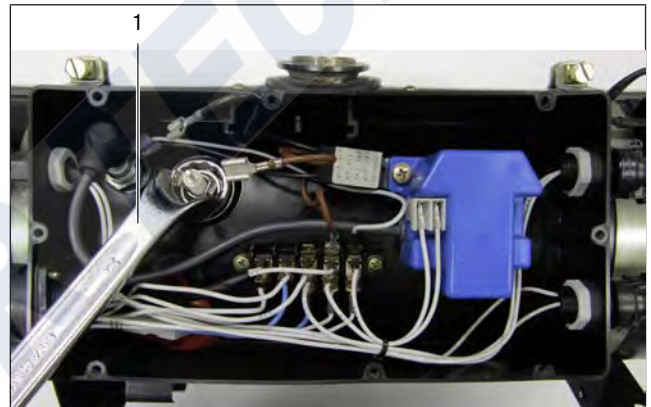

- 1 Ring spanner

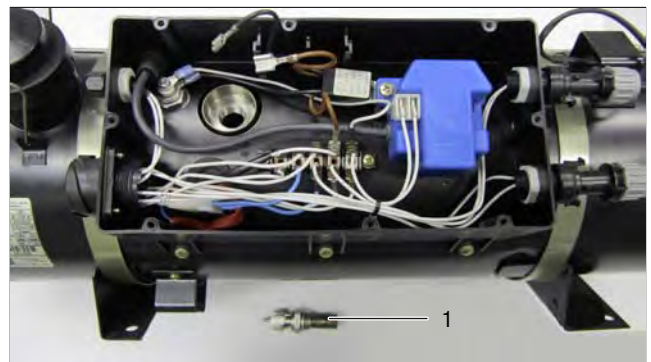

- 1 Glow plug

PLEASE NOTE!

NOTES FOR THE ASSEMBLY:

Glow plug tightening torque: 17+2 Nm

5 REPAIR INSTRUCTIONS

REPAIR STEP 3

DISMANTLE SERIES RESISTOR FOR GLOW PLUG

To dismantle the series resistor, complete [Repair step 1](#) first.

- Use socket spanner to undo hexagon nut and remove connector.

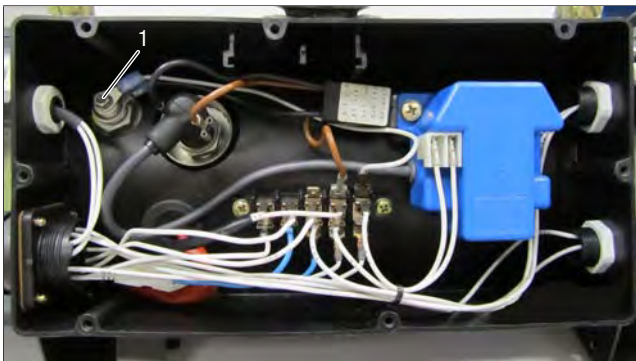

1 Hexagon nut with U washer



1 Socket spanner

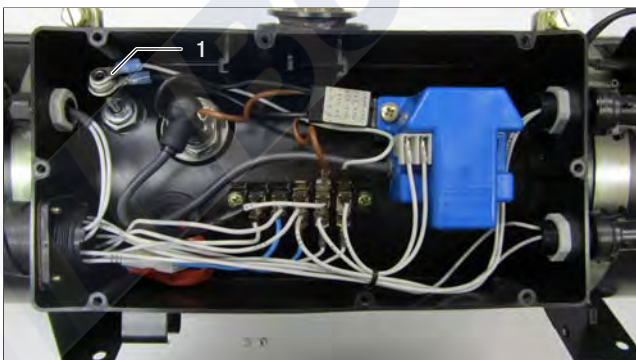

1 Connector

- Unscrew series resistor.



1 Socket spanner for series resistor

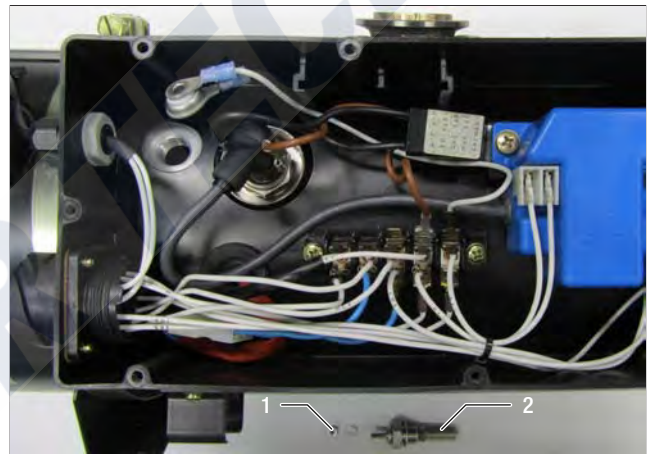

1 Hexagon nut with U washer
2 Series resistor

PLEASE NOTE!

NOTES FOR THE ASSEMBLY:

Series resistor tightening torque: 17+2 Nm

5 REPAIR INSTRUCTIONS

REPAIR STEP 4

DISMANTLE SOLENOID VALVE FOR COMBUSTION AIR

To dismantle the solenoid valve for combustion air, complete [Repair step 1](#) first.

- Dismantle combustion air hose from solenoid valve.
- Unclip electric leads of the solenoid valve from the round, 16 pin connector.
- Unlock clip from solenoid valve and pull out solenoid valve.
- Pull lead harness out of the protective casing.

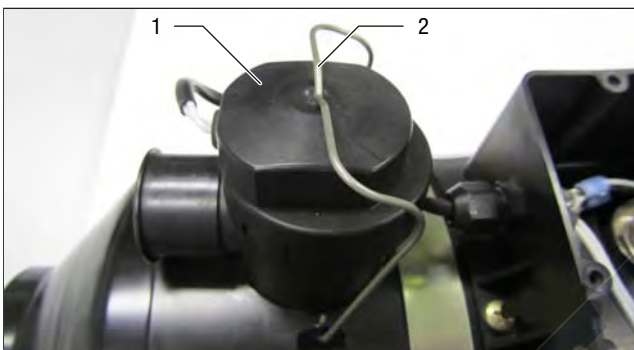

- 1 Solenoid valve
- 2 Clip



- 1 Clip, unlocked

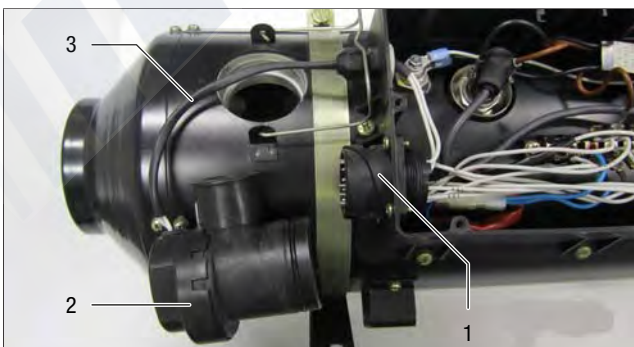

- 1 16-pin connector, round
- 2 Solenoid valve
- 3 Cable loom, solenoid valve

REPAIR STEP 5

DISMANTLE IGNITION SPARK GENERATOR

To dismantle the ignition spark generator, complete [Repair step 1](#) first.

- Label electric leads and plug-in connections and disconnect.
- Disconnect the 2-pin connector at the ignition spark generator.
- Pull the spark plug connector from the ignition spark generator at the glow plug.
- Unscrew two Phillip's screws and pull off ignition spark generator.



- 1 Ignition spark generator

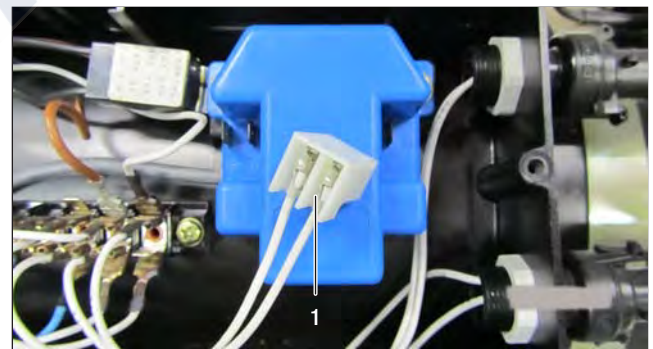

- 1 2-pin connector

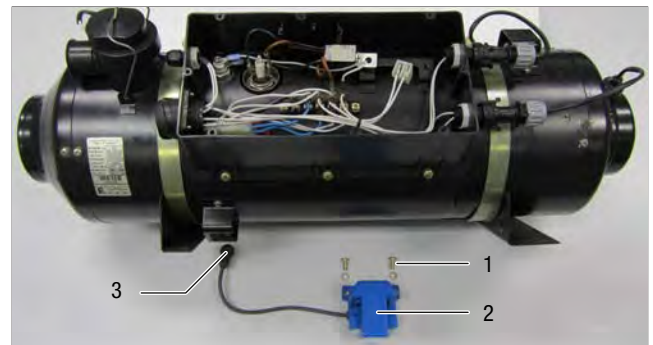

- 1 Phillip's screws
- 2 Ignition spark generator
- 3 Spark plug connector

5 REPAIR INSTRUCTIONS

REPAIR STEP 6

DISMANTLE RADIO INTERFERENCE SUPPRESSION CAPACITOR

To dismantle the radio interference suppression capacitor, complete [Repair step 1](#) first.

- Unscrew the two Phillip's screws at the ignition spark generator.
- Use socket spanner to undo hexagon nut from the series resistor and remove connector.
- Remove the radio interference suppression capacitor.

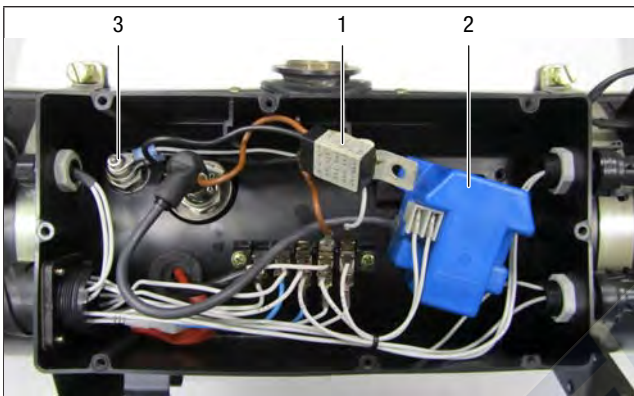

- 1 Radio interference suppression capacitor
- 2 Ignition spark generator
- 3 Hexagon nut, series resistor

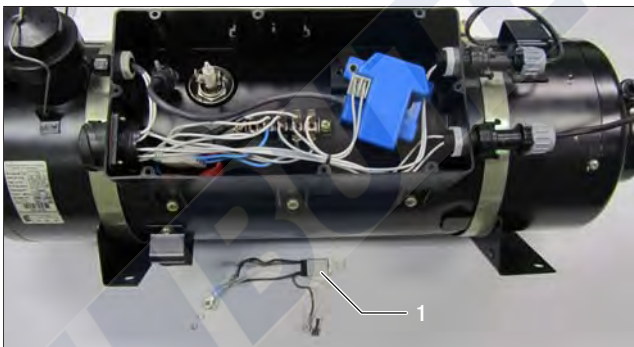

- 1 Radio interference suppression capacitor with electric connections

REPAIR STEP 7

DISMANTLE THE OVERHEATING SWITCH

- Disconnect the connector from the overheating switch at the protective casing

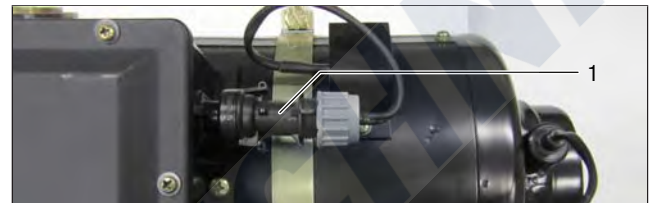

- 1 Connector, overheating switch

- Undo two Phillip's screws from the protective bracket of the overheating switch and remove the protective bracket.



- 1 Protective bracket, overheating switch

- Undo two Phillip's screws from the overheating switch and remove the overheating switch.

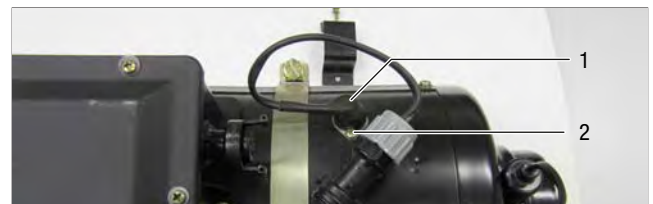

- 1 Overheating switch
- 2 Fixing screws, overheating switch (Phillip's screws)

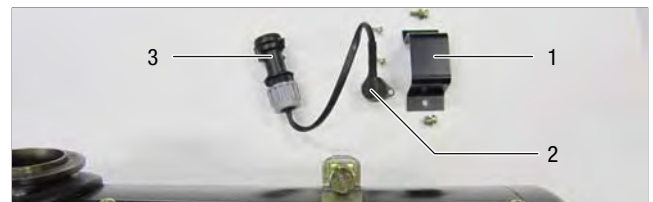

- 1 Protective bracket, overheating switch
- 2 Overheating switch
- 3 Connector, overheating switch

PLEASE NOTE!

NOTES FOR THE ASSEMBLY:

Tightening torque, fixing screws, protective bracket: 1.4+10 % Nm

5 REPAIR INSTRUCTIONS

REPAIR STEP 8

DISMANTLE TEMPERATURE SENSOR

- Disconnect the connector from the temperature sensor at the protective casing.

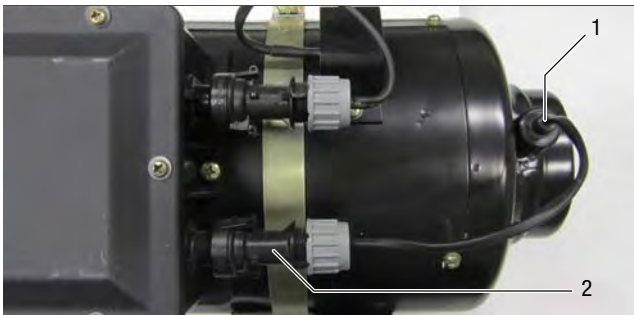

- 1 Temperature sensor
- 2 Connector, temperature sensor

- Push back protective cap and unscrew union nut on temperature sensor.



- 1 Protective cap
- 2 Union nut

- Pull out temperature sensor and remove with cable loom.



- 1 Temperature sensor with cable loom

PLEASE NOTE!

NOTES FOR THE ASSEMBLY:

Ensure the temperature sensor sits correctly in the guide groove.

REPAIR STEP 9

DISMANTLE OUTER JACKET, HOOD AND BRACKETS

To dismantle the outer jacket, complete [Repair step 1 – 8](#) first.

- Dismantle protective casing

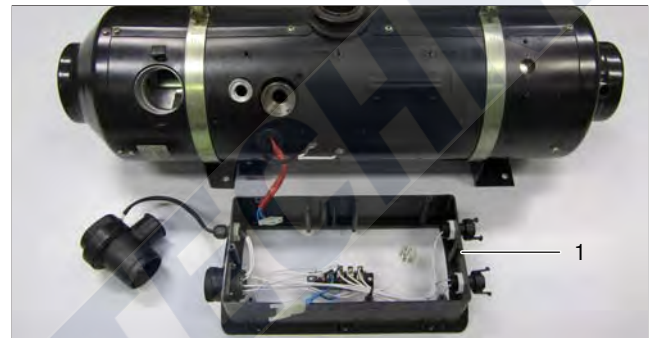

- 1 Protective casing dismantled

- Dismantle rubber grommet for electric lead to the electric motor and flame sensor, push electric leads back through the opening in the outer jacket.

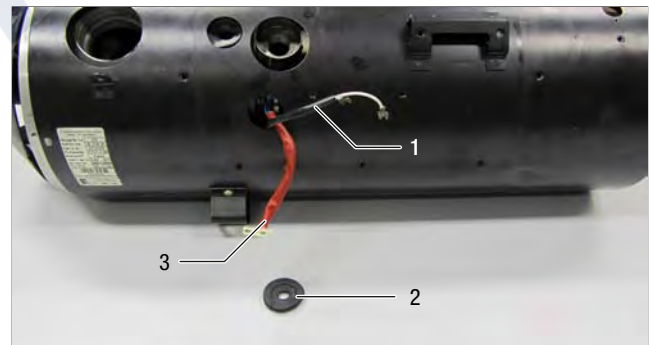

- 1 Connection leads, electric motor
- 2 Rubber grommet
- 3 Connection leads, flame sensor

5 REPAIR INSTRUCTIONS

REPAIR STEP 9

DISMANTLE OUTER JACKET, HOOD AND BRACKETS

- Dismantle protective bracket from fuel connection.
- Remove rubber grommet, fuel connection.

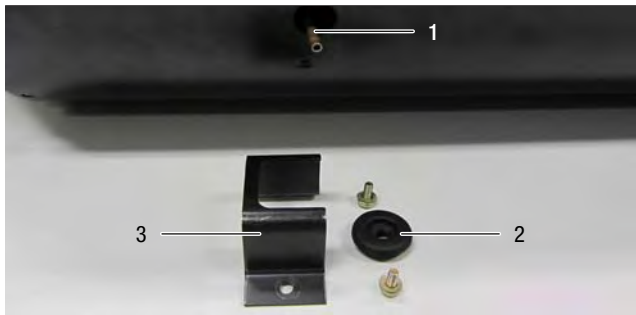

- 1 Fuel connection
- 2 Rubber grommet
- 3 Protective bracket

- Dismantle outlet hood and brackets.

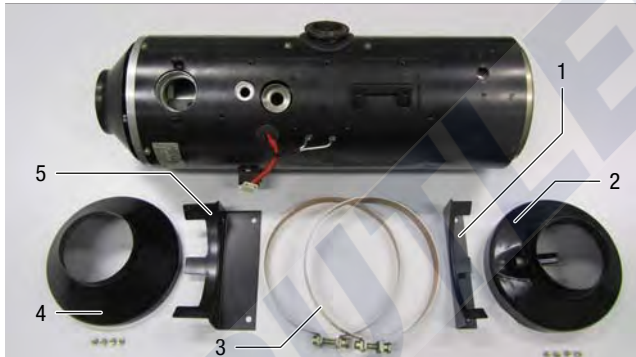

- 1 Bracket, right-hand side
- 2 Outlet hood
- 3 Clips
- 4 Inlet hood
- 5 Bracket, left-hand side

- Unscrew the five fixing screws of the outer jacket at the carrier and at the jacket overlap.
- Carefully place the basic unit on the inlet hood.
- Bend up outer jacket by approx. 70 mm and remove.
- Dismantle the inlet hood.



- 1 Outer jacket, dismantled

PLEASE NOTE!

NOTES FOR THE ASSEMBLY:

Check rubber grommet for exhaust pipe, if necessary renew.

Tightening torque, fixing screws, protective bracket: 1.4+10 % Nm

Tightening torque, fixing screws, jacket: 1.4+10 % Nm

REPAIR STEP 10

DISMANTLE FLAME SENSOR

To dismantle the flame sensor, complete [Repair step 1 – 9](#) first.

- Remove fixing clip and remove flame sensor.

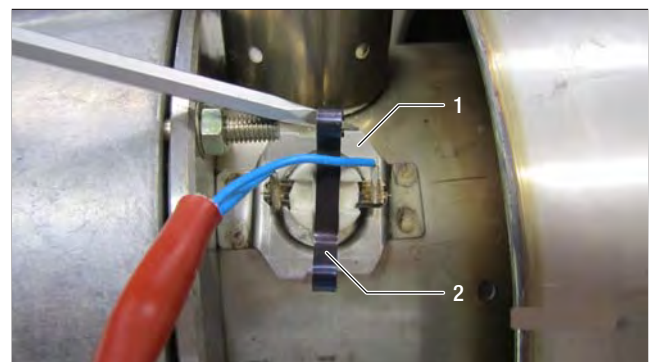

- 1 Flame sensor
- 2 Fixing clip

5 REPAIR INSTRUCTIONS

REPAIR STEP 11

DISMANTLE BLOWER FROM HEAT EXCHANGER

To dismantle the blower from the heat exchanger, complete [Repair step 1–9](#) first.

- Undo hexagon nuts and spring lock washers.
- Remove blower from heat exchanger.
- Remove seal and clean sealing surface.

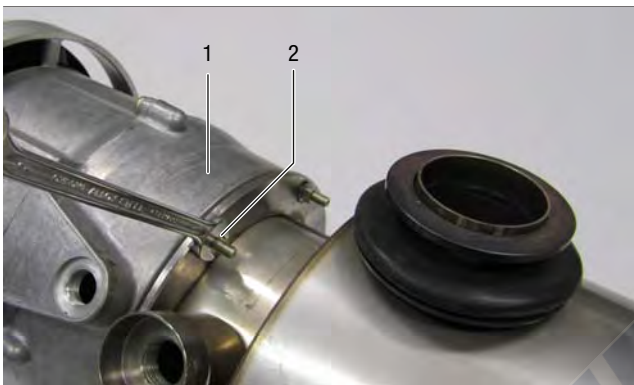

- 1 Blower
- 2 Hexagon nut with spring lock washer

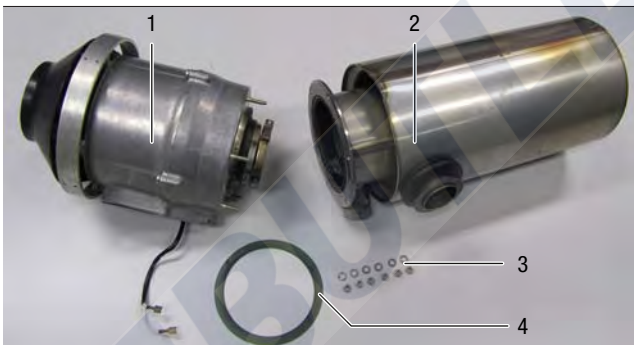

- 1 Blower
- 2 Heat exchanger
- 3 Hexagon nut / spring lock washers
- 4 Seal

PLEASE NOTE!

NOTES FOR THE ASSEMBLY:

Renew seal and spring lock washers.

Tightening torque, hexagon nuts: 5.6+0.6 Nm

REPAIR STEP 12

DISMANTLE IMPELLER

- Unscrew the fixing screws of the inlet hood and remove inlet hood.
- Pull (Benzing) retaining ring from the blower shaft and remove impeller.

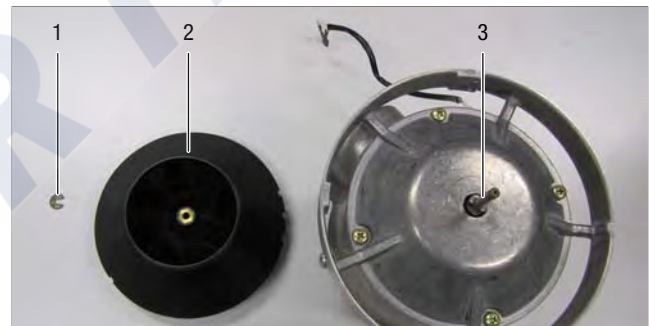
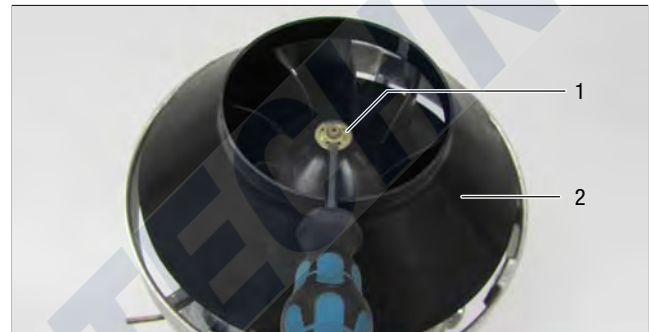

- 1 (Benzing) retaining ring
- 2 Impeller
- 3 Blower shaft

⚠ IMPORTANT!

Renew (Benzing) retaining ring for the impeller.

PLEASE NOTE!

NOTES FOR THE ASSEMBLY:

After installing the impeller, check it for free running.

5 REPAIR INSTRUCTIONS

REPAIR STEP 13

PULL OFF COUPLING

To pull off the coupling, complete [Repair step 1 – 9](#) and [Repair step 11](#) first.

- Undo 4 Phillip's screws from the rotary distributor housing.
- Remove rotary distributor housing from the blower.
- Pull coupling off the shaft.

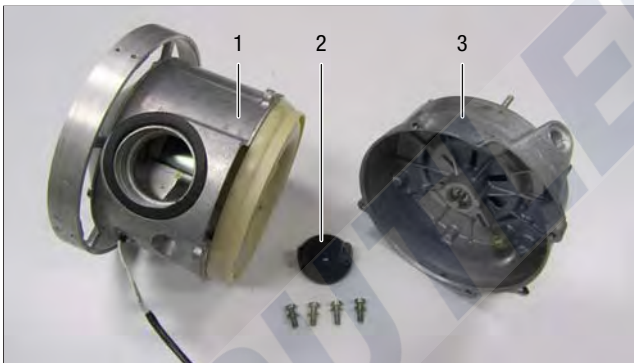
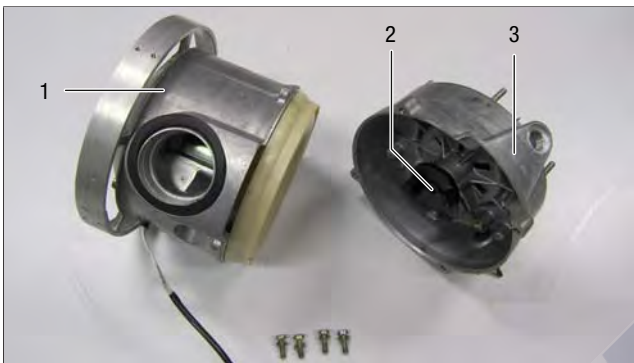

- 1 Blower
- 2 Coupling
- 3 Rotary distributor housing

PLEASE NOTE!

NOTES FOR THE ASSEMBLY:

Tightening torque, Phillip's screws: 2.8+10 % Nm

REPAIR STEP 14

DISMANTLE ROTARY DISTRIBUTOR

To dismantle the rotary distributor, complete [Repair step 1 – 9](#) and [Repair step 11](#) first.

- Unscrew rotary distributor from shaft.

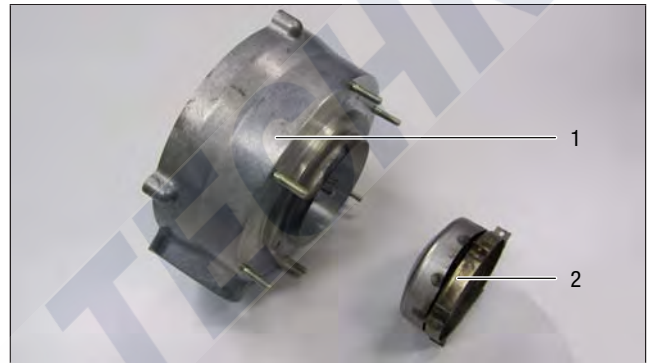

- 1 Rotary distributor housing
- 2 Rotary distributor

REPAIR STEP 15

DISMANTLE COMBUSTION CHAMBER LINING

To dismantle the combustion chamber lining, complete [Repair step 1 – 11](#) first.

- Use a screw driver to pull the combustion chamber lining out of the heat exchanger.



- 1 Heat exchanger
- 2 Combustion chamber
- 3 Combustion chamber lining

5 REPAIR INSTRUCTIONS

CHECK FUEL SUPPLY

Before measuring the fuel quantity, check the following points in the fuel supply.

- Check the screen in the metering pump.
- Check the laying of the fuel lines.
- Check fuel lines for leaks.
- Check and tighten the hose connections.
- Is the fuel removal installed according to the details in the technical description?

MEASURING THE FUEL QUANTITY

For a precise fuel measurement, at least 22 V, maximum 26 V should be applied to the control box.

PREPARING FOR THE MEASUREMENT

- Disconnect fuel line from the heater and discharge into a measuring cylinder.
- Connect voltmeter to the lead of connector A of the control box terminal 3 (+) and terminal 4 (-).
- Switch on heater. If the fuel is uniformly pumped (begins approx. 25 – 55 sec after being switched on), the fuel line is full and vented.
- Switch off heater and empty measuring cylinder.

MEASUREMENT

- Switch on heater.
- The fuel begins to be pumped approx. 25 – 55 sec after switching on the heater.
- During the measurement, hold the measuring cylinder at the level of the glow plug.
- Read off electrical voltage at the voltmeter.
- After approx. 90 sec of the fuel being pumped it is automatically switched off.
- Switch off the heater.
- Read off the quantity of fuel in the measuring cylinder.

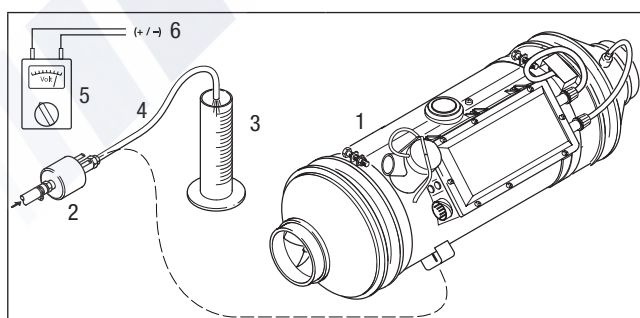

- | | |
|------------------------------|---------------------------------|
| 1 Heater | 4 Fuel line |
| 2 Metering pump | 5 Voltmeter |
| 3 Measuring cylinder (25 ml) | 6 Connection at the control box |

EVALUATION

- Transfer the measured fuel quantity into the diagram.
- The fuel consumption is ok, if the intersection of both values lies within the boundary curve.
- If the intersecting point is located outside, the fuel pump must be replaced.

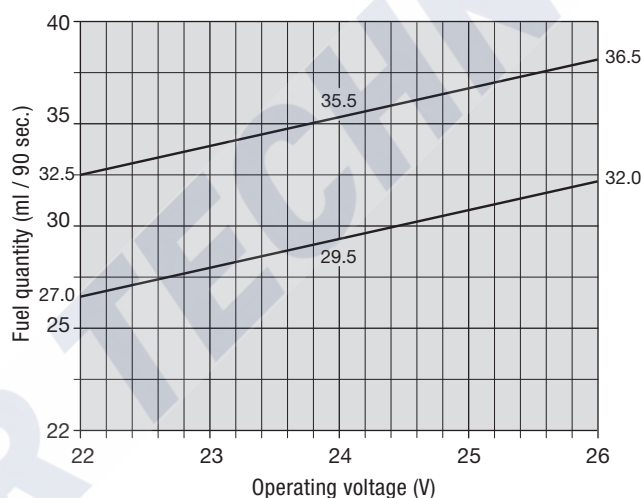

6 CIRCUIT DIAGRAM

PARTS LIST FOR CIRCUIT DIAGRAM, HEATER

- 1.1 Burner motor
- 1.2 Glow plug
- 1.2.1 Resistor for glow plug
- 1.3 Ignition spark generator
- 1.5 Overheating switch
- 1.7 Distribution strip
- 1.8.2 Radio interference suppression capacitor
- 1.8.3 Interference suppression filter
- 1.12 Flame sensor
- 1.13 Temperature sensor
- 2.1 Control box
- 2.2 Metering pump
- 2.3 Air solenoid valve (for combustion air)
- 2.5.15 Relay for air solenoid valve
- 2.7 Miniature circuit breaker, 25 A
- 2.15.7 Amplifier
- 3.1.3 Switch: Heat -Off-Ventilate
- 3.1.12 Fault code query
- 3.3.3 Temperature controller
- 3.4.1 Operating display

PLEASE NOTE!

For circuit diagram, see [Page 29](#).

CABLE COLOURS

rt	red	gn	green
bl	blue	ge	yellow
ws	white	vi	violet
sw	black	br	brown

Connector and bush housings are shown from the cable inlet side.

6 CIRCUIT DIAGRAM

HEATER CIRCUIT DIAGRAM

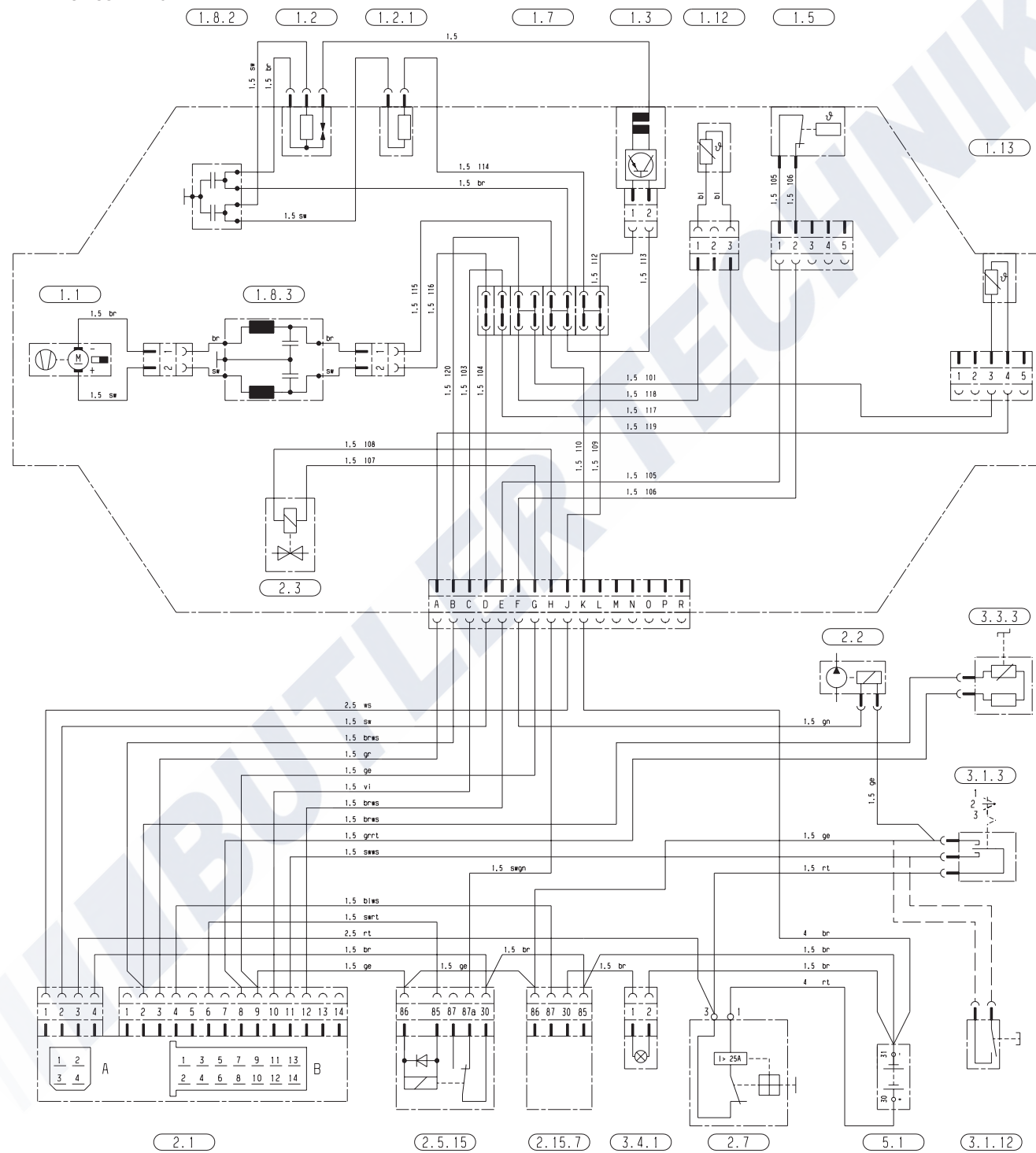

25 1728 00 96 02 B

For parts list, see [Page 28](#)

7 SERVICE

CERTIFICATIONS

The high quality of Eberspächer's products is the key to our success. To guarantee this quality, we have organised all work processes in the company along the lines of quality management (QM). Even so, we still pursue a large number of activities for continuous improvement of product quality in order to keep pace with the similarly constantly growing requirements made by our customers.

All the steps necessary for quality assurance are stipulated in international standards.

This quality is to be considered in a total sense. It affects products, procedures and customer / supplier relationships.

Officially approved public experts assess the system and the corresponding certification company awards a certificate.

Eberspächer has already qualified for the following standards:

QUALITY MANAGEMENT IN ACCORDANCE WITH DIN EN ISO 9001:2000 AND ISO/TS 16949:1999

ENVIRONMENTAL MANAGEMENT SYSTEM IN ACCORDANCE WITH DIN EN ISO 14001:1996

DISPOSAL

DISPOSAL OF MATERIALS

Old devices, defect components and packaging material can all be separated and sorted into pure-grade factions so that all parts can be disposed of as required in an environment-friendly manner recycled where applicable.

Electric motors, control boxes and sensors (e.g. temperature sensors) are deemed to be "electronic scrap".

DISMANTLING THE HEATER

The heater is dismantled according to the repair stages in the current troubleshooting / repair instructions.

PACKAGING

The packaging of the heater can be kept in case it has to be sent back.

EC DECLARATION OF CONFORMITY

With regard to the product named in the following

HEATER TYPE V 7 S

we herewith confirm that it conforms with the prime safety requirements stipulated in the directives of the EU Council for harmonisation of the legal regulations of the member states with regard to electromagnetic compatibility (89 / 336 / EEC).

This declaration applies to all heaters produced according to the V 7 S production drawings – which are an integral part of this declaration.

The following standards / directives have been used to assess the product with regard to electromagnetic compatibility:

- EN 50081 – 1 Basic form interference emission
- EN 50082 – 1 Basic form of interference immunity
- 72 / 245 / EEC – Modification status 2006 / 96 / EC Interference suppression in motor vehicles.

7 SERVICE

LIST OF ABBREVIATIONS

ABG

General type approval

ADR

European agreement about the international transport of dangerous goods on the road (ADR).

EMC

Electromagnetic compatibility

JE SERVICE PARTNER

J. Eberspächer service partner

FAME

Biodiesel to EN 14214.

STVZO

Straßenverkehrs-Zulassungs-Ordnung (German road traffic licensing regulations)

A

Current intensity in ampere

V

Voltage in volt

W

Power in watt

BUTLER TECHNİK

Headquarters:

J. Eberspächer GmbH & Co. KG
Eberspächerstraße 24
73730 Esslingen
Hotline: 0800 1234300
Fax hotline: 01805 262624
info@eberspaecher.com
www.eberspaecher.com

