

Hydronic M-II Boat Water Heating Kit

Installation and Operating Instructions



Eberspächer

Hydronic MII, 10, 12

25 2434 05 00 00 (12V)

25 2435 05 00 00 (24V)

25 2472 05 00 00 (12V)

25 2473 05 00 00 (24V)

Eberspächer (UK) Ltd.
Headlands Business Park,
Salisbury Road, Ringwood,
Hants BH24 3PB

www.eberspacher.com



BUTLER TECHNIK



Contents

1	Introduction	5	Electrical System
2	Operation and Function	6	Commissioning System
3	Product Information	7	Service and Maintenance
4	Installation	8	Notes

BUTLER TECHNIK

1 Introduction

Introduction

The Hydronic MII, 10/12 water heating unit is designed for boats, requiring general area heating and calorifier heating up to a maximum system requirement of 9.5kW / 12kW.

Before starting the installation, please read these instructions carefully since errors on installation can cause serious damage to the equipment or reduce its designed operating efficiency.

Please Note!

Any deviation or proposed changes must be cleared by one of the Distributors listed under the Service Maintenance Section.

Technical Description

The Marine Central Heating Kit is based on the Eberspächer Hydronic MII, 10/12 diesel fired water heaters.

The unit burns diesel in a sealed combustion chamber surrounded by a jacket of water which collects the heat from the walls of the heat exchanger. Thus heated water is then circulated by means of an internal pump through the associated pipework to the fan matrix. Combustion air for the burning process is drawn from the exterior or engine room if well ventilated by means of an integral blower unit. This combustion air is mixed with the diesel fuel which is conveyed from the bilge or wing fuel tanks by a fuel metering pump supplied with the kit. The combustible mixture of diesel and air is ignited by the unit's glow pin to establish a flame. The products of combustion pass through the flexible stainless steel exhaust and hull skin fitting to atmosphere. Both the stainless exhaust and hull fitting are included in the kit. The system is an indirect burner unit for delivering heated water to the cabins matrix and associated equipment.

Operation

To switch the heater on press and release the right hand heat key .

The symbol will be shown and the display will illuminate.

To switch the heater off press and release the heat key  once more.

When switched on, the combustion air blower and water pump start up and the glow plug comes into operation. A period of approximately 60 seconds allows the glow pin to reach temperature and then the fuel metering pump starts to pump fuel into the combustion chamber. The fuel and combustion air mixture is ignited and a flame is established. Once a stable flame has been established the flame sensor signals the control box to switch off the glow plug. The heater will then operate at full heating capacity.

Please Note!

If for any reason the heater fails to ignite within 105 seconds of the fuel being pumped, repeat the starting procedure no more than twice.

With the heater now working at full heating capacity the water is being circulated round the water jacket to the heater and associated pipework by the integral water pump.

As the circulated water (coolant) temperature increases, the heater will regulate from high to medium heat. Should the temperature continue to rise the heater will switch to its low heat setting.



1 Introduction

Special text structure, presentation and picture symbols

This manual uses special text structures and picture symbols to emphasise different contents. Please refer to the examples below for the corresponding meanings and associated actions.

Special structure and presentations

A dot (•) indicates a list which is started by a heading. If an indented dash (–) follows a dot, this list is subordinate to the dot.

Picture symbols



Regulation!

This picture symbol with the remark “Regulation” refers to a statutory regulation. Failure to comply with this regulation results in expiry of the type permit for the heater and preclusion of any guarantee and liability claims on J. Eberspächer GmbH & Co. KG.



Danger!

This picture symbol with the remark “Danger!” refers to the risk of a fatal danger to life and limb. Under certain circumstances, failure to comply with these instructions can result in severe or life-threatening injuries.



Caution!

This picture symbol with the remark “Caution!” refers to a dangerous situation for a person and/or the product. Failure to comply with these instructions can result in injuries to people and / or damage to machinery.

Please note!

These remarks contain application recommendations and useful tips for installation of the heater.

Important information before starting work

Range of application of the heater

The water heater operating independently of an engine is intended for installation in the following vehicles, depending on its heating output:

- Vehicles of all kinds
- Construction machinery
- Agricultural machinery
- Boats, ships and yachts

Please note!

- Installation of the heater is permitted in vehicles used for the transport of dangerous goods as per ADR.
- The heater is not approved for installation in vehicle compartments used by persons (more than 8 passenger spaces) in Class M₂ and M₃ vehicles (vehicles for the transport of passengers / commercial buses).
- The heater is not approved for installation in the driver or passenger compartments of Class M₁ vehicles (vehicles for the transport of passengers / cars) and Class N vehicles (vehicles for the transport of goods).

On account of its functional purpose, the heater is **not** permitted for the following applications:

- Long-term continuous operation, e.g. for pre-heating and heating of:
 - Residential rooms
 - Garages
 - Work huts, weekend homes and hunting huts
 - Houseboats, etc.



Caution!

Safety instructions for application and proper purpose

The heater must only be used and operated for the range of application stated by the manufacturer in compliance with the “Operating instructions” included with every heater.

Introduction

Statutory regulations

The Federal Road Transport Directorate has issued an “EC type approval“ and an “EMC type approval“ for the heater for installation in motor vehicles and with the following official type approval marks, noted on the heater name plate.

Hydronic M-II EG-e100 0215
 EMV-e1 035075



Regulation!

Directive 2001 / 56 / EU of the European Parliament and the Council

• Arrangement of the heater

- Parts of the structure and other components near the heater must be protected from excess heat exposure and possible contamination from fuel or oil.
- The heater must not pose a fire hazard even when it overheats.
This requirement is deemed to be fulfilled when adequate clearance to all parts is observed during installation, sufficient ventilation is provided and fire-proof materials or heat plates are used.
- The heater may not be mounted in the passenger compartment of Class M₂ and M₃ vehicles.
A unit may however be used in a hermetically sealed housing which also corresponds to the conditions stated above.
- The factory nameplate or duplicate must be affixed so that it can still be easily read when the heater is installed in the vehicle.
- All appropriate precautions must be taken when arranging the heater to minimise the risk of injuries to persons or damage to other property.

• Fuel supply

- The fuel intake connection must not be located in the passenger compartment and must be sealed with a properly closing lid to prevent any fuel leaks.
- In heaters for liquid fuel where the heater fuel is separate from the vehicle fuel, the type of fuel and intake connection must be clearly identified.
- A warning sign is to be fixed to the intake connection indicating that the heater must be switched off before refuelling.

• Exhaust system

- The exhaust outlet must be arranged so as to prevent any penetration of exhaust fumes into the vehicle interior through the ventilation system, warm air intakes or open windows.

• Combustion air intake

- The air for the heater combustion chamber must not be sucked in from the passenger compartment of the vehicle.
- The air intake must be arranged or protected in such a way that it cannot be blocked by other objects.

• Operating status display

- A clearly visible operating display in the user's field of vision must indicate when the heater is switched on and off.



1 Introduction



Regulations

Additional regulations for certain vehicles named in Directive 94 / 55 / EC (ADR Framework Directive)

Scope

This appendix applies to vehicles for which the special provisions of Directive 94 / 55 / EC apply to combustion heaters and their installation.

Definition of terms used

For the purposes of this appendix, the vehicle designations „EX / II“, „EX / III“, „AT“, „FL“ and „OX“ according to Chapter 9.1 of Annex B of Directive 94 / 55 / EC are used.

Technical regulations

General provisions (EX / II, EX / III, AT, FL and OX vehicles)

Avoid heating and ignition

The combustion heaters and their exhaust gas routing shall be designed, located, protected or covered so as to prevent any unacceptable risk of heating or ignition of the load. This requirement shall be considered as fulfilled if the fuel tank and the exhaust system of the appliance conform to provisions in 3.1.1.1 and 3.1.1.2. Compliance with these regulations shall be checked in the complete vehicle.

Fuel tanks

Fuel tanks for supplying the heater shall conform to the following regulations:

- In the event of any leakage, the fuel shall drain to the ground without coming into contact with hot parts of the vehicle or the load;
- fuel tanks containing petrol shall be equipped with an effective flame trap at the filler opening or with a closure enabling the opening to be kept hermetically sealed.

Exhaust system and exhaust pipe layout

The exhaust system as well as the exhaust pipes shall laid out or protected to avoid any danger to the load through heating or ignition. Parts of the exhaust system situated directly below the fuel tank (diesel) shall have a clearance of at least 100 mm or be protected by a thermal shield.

Switching on the combustion heater

The combustion heater may only be switched on manually. Automatic switching on via a programmable switch is not permitted.

EX / II and EX / III vehicles

Combustion heaters for gaseous fuels are not permitted.

FL vehicles

Combustion heaters must be able to be taken out of service/disabled at least by the methods described in the following:

- a) Switching off manually in the driver's cabin
- b) Switching off the vehicle's engine; in this case the heater may be manually switched back on by the vehicle driver;
- c) Starting up of a feed pump installed in the vehicle for the dangerous goods carried.

Combustion heater after-run

After-running of the switched off combustion heater is permitted. In the cases named in the „FL vehicles“ paragraph under letters b) and c) the supply of combustion air must be interrupted by suitable means after a maximum after-run period of 40 seconds. Only combustion heaters whose heat exchangers are verifiably not damaged by the reduced after-run period of 40 seconds beyond their usual use period may be used.

Please note!

- Compliance with the statutory regulations, the additional regulations and safety instructions is prerequisite for guarantee and liability claims. Failure to comply with the statutory regulations and safety instructions and incorrect repairs even when using original spare parts make the guarantee null and void and preclude any liability for J. Eberspächer GmbH & Co. KG.
- Subsequent installation of this heater must comply with these installation instructions.
- The statutory regulations are binding and must also be observed in countries which do not have any special regulations.
- When the heater is to be installed in vehicles not subject to the German Ordinance for the Registration of Motor Vehicles (StVZO), for example ships, the specially valid regulations and installation instructions for these special applications must be observed.
- Installation of the heater in special vehicles must comply with the regulations applying to such vehicles.
- Other installation requirements are contained in the corresponding sections of this manual.

Introduction

Safety instructions for installation and operation



Danger!

Risk of injury, fire and poisoning

- Disconnect the vehicle battery before starting any kind of work.
- Before working on the heater, switch the heater off and let all hot components cool down.
- The heater must not be operated in enclosed rooms, e.g. in the garage or multi-storey car park.



Caution!

Safety instructions for installation and operation

- The heater must only be installed by a JE partner authorised by the manufacturer according to the instructions in this manual and possibly according to special installation recommendations; the same applies to any repairs to be carried out in the case of repairs or guarantee claims.
- Repairs by non-authorised third-parties or with not original spare parts are dangerous and therefore not allowed. They result in expiry of the type permit of the heater; consequently, when installed in motor vehicles they can cause expiry of the vehicle operating licence.
- The following measures are not allowed:
 - Changes to components relevant to the heater.
 - Use of third-party components not approved by J. Eberspächer GmbH & Co. KG.
 - Nonconformities in installation or operation from the statutory regulations, safety instructions or specifications relevant to safe operation as stated in the installation instructions and operating instructions. This applies in particular to the electrical wiring, fuel supply, combustion air system and exhaust system.
- Only original accessories and original spare parts must be used during installation or repairs.
- Only original accessories and spare parts may be used for installation or repairs.
- Only the controls approved by Eberspächer may be used to operate the heater. The use of other controls can result in malfunctions.
- Before the heater is installed again in another vehicle, rinse the heater parts carrying water with clear water.
- When carrying out electric welding on the vehicle, the plus pole cable at the battery should be disconnected and placed at ground to protect the controller.

- The heater must not be operated where there is a risk of an accumulation of flammable vapours or dust, for example close to
 - fuel depot
 - coal depot
 - wood depot
 - grain depots etc.
- The heater must be switched off when refuelling.
- When the heater is mounted in a safety housing etc., the installation compartment of the heater is not a stowage compartment and must be kept clear. In particular fuel canisters, oil cans, spray cans, gas cartridges, fire extinguishers, cleaning rags, items of clothing, paper etc. must not be stored or transported on or next to the heater.
- Defect fuses must only be replaced by fuses with the prescribed rating.
- If fuel leaks from the heater fuel system, arrange for the damage to be repaired immediately by a JE service partner.
- When topping up the coolant, only use the coolant permitted by the vehicle manufacturer, see the vehicle operating manual. Any blending with unpermitted coolant can cause damage to the engine and heater.
- After-running of the heater must not be interrupted prematurely e.g. by pressing the battery disconnecting switch, apart from in the case of an emergency stop.

Accident prevention

General accident prevention regulations and the corresponding workshop and operation safety instructions are to be observed.



2 Operation and Function

Operating instructions

The heater is operated by a control unit. The control unit is accompanied by detailed operating instructions which you will receive from the company installing the heater.

Initial commissioning

The following points are to be checked by the company installing the heater during initial commissioning.

- After installation of the heater, the coolant circuit and the whole fuel supply system must be vented carefully. Comply with the instructions issued by the vehicle manufacturer.
- Open the coolant circuit before the trial run (set the temperature control to "WARM").
- During the trial run of the heater, check all water and fuel connections for leaks and firm fitting.
- If the heater shows a fault during operation, find and eliminate the cause of the fault using a diagnosis unit (Contact JE service partner).

Important instructions for operation

Safety checks before the start

After a longer interval in operations (after the summer months) the fuse must be put in position and / or the heater connected up to the battery. Check that all parts fit firmly (tighten screws where necessary). Check the fuel system visually for any leaks.

Before switching on

Before switching on or pre-programming the heater, adjust the heating control in the vehicle to "WARM" (maximum setting) and the fan to "SLOW" (low power consumption).

In vehicles with automatic heating, adjust the heating control to "MAX" and open the heating vents before switching the ignition off.

Temperature drop (optional)

Temperature lowering only becomes active while the vehicle is running and if the heater (independent heater mode) is switched on. The control stages are reached earlier and the heater's control action is adjusted to the lower heat requirement.

The temperature can be lowered by connecting the positive cable (D+) to connector B2, terminal C3 of the heater cable harness (see circuit diagrams, Page 32 and 34).

Heating mode at high altitudes – up to 3500 m asl

The combustion behaviour of the heater changes with increasing altitude, due to the lower air density. The heater has an automatic altitude detection device which it uses to automatically compensate for the change in air density, i.e. the combustion ratio between fuel and air is adapted to the ambient conditions by reducing the fuel quantity.

Please note!

- The usual switching limit for altitude detection lies between 1000 m asl and 2000 m asl and solely depends on the local climatic conditions.
- The maximum heating output of the Hydronic M10 / M12 in "Altitude Mode" is 8.5 kW.
- The Hydronic M8 Biodiesel does not have an altitude detection device. Unrestricted heating mode is possible up to 1500 m asl.
- Heaters suitable for high altitudes have "H Kit" marked on the side of the nameplate.

Description of functions

Switching on

On being switched on, the switch-on check is displayed in the control unit. The heater starts, whereby the water pump and the combustion air blower start up first. The glow phase of the glow pencils begins simultaneously with distribution of the combustion air. The metering pump starts fuel feed somewhat delayed. The glow pencils are switched off if a stable flame has formed in the combustion chamber.

Heating mode

After starting, the heater runs with "POWER" stage until the water temperature exceeds the "POWER" / "HIGH" changeover threshold.

Hydronic M8 Biodiesel / M10

Then, depending on the heat requirement, the heater switches to the "HIGH – MEDIUM – LOW – OFF" stages.

Hydronic M12

Then, depending on the heat requirement, the heater switches to the "HIGH – MEDIUM 1 / MEDIUM 2 / MEDIUM 3 – LOW – OFF" stages.

If the heating requirement in the "LOW" stage is so small that the cooling water temperature reaches 86 °C, the heater switches from "LOW" to "OFF".

An after-run of approx. 180 seconds follows.

The water pump remains active until the controlled start. If the cooling water has cooled to approx. 72 °C, the Hydronic M8 / M10 heater starts in "MEDIUM" stage, the Hydronic M12 heater starts in "MEDIUM 1" stage.

If the cooling water temperature reaches approx. 55 °C the temperature sensor switches the vehicle fan on.

2 Operation and Function

Operating Instructions for Digital Timer Modulator (701 Series)

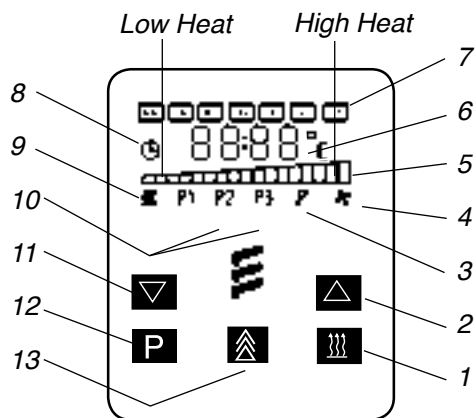

1. Instant Heat ON/OFF key
2. Adjustment Up key
3. Disengaged pre-set symbol
4. Ventilation symbol
5. Temperature ramp (N/A).
6. Current Time, Preset Time and Heating Time.
7. Day selected indicator box.
8. Clock symbol.
9. Heater operation symbol.
10. Preset Programme symbols.
11. Adjustment Down key.
12. Programme key.
13. Set/Programme key.

Clock Settings

Apply power, all display segments flash press key, symbol flashes, set time with and keys.

Press key, day box flashes, set day with and keys.

Press key, seconds reset and clock starts, symbol stays on. This key may be pressed to coincide with a known time signal.

Please Note!

The clock may be adjusted when necessary by pressing and holding the key until symbol flashes.

Please Note!

It is not possible to adjust the clock when the heater is running.

Switching On the heater (Instant heat):

Press key, symbol shows, heater switches on, clock changes to display 1 hr duration and begins countdown.

While counting down the duration time remaining and actual time will alternately flash.

Switching Off the heater (Instant heat):

The heater may be switched off at any time by pressing the key.

General

While counting down the status of the pre-sets may be viewed by pressing the key. Active pre-set symbols will flash, or if no presets are armed then the will flash.

Presets may be engaged or disengaged by pressing the key, without affecting the countdown status.



2 Operation and Function

Please Note!



The temperature ramp (Figure 5) has no effect on heater operation or control of the vehicle blower fan speed or temperature



To Set Timer 'Switch On' Times



Please Note!

First set the "switch on" times for P1, P2 and P3, then set the days On and Off as required.



Press , P1 flashes and either P1 pre-set time or "OFF" shows in display.



- A) If P1 pre-set time shows, press  or  to adjust to a new pre-set time if required.
- B) If "off" is displayed press  key to show the last pre-set time stored.

Press  and  to adjust to a new pre-set time if required. Press  key to toggle P1 pre-set on and off. If no keys are pressed for 8 seconds the display returns to clock mode and P1 setting is stored in memory.

During this 8 second period press  key to move on to P2 setting and adjust as for P1. Similarly press  key again to move on to P3 setting.

To Set Timer Days

Having set P1, P2 or P3 or all three and while P3 symbol is still flashing press  key again, a box will appear around one of days and the display will show either 'On' or 'Off' to indicate whether the Pre-set is required for that particular day. Toggle the day on and off as required by pressing the  key.

To move onto the next day press  key and toggle on and off with the  key. Repeat this procedure for all 7 days. To store all settings in memory press  again or wait 8 seconds without pressing a key. The display returns to clock mode.

Switching On Heater by Timer (Pre-set)

To arm/disarm pre-sets toggle  key.



Dependant upon settings the display will show P1, P2 or P3 or a combination of all three.

When the presets are armed and a pre-set start time is reached the  symbol and the appropriate P symbol will show, heater switches on, clock changes to read duration and begins countdown.



The heater may be switched off at any time by pressing the  key.

Alternatively instant heat mode may be selected by pressing the  key and a further press will switch the heater off.

Please Note!

If all three pre-sets are set to 'off' or all days are set to 'off' the  symbol will be displayed and presses of the  key will be ignored.

To Cancel Timer Pre-Set

Toggle  key to show the  symbol. All Pre-sets have been disarmed.

3 Product Information

Technical data

Heater type	Hydronic M-II				
Heater	Hydronic M10				
Version	D 10 W				
Heating medium	Mixture of water and coolant (max. 50 % water, 50 % coolant)				
Control of the heat flow	Power	Large	Medium	Small	
Heat flow (watt)	9500	8000	3500	1500	
Fuel consumption (l/h)	1.2	0.9	0.4	0.18	
Electrical power (watt)(l/	in operation	86	60	39	35
	at start – after 25 Sek.	120			
	in the control phase “OFF”	32			
Rated voltage	12 Volt		24 Volt		
Operating range	10 Volt		20 Volt		
	15 Volt		30 Volt		
<ul style="list-style-type: none"> • Lower voltage limit: An undervoltage protection in the controller switches the heater off on reaching the voltage limit. • Upper voltage limit: An overvoltage protection in the controller switches the heater off on reaching the voltage limit. 					
Tolerable operating pressure	up to 2 bar overpressure				
Flow rate of the water pump at 0.14 bar	1400 l/h				
Minimum water flow rate of the heater	500 l/h				
Fuel – see also “Fuel quality diesel heaters” page 27	Commercially available diesel (DIN EN 590)				
Tolerable operating temperature	Operation		Not running		
	Heater / Control box		–40 °C to +85 °C		
	Dosing pump		–40 °C to +50 °C		
Interference suppression class	interference suppression class 5 to DIN EN 55 025				
Weight with controller and water pump, without dosing pump	approx. 6.2 kg				



Caution!

Safety instructions for technical data

Failure to comply with the technical data can result in malfunctions.

Please note!

Provided no limit values are given, the technical data listed is subject to the tolerances usually applicable to heaters of ±10% for nominal voltage, ambient temperature 20 °C and reference altitude Esslingen.



3 Product Information

Technical data

Heater type	Hydronic M-II						
Heater	Hydronic M12						
Version	D 12 W						
Heating medium	Mixture of water and coolant (max. 50 % water, 50 % coolant)						
Control of the heat flow	Power	Large	Medium 1	Medium 2	Medium 3	Small	
Heat flow (watt)	12000	9500	5000	3500	1500	1200	
Fuel consumption (l/h)	1.5	1.2	0.65	0.40	0.18	0.15	
Electrical power (watt)(l) _____	in operation	132	86	46	39	35	34
	at start – after 25 Sek.	120					
	in the control phase "OFF"	32					
Rated voltage	12 Volt			24 Volt			
Operating range <ul style="list-style-type: none"> • Lower voltage limit: An undervoltage protection in the controller switches the heater off on reaching the voltage limit. • Upper voltage limit: An overvoltage protection in the controller switches the heater off on reaching the voltage limit. 	10 Volt			20 Volt			
	15 Volt			30 Volt			
	Tolerable operating pressure						
Flow rate of the water pump at 0.14 bar	1400 l/h						
Minimum water flow rate of the heater	500 l/h						
Fuel – see also "Fuel quality diesel heaters" page 27	Commercially available diesel (DIN EN 590)						
Tolerable operating temperature _____ Heater / Control box _____ Dosing pump	Operation			Not running			
	–40 °C to +80 °C			–40 °C to +85 °C			
	–40 °C to +50 °C			–40 °C to +85 °C			
Interference suppression class	interference suppression class 5 to DIN EN 55 025						
Weight with controller and water pump, without dosing pump	approx. 6.2 kg						



Caution!

Safety instructions for technical data

Failure to comply with the technical data can result in malfunctions.

Please note!

Provided no limit values are given, the technical data listed is subject to the tolerances usually applicable to heaters of ±10% for nominal voltage, ambient temperature 20 °C and reference altitude Esslingen.

4 Installation

Siting the Heater

The heater can be mounted in a port / starboard locker, engine room, or other stowage area, provided those areas do not form part of, or are enclosed within the accommodation area.

The heater should be mounted in a dry protected position but with due regard to other aspects of the installation i.e. exhaust, fuel lines, water pipes, electrics. For instance whatever exhaust length is supplied the heater body must not be more than this length away from the exhaust skin fitting.

The final area chosen to site the unit should be well ventilated. If this is not possible a means of ventilating the area will have to be provided, i.e. a duct to atmosphere with intake cowl.

The heater should be mounted at the lowest point in the installation so as to minimise the possibility of air locks and poor circulation. Should this not be possible the heater should not be mounted higher than 500mm above the mounting plane of the lowest component. See *Figure 1*.

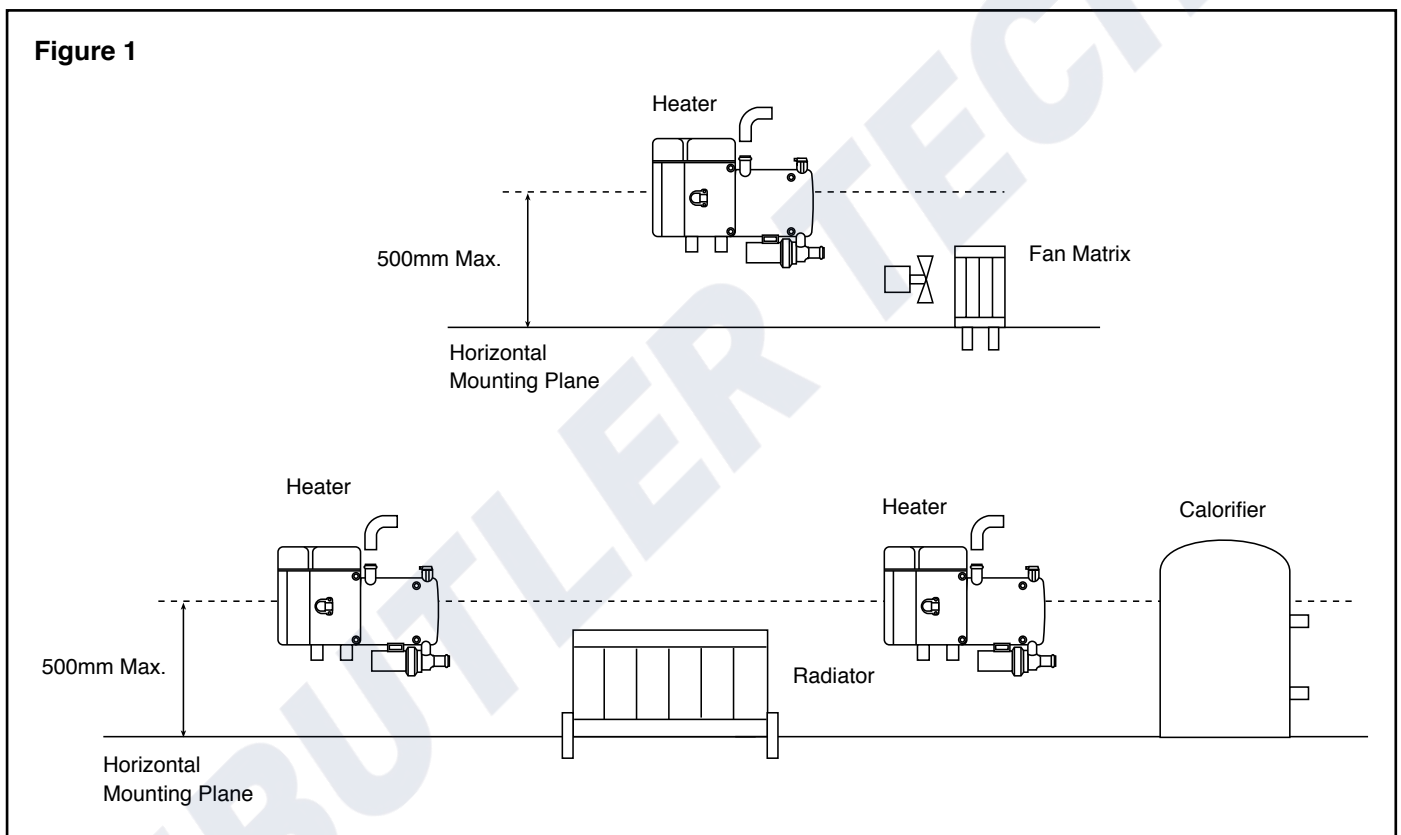

4 Installation

Fixing the Heater in Position

The heater should be fixed in position using the bracket provided. The bracket can be removed for fixing as required.

Access to the heater should be provided to enable routine maintenance to be carried out along with the rectification of minor faults e.g. replacing the glow pin, fuse, testing the overheat switch.

The heater should be mounted horizontally and within the angle of deviation. See *Figure 2*.

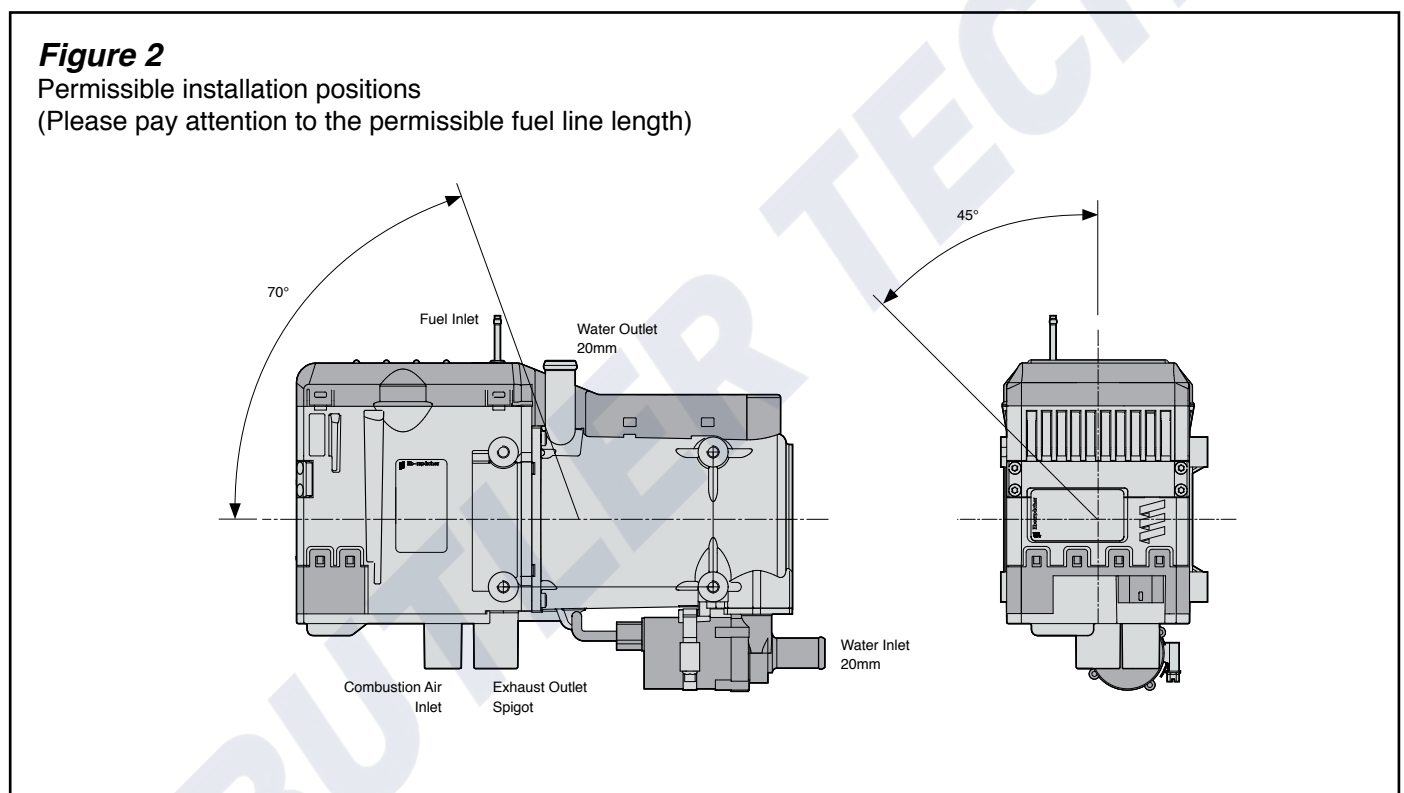

4 Installation

Siting the Header Tank

The header tank should always be connected to the return pipework going to the water pump. The header tank should be sited in a position where it can be easily topped up. It should be mounted at a height not less than 100mm above the highest component on the installation. The highest component on the installation could be the pipework, radiator, fan matrix or calorifier *Figure 3*.

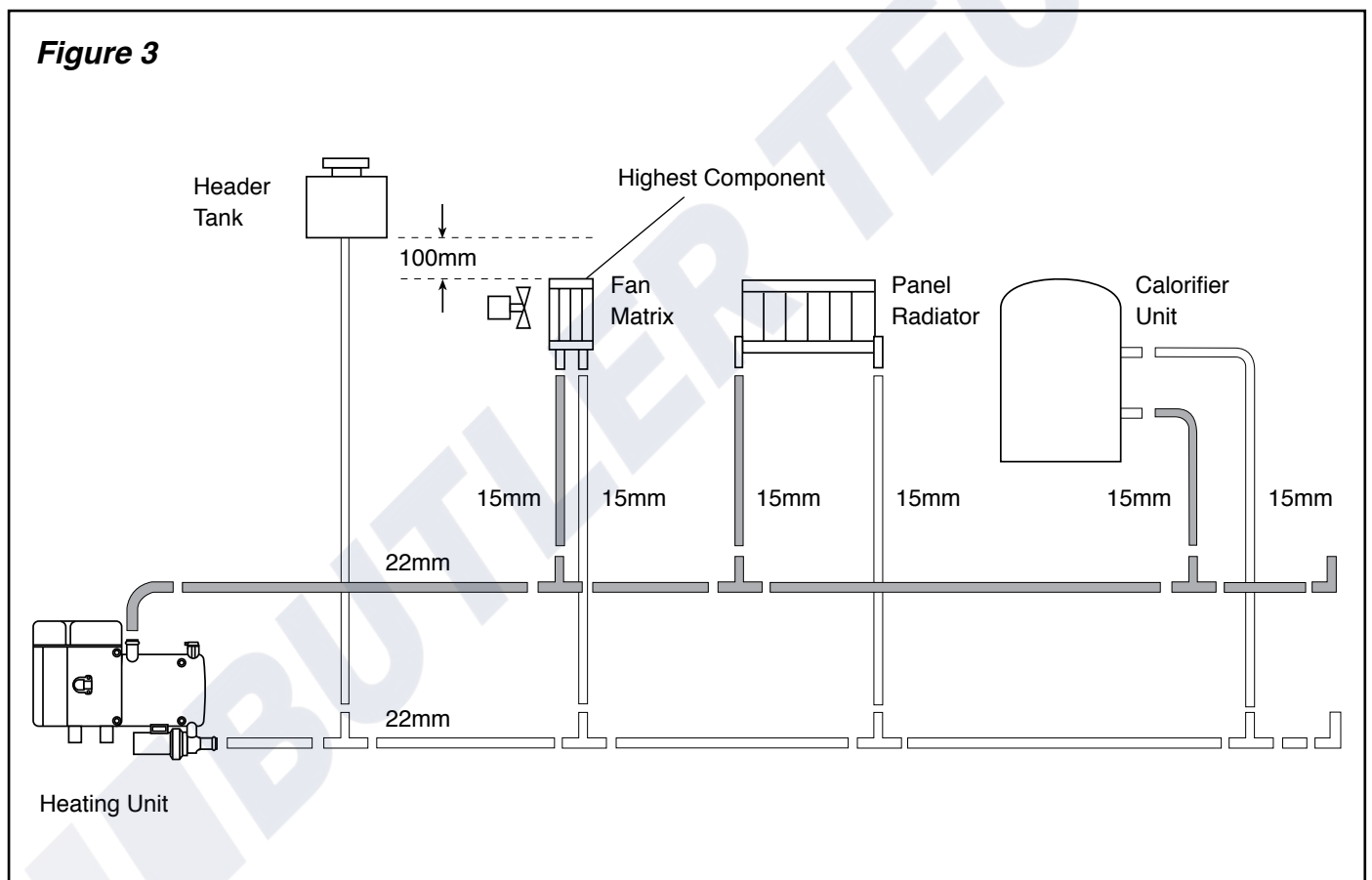



4 Installation

Siting the Radiator

The siting of the radiator is rather limited as it must be fitted to an unrestricted vertical surface.

Prior to fixing the radiator in position care must be taken to ensure that enough space has been allowed on either side and below the radiator to enable the regulating valves and inter-connecting pipework to be fitted.

The fitting of the various parts to the radiator are, as *Figure 4*.

Please Note!

When fitting the regulating and lockshield valves to the radiator it is recommended to use a proprietary brand of jointing compound (PTFE tape, Bos White and Hemp).

Please ensure that one circuit on the system is left open (heads or similar) to ensure a flow round the system when the heater is operational.

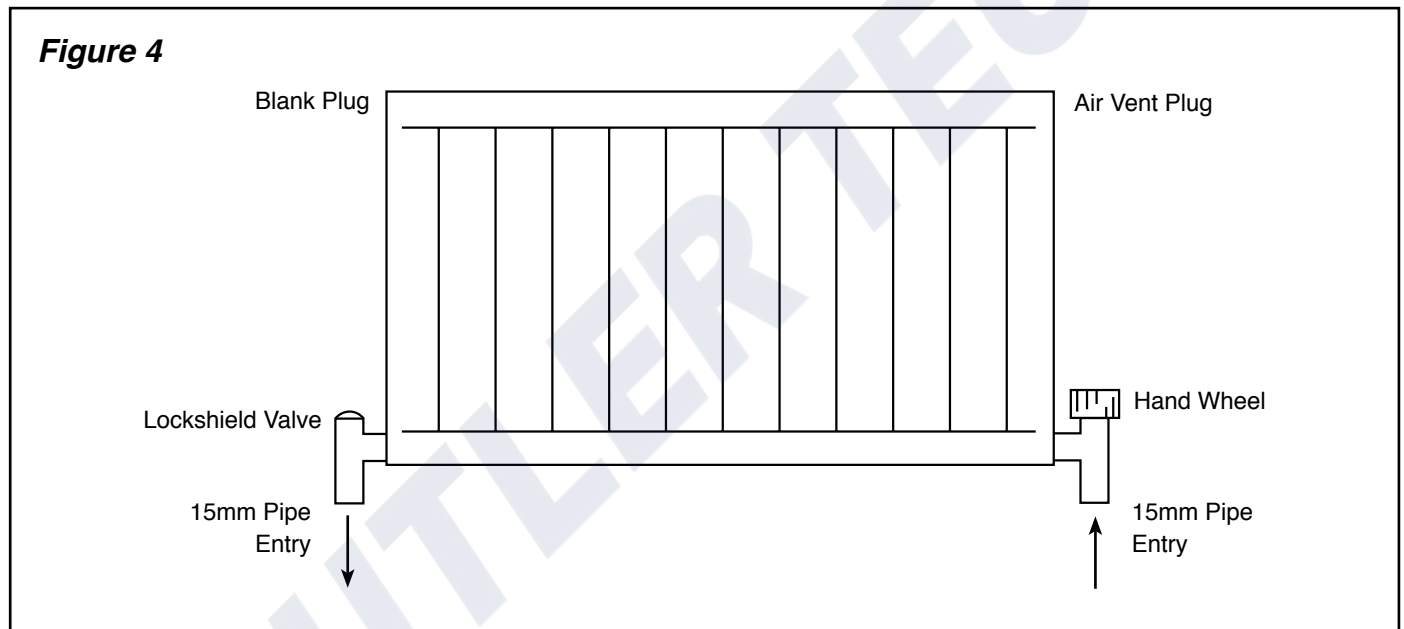

4 Installation

Siting the Fan Matrix

The fan matrix can be fitted in any convenient area that can provide:

1. An adequate through-put of air.
2. Access for interconnecting the pipework.

The matrix is normally fixed to a horizontal surface as *Figure 5*.

Where it is difficult to fix the matrix to a horizontal surface we have provided in the fitting kit two small brackets to enable vertical fixing as *Figure 6* and *Figure 7* (1.5kW only).

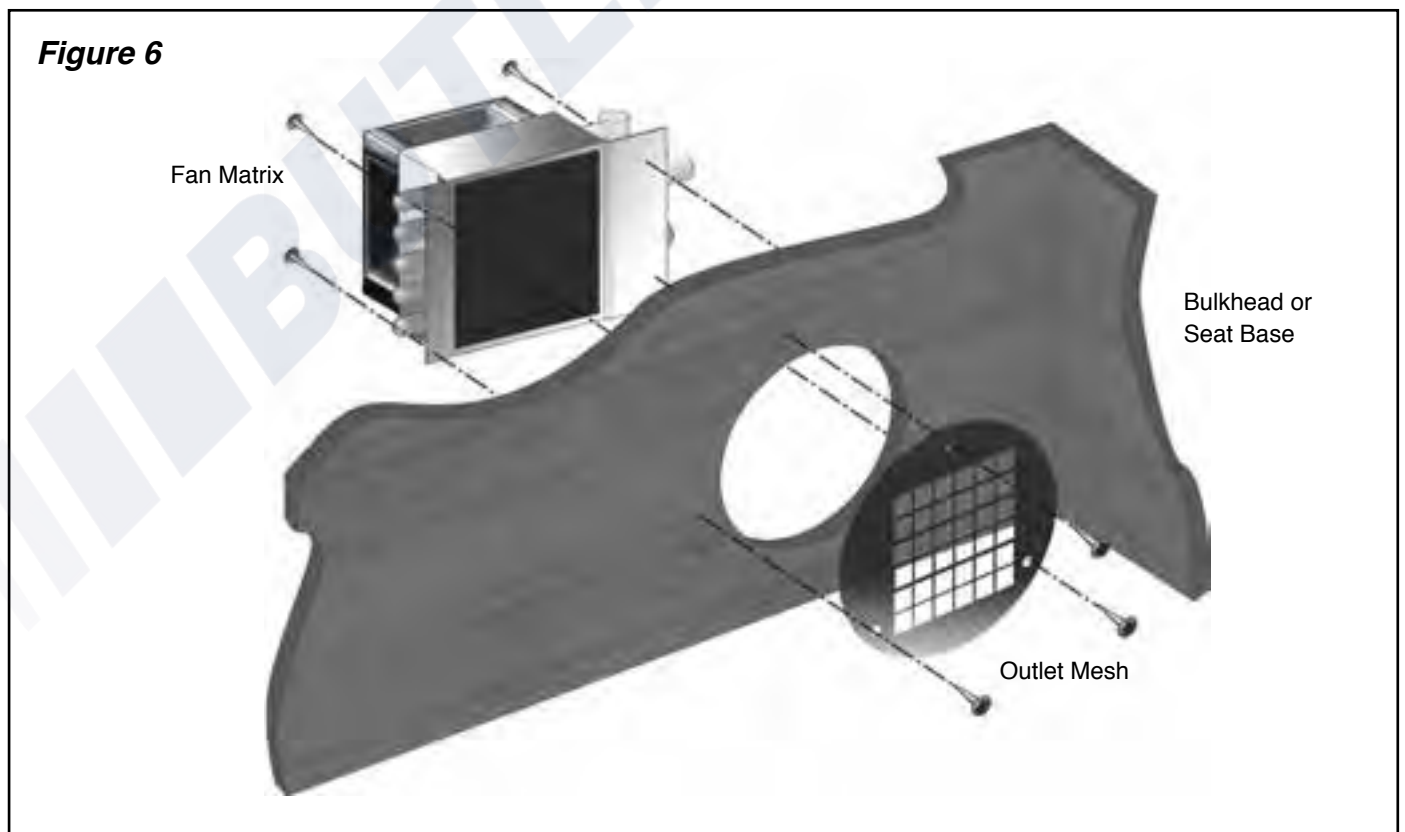
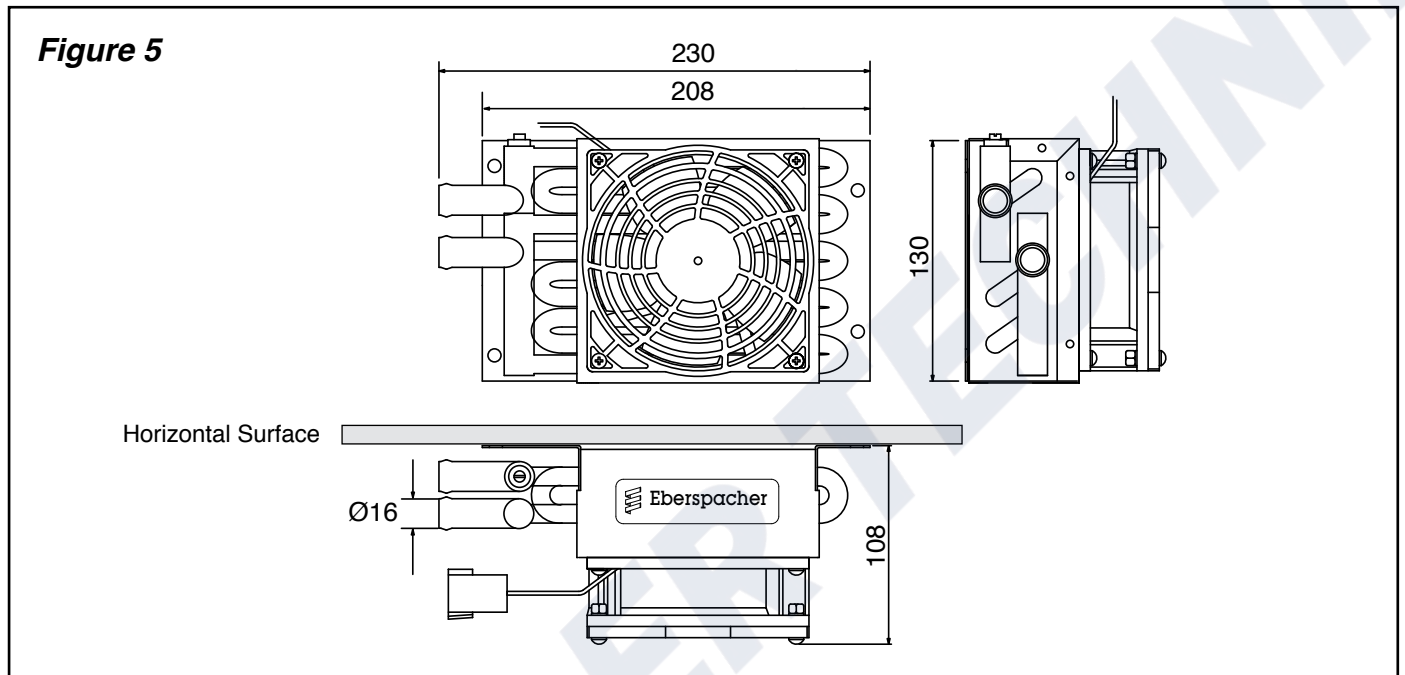



4 Installation

The interconnecting pipework between the main run (22mm) and the matrix is 15mm with flexible rubber connections between the 15mm and the matrix. See *Figure 7*.

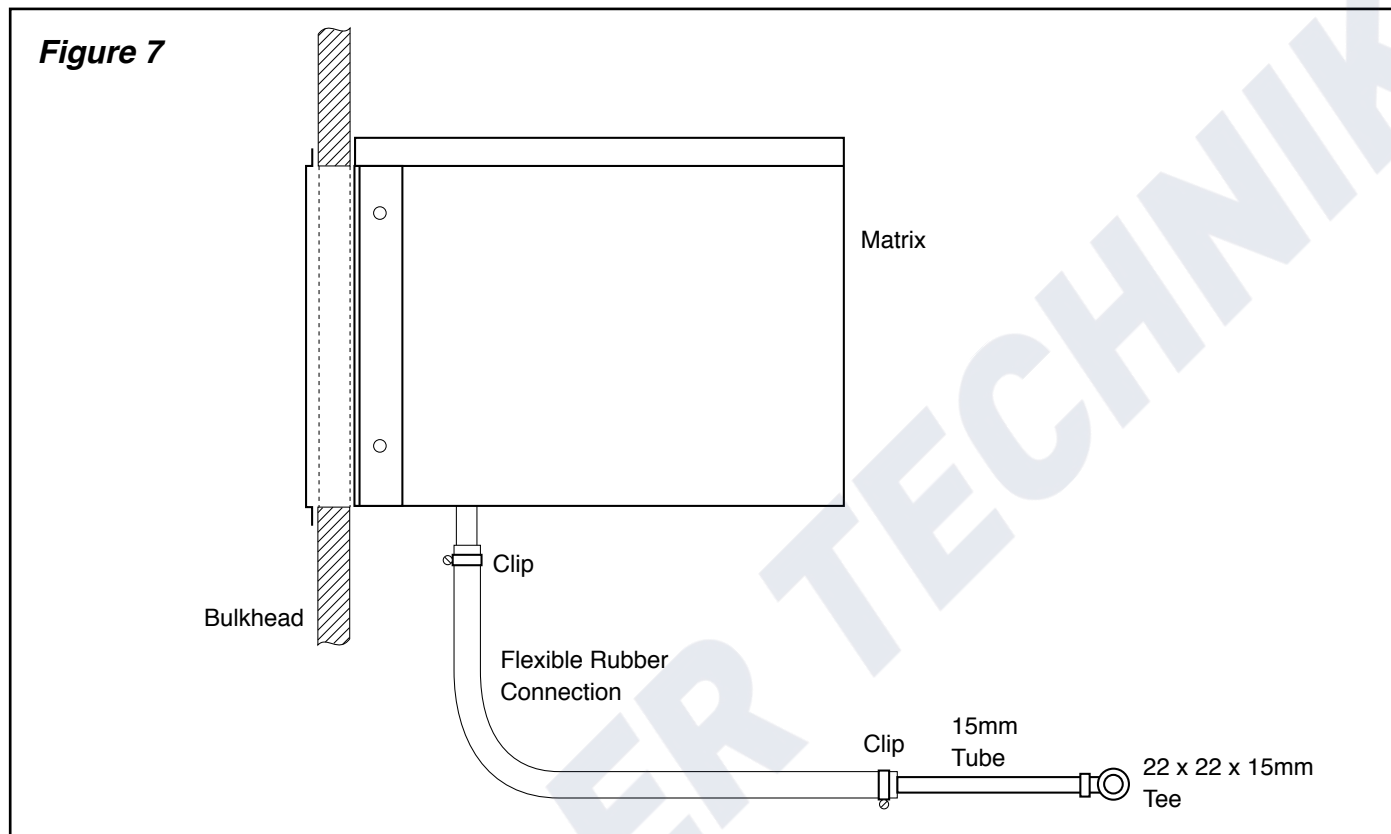

When fitting more than two fan matrix to any one system it will be necessary to fit regulating valves to each matrix in order to balance the system. See *Figure 8*.

Regulating valve Eberspächer Part Number 11032 (15mm) and 11033 (22mm).

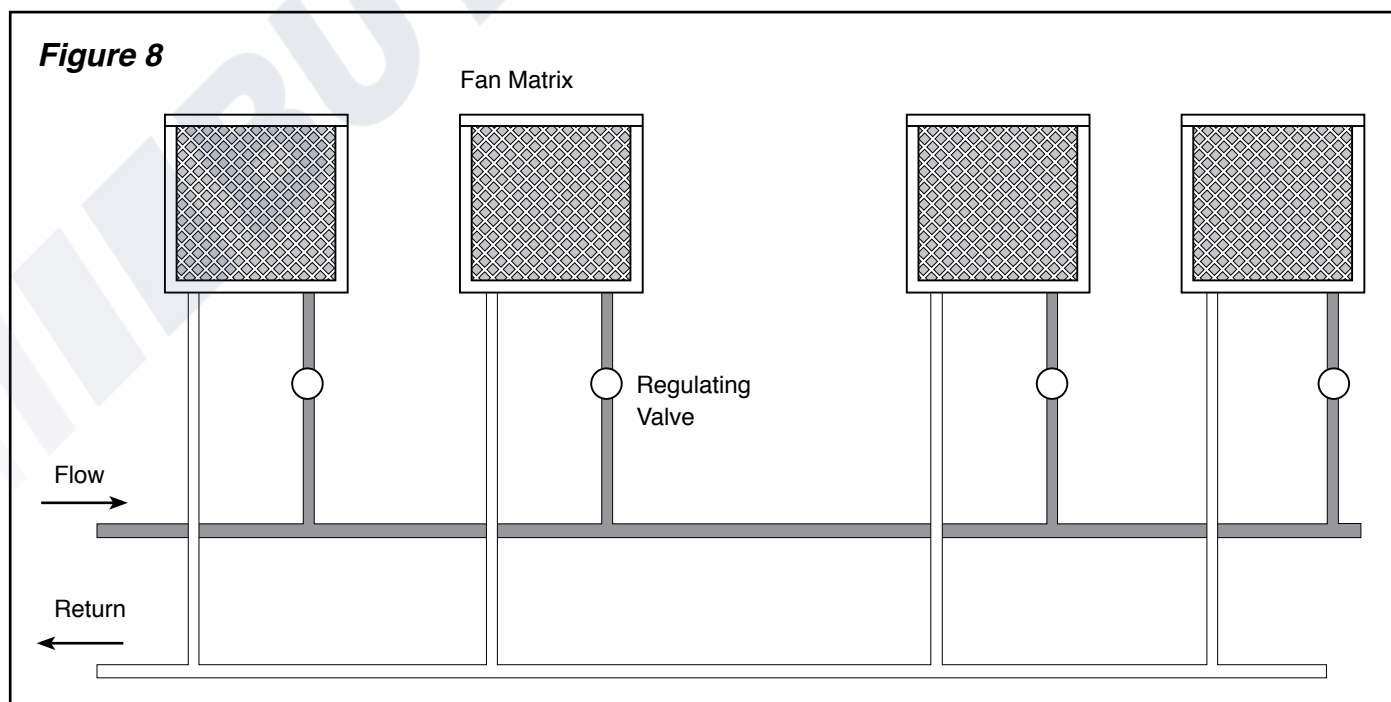

4 Installation

Connection of the Calorifier Unit

A marine calorifier is a water storage tank heated by the engine or independent heating unit. It is robustly constructed to withstand the operating environment and resembles a domestic hot water cylinder.

Connection of the calorifier unit can either be:

1. To an existing system.
2. To a new fitment.

Existing

On most installations the calorifier will already form part of the existing installation and will be directly connected to the engine, or heated by an electric immersion heater via a generating set.

To connect the calorifier into the central heating system, that has previously been heated by the engine or an immersion heater will require.

- (A) The two pipes coming from the engine to the calorifier to be disconnected and the inlet and outlet ports on the engine sealed off. Note use blanking off caps approved by engine manufacturer. Following the blanking off of the engine and the removal of the pipes, the calorifier can then be reconnected, as shown in *Figure 9*.
- (B) When the calorifier is heated by electrical means only, the water heating coils maybe blanked off. These blanks will require to be removed from the calorifier and the two 1/2" BSP fittings provided, fitted. Connection of the calorifier to the central heating system should be as shown in *Figure 9*.

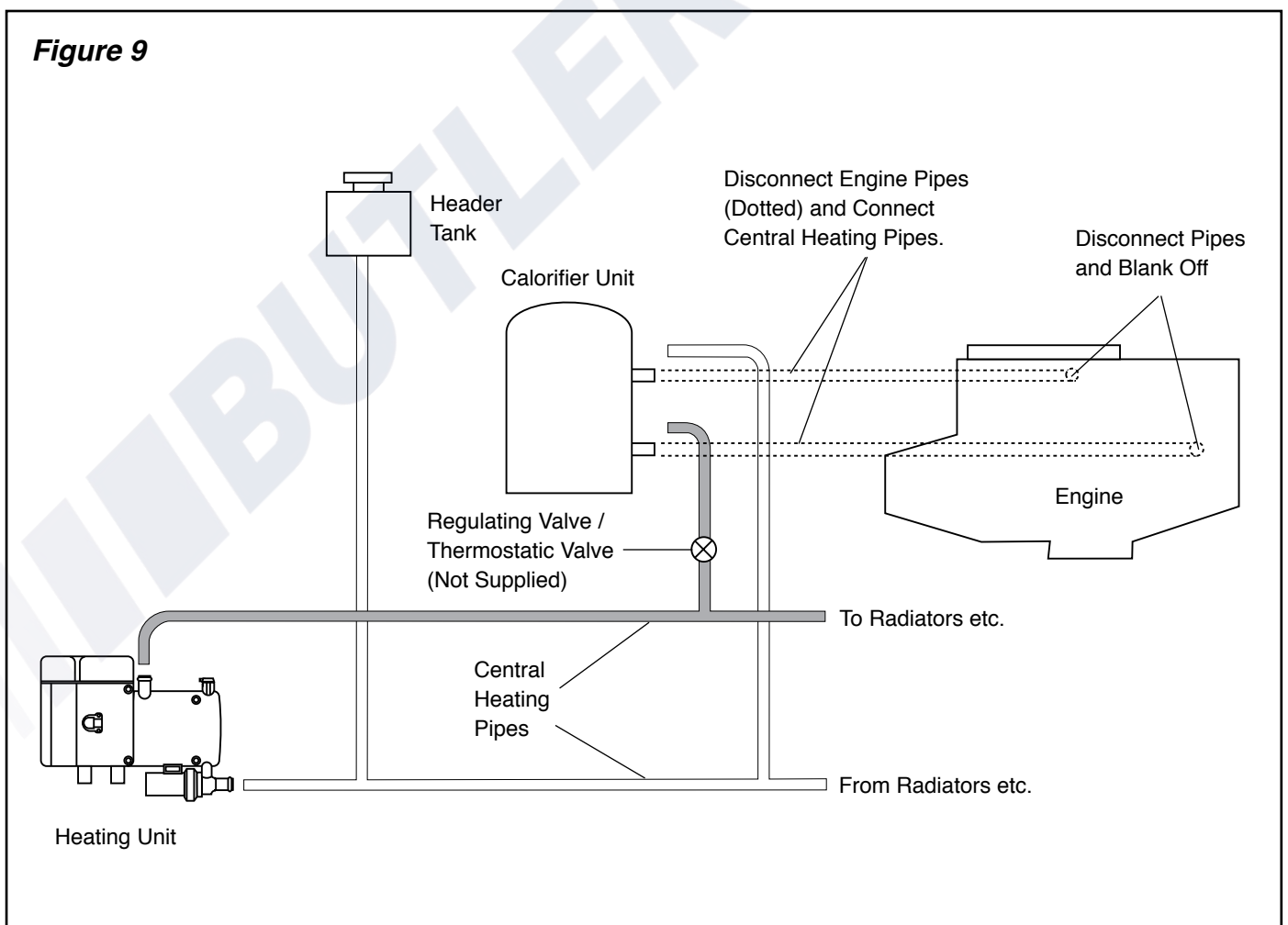



4 Installation

Assembling the pipework and fittings

Hep²O polybutylene pipework and fittings have been supplied with your kit.

Connections must be fitted correctly otherwise leakage will occur.

Figure 10

DO NOT slacken the retaining nut when inserting pipework IT WILL NOT ASSIST JOINTING.

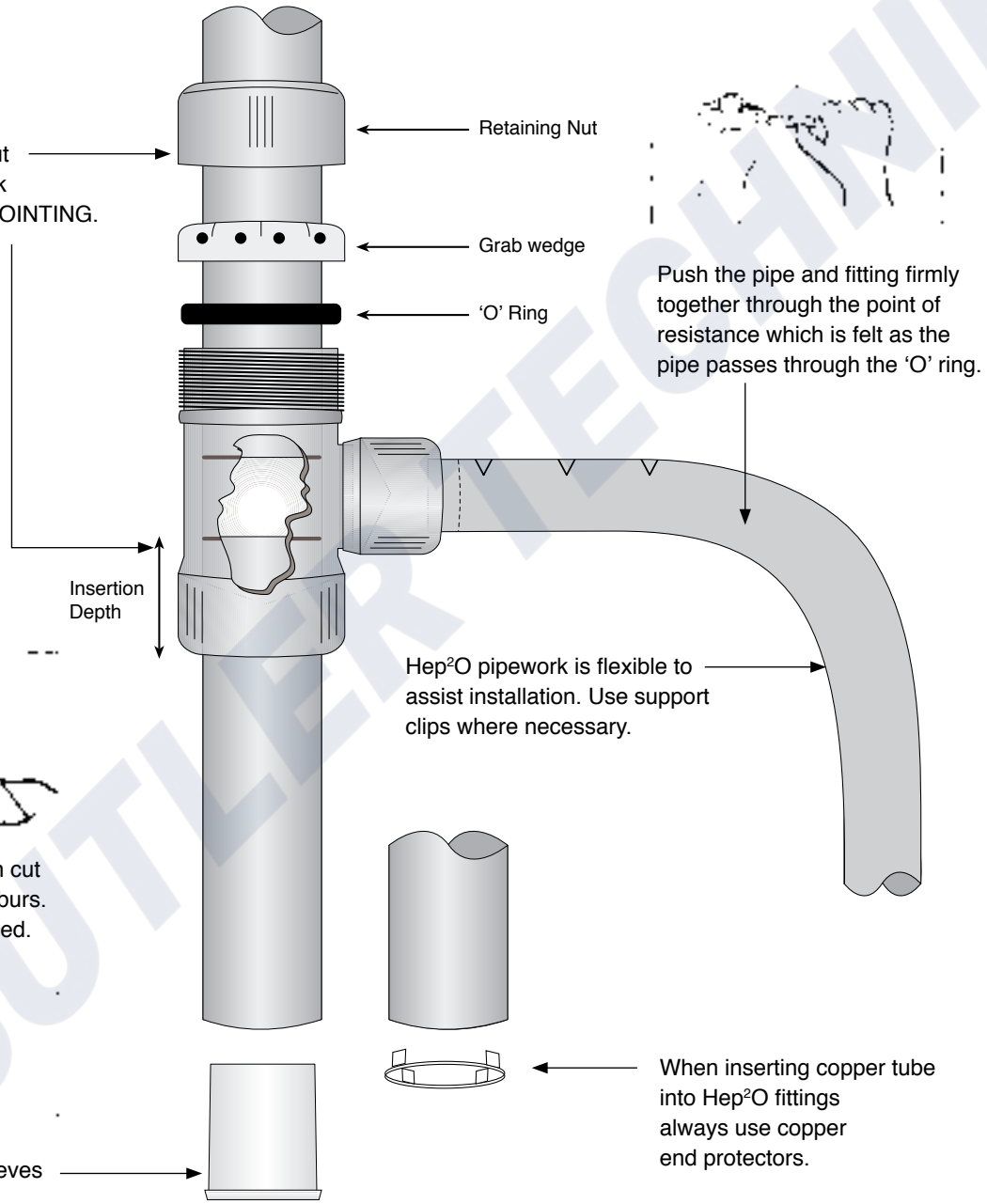

Pipework must be clean cut squarely and free from burs. Pipe cutters must be used.

Always use support sleeves in pipe ends.

Hep²O pipework is flexible to assist installation. Use support clips where necessary.

Push the pipe and fitting firmly together through the point of resistance which is felt as the pipe passes through the 'O' ring.

When inserting copper tube into Hep²O fittings always use copper end protectors.

- **DO NOT Hammer fittings onto pipework**
- **DO NOT Insert damaged or uneven pipe ends**
- **DO NOT Partially insert pipework**
- **DO Use end protectors when inserting copper pipe**
- **DO Ensure pipework is secure in fittings**
- **DO Always use support sleeves (Except copper pipe)**

4 Installation

New Fitments

New fitments of calorifier and cold water systems are normally undertaken by boatbuilders, repair yards, or Eberspächer marine specialist dealers. Some points worthy of note are:

1. The calorifier can be located in any convenient position, provided that it is mounted below the header tank of the central heating system. This reduces the possibility of any air locks.
2. Should you want to retain the convenience of heating the calorifier via the engine, a twin coil calorifier can be fitted. One coil is connected to the engine system and the second is connected to the central heating system.

Routing the Associated Pipework

Prior to installing any pipework, it is better to mark the length of pipe you intend to use as the flow with coloured tape or similar.

The main pipework (22mm) should be run in parallel from the position of the heating unit to the vicinity of the farthest away heating component (radiator).

The pipework should be seen as straight as possible with the minimum of bends, differing levels etc.

The pipework should be well supported throughout its length and secured in position with the clips provided.

Component circuits teed off the main run should be 15mm, as *Figure 3*.

The cutting of any tube and any joints should be to the manufacturers instructions, see *Figure 10*.



4 Installation

Exhaust - Exhaust Skin Fitting

The exhaust from the heater should be vented to atmosphere by means of the flexible exhaust tube and exhaust skin fitting.

The position chosen for the exhaust skin fitting must take into account the length of flexible exhaust supplied.

The skin fitting must be fitted to an outside surface, such as the hull, transom coaming etc. see *Figure 11*.

The skin fitting should be positioned to avoid any exhaust fumes from entering the boat accommodation or fresh and combustion air to the heater.

The skin fitting should be mounted as high above the water line as possible in an area not subjected to direct or indirect under way spray as the heater operates on a totally dry exhaust.

Please Note!

1. *The skin fitting must not be fitted to a deck or horizontal surface. Should it be necessary to fit the exhaust skin fitting on this plain, a special fitting is available from your Eberspächer Dealer.*
2. *Under no circumstances connect the heater exhaust to an engine or any other exhaust system.*

*The flexible exhaust pipe used to inter-connect the heater and exhaust skin fitting should be fitted as *Figure 12*.*

Figure 11

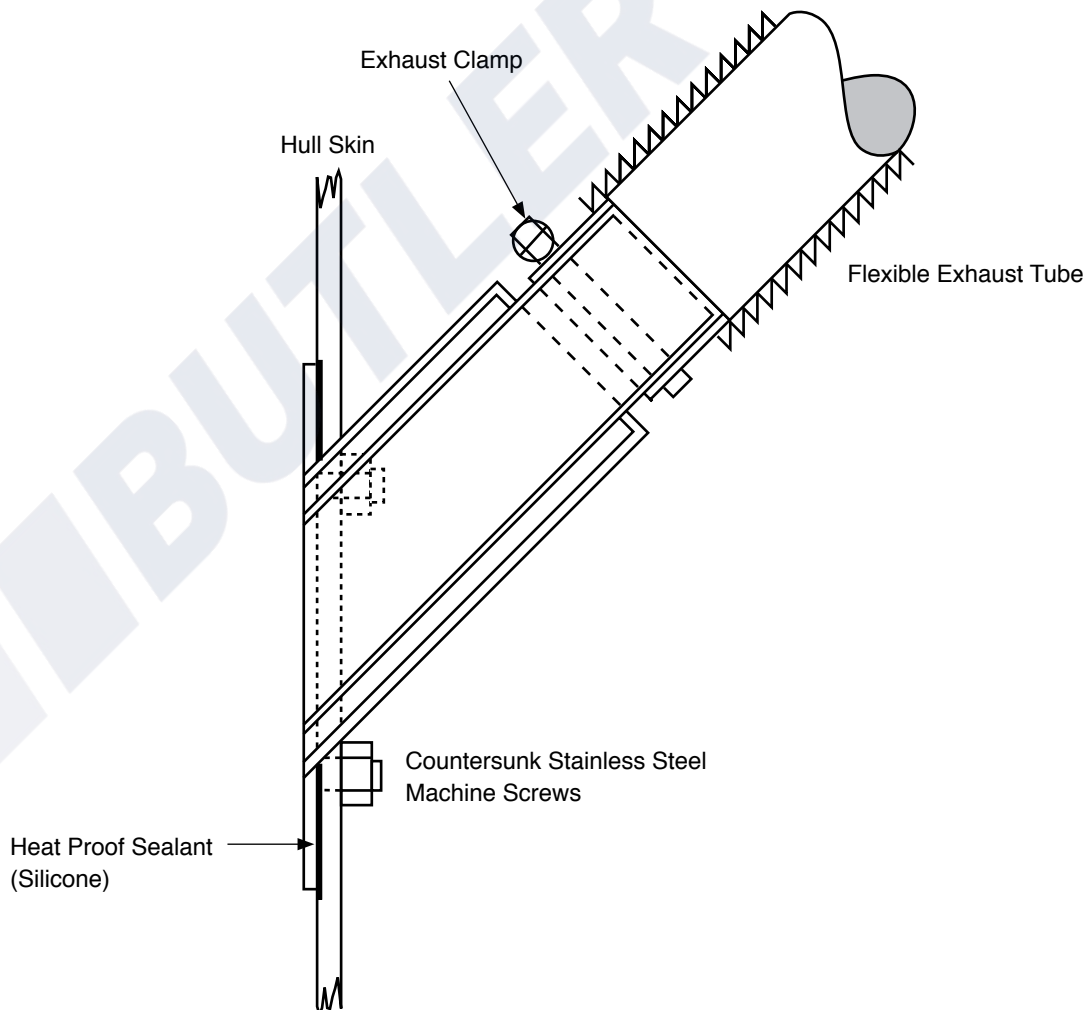

4 Installation

Figure 12

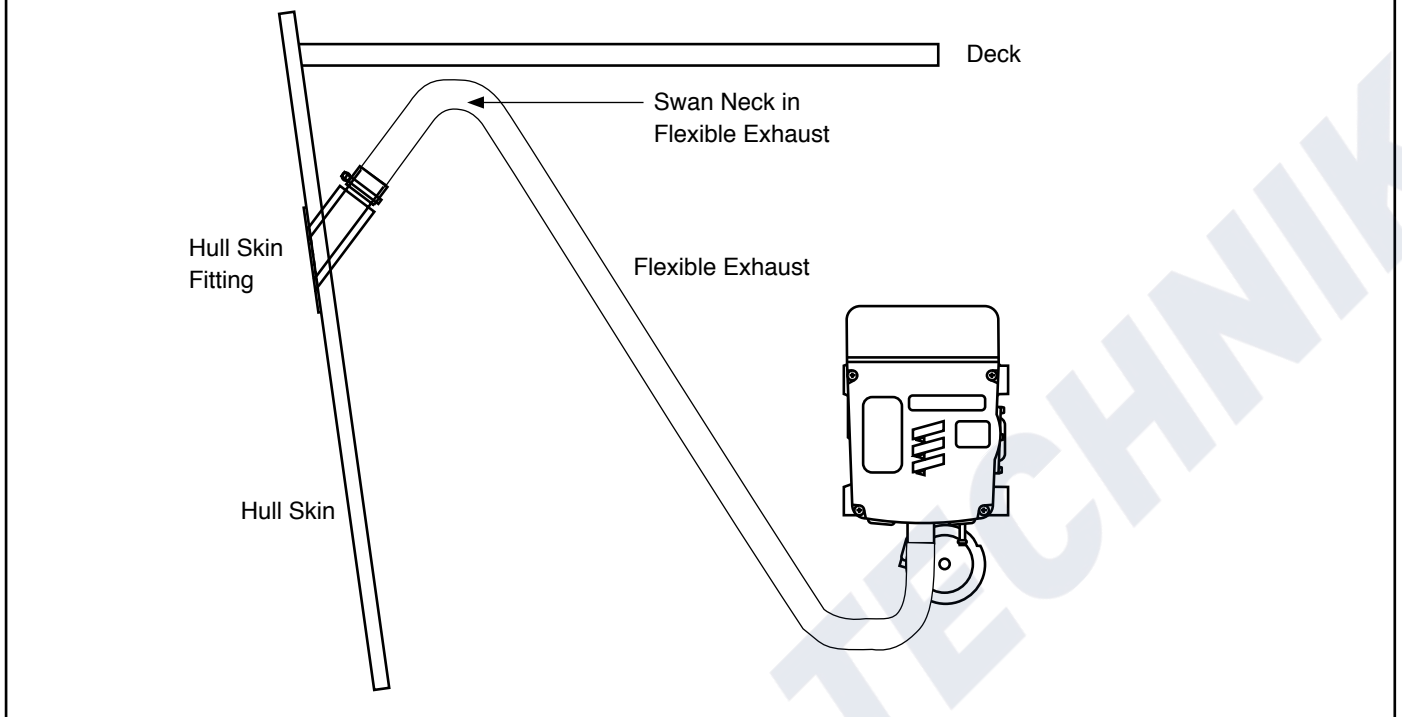

Exhaust - Flexible Exhaust

The exhaust supplied with the kit should satisfy the requirements of the majority of installations. Should you require to increase or shorten the standard length please consult your nearest Eberspächer Dealer.

The exhaust supplied in the kit is pre-wrapped in woven fibre/silicone with the appropriate adaptors to fit the exhaust skin fitting and heater exhaust. Two clamps are also included for securing each end of the exhaust.

Please Note!

1. *Ensure that all exhaust connections are properly fitted and secured to avoid any leakage of exhaust fumes.*
2. *The exhaust pipe will become hot in operation and should not be allowed to bear on plastic pipe, cables, sails etc.*
3. *Care should be taken to run the flexible exhaust pipe to ensure an all round air gap using the stand off arrangement provided. See Figure 13.*

Figure 13

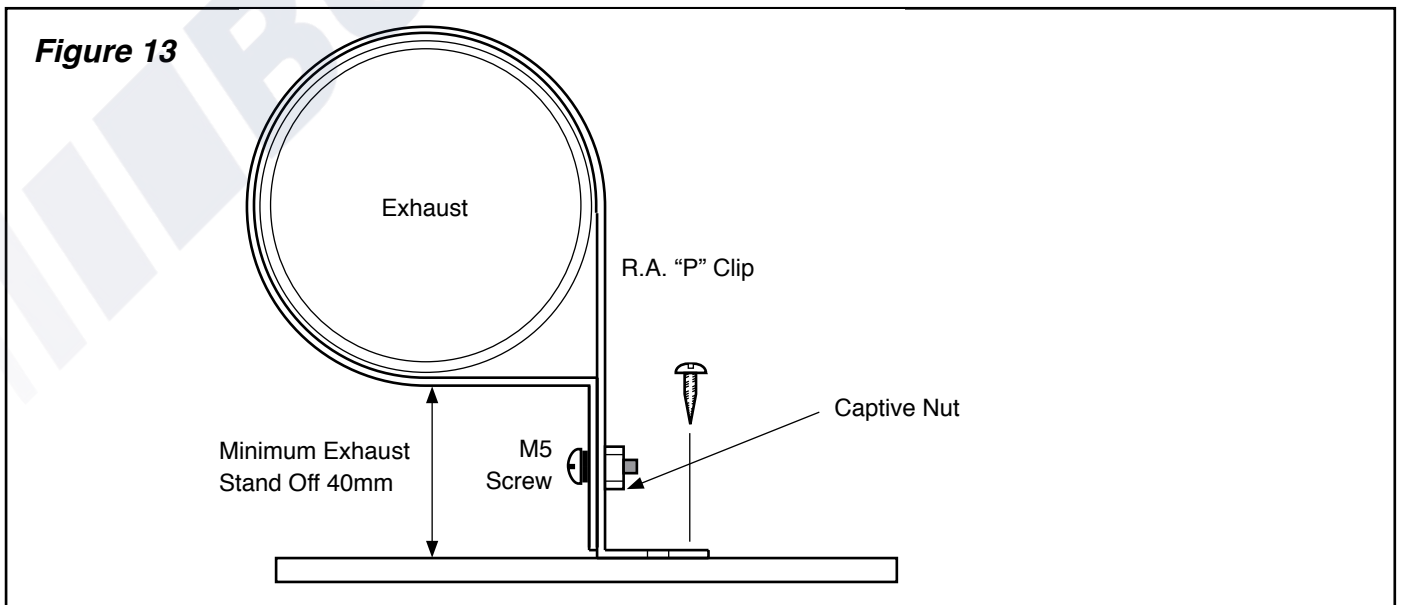



Installation

Combustion air system

Mounting the combustion air system

The universal installation kit includes an intake silencer, inner Ø 25 mm for the combustion air.

The intake silencer must be installed and, for heating mode up to 1500 m asl, can be extended by up to 2 m max. using a flexible pipe (inner Ø 25 mm) and a connection pipe (outer Ø 24 mm) – not included in the scope of supply.

Fasten the intake silencer and where applicable the flexible pipe at suitable points in the vehicle using fastening clips and cable ties.

Please note!

- Comply with the regulations and safety instructions for this chapter on page 4 – 7.
- Extension of the intake silencer is not allowed if mainly heating mode is used at high altitudes (over 1500 m asl).
- Use pipe clips to secure all connections in the combustion air system.
- For installation in ships and boats, see marine catalogue, if necessary consult the manufacturer.



Caution!

Safety instructions for the combustion air system!

- The combustion air opening must be free at all times.
- Position the combustion air intake to be sure that exhaust fumes cannot be sucked in with the combustion air.
- The combustion air intake must not get clogged with dirt and snow.
- Install the combustion air intake system sloping slightly downwards.
- If necessary, make a drain hole approx. Ø 5 mm at the lowest point to drain off condensation.
- Avoid tight bends when laying the intake silencer and flexible pipe.

Allowable combustion air and exhaust pipe length

Figure 14

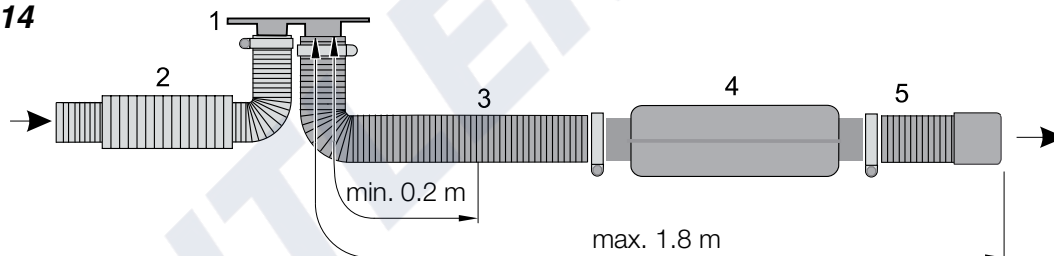

With a combustion air system consisting only of one intake silencer, heating mode is possible up to an altitude 3500 m asl (with Hydronic M10 / M12 only).

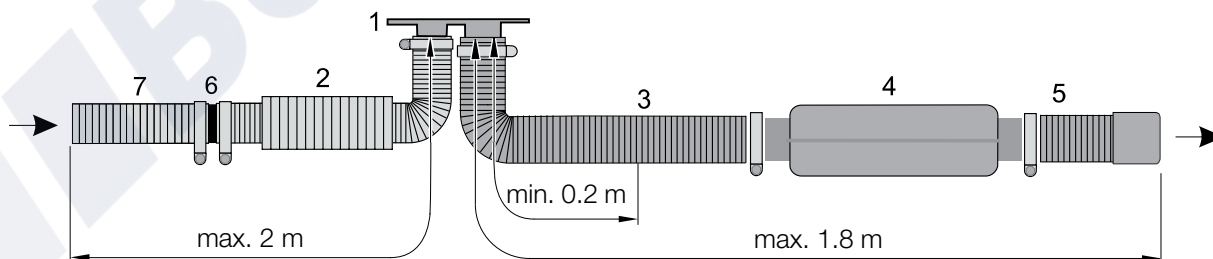

With a combustion air system consisting of one intake silencer and an extension, heating mode is possible up to an altitude of 1500 m asl (all heater models).

- | | |
|--|--|
| 1 Heater flange | 4 Exhaust silencer |
| 2 Intake silencer, 565 mm long
(Order No. 20 1689 80 05 00) | 5 Flexible exhaust end pipe |
| 3 Flexible exhaust pipe | 6 Connector (Order No. 25 1226 89 00 31) |
| | 7 Flexible pipe (Order No. 10 2114 21 00 00) |

4 Installation

Fuel System

The fuel system supplied comprises of a fuel standpipe, a quantity of fuel line, shut-off valve, connectors and a fuel-metering pump.

The diagram illustrates a typical installation using a fuel standpipe, which is the preferred method for the fuel take off. This minimises any problems caused by over pressuring, fuel starvation and air leaks that can occur if connected to an engine fuel line.

However, fuel can be taken from an engine fuel line if it is approved by Eberspächer, and the engine / boat manufacturer (See technical description manual). Unapproved connection may affect the terms of your warranties.

Installing the Standpipe

The fuel standpipe supplied must only be fitted to the top of the fuel tank and on an even surface. It must not be fitted to the side or bottom of the tank.

Install the standpipe as shown.

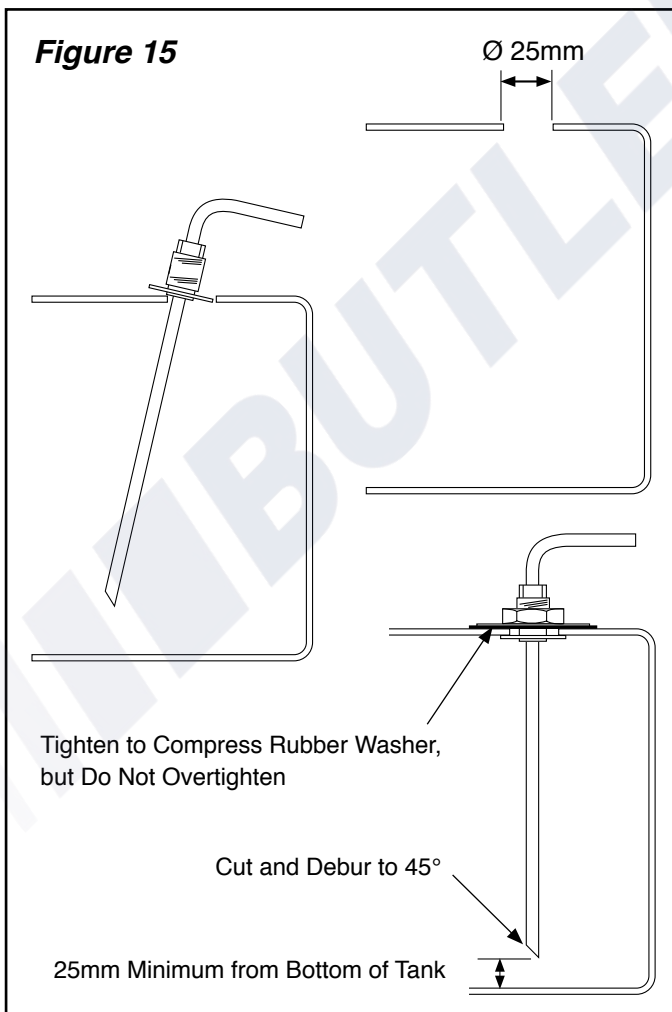

Positioning the Fuel-Metering Pump

When installing the fuel-metering pump, take into consideration that it may be audible when in operation, so it should be installed into an area or onto surfaces that will not transmit the sound into the accommodation. The chosen area should also be free from excessive moisture and the fuel-metering pump must be mounted with the electrical connections / pressure side uppermost within the permissible angles shown.

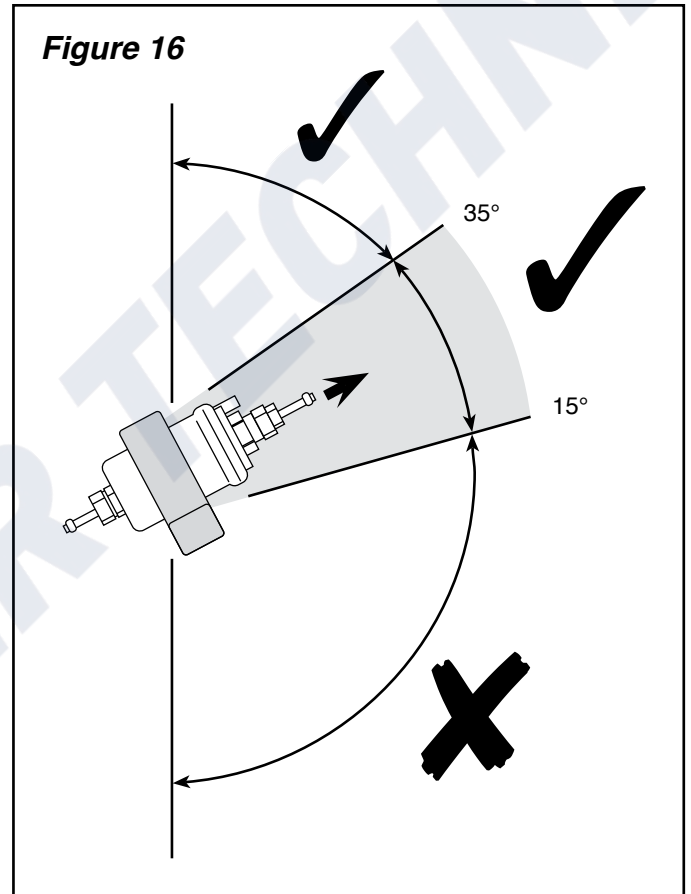

When connecting fuel pipes with a fuel hose always mount the fuel pipes in a butt joint to prevent any bubbles from forming.

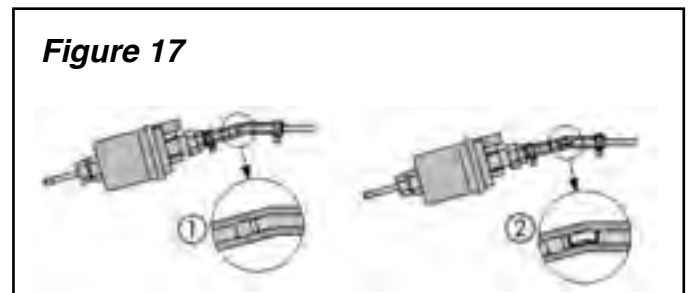

- 1 Correct connection.
- 2 Incorrect connection - bubble formation.



4 Installation

Instruction to Install Fuel System to RCD 94/25/EC & ISO EN10088 Specification

For Eberspächer Heaters up to 6kW

Figure 18

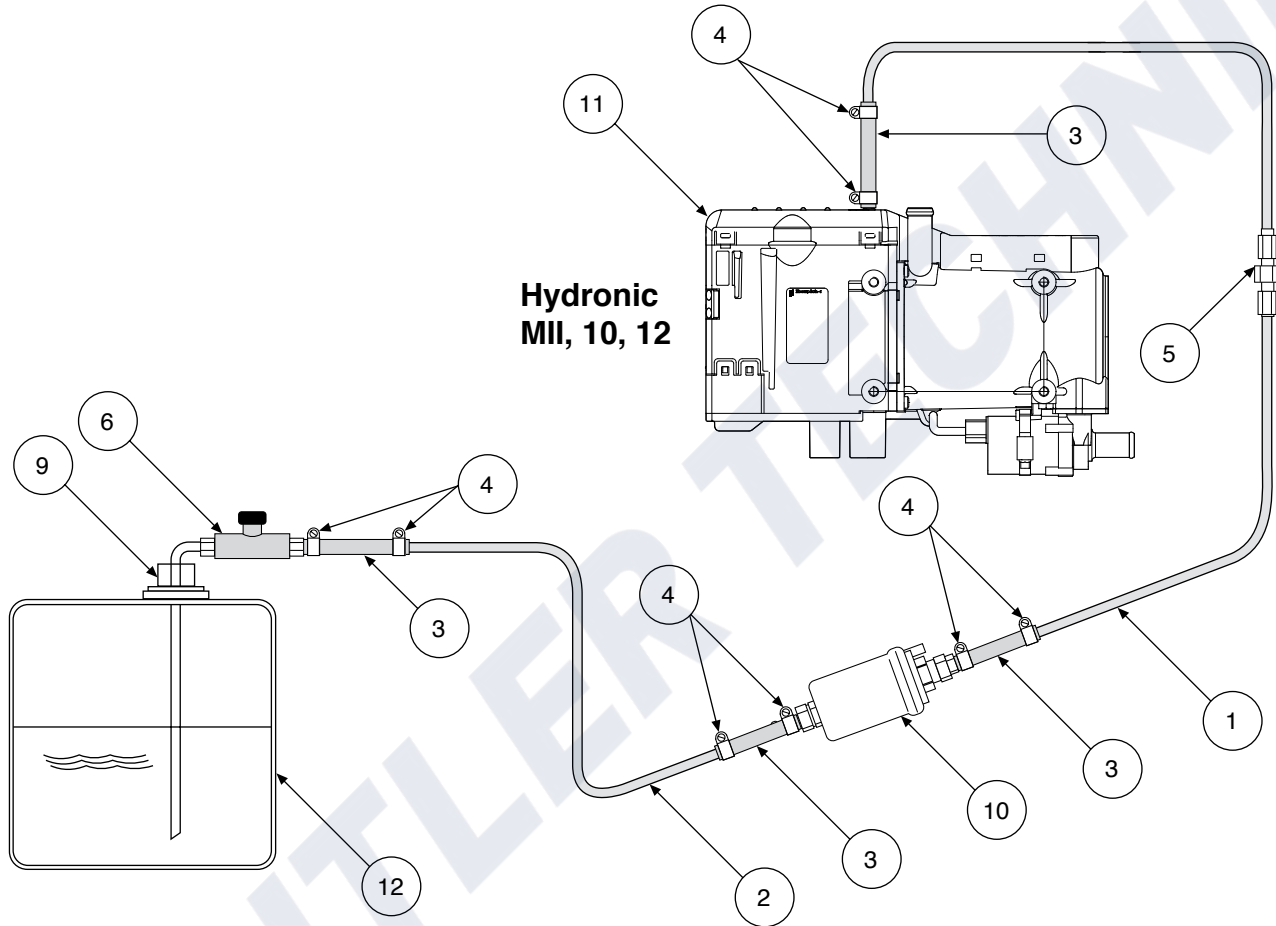

Parts List (for Kit No. E6577)

Item	Description	Part No.
1.	4m M4 Copper Tube Beaded	17874
2.	2m M4 Copper Tube Beaded	17874
3.	Hose 3.5mm ISO 7840	360 75 206
4.	Clip 10mm	11083
5.	M4 Coupling	17015
6.	Fuel Tap Lever M6/M4 Firtree	17887
7.	Clip "P" Brass	17534
8.	Brass Screw	19880
9.	Standpipe 6mm O/D, 2mm I/D	Existing
10.	F M Pump	Existing
11.	Heater	Existing
12.	Fuel Tank	Existing

If 4mm fuel line requires shortening the middle section must be removed and joined with M4 coupling (5).

This allows the use of the beaded ends as required to meet the RCD 94/25/EC and ISO EN10088.

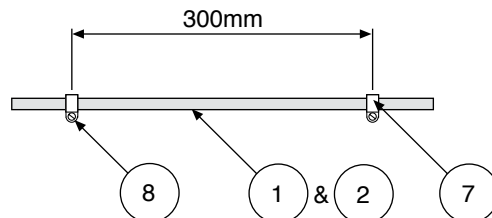

Maximum advisable distance between fuel line clips.

4 Installation

Please Note!

1. If it is necessary to reduce the length of the standpipe (8), ensure that it is cut at 45° and 25mm from the bottom of the tank.
2. Do not reduce or increase the lengths of fuel line supplied without prior reference to an authorised dealer.
3. Changes in the supplied fuel arrangement can result in the pump failing to deliver fuel to the heater.
4. Ensure that the run of the fuel lines are as simple as possible and protected against possible damage.
5. Keep the fuel lines clear of any hot components associated with the heater or engine.
6. Ensure that all fuel lines are secured in position and all joints are butted and secured by clips as Figure 17.

Should you require to shorten any of the fuel lines, a pipe cutter should be used (not side cutters). After cutting, check that the core of the fuel line is not obstructed in any way. Do not cut end brad off. Remove centre section and re-join using compression fitting.

Gravity Feed From Bottom of Fuel Tank and Separate Fuel Tanks

When using a fuel connection from the bottom of the fuel tank it is necessary to ensure that the take off comprises of an upstand as Figure 19 to minimise the ingress of dirt etc into the fuel system.

Initial priming of the fuel system may require several starts of the heater as described under Operating Instructions.

Figure 19

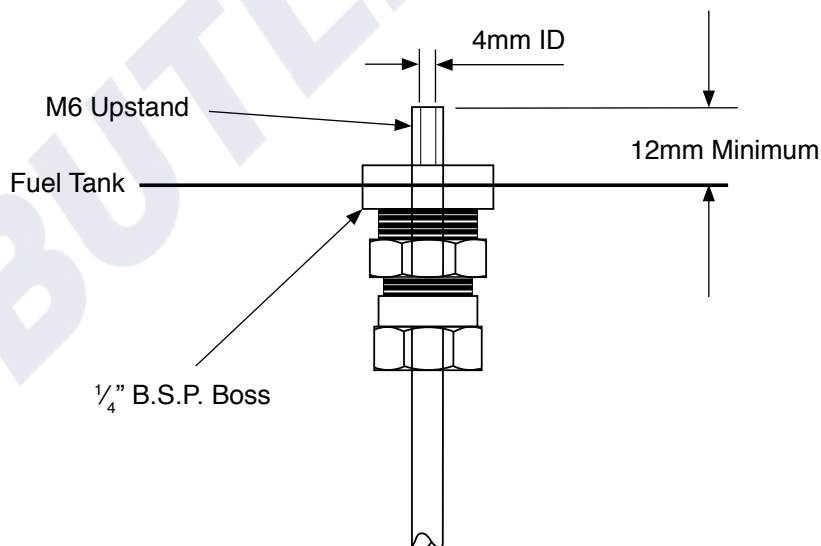



4 Installation

Electrical Wiring of Heater

All electrical connections associated with the heater are made off in connector form, for ease of installation:

1. Mains Loom

The cable routed from the heater to the main electrical supply (battery, main switch or distribution board).

Please Note!

Please ensure that the mains wiring is connected to the correct polarity, red wire - positive (+) brown wire - negative (-).

2. Switch Loom

The cable is routed from the heater to the control position which can be anywhere within the boat taking account of the length of wire.

3. Fuel Metering Pump Loom (F.M.P.)

The cable is routed from the heater or control box housing to the position of the fuel metering pump normally in the vicinity of the fuel tank. The two wires of this loom are coloured green and are not polarity conscious.

4. Fan Matrix Fuse Box Loom

The cable is routed from the heater to the position of the fan matrix fuse box. The fan matrix fuse box is normally sited central to the matrix. The two wires of this loom are coloured and are polarity conscious.

Please Note!

All electrical connections should be smeared with silicon grease in particular the fuel pump connections. Use grease specification shell 8525 or equivalent

Wiring Connections to Main Fuse / Relay Box

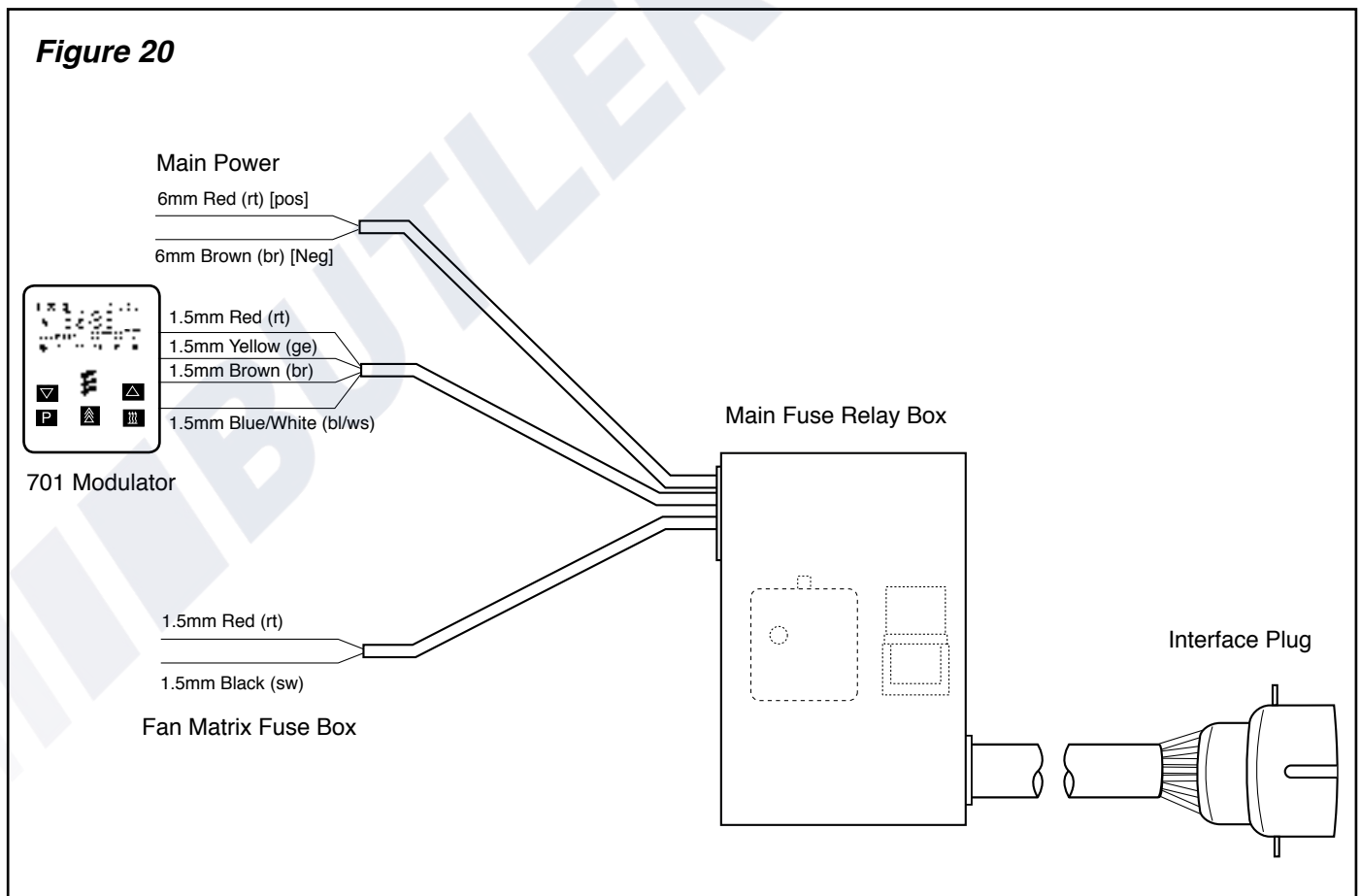

4 Installation

Electrical Wiring of Fan Matrix (Optional Extra)

Locate the fan matrix fuse box in a dry area equal distant between the fan matrix and fix in position with the stainless screws provided.

Locate the matrix thermostat in position and secure.

Route wiring loom No. 3 between the thermostat and the fan matrix. Interconnect as *Figure 22*.

Route wiring loom No. 2 between the fan matrix and the matrix fuse box. Interconnect as *Figure 22*.

Route wiring loom No. 1 between the fan matrix fuse box and the Hydronic 10 heater assembly. Interconnect as *Figure 22*.

For detailed connection of the fan matrix fuse box see *Figure 21*.

Please Note!

If it is necessary to shorten the wiring or remove any of the connectors, please ensure that they are properly made to their original standard. Smear all electrical connections with the silicone grease provided.

M.W.H. Fan Matrix Fuse Box Terminal Identification (Optional Extra)

Figure 21

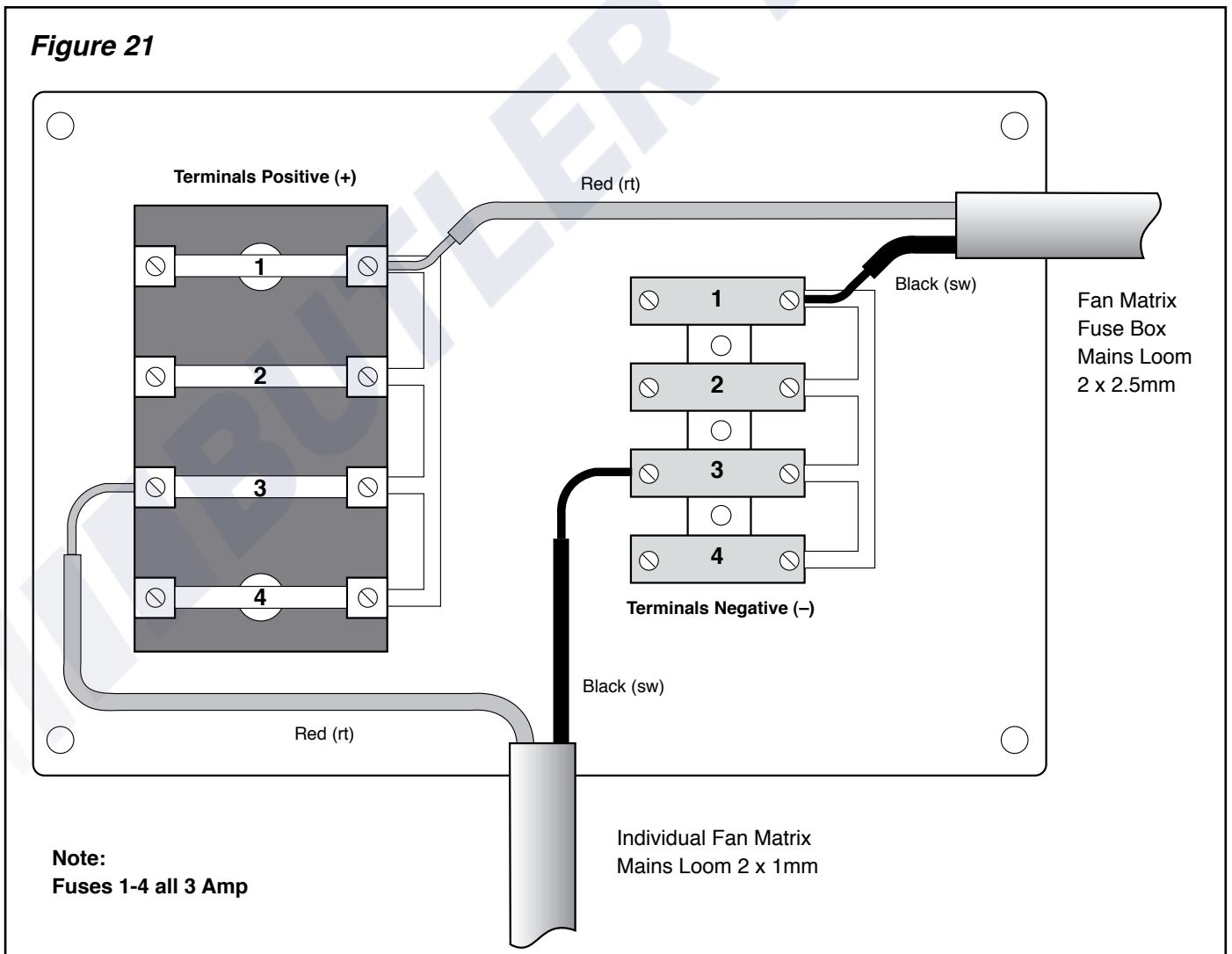



4 Installation

M.W.H. Fan Matrix Control Wiring Diagram

Figure 22

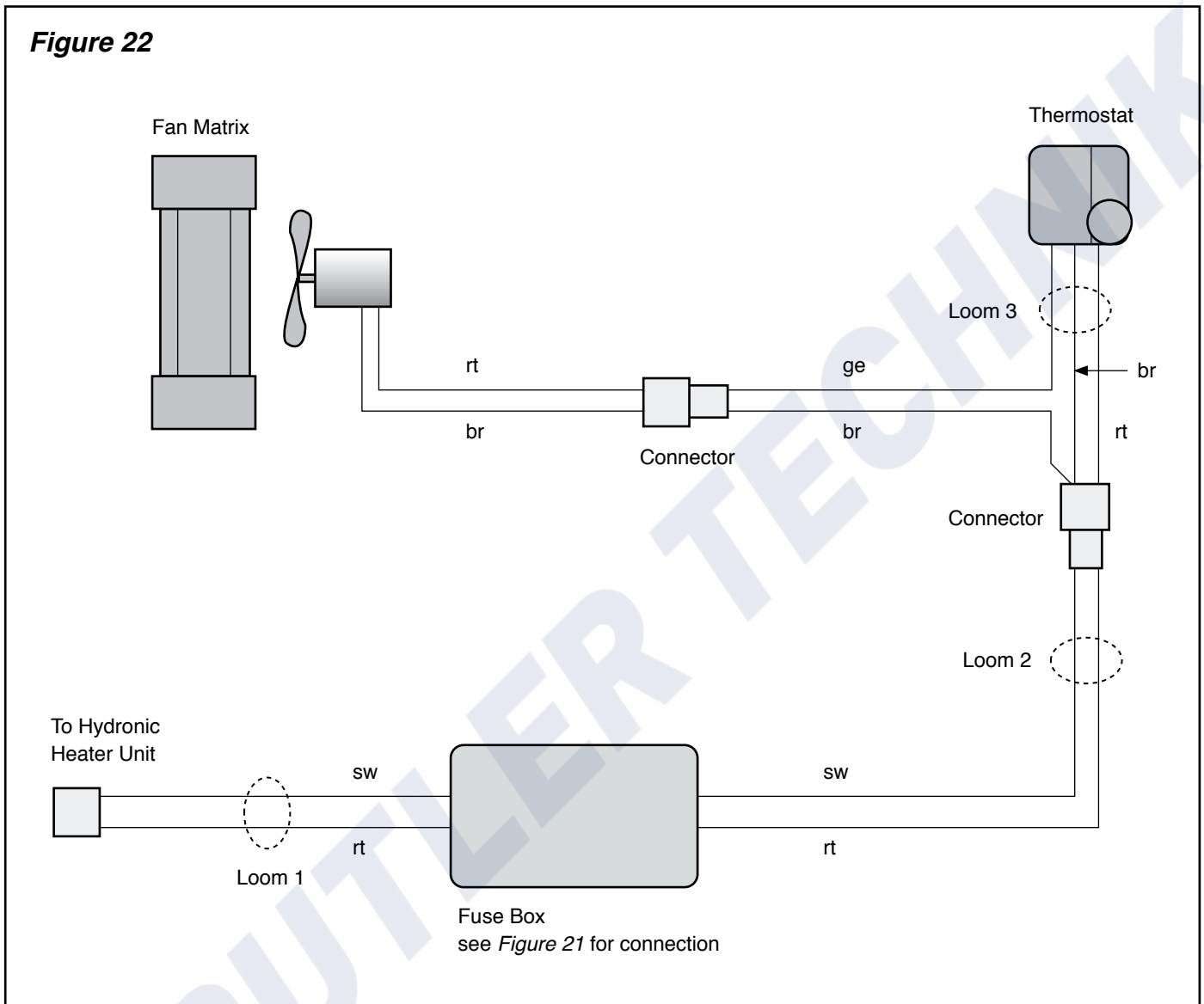

Thermostat Connections

- 1 – rt
- 2 – ge
- 4 – br

Cable Colours

- rt – red
- ge – yellow
- br – brown
- sw – black

5 Electrical System

Parts list for the circuit diagrams Hydronic M-II – 12 Volt / 24 Volt

- 1.1 Burner engine
- 1.2 Glow plug 1
- 1.2.1 Glow plug 2 (optional 12kW /FAME)
- 1.5 Overheating sensor
- 1.12 Flame sensor
- 1.13 Temperature sensor
- 2.1 Controller
- 2.2 Dosing pump
- 2.5.7 Relay, vehicle fan
- 2.5.18 Relay, water circuit change-over –
to be fitted by the customer as required.
- 2.7 Main fuse 12 volt = 20 A
24 volt = 15 A
- 2.7.1 Fuse, actuation 5A
- 2.7.5 Fuse, vehicle fan 25 A
- 2.12 Water pump
- 5.1 Battery
- 5.10 Vehicle fan

a) Connection for control unit

12-pin connection pin assignment (external)

PIN-No.	Connection	Cable cross-section mm ²
A1	Dosing pump	1.5
B1	Solenoid valve, optional	1.0
C1	Relay, blower	1.0
A2	Terminal 31	4.0
B2	Diagnosis cable (OEM)	–
C2	unused	–
A3	Terminal 30	4.0
B3	unused	–
C3	Temperature drop	1.0
A4	Plus signal output.	1.5
B4	Diagnosis (HELJED)	1.0
C4	Heater ON	1.0

- b) Water circuit change-over: Relay makes contact at 68 °C and breaks contact at 63 °C water temperature (with temperature drop 58 °C / 45 °C)
- c) Heater connection
- d) Temperature drop (with positive signal)
- e) Connect the cables in the control's connector
- x) Disconnect cable
- a2) Diagnosis
- a3) Switch-on signal S+
- a4) Power supply plus, +30
- a5) Power supply minus, –31
- a6) (+) Release the battery disconnecting switch (diode: order no. 208 00 012)

Connectors and bush housings are shown from the cable inlet side.

Please note!

To connect the control units

- for EasyStart R+ / R / T: use the 0.75² bl/ws cable, heater connector B2, chamber B4,
- for all other control units: use the 0.75² ge cable, heater connector B2, chamber C4,
- See page 32 for circuit diagram.

Cable colours

- rt = red
- bl = blue
- ws = white
- sw = black
- gn = green
- gr = grey
- ge = yellow
- vi = violet



5 Electrical System

Circuit diagram Hydronic M-II – 12 Volt / 24 Volt

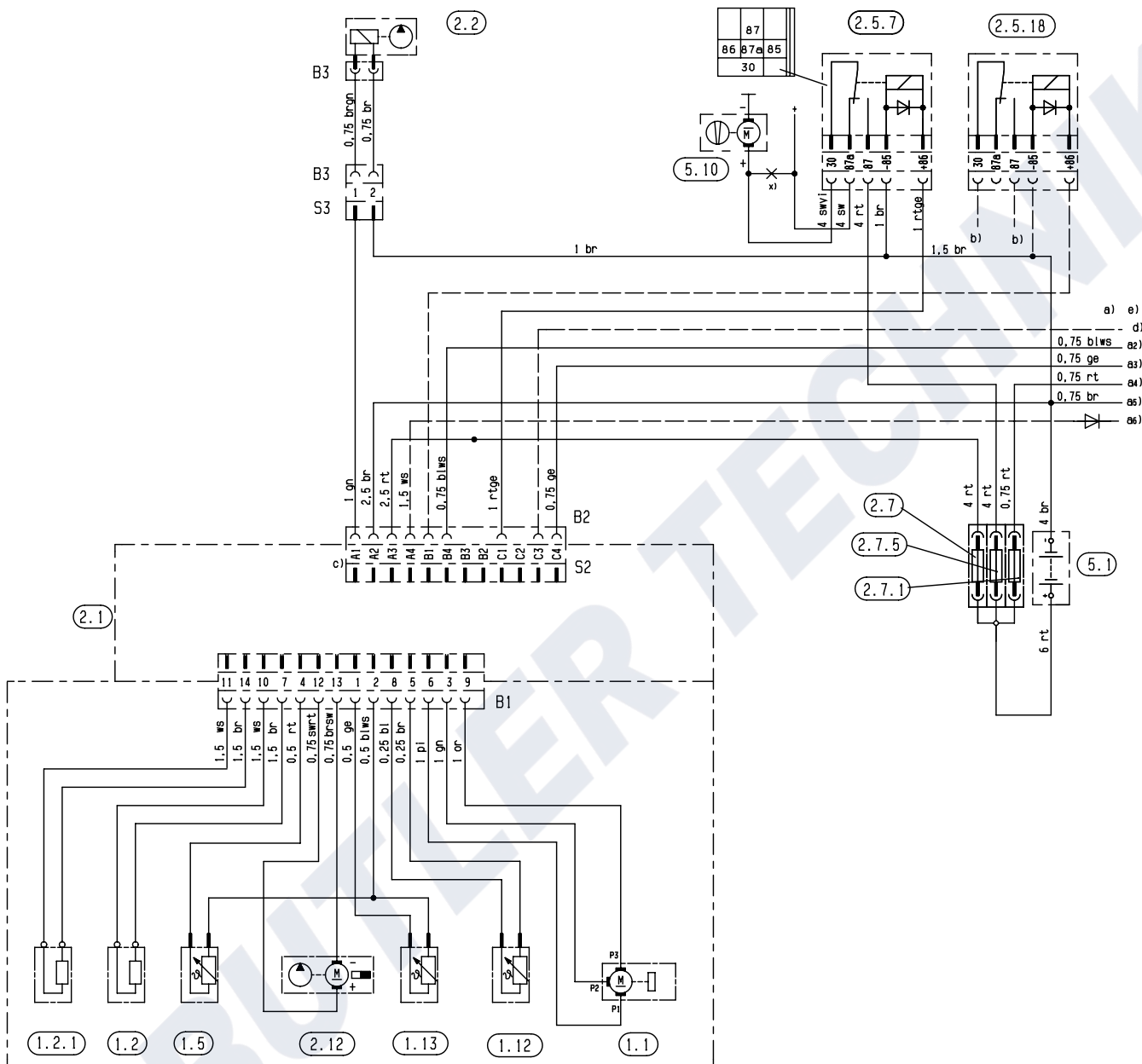

B1

B2

B3

S2

S3

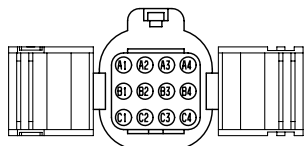
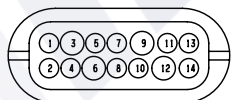

6 Commissioning System

Commissioning the system has been split into a number of sections. They are:

1. Pipework
2. Filling the system
3. Electrical
4. Regulating the system

1. Pipework

You should ensure that all pipe connections are made off as for *Figure 10* and fully secured.

Areas worthy of rechecking throughout the system are:

- (A) Pipe connections (plastic)
 1. End caps fully secured?
 2. "O" rings fitted?
 3. Support sleeves fitted?
- (B) Component connections (plastic - rubber)
 1. Ensure that support sleeves are used on the plastic pipe when joining with rubber.
 2. Check all jubilee clips where used are secure.
- (C) Component connection (plastic - metal)
 1. Ensure joints are secure but not overtightened.
 2. Check that pipe connections to components are not under strain.
 3. Ensure copper end protectors are fitted.

2. Filling the System

Filling the system is made easier by having someone assisting you and following the suggested sequence:

- (A) Open the air vents of all components, *Figures 5 and 8*.
- (B) Open all shut off valves and regulating valves, as indicated in *Figures 5, 7 and 8*.

Please Note!

The liquid used to fill the system initially can be water to test for leaks etc. THE FINAL MIX USED TO FILL THE SYSTEM SHOULD HAVE A MINIMUM CONTENT OF 25% ANTIFREEZE, WHICH ALSO ACTS AS A RUST INHIBITOR.

- (C) Fill the header tank by removing the cap.
- (D) Have your assistant keep a constant check at the air vent on the lowest component, closing it as soon as the component has filled.
- (E) Make sure the header tank is kept topped up to ensure that no air locks are introduced into the system.
- (F) As soon as the lowest component has filled and the air vent closed, your assistant should do each component in turn working from the lowest to the highest.
- (G) With all components and associated pipework filled, care should be taken not to overfill the header tank, as you have to allow for expansion.

Please Note!

The allowance for expansion is normally 30% - 40% of the tank volume.

- (H) Once the system is filled, you should then recheck for any possible air locks by venting each component in turn starting at the lowest and working up to the highest, ensuring that the header tank is kept topped up.



6 Commissioning System

3. Electrical

Prior to switching on you should carry out the following check that all electrical wiring and connections are, as per diagram.

Check that you have the mains wiring connected to the correct polarity, red wire positive (+), brown wire negative (-).

Check the battery state and charge the batteries if necessary by running the engine for 1 hour, or by means of a shore supply and battery charger.

Once the batteries have been charged you are now ready to switch on.

For switching on the unit see Operation.

Due to the fuel lines requiring to be primed with fuel it may be necessary to reset the start process. To reset the start process all you require to do is move the switch to the off position and the back to the on. The reset of the start process should not be operated more that three times prior to checking all fuel lines for loose joints and the tank for sufficient fuel.

Once the heater has ignited, it will take approximately 10 - 20 minutes to get the water in the system warm and 25 - 36 minutes to reach optimum temperature.

Please Note!

These are approximate times as they will depend on the water content of the system and the temperature of the day.

Once the heater has reached optimum temperature and cut from full to quarter heat, (dropped down in speed), go round and check each heating component in turn for temperature. You may experience some components warmer than others and to achieve uniformity will require the lockshield valve, (one without the hand wheel), to be closed slightly if the component is very hot and opened if cold. This process can take a bit of time to achieve uniformity throughout the system.

In the case of radiators the output of heat is controlled by the shut off valves, (the one with the hand wheel).

With the fan matrix the temperature is controlled by a thermostat local to each unit.

Should you require additional control in addition to that provided, any of our dealers listed or ourselves would be more than willing to assist.

7 Service and Maintenance

Service and Maintenance

At least once a season and certainly at the start of a season check all electrical connections for good contact and absence of corrosion.

Check all ducting to ensure no sections are damaged and that the heater fan intake is unobstructed.

Check exhaust connection at heater and skin fitting to ensure no damage to exhaust or combustion air pipes.

Remove and clean glow pin - taking care not to damage the glow spiral or element. Clean with fine wire brushing and emery cloth.

Depending on usage, but certainly every third season or 2,000 hours running we recommend a dealer to be contacted for a service and de-coke of the heat exchanger and replacement of the integral fuel filter.

If the heater is swamped or takes in water, contact your nearest dealer as soon as possible.

Please Note!

For live aboard applications your heater may need to be serviced / overhauled by an appointed Eberspächer dealer every 6 months depending on frequency of use.



8 Notes

BUTLER TECHNIK

8 Notes

BUTLER TECHNIK

BUTLER TECHNIK



Eberspächer

Eberspächer (UK) Ltd.
Headlands Business Park,
Salisbury Road, Ringwood
Hampshire, BH24 3PB

© Eberspächer (UK) Ltd. 2010

No part of this manual may be copied or reproduced in any form
without the express permission of Eberspächer (UK) Ltd.

This publication was correct at the time of going to print however,
Eberspächer (UK) Ltd have a policy of continuous improvement and reserve the right to
amend any specifications without prior notice.