

HYDRONIC L-II

Technical Description, Installation, Operating and Maintenance Instructions.



Heater	Order No.	Order No. – compact version
Hydronic L16	25 2486 02 00 00	---
Hydronic L24	25 2487 02 00 00	25 2487 05 00 00
Hydronic L30	25 2599 02 00 00	25 2599 05 00 00
Hydronic L35	25 2600 02 00 00	25 2600 05 00 00

**Engine-independent water heater
for diesel.**



Eberspächer
A world of comfort

1 Introduction

Contents

Chapter	Title	Contents	Page
1	Introduction	<ul style="list-style-type: none"> • Contents..... 2 • Concept of this manual..... 3 • Special text structure, presentation and picture symbols..... 4 • Important information before starting work..... 4 • Statutory regulations..... 5, 6 • Safety instructions for installation and operation..... 7 • Accident prevention 7 	
2	Product information	<ul style="list-style-type: none"> • Scope of supply / additional parts..... 8, 9 • Technical data, heaters 10 • Technical data for the water pump 11 – 13 • Main dimensions 14 • Main dimensions, compact version 14 	
3	Installation	<ul style="list-style-type: none"> • Permissible mounting position and fastening of the heater 15 • Main water pump dimensions 16 – 18 • Permissible installation position and fixing of the water pump 16 – 18 • Installation location 19 • Installing the heater in a box 20 • Nameplate / Nameplate with EBA No. 21 • Exhaust system (pipes) 22, 23 • Combustion air system 24 • Connection to the cooling water circuit 25 • Water circuit 25 • Fuel supply 26 – 28 	
4	Operation and function	<ul style="list-style-type: none"> • Structure of the heater 29 • Operation instructions / important information for operation 29 • Initial commissioning of the heater 29 • Functional description / Functional diagram 30 • Control and safety devices / EMERGENCY OFF 31 	
5	Electrical system	<ul style="list-style-type: none"> • Heater wiring 32 • Parts list for circuit diagram, heater and cable harness 32 • Heater circuit diagram..... 33 • Cable harness circuit diagram..... 34 • Control units circuit diagrams..... 35 – 39 	
6	Faults Maintenance Service	<ul style="list-style-type: none"> • If any faults occur, please check the following items..... 40 • Troubleshooting 40 • Maintenance instructions 40 • Changing components 40 • Service 40 	
7	Environment	<ul style="list-style-type: none"> • Certifications..... 41 • Disposal 41 • EU Declaration of Conformity 41 	
8	List	<ul style="list-style-type: none"> • List of abbreviations 42 	
9	Maintenance schedule	<ul style="list-style-type: none"> • Maintenance schedule and measurements record 43 – 45 	



1 Introduction

Concept of this manual

This manual aims to support the service company installing the heater and to provide the user with all important information about the heater. The manual has been divided into 9 chapters to make it easier to find the corresponding information quickly.

1 Introduction

Here you find important introductory information about installation of the heater and about the structure of the manual.

2 Product information

Here you will find information about the scope of supply, the technical data and the dimensions of the heater.

3 Installation

Here you will find important information and instructions referring to installation of the heater.

4 Operation and function

Here you will find information about the operation and function of the heater.

5 Electrical system

Here you will find information about the heater's electrics and electronic components.

6 Troubleshooting / maintenance / service

Here you will find information on possible faults, maintenance and technical support.

7 Environment

Here you will find information about certification and disposal of the heater together with the EU Declaration of Conformity.

8 List

Here you will find the list of abbreviations.

9 Maintenance schedule and measurements record

Here you will find the maintenance schedule and the measurement record for heaters.

1 Introduction

Special text structure, presentation and picture symbols

This manual uses special text structures and picture symbols to emphasize different contents. Please refer to the following examples for their meanings and appropriate action.

Special text formats and presentations

A dot (•) indicates a list which is started by a heading. If an indented dash (–) follows a dot, this list is subordinate to the dot.

Picture symbols



Regulation!

This picture symbol with the remark "Regulation!" refers to a statutory regulation. Failure to comply with this regulation results in expiry of the type-approval for the heater and preclusion of any guarantee and liability claims on Eberspächer Climate Control Systems GmbH & Co. KG.



Danger!

This picture symbol with the remark "Danger!" refers to the risk of a fatal danger to life and limb. Under certain circumstances, failure to comply with these instructions can result in severe or life-threatening injuries.



Important!

This picture symbol with the remark "Caution!" refers to a dangerous situation for a person and / or the product. Ignoring this information can result in injuries to people and / or damage to machinery.

Please note!

These remarks contain recommendations for use and useful tips for installation of the heater.

Important information before starting work

Range of application of the heater

The water heater operating independently of an engine is intended for installation in the following vehicles:

- All types of motor vehicles, especially buses and coaches
- Construction machinery
- Agricultural machinery
- Boats, ships and yachts
- Rail vehicles

Please note!

- Installation of the heater in vehicles used for the transport of dangerous goods according to ADR is **not** permitted.
- The heater is primarily intended for installation in buses and is designed for their special requirements. Here it must be noted that installation is not allowed in vehicle spaces used by persons (more than 8 passenger spaces).
Exception: see page 5. Statutory regulations, location of the heater.

Intended purpose of the heater (via the vehicle's own heat exchanger)

- Pre-heating, de-misting windows
- Heating and keeping the following warm:
 - Driver and working cabs
 - Freight compartments
 - Ship's cabins
 - Passenger and crew compartments
 - Vehicle engines and units

On account of its functional purpose, the heater is **not** approved for the following applications:

- Long-term continuous operation, e.g. for pre-heating and heating of:
 - Residential rooms
 - Garages
 - Work huts, weekend homes and hunting lodges
 - Houseboats, etc.



Important!

Safety instructions for the range of application and proper, intended use!

The heater must only be used and operated for the range of application stated by the manufacturer and in compliance with the operation instructions included with every heater.



1 Introduction

Statutory regulations

The Federal Motor Transport Authority has issued an approval for a component according to ECE R122 and ECE-R10 for the heater for installation in motor vehicles, with the following official type-approval markings noted on the heater's nameplate.

Heater type:	ECE type approval mark:
Hydronic L-II	 122 R – 000233 10 R – 045282

The Federal Railway Office has issued a “type approval to Art 33 EBO” for installation of the heater in rail vehicles; the vehicle has the following official type approval:

Hydronic L-II EBA 32AZ3/0097/08

§ Regulations

Excerpt from ECE regulation No. 122 of the European Parliament and the Council

General regulations

- **Operating state display**
 - A clearly visible operating display in the user's field of vision must indicate when the heater is switched on and off.

Regulations concerning installation in the vehicle

- **Scope**
 - Subject to differing stipulations in the following section, combustion heaters must be installed according to the regulations 5.3 of ECE-R122.
 - It is assumed that Class O vehicles with heaters for liquid fuel conform to the regulations 5.3 of ECE-R122.
- **Arrangement of the heater**
 - Parts of the structure and other components near the heater must be protected from excessive heat exposure and possible fuel or oil contamination.
 - The heater must not pose a fire hazard even when it overheats. This requirement is deemed to be fulfilled if adequate clearance is ensured for all parts during installation, sufficient ventilation is provided and fireproof materials or heat shields are used.
 - The heater must not be mounted in the passenger compartment of vehicles in class M₂ and M₃. However, a heater in a hermetically sealed enclosure which also complies with the aforementioned conditions may be used.

- The factory nameplate or duplicate must be affixed so that it can still be easily read when the heater is installed in the vehicle.
- All appropriate precautions must be taken when arranging the heater to minimise the risk of injuries to persons or damage to other property.

- **Fuel supply**

- The fuel intake connection must not be located in the passenger compartment and must be sealed with a properly closing lid to prevent any fuel leaks.
- In heaters for liquid fuel where the heater fuel is separate from the vehicle fuel, the type of fuel and intake connection must be clearly identified.
- A warning sign is to be fixed to the intake connection indicating that the heater must be switched off before refuelling.

- **Exhaust system**

- The exhaust outlet must be arranged so as to prevent any penetration of exhaust fumes into the vehicle interior through the ventilation system, warm air intakes or open windows.

- **Combustion air intake**

- The air for the heater's combustion chamber must not be sucked in from the vehicle's passenger compartment.
- The air intake must be arranged or protected in such a way that it cannot be blocked by other objects.

- **Automatic control of the heating system**

- If the engine fails, the heating system must be automatically switched off and the fuel supply stopped within 5 seconds. The heater may remain in operation if a manual device has already been activated.

Please note!

The heater is **not** approved for installation in the interior of Class M₁ vehicles (vehicles for passenger transport / cars) and N vehicles (vehicles for the transport of goods).

1 Introduction

Statutory regulations

Please note!

- Compliance with the statutory regulations, the additional regulations and the safety instructions is prerequisite for guarantee and liability claims. Failure to comply with the statutory regulations and safety instructions and incorrect repairs, even if original spare parts are used, make the guarantee null and void and preclude any liability for Eberspächer Climate Control Systems GmbH & Co. KG.
- Subsequent installation of this heater must comply with these installation instructions.
- The statutory regulations are binding and must also be observed in countries which do not have any special regulations.
- When installing the heater in vehicles not subject to the German Road Traffic Licensing Regulations (StVZO), for example ships, the respective specially valid regulations and installation instructions must be observed.
- Installation of the heater in special vehicles must comply with the regulations applying to such vehicles.
- Other installation requirements are given in the relevant sections of this manual.



1 Introduction

Safety instructions for installation and operation



Danger!

Risk of injury, fire and poisoning!

- Disconnect the vehicle battery before starting any kind of work.
- Before working on the heater, switch the heater off and let all hot parts cool down.
- The heater must not be operated in closed rooms, e.g. in the garage or in a multi-storey car park.



Important!

Safety instructions for installation and operation!

- The heater must only be installed by a JE partner authorised by the manufacturer according to the instructions in this manual and possibly according to special installation recommendations; the same applies to any repairs to be carried out in the case of repairs or guarantee claims.
- Repairs by non-authorized third-parties or with not original spare parts are dangerous and therefore not allowed. They result in expiry of the type-approval of the heater; consequently, when installed in motor vehicles they can cause expiry of the vehicle operating licence.
- The following measures are not allowed:
 - Changes to components relevant to the heater.
 - Use of third-party components not approved by Eberspächer Climate Control Systems GmbH & Co. KG.
 - Nonconformities in installation or operation from the statutory regulations, safety instructions or specifications relevant to safe operation as stated in the installation instructions and operating instructions. This applies in particular to the electrical wiring, fuel supply, combustion air system and exhaust system.
- Installation and repair may be carried out with original accessory parts and original spare parts only.
- Only control units approved by Eberspächer Climate Control Systems GmbH & Co. KG may be used to operate the heater. Use of other control units can cause malfunctions.

- Before the heater is installed again in another vehicle, rinse the heater parts carrying water with clear water.
- When carrying out electric welding on the vehicle, the positive cable at the battery should be disconnected and placed at ground to protect the control box.
- Do **not** operate the heater anywhere where there are readily flammable materials (e.g. dry grass, leaves, paper, etc.) in the area of the exhaust system or where ignitable fumes and dust can form, e.g. near a
 - fuel depot
 - coal depot
 - wood depot
 - grain depots, etc.
- The heater must be switched off when refuelling.
- If the heater is fitted in a safety casing, etc., the heater's installation box must not be used as storage space and must be kept clear. In particular fuel canisters, oil cans, spray cans, gas cartridges, fire extinguishers, cleaning rags, items of clothing, paper etc. must not be stored or transported on or next to the heater.
- Defect fuses must only be replaced by fuses with the prescribed rating.
- If fuel leaks from the heater fuel system, arrange for the damage to be repaired immediately by a JE service partner.
- When topping up the coolant, only use the coolant permitted by the vehicle manufacturer, see the vehicle operating manual. Any blending with unpermitted coolant can cause damage to the engine and heater.
- The after-running of the heater must not be prematurely interrupted e.g. by pressing the battery isolating switch, except for an emergency stop.

Please note!

Following installation, attach the "Switch off heater before refuelling!" sticker near the tank filler neck.

Accident prevention

General accident prevention regulations and the corresponding workshop and operating safety instructions are to be observed.

2 Product information

Scope of supply

Fig. No.	Designation	Order No.
1	Hydronic L16 – 24 volt	25 2486 02 00 00
1	Hydronic L24 – 24 volt	25 2487 02 00 00
2	Hydronic L24 – 24 volt Compact version	25 2487 05 00 00
1	Hydronic L30 – 24 volt	25 2599 02 00 00
2	Hydronic L30 – 24 volt Compact version	25 2599 05 00 00
1	Hydronic L35 – 24 volt	25 2600 02 00 00
2	Hydronic L35 – 24 volt Compact version	25 2600 05 00 00

The following additional parts are required to run the heater:

- Additional parts for connection to the water circuit
- Additional parts for the fuel supply
- Additional parts for the exhaust system
- Control unit

Additional parts which have to be ordered separately

Fig. No.	Designation	Order No.
3	Flowtronic 5000	25 2488 26 00 00
4	Flowtronic 5000S	25 1818 30 00 00
5	Flowtronic 6000 SC	25 2488 25 00 00
6	Hose clip, ø 40-47 mm	152 00 158
7	Hose elbow, ø 38 mm	360 00 300
8	Connection pipe, ø 38 mm	25 1214 89 00 21
9	T-piece, ø 38-38-38	25 1371 89 04 00
10	Reducer, ø 38/28 mm	25 1214 89 00 19
11	Hose clip, ø 32-39 mm	152 61 097
12	Pipe elbow, ø 38 mm	25 1214 89 00 03
13	Water hose, ø 38 mm	360 75 096
14	Exhaust pipe socket, ø 70 mm	22 1000 40 04 00
15	Exhaust pipe elbow, ø 70 mm	22 1000 40 03 00
16	Fuel filter	25 2488 05 01 00
17	Banjo bolt, M14 x 1.5	104 10 040
18	Sealing ring, A14 x 18	323 16 006
19	Fuel suction line, Ø 5 x 3, 800 mm long	25 2488 05 04 00
20	Screw fixing, M14 x 1.5	266 42 004
21	Spherical liner	263 35 080
22	Union nut, M14 x 1.5	116 10 040
23*	Fuel pipe, Cu, DIN 1786, inner diameter ø 6	-----
24	Fuel hose, inner diameter ø 5 x 3	360 75 350
25	Hose clip, ø 11 mm	10 2068 01 10 98
26	Screw fixing, M14 x 1.5	25 1706 05 01 00
27	Rubber buffer M6 x 10, height 15 mm	20 1607 65 00 02
28	Fuel return line, Ø 5 x 3, 750 mm long	25 1698 05 04 00
29	Ball valve	25 2488 05 02 00
30	Reducing coupling 8 / 6	266 00 026
31	Shroud with hose connection	22 1000 40 06 00
32	1 m flexible hose, ø 60 mm	10 2114 31 00 00
33	Hose clip	10 2064 05 00 70
34	Air hose fixing kit	22 1000 50 02 00
35	Plastic grille	25 1688 80 06 00

* The fuel pipe must be bought from the trade.

Please note!

For further additional parts, see product overview.



2 Product information

Scope of supply

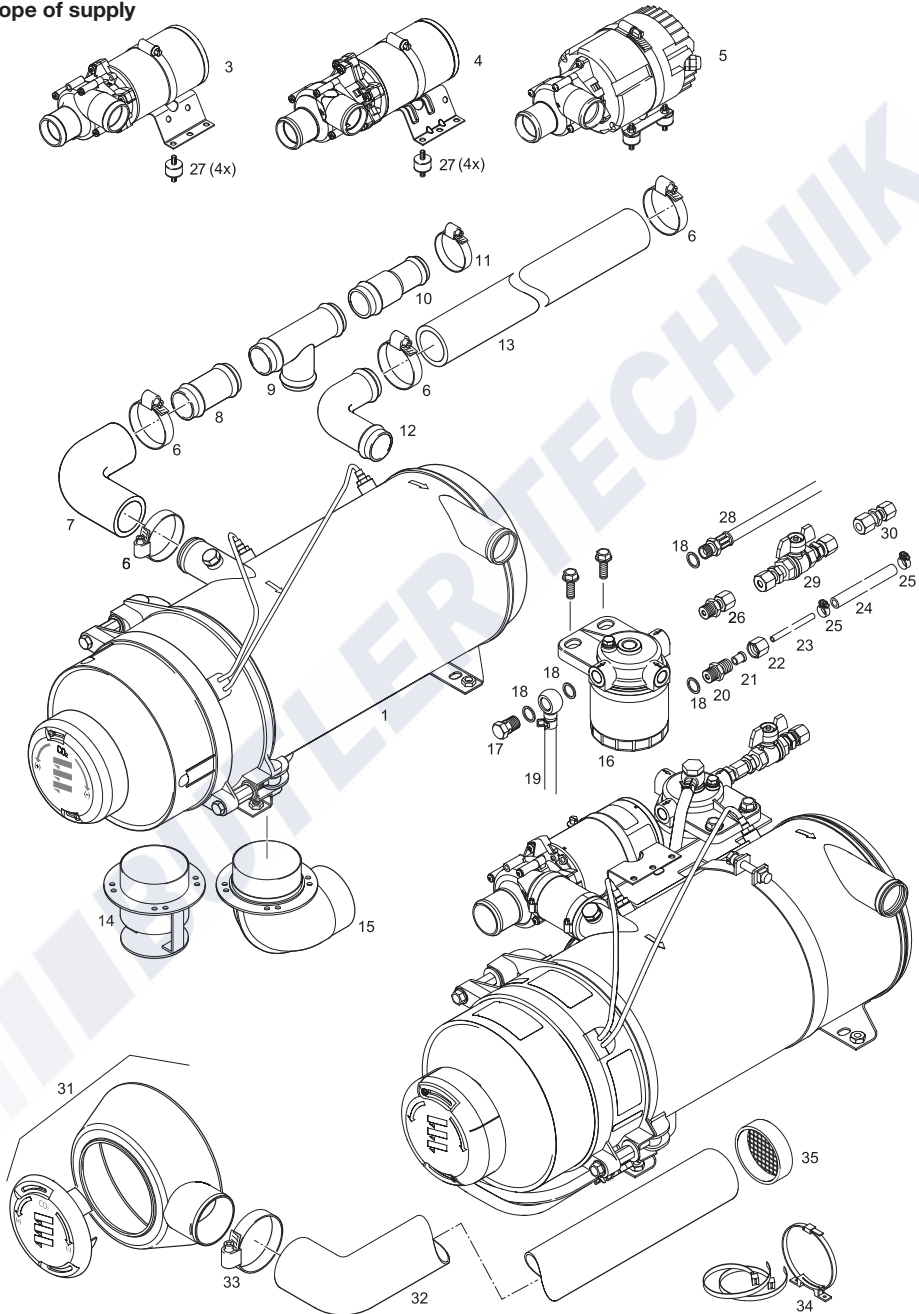

2 Product information

Technical data

Heater type	Hydronic L-II			
Heater	Hydronic L16	Hydronic L24	Hydronic L30	Hydronic L35
Version	HL2-16	HL2-24	HL2-30	HL2-35
Heating medium	Mixture of water and antifreeze (Proportion of antifreeze at least 10 % up to 50 % maximum)			
Heat flow in watts (at ambient temperature –10 °C)	16 000	24 000	30 000	35 000
Temperature values – at water inlet	ON 73 °C / OFF 78 °C			
Temperature values – at water outlet	ON 85 °C / OFF 118 °C			
Fuel	Diesel – commercially available (DIN EN 590) Heating oil EL (DIN 51603)			
Fuel consumption (at ambient temperature –10 °C)	2.0 l/h	2.9 l/h	3.65 l/h	4.2 l/h
Rated voltage	24 volt			
Operating range				
• Lower voltage limit: An undervoltage protection installed in the control box switches off the heater if the voltage limit is reached.	20 volt			
• Upper voltage limit: An overvoltage protection installed in the control box switches off the heater if the voltage limit is reached.	30 volt			
Electrical power consumption (in operation)	60 watt	80 watt	105 watt	120 watt
Water volume (in the heater)	approx 2.4 l			
Heating circuit water volume	min 10 l			
Minimum throughput (minimum at the heater)	1400 l/h	2000 l/h	2600 l/h	3000 l/h
Permissible ambient temperature	in operation		without operation	
Heater	–40 °C to +85 °C		–40 °C to +100 °C	
Permissible operating temperature				
Heating medium	–40 °C to +90 °C / briefly up to +120 °C			
Combustion air	< 60 °C			
Operating pressure (in the heater)	2.5 bar			
CO ₂ values (% vol)	9 – 11	9 – 11	9 – 11	9,5 – 11,5
CO in the exhaust	< 0,04			
Smoke spot no. (Bacherach)	< 4			
Weight	approx 18 kg			
Interference suppression class	4 for VHF / SW / LW, 5 for MW			
Protection	IP 54			



Important!

Safety instructions for technical data

Failure to comply with the technical data can result in malfunctions.

Please note!

Provided no limit values are given, the technical data provided is with the usual heater tolerances of ±10 % at rated voltage, 20 °C ambient temperature and reference altitude Esslingen.



2 Product information

Technical data

Pump type	Flowtronic 5000	
Heating medium	Mixture of water and antifreeze (Proportion of antifreeze at least 10 % up to 50 % maximum)	
Delivery rate	5200 l/h \pm 10 % at 0.2 bar delivery pressure	
Operating pressure, water circuit	max 2 bar	
Weight (without bracket, clip and coolant)	2.04 kg	
Rated voltage	24 volt	
Operating range	20 – 28 volt	
Power consumption at 5200 l/h and 0.2 bar delivery pressure	104 watt \pm 10 %	
Interference suppression class	Limit class 3 Interference field strength to CISPR25 3rd 0.15MHz – 1000 MHz to DIN 57879 / Part 1 VDE 0879	
Protection	IP 5K4	
Electrical fusing for third party controls	15 A	
Temperature conditions	Heating medium	-40 °C to + 90 °C short-term (15 min) +115 °C
	Ambient, operating	-40 °C to + 90 °C short-term (15 min) +115 °C
Dry running	No	
Blocking	The engine remains undamaged within a period of max 6 seconds.	
Shaft – impeller connection	Mechanical seal	



Important!

Safety instructions for technical data

Failure to comply with the technical data can result in malfunctions.

Please note!

- Provided no limit values are given, the technical data provided is with the usual water pump tolerances of \pm 10 % at rated voltage, 20 °C ambient temperature and reference altitude Esslingen.
- The Flowtronic 5000 water pump is installed in compact heaters.
- The water pumps must be assigned to the heaters depending on the minimum throughput and cooling water volume.

Pumping and pressure loss characteristic curves

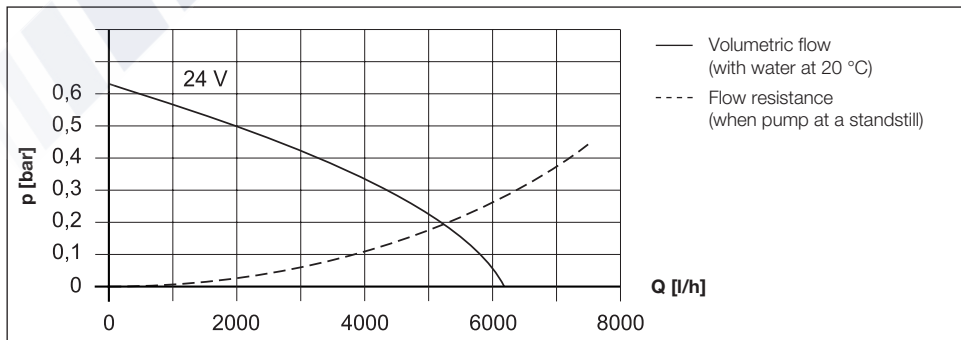

2 Product information

Technical data

Pump type	Flowtronic 5000 S	
Heating medium	Mixture of water and antifreeze (Proportion of antifreeze at least 10 % up to 50 % maximum)	
Delivery rate	5200 l/h ± 10 % at 0.2 bar delivery pressure	
Operating pressure, water circuit	max 2 bar	
Weight (without bracket, clip and coolant)	2.2 kg	
Rated voltage	24 volt	
Operating range	20 – 28 volt	
Power consumption at 5200 l/h and 0.2 bar delivery pressure	104 watt ± 10 %	
Interference suppression class	1 for VHF, 5 for SW, 2 for MW and LW to DIN 57879 / Part 1 VDE 0879	
Protection	IP 54A to DIN 40 050 Sheet 1	
Electrical fusing for third party controls	15 A	
Temperature conditions	Heating medium	–40 °C to +90 °C short-term (15 min) +115 °C
	Ambient, operating	–40 °C to +90 °C short-term (30 min) +115 °C
Dry running	No	
Blocking	The engine remains undamaged within a period of max 6 seconds.	
Shaft – impeller connection	Magnetic clutch	



Important!

Safety instructions for technical data

Failure to comply with the technical data can result in malfunctions.

Please note!

- Provided no limit values are given, the technical data provided is with the usual water pump tolerances of ± 10 % at rated voltage, 20 °C ambient temperature and reference altitude Esslingen.
- The water pumps must be assigned to the heaters depending on the minimum throughput and cooling water volume.

Pumping and pressure loss characteristic curves

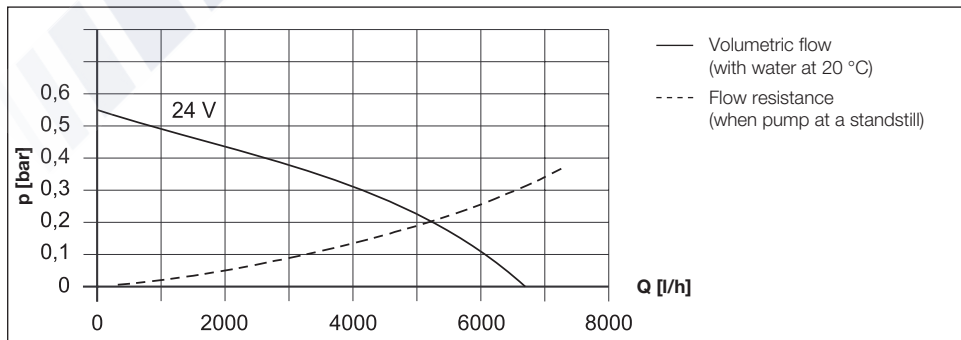



2 Product information

Technical data

Pump type	Flowtronic 6000 SC	
Heating medium	Mixture of water and antifreeze (Proportion of antifreeze at least 10 % up to 50 % maximum)	
Delivery rate	6000 l/h ± 5 % at 0.4 bar delivery pressure	
Operating pressure, water circuit	max 2 bar	
Weight (without bracket, clip and coolant)	2.5 kg	
Rated voltage	24 volt	
Operating range	18 – 32 volt	
Power consumption at 6000 l/h and 0.4 bar delivery pressure	210 watt ± 10 %	
Interference suppression class	5 for LW, MW, SW1, SW2, VHF according to DIN EN 55 025	
Protection	IP 25 (encapsulated electronics) according to DIN 40 050, Part 9	
Electrical fusing for third party controls	15 A	
Temperature conditions	Heating medium	-40 °C to + 90 °C short-term (15 min) +115 °C
	Ambient, operating	-40 °C to + 90 °C short-term (15 min) +100 °C
	Storage	-40 °C to + 120 °C
Dry running	approx 45 min. – the motor switches itself off after approx 45 min.	
Anti-blocking protection	Yes – the starting attempts are continued without limit.	



Important!

Safety instructions for technical data

Failure to comply with the technical data can result in malfunctions.

Please note!

- Provided no limit values are given, the technical data provided is with the usual water pump tolerances of ± 10 % at rated voltage, 20 °C ambient temperature and reference altitude Esslingen.
- The water pumps must be assigned to the heaters depending on the minimum throughput and cooling water volume.

Pumping and pressure loss characteristic curves

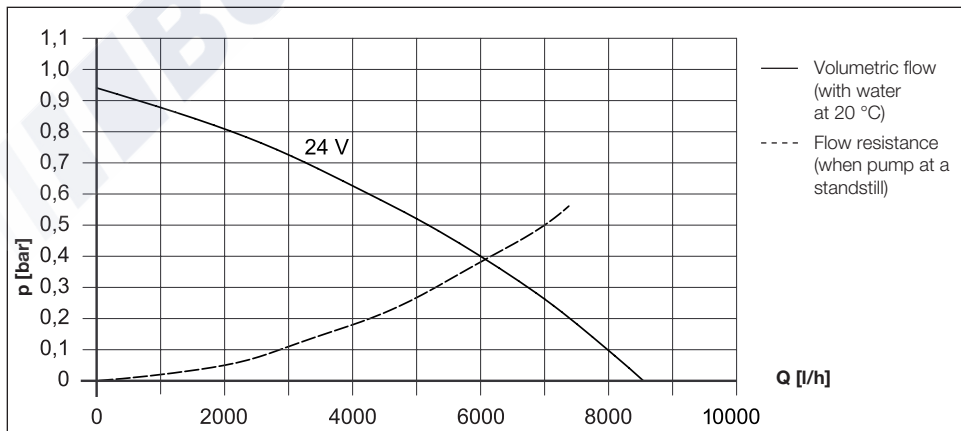

2 Product information

Main dimensions

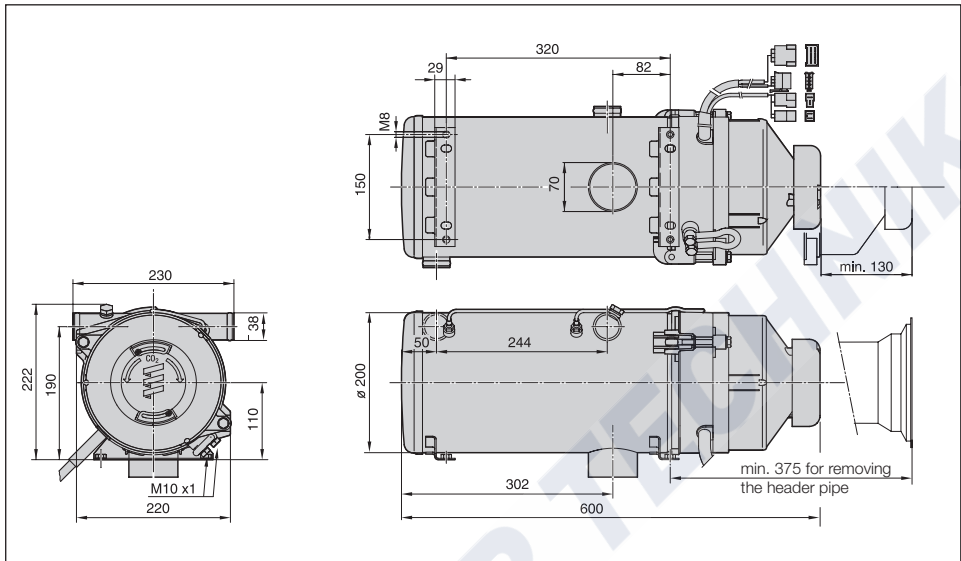

Main dimensions – compact version

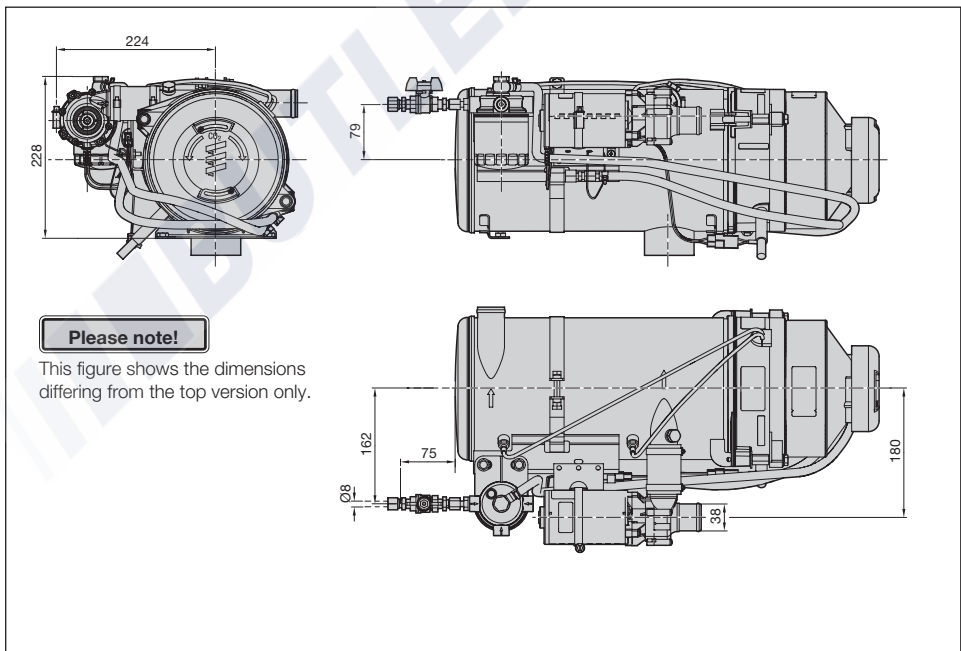



3 Installation

Permissible mounting positions and fastening of the heater

The heater should preferably be installed in a horizontal position.

Transfer the four fastening holes and the through hole for the exhaust fitting onto the mounting surface – as shown in the sketch – and drill accordingly.

Fix the heater with 4 screws M8 and 4 body washers.

Please note!

- The contact surface for the two fastening consoles must be flat.
- Depending on the installation conditions, the heater can be tilted at an angle as shown in the diagrams. In heating mode, the heater can deviate from the normal position by up to +15° in all directions as a result of the slanted position of the vehicle.
- For vertical mounting position the heater must always be supported at the bottom of the heat exchanger by a stable bearing surface. The fixing screws are solely for fixing the heater.

Permissible mounting positions and hole pattern for the heater

- Horizontal mounting position with the allowable deviations.
- Vertical mounting position without deviations.

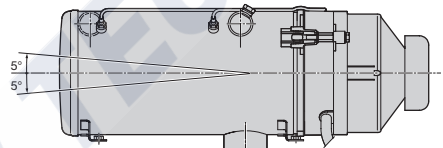
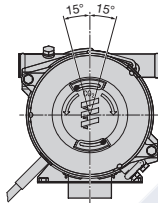

Drilling hole pattern

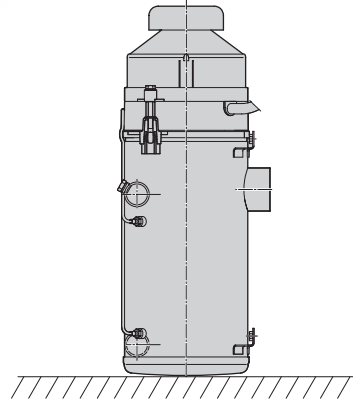
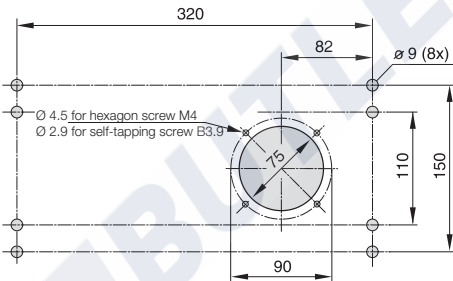

Mounting position, compact version

- Horizontal mounting position with the allowable deviations.
- Vertical mounting position **not** allowed.

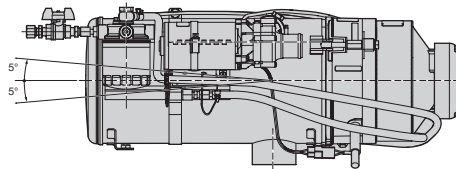
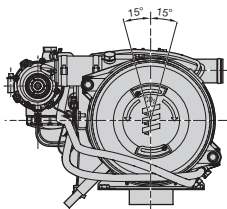

3 Installation

Main dimensions, Flowtronic 5000

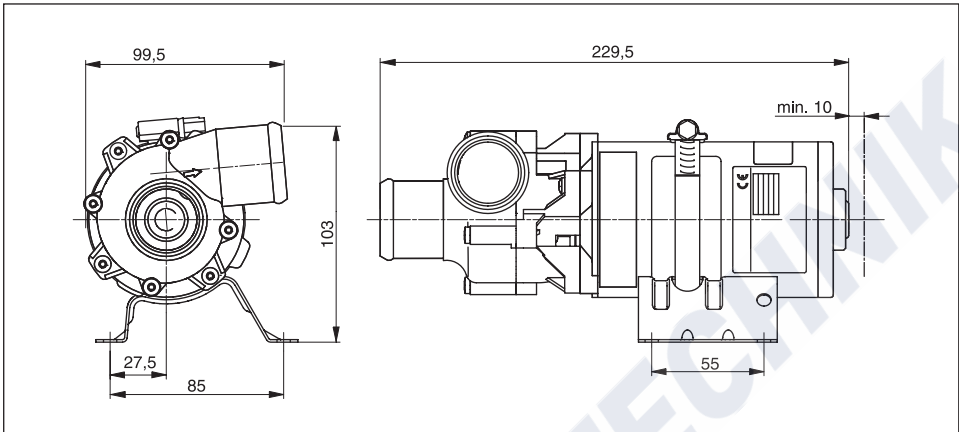

Permissible mounting positions and fastening of the water pump

The water pump is installed in a horizontal position. In this horizontal position, the water pump with its pump housing can be rotated – as shown in the sketch below. Transfer the four fastening holes onto the mounting surface – as shown in the sketch of the main dimensions – and drill accordingly.

If possible, fix the water pump to the vehicle with 4 rubber buffers M6 x 10.

Please note!

- The laying of the connection lines must not cause any lateral strain forces to occur in the inlet and outlet connection sockets of the water pump (the connection sockets and connection lines must be in alignment).
- The installation clearance from adjacent components must be at least 10 mm.
- Contact the manufacturer for installation in a different position.

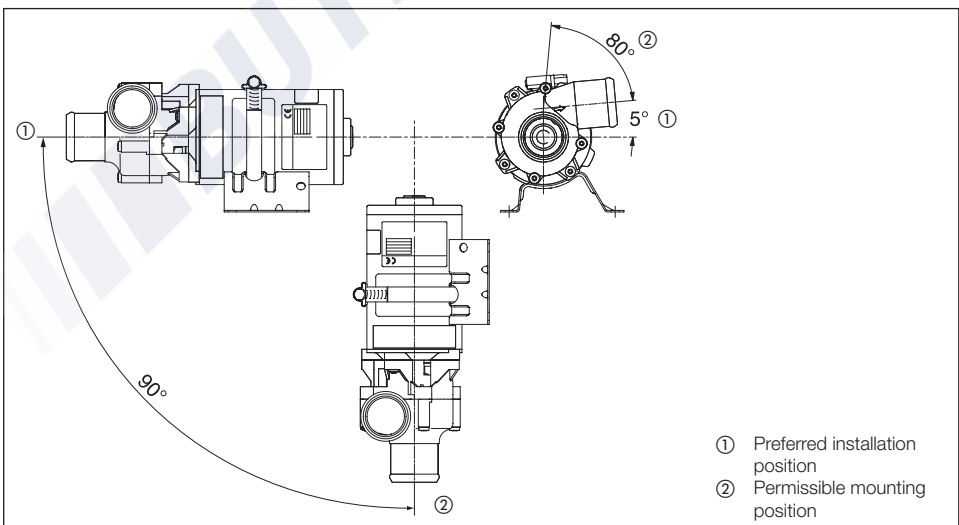

- ① Preferred installation position
- ② Permissible mounting position



3 Installation

Main dimensions, Flowtronic 5000 S

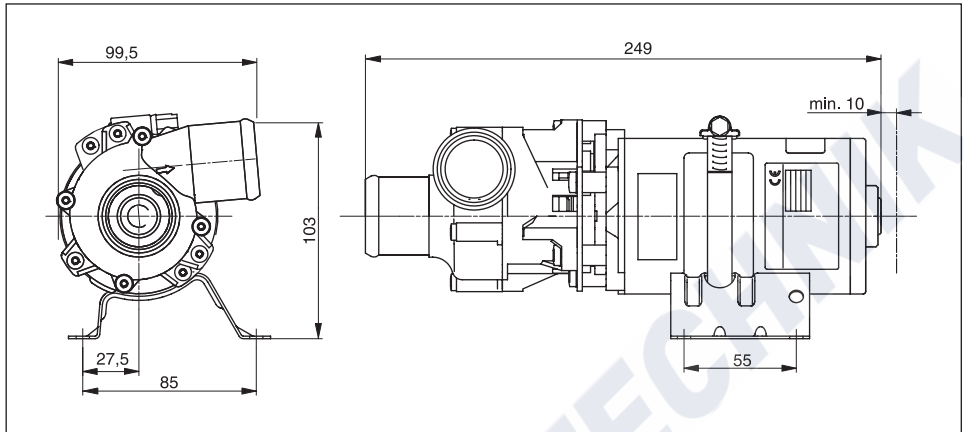

Permissible mounting positions and fastening of the water pump

The water pump should preferably be installed in a horizontal position.

Transfer the four fastening holes onto the mounting surface – as shown in the sketch of the main dimensions – and drill accordingly.

If possible, fix the water pump to the vehicle with 4 rubber buffers M6 x 10.

Please note!

- The laying of the connection lines must not cause any lateral strain forces to occur in the inlet and outlet connection sockets of the water pump (the connection sockets and connection lines must be in alignment).
- The installation clearance from adjacent components must be at least 10 mm.

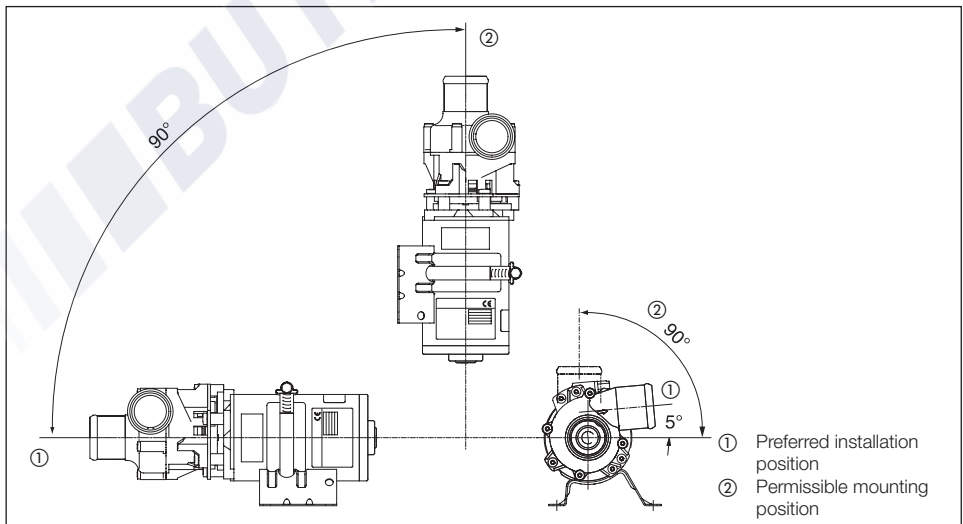

- ① Preferred installation position
- ② Permissible mounting position

3 Installation

Main dimensions, Flowtronic 6000 SC

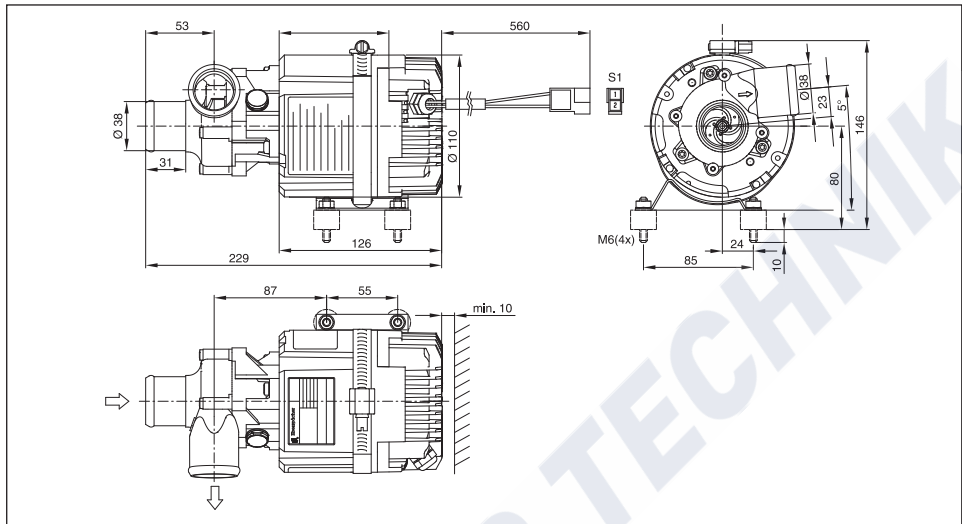

Permissible mounting positions and fastening of the water pump

The water pump should preferably be installed in a horizontal position.

Transfer the four fastening holes onto the mounting surface – as shown in the sketch of the main dimensions – and drill accordingly.

Fix the water pump to the vehicle using the M6 rubber buffers included in the scope of supply.

Please note!

- The mounting position of the water pump must be chosen to prevent large quantities of water or exhaust gas from entering the electric motor.
- The laying of the connection lines must not cause any lateral strain forces to occur in the inlet and outlet connection sockets of the water pump (the connection sockets and connection lines must be in alignment).
- The distance from adjacent parts must be at least 10 mm to ensure ventilation.

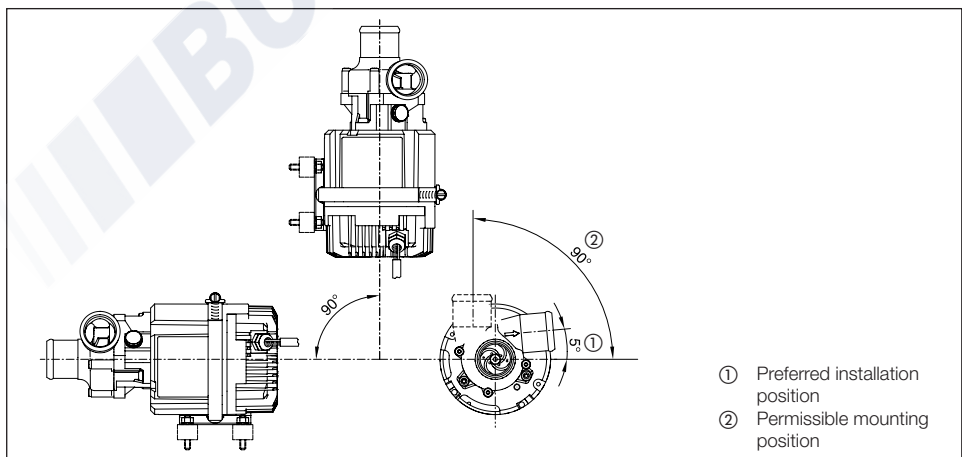

- ① Preferred installation position
- ② Permissible mounting position



3 Installation

Installation location

The heater and the water pump are integrated in the cooling water circuit of the vehicle or in a separate water circuit.

The heater should be installed as low as possible in the vehicle, in a splash-proof position, e.g. in the engine compartment or in a stowage compartment. This ensures automatic venting of the heater and the water pump.

When choosing the mounting position, space must be left to dismantle the shroud (130 mm) and the header pipe (375 mm).

Breakthroughs to the outside must be splashproof.

If the installation conditions are too cramped, or if the temperature is excessively high, a hood with hose connection must be installed for combustion air intake. The combustion air is then drawn in through a flexible hose. This enables the combustion air to be drawn in from

an area with an allowable temperature range which is protected from dirt.

A safety grille is to be fitted to the flexible hose. After installing a hood with hose connection, the combustion air must be adjusted by measuring the CO₂ level. Please refer to the troubleshooting section and repair instructions for the set values.

Other installation locations are possible if they comply with the installation requirements stated in these installation instructions.

Additional notes on the location in rail vehicles

In rail vehicles the heater must be fixed in the engine compartment (e.g. locomotive) or under floor in the installation box on the vehicle body (e.g. railcar).

Other locations require an acceptance inspection by Eberspächer Climate Control Systems GmbH & Co. KG.

Installation example in a bus and in a rail vehicle

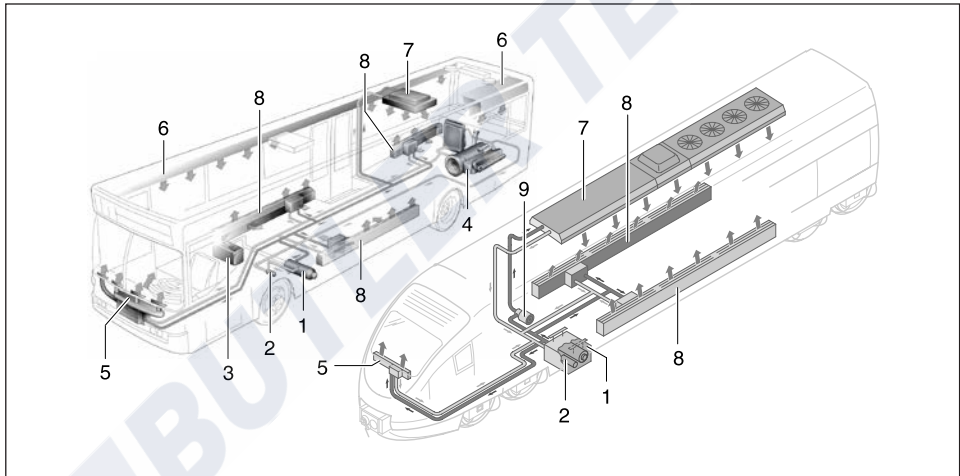

- | | | |
|-------------------|------------------|-------------------------|
| 1 Heater | 4 Vehicle engine | 7 Roof heater |
| 2 Water pump | 5 Front heater | 8 Floor heater |
| 3 Tank connection | 6 Roof air ducts | 9 Additional water pump |

Please note!

- Comply with the statutory regulations and safety instructions regarding the contents of this chapter on page 4 – 7.
- Mount the heater under the minimum cooling water level (header tank, radiator, vehicle heat exchanger).
- If installing the heater in a separately installed water circuit the installation must always be subjected to an acceptance inspection by the heater manufacturer.

If this installation acceptance does not take place any warranty or liability claims whatsoever expire.

- It is **not** permissible to fix the heater in rail vehicles with metal-rubber buffers.
- Installation requirements (e.g. for boats and ships) are available from the manufacturer on request.

3 Installation

Installing the heater in a box

If the heater cannot be installed in the engine compartment or in a stowage compartment of the vehicle, it can also be installed in a box.

The box with the installed heater is then fixed to the vehicle at a suitable point e.g. longitudinal frame.

It is necessary to install a hood with hose connection for combustion air intake.

The combustion air is then drawn in from outside the box through a flexible hose.

This enables the combustion air to be drawn in from an area with an allowable temperature range which is protected from dirt.

A safety grille is to be fitted to the flexible hose. After installing a hood with hose connection, the combustion air must be adjusted by measuring the CO₂ level. Please refer to the troubleshooting section and repair instructions for the set values.

Installation example – heater in a box

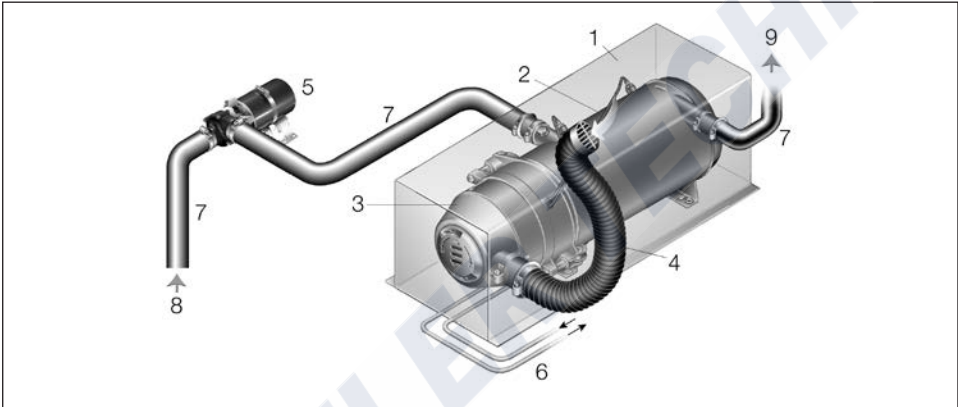

- 1 Box
- 2 Heater
- 3 Shroud with hose connection
- 4 Flexible hose with safety grille
- 5 Water pump
- 6 Fuel lines
- 7 Water hose
- 8 Water inlet
- 9 Water outlet

Please note!

- Comply with the statutory regulations and safety instructions regarding this chapter on page 4 – 7.
- The box must be adequately ventilated from the outside so that the permissible ambient temperature is not exceeded.
- Ventilation openings must be positioned in the box in such a way that they cannot be clogged up by dirt and snow.
- Any water which penetrates the box must be allowed to drain off.



3 Installation

Nameplate

The nameplate stuck onto the heater must be protected against damage and must be easy to read when the heater is installed. If this is not the case the installer can stick a duplicate nameplate onto the heater or in the area of the heater in a position in which it is easy to see and read.

The duplicate nameplate is glued onto the shroud of the heater, and can be pulled off if necessary.

Please note!

- Comply with the statutory regulations and safety instructions regarding this chapter on page 5 – 7.
- Heaters approved for installation in rail vehicles are identified by an EBA No. on the nameplate.

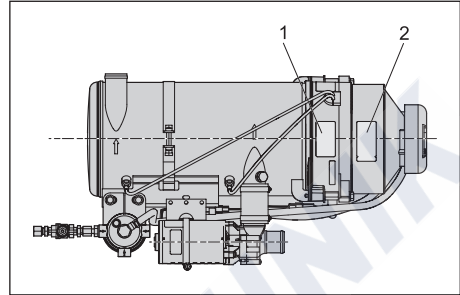

- 1 Original nameplate
- 2 Duplicate nameplate

3 Installation

Exhaust system (pipes)



Danger!

Risk of injuries and burns!

Every type of combustion produces high temperatures and toxic exhaust fumes. This is why the exhaust system must always be laid according to these installation instructions.

- Do not perform any work on the exhaust system while the heater is working.
- Before working on the exhaust system, switch off the heater first and wait until all the parts have completely cooled down, wear safety gloves if necessary.
- Do not inhale exhaust fumes.



Important!

Safety instructions for the exhaust system!

- The exhaust pipe must end in the open air.
- The exhaust pipe must not protrude beyond the lateral limits of the vehicle.
- Install the exhaust pipe sloping slightly downwards, if necessary drill a drain hole approx \varnothing 5 mm at the lowest point as a condensation outlet.
- Important functional parts of the vehicle must not be impaired (keep sufficient clearance).
- Install the exhaust pipe with sufficient clearance from heat-sensitive components. Pay particular attention to fuel lines (made of plastic or metal), electrical cables and brake hoses, etc.!
- Exhaust pipes must be safely fixed (recommended clearance of 50 cm) to avoid damage from vibrations.
- Lay the exhaust system so that the outflowing exhaust gases are not sucked in as combustion air.
- The mouth of the exhaust pipe must not become clogged with dirt and snow.
- Align the outlet of the exhaust pipe so that the discharge of the exhaust is not prevented by backpressure (wind/airstream). Backpressure increases the temperature in the heat exchanger and causes component damage.
- In rail vehicles it is important to ensure that the exhaust opening does not point in one of the possible directions of travel (90° to the direction of travel).

Installing the exhaust system

Push an exhaust pipe elbow or an exhaust pipe socket onto the heater's exhaust connection and fix to the floor of the vehicle.

Order No. of the exhaust system parts, see page 8.

A rigid or flexible exhaust pipe, inner \varnothing 70 mm, can be fixed to the exhaust bend as an extension. The exhaust pipe can be up to a maximum of 4 m long, depending on the installation conditions.

A rigid exhaust pipe made from unalloyed or alloyed steel or a flexible exhaust pipe made from alloyed steel, inner \varnothing = 70 mm, is currently not available.

If needed the exhaust pipe and the corresponding pipe clips must be purchased from a specialist store; the wall thickness of the rigid exhaust pipe must be at least 1 mm.

After the exhaust system has been installed, make an end sleeve (see page 17) and push it onto the end of the exhaust pipe.

Please note!

- The exhaust system can be laid with max. $3 \times 90^\circ$ angles, the total length reduces by 0.5 m with each 90° -bend.
- Use pipe clips to fix the exhaust pipe to the vehicle floor at suitable places.
- Comply with the statutory regulations and safety instructions regarding this chapter on page 4 – 7.



3 Installation

Exhaust system (pipes)

Example for the exhaust system

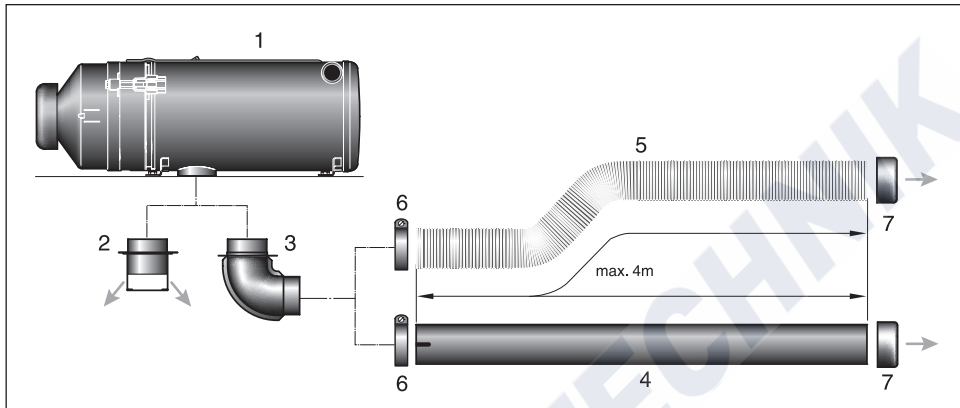

Sketch 1

- 1 Heater
- 2 Exhaust connection
- 3 Exhaust pipe elbow 90°
- 4 Exhaust pipe
- 5 Flexible exhaust pipe
- 6 Pipe clip
- 7 Metal end sleeve

Please note!

Items 4 – 6 must be purchased from a specialist store.
You must make Item 7 yourself.

Metal end sleeve with separators for exhaust pipe

If necessary you must make a metal end sleeve with separators for the exhaust pipe yourself.
The metal end sleeve must not plug the exhaust so that soot is formed.

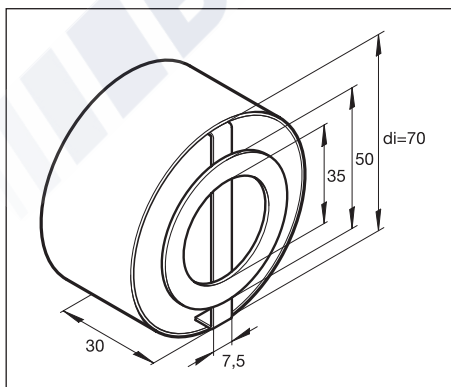

3 Installation

Combustion air system



Important!

Safety instructions for the combustion air system!

- The combustion air may not be drawn in from rooms in which there are people.
- The combustion air opening must be free at all times.
- Position the combustion air intake to be sure that exhaust fumes cannot be sucked in with the combustion air.
- Do not direct the combustion air intake against the vehicle's airstream.
- The combustion air intake must not become clogged with dirt and snow.
- Install the combustion air system sloping slightly downwards. If necessary, make a drain hole approx. \varnothing 5 mm at the lowest point as a condensation outlet.
- If the heater is installed near the vehicle's tank in a joint installation space the combustion air must be drawn in from the outside and the exhaust must be discharged outside into the open air. The openings must be made splashproof.
- In rail vehicles it is important to ensure that the combustion air opening does not point in one of the possible directions of travel (90° to the direction of travel).

Please note!

Comply with the statutory regulations and safety instructions regarding this chapter on page 4 – 7.

Combustion air intake

The combustion air is routed to the burner in the heater via the hood. No installation work is necessary. If the heater is installed in a box or the installation conditions are very confined and/or the temperature is unacceptably high, we recommend fitting a hood with hose connection for drawing in the combustion air. The combustion air is then sucked in through a flexible hose. This ensures that the combustion air is sucked in from an area in the right temperature range which is protected from dirt. A safety grille is to be fitted to the flexible hose.

If a hood with hose connection is not used when the heater is installed in a box, the combustion air must be sucked in through a ventilation opening with an effective minimum cross section which corresponds to a pipe with \varnothing 60 mm.

Please note!

The ventilation opening for the combustion air must be positioned on the box so that it cannot become blocked by dirt and snow and exhaust gases cannot be sucked in.

Example for the combustion air system

Combustion air intake through a gill plate.

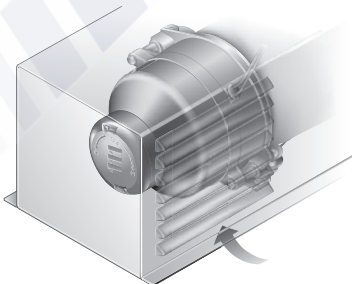

Combustion air intake with a flexible hose \varnothing 60 mm, max 1 m long.

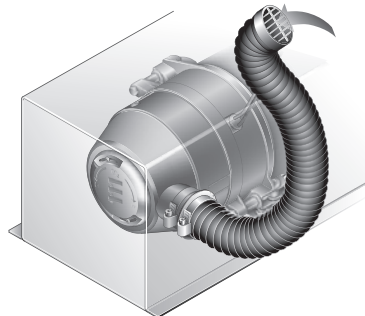



3 Installation

Connection to the cooling water circuit

The heater is integrated in the vehicle's cooling water circuit.

An alternative installation option is to install the heater with its own cooling water circuit with a header tank.



Danger!

Risk of injuries and burns!

The cooling water and components of the cooling water circuit can get very hot.

- Parts conveying water must be routed and fastened in such a way that they pose no temperature risk to man, animals or material sensitive to temperature from radiation / direct contact.
- Before working on the cooling water circuit, switch the heater off and wait until all the components have cooled down completely, if necessary wear safety gloves.

Please note!

- When installing the heater, please note the direction of flow of the cooling water circuit.
- The water hoses included in the Eberspächer Climate Control Systems GmbH & Co. KG scope of supply must be used. If not, the hoses used must at least conform to DIN 73411.
- Fill the heater and water hoses with cooling water before connecting to the cooling water circuit.
- Route the water hoses without any kinks, and in a rising position if possible.
- When routing the water pipes, observe a sufficient clearance to hot vehicle parts.
- Protect all water hoses / water pipes from chafing and from extreme temperatures.

- Secure all hose connections with hose clips.
- After the vehicle has been operating for 2 hours or travelled 100 km, tighten the hose clips again.
- The minimum water flow rate is only guaranteed if the temperature difference of the heating medium does not exceed 10 K between water inlet and water outlet during heating.
- Only overpressure valves with an opening pressure of min. 0.4 – max. 2 bar may be used in the cooling water circuit.
- As corrosion protection the cooling water must contain at least 10 % antifreeze the whole year round.
- During cold periods the coolant water must contain sufficient coolant (antifreeze).
- Before commissioning the heater for the first time or after changing the cooling water, the whole cooling water circuit including the heater must be vented with-out bubbles according to the vehicle manufacturer's instructions.
- Correct ventilation is identifiable by a water pump which operates virtually noise-free. Poor ventilation can result in overheating of the resettable thermal cut-out in heating mode.
- Only top up with coolant approved by the vehicle manufacturer.
- Insert the water pump preferably in the water inlet line to the heater.
- Match the heater and the cooling water circuit so that a cooling water temperature of at least 60 °C can be reached within half an hour, as otherwise the heat exchanger produces too much condensation and therefore reduces the efficiency.

Installation example

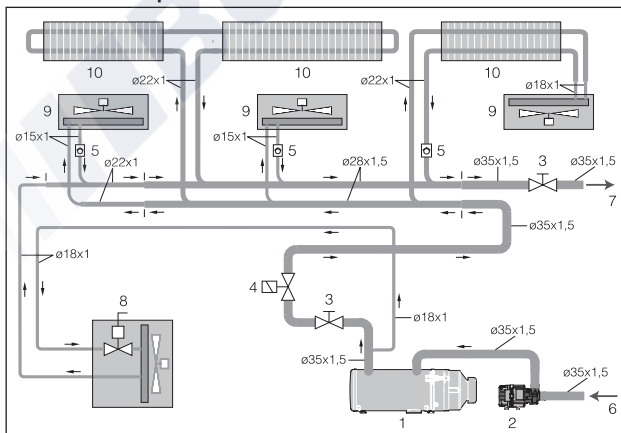

Water circuit

In this installation example, the heater is shown integrated in the cooling water circuit of a coach/rail vehicle.

- 1 Heater
- 2 Flowtronic water pump
- 3 Shutoff valve
- 4 Electrical shutoff valve
- 5 Non-return valve
- 6 From vehicle engine or header tank
- 7 To the vehicle engine or header tank
- 8 Front heater / driver's cab
- 9 Space heater
- 10 Convection heater

3 Installation

Fuel supply

The fuel is taken from the vehicle's fuel tank or a separate fuel tank.

The following safety instructions must always be observed when laying the fuel lines and installing a fuel tank.

Deviations from the instructions stated here are not allowed.

Failure to comply can result in malfunctions.



Danger!

Risk of fire, explosion, poisoning and injuries!

Caution when handling fuel.

- Switch off the vehicle engine and the heater before refuelling and before working on the fuel supply.
- Avoid naked flames when handling fuel.
- Do not smoke
- Do not inhale petrol fumes.
- Avoid any contact with the skin.



Important!

Safety instructions for laying the fuel pipes!

- Use a sharp knife only to trim the fuel hoses and pipes. Interfaces must not be crushed and must be free of burrs.
- The intake and return line must be filled with fuel when putting into service. The heater only works with vented pipes and filter.
- Fuel pipes must be securely fixed to avoid any damage and / or noise due to vibrations (recommended guideline value: at spacings of approx. 50 cm).
- Fuel pipes must be protected against mechanical damage.
- Lay the fuel pipes so that any distortion or shaking of the vehicle, engine movements, etc. do not have a disadvantageous effect on the service life.
- Parts carrying fuel must be protected from disruptive heat.

- Never lay or fix the fuel pipes immediately next to the heater's exhaust system pipes or along the vehicle's exhaust system. If the systems cross, always ensure there is sufficient heat clearance. If necessary, install heat deflection plates.
- Dripping or evaporating fuel must never be allowed to collect on hot parts or ignite on electric equipment.
- When connecting fuel pipes with a fuel hose, always mount the fuel pipes in a butt joint to prevent any bubbles from forming.

Safety instructions for fuel pipes and fuel tanks in buses and coaches

- In buses and coaches, fuel pipes and fuel tanks must not be routed through the passenger compartment or driver's cab.
- Fuel tanks in buses and coaches must be positioned in such a way that the exits are not in immediate danger if a fire occurs.

Please note!

Comply with the statutory regulations and safety instructions regarding this chapter on page 4 – 7.



3 Installation

Fuel supply

Fuel quality

- The heater runs problem-free on standard commercial grade diesel fuel according to DIN EN 590. During the winter months the diesel fuel is adapted to the low temperatures of 0 °C to –20 °C. Problems can therefore only arise at extremely low outdoor temperatures – as is the case with the vehicle engine – please refer to the vehicle manufacturer's instructions.
- In special cases and at outdoor temperatures above 0 °C the heater can also be run on EL heating oil according to DIN 51603.
- If the heater is run from a separate tank, please comply with the following rules:
 - at outdoor temperatures over 0 °C:
Use diesel fuel according to DIN EN 590.
 - at outdoor temperatures of 0 °C to –20 °C:
use winter diesel fuel according to DIN 590.
 - at outdoor temperatures –20 °C to –40 °C:
Use Arctic diesel or Polar diesel.

Please note!

- Additions of used oil are **not** allowed!
- After refuelling with winter or cold weather diesel the fuel lines must be filled with the new fuel by letting the heater run for 15 minutes!

Operation with biodiesel (FAME)

The heaters are **not** approved for operation with bio-diesel fuel (FAME according to DIN EN 14 214).

3 Installation

Fuel supply

Connection of the intake and return pipe to the heater

If fuel hoses are used, the hoses offered in the Eberspächer Climate Control Systems GmbH & Co. KG product range should always be used.

If not, the fuel hoses must at least conform to DIN 73379-1, Type 3.

Fire-resistant fuel hoses to EN ISO 7840 must be used for marine vessels.

If using metal fuel pipes, the usual materials for vehicle construction such as copper or steel must be used, together with the respective appropriate sealing and connection technique.

If using plastic pipes, they must conform to DIN 73378 (made from soft, light and temperature stabilised PA 11 or PA 12) and must be installed together with the respective appropriate connection technique

Permissible dimensions of the fuel lines

Inner diameter of the suction and return line:

- for connection to the ring hose nipple \varnothing 6 mm:
min \varnothing 5 mm / max \varnothing 6 mm,
- **Special case** – for connection to the ring hose nipple \varnothing 8 mm: min \varnothing 7 mm / max \varnothing 8 mm.

Important!

Installation for a shut-off device in the return line is **not** allowed!

Please note!

- Fuel hoses and fuel pipes are available as additional parts, see product overview.
- Fuel lines with inner diameter \varnothing 7 mm / \varnothing 8 mm as well as ring hose nipple with \varnothing 8 mm must be purchased from the trade.

Functional performance of the heater depending on the underpressure in the fuel system

In order to ensure the fuel pump works properly, it is necessary to ensure that the underpressure in the fuel system is not too high (see table).

	Fuel pressure (P) Heater inlet	Fuel pressure (P) Filter inlet
Preferred range *	min -0.3 bar	min -0.2 bar
Allowable range **	-0.45 bar to -0.3 bar	-0.35 bar to -0.2 bar
Critical range ***	-0.55 bar to -0.45 bar	-0.45 bar to -0.35 bar
Heating mode not possible	< -0.55 bar	< -0.45 bar

* Preferred range for design of the fuel supply

** Over the operating period the counterpressure in the fuel supply can increase as a result of deposits (filter clogs up).

*** Heater becomes susceptible to faults (gas bubble formation / fault code 52, 54)

Permissible suction height and lengths of the suction line (min. \varnothing 5 mm up to max. \varnothing 8 mm):

- Suction height up to 1.5 m → max. length = 25 m
- Suction height 1.5 m to 4.0 m → max. length = 15 m

Permissible length of the return line (min. \varnothing 5 mm up to max. \varnothing 8 mm):

- max. length = 18 m

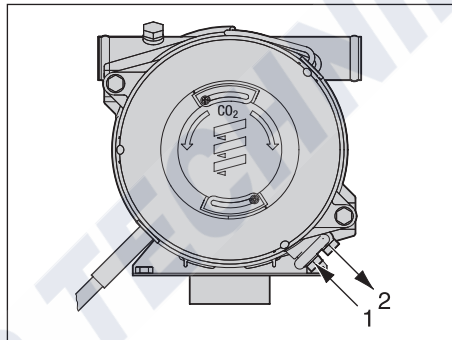

- 1 Connection of the suction line to the ring hose nipple \varnothing 6 mm
- 2 Connection of the return line to the ring hose nipple \varnothing 6 mm



4 Operation and function

Structure of the heater

The heater consists of a heat exchanger and a removable burner. The heat exchanger contains a combustion chamber consisting of a header pipe with integrated mixer. The header pipe can be pulled out of the heat exchanger if necessary.

The control box and electric motor are fixed to the burner flange under the shroud of the burner. The fuel pump is integrated in the burner housing.

The following additional parts are required to run the heater:

- Water pump
 - already installed in compact version
- Additional parts for connection to the water circuit
- Additional parts for the fuel supply
- Additional parts for the exhaust system
- Control unit

For order No. of the additional parts, see page 8, for further additional parts, see product overview.

Operating instructions

The heater is operated by a control unit. Detailed operating instructions are supplied with the control unit.

Please note!

You will be issued the operating instructions by the installation workshop.

Important notes on operation

Perform safety checks before the start

After a lengthy stoppage (summer months), check all components for secure fit (tighten screws where necessary).

Carry out a visual check of the fuel system for leaks.

Before switching on

Before switching on or pre-programming heating mode, switch the vehicle's heating lever to "WARM" (maximum setting) and the blower to "slow level" (lower electricity consumption). In vehicles with automatic heating, before switching off the ignition, switch the heating lever to "MAX" and the required damper position to "OPEN".

Heating at high altitudes

When using the heater at high altitudes, please note:

- Heating at altitudes up to 1500 m:
 - Unlimited heating possible.
- Heating at altitudes over 1500 m:
 - You can use the heater at this altitude for short periods (e.g. driving through a mountain pass or taking a break in your journey).
 - For longer stays it is necessary to adjust the level of the fuel supply, please contact a JE partner for further details and advice.

Initial commissioning of the heater

The following points are to be checked by the company installing the heater during initial commissioning.

- Ensure you read the operating and maintenance instructions before starting up the heater.
- After installation of the heater, the coolant circuit and the whole fuel supply system must be vented carefully. Comply with the instructions issued by the vehicle manufacturer.
- Open the coolant circuit before the trial run (set the temperature control to "WARM").
- During the heater trial run, all water and fuel connections must be checked for leaks and secure, tight fit.
- If faults occur while the heater is running, use a diagnostic unit to determine and correct the cause of the fault.

4 Operation and function

Functional description

Switch on the heater

When the heater is switched on a component test is performed (3 seconds), the water pump is then started up.

Note:

The nozzle pre-heater is switched on the first time the heater is switched on.

- In the Hydronic L16 / L24, the nozzle pre-heater remains switched on until the heater switches "OFF" or is switched off beforehand.
- In the Hydronic L30 / L35, the operating time of the nozzle pre-heater is limited to 15 min.

Burner start

The electric motor starts and drives the combustion air impeller and the fuel pump.

After approx 10 seconds the ignition is switched on and then the fuel solenoid valve opens. Within these 10 seconds a rotary check is performed on the electric motor. The fuel and combustion air in the combustion chamber form an ignitable mixture.

The mixture is ignited by a high-voltage ignition spark. The flame monitor recognises the flame's flicker frequency and switches off the ignition spark generator. The hot combustion gases flow through the heat exchanger and transfer the heat to the heat distribution medium.

Please note!

- The heater operates depending on the heat requirements, this means the burner's switching on and switching off times vary.
- The water pump remains in service the whole time the heater is running, even during pause mode and during after-running.

Options

- If temperature lowering is activated the "ON / OFF" control temperatures are lowered by approx 8K. Connection of the ON / OFF - switch for temperature lowering, see circuit diagram on page 34.
- The water pump can be run independently of the heater if appropriate controls are installed. For connection of the additional "ON / OFF" switch for separate water pump control, see circuit diagram on page 34.
- With control of the vehicle's blower, the vehicle blower is switched on or off at the following water temperatures.
 - Water temperature > 55 °C
→ Vehicle blower "ON"
 - Water temperature < 50 °C
→ Vehicle blower "OFF"

For control of the vehicle's blower, see circuit diagram on page 34.

Functional diagram

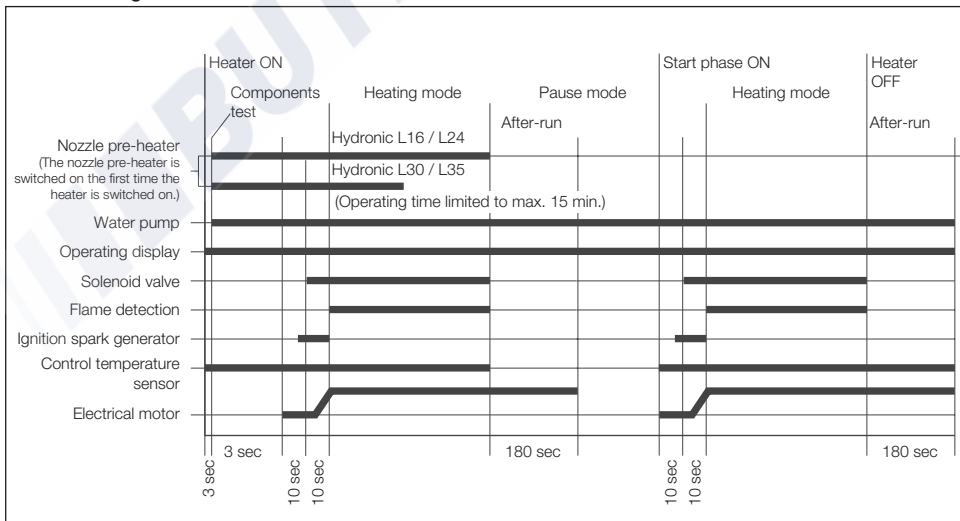



4 Operation and function

Switch off the heater

If the heater is switched off the fuel solenoid valve closes and after-running simultaneously starts for approx 3 minutes.

After the after-running has finished the heater is automatically switched off.

Please note!

Until it is switched off, including during the after-running, the fuel is circulated.

Control and safety devices

The heater is equipped with the following control and safety devices.

- If the heater does not ignite the control box* is locked after an unpermissible number of unsuccessful start attempts.
 - If the water flow is too low the water discharge temperature is limited by premature compensation.
 - The time taken for the temperature rise in the heat distribution medium is monitored. If it rises too fast (water flow too low) the heater automatically switches "OFF" and begins with the after-running, the cycle then begins again.
 - Constant comparison of the temperature sensor and overheating sensor measured values provides additional heater safety, because if the difference between the measured values is too large (water flow too low) the heater is prematurely switched off (shut-down on fault).
After an impermissible number of shut-downs on fault, the control box is locked.*
 - If the lower or upper voltage limit is reached, the heater is automatically switched off.
 - If the flame sensor detects a flame during the heater's after-running the heater is automatically switched off. After an impermissible number of shut-downs on fault, the control box is locked.*
- * The control box can be unlocked with testing equipment / a control unit. For the procedure and description for testing equipment and control units, see "Installation Instructions Plus – EasyStart/Altitude Kit / Special Functions and Diagnosis"

Emergency stop – EMERGENCY OFF

If an emergency stop – EMERGENCY OFF – is necessary during operation, proceed as follows:

- Switch the heater off at the control unit or
- pull the fuse out or
- disconnect the heater from the battery.

5 Electrical system

Heater wiring



Danger!

Danger high voltage

Before opening the heater, disconnect the plug-in connector with the vehicle.



Important!

Safety instructions!

The heater is to be connected up electrically according to the EMC directives. Improper tampering with the heater can affect the EMC. For this reason, comply with the following instructions:

- Ensure that the insulation of electrical cables is not damaged.
Avoid: Chafing, kinking, jamming or exposure to heat.
- Seal any connection chambers of waterproof connectors not in use with filler plugs to ensure they are dirt-proof and waterproof.
- Electrical connectors and earth connections must be free of corrosion and securely connected.
- Lubricate connections and ground connections outside the heater interior with contact grease.

Please note!

Comply with the following when wiring the heater and the control unit:

- The negative and positive poles of the heater's controls are to be directly connected to the vehicle's battery.
- Contact the heater manufacturer regarding connectors differing from the standard version.
- Electrical leads, switch and control gear must be positioned in the vehicle so that they can function perfectly under normal operating conditions without impairment (e.g. due to heat exposure, moisture, etc.).
- The following cable cross-sections are to be used between the battery and heater. This ensures that the max. permissible voltage drop in the cables does not exceed 0.5 V for 12 V or 1 V for 24 V rated voltage. Cable cross-sections for a cable length (plus cable + minus cable) of:
 - up to 5 m = cable cross-section 4 mm²
 - from 5 m to 8 m (plus cable + minus cable) = cable cross section 6 mm²
- If the positive cable is to be connected to the fuse box (e.g. terminal 30), the vehicle's cable from the battery to the fuse box must also be included in the calculation for the total cable length and re-dimensioned if necessary.
- Insulate unused cable ends.

Parts list for circuit diagram, heater and cable harness

-A10	Control box
-A	Connector housing to the cable harness
-B	Connector housing, burner motor
-C	Connector housing, overheating sensor
-D	Connector housing, fuel solenoid valve
-E	Connector housing, ignition spark generator
-F	Connector housing, heating element for fuel nozzle
-G	Connector housing, sensor, internal control temperature
-H	Relay block, heating cartridge
-I	Relay block, water pump
-A20	Ignition spark generator
-B1	Sensor, internal control temperature
-B2	Overheating sensor
-K6	Relay, water pump
-K10	Relay, heating cartridge
-M1	Burner motor
-R5	Heating element for fuel nozzle
-Y3	Fuel solenoid valve
-Z1	Ignition electrodes
a	Interface, heater / cable harness
-A30	Fuse holder, 3 pin
-F1	Fuse, heater
-F2	Fuse, control unit
-F4	Fuse, water pump
-K1	Fan relay
-M10	Water pump
-P1	Switch on control
-P3	Fault indicator lamp
-P6	Fuel indicator lamp
-S4	Switch, temperature drop
-S5	Switch, water pump
-XB1	Bush housing, supply / signals
-XB2	Bush housing, signals
-XB3	Bush housing to the heater
-XB5	Bush housing, water pump
-XB5/1	Bush housing, water pump
-XB7	Relay block, fan relay
-XS1	Connector housing, supply / signals
-XS2	Connector housing, signals
-XS5	Connector housing, water pump
-XS5/1	Connector housing, water pump
-XS8	Connector housing, water pump fault
a	Interface, heater / cable harness
c	to the control unit
f	Switch cable S+
m	Optionally terminal 15, terminal 30 or switch cable S+
w	Water pump external control
x	Insulate cable and tie back



5 Electrical system

Heater circuit diagram

- X:15 ○ _____
Ign (+)
- X:58 ○ _____
Light (+)
- X:30 ○ _____
Bat (+)
- X:31 ○ _____
Bat (-)

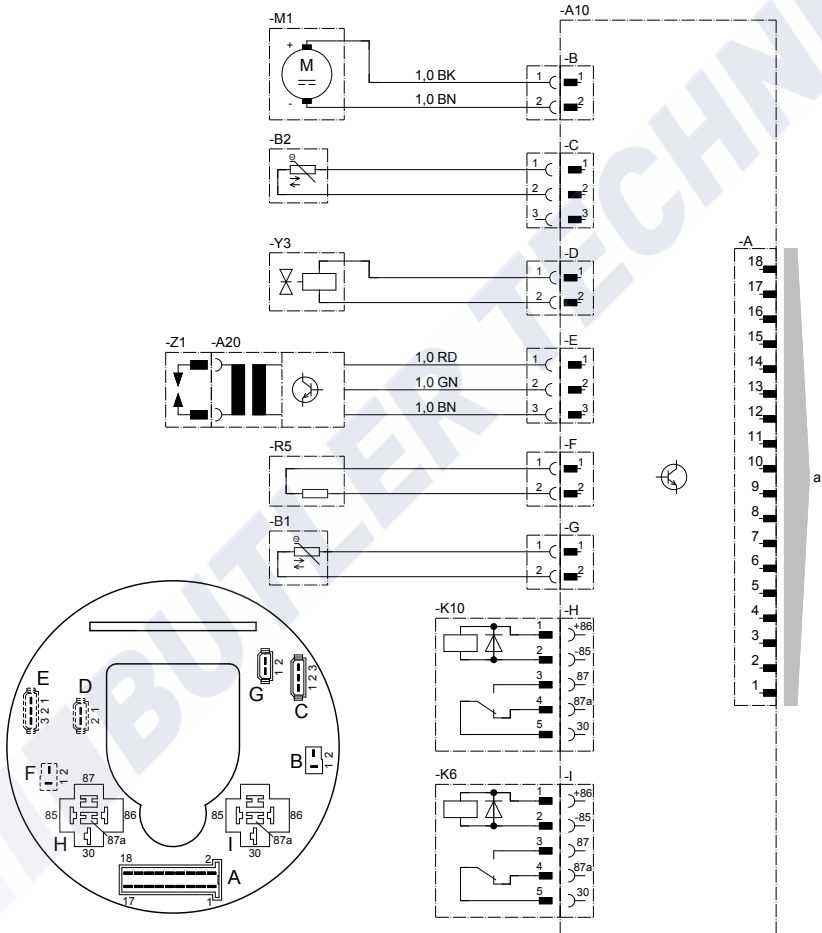

25.1818.00.9601

5 Electrical system

Cable harness circuit diagram

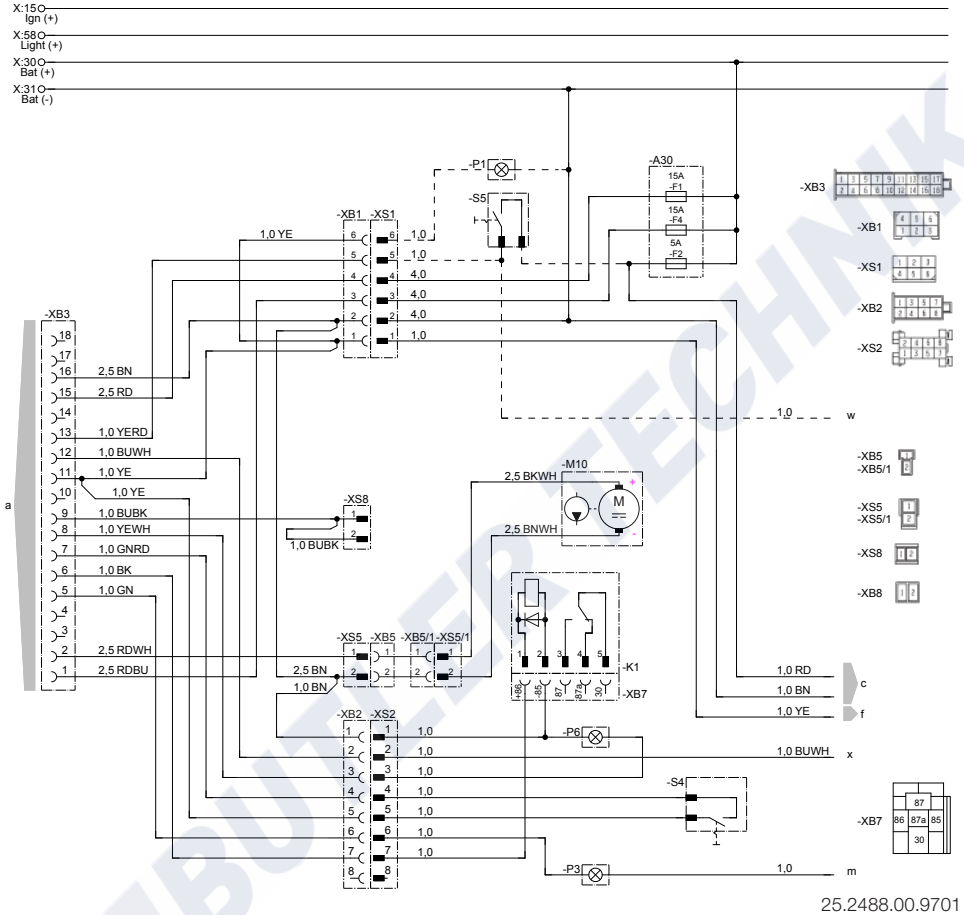

Connectors and bush housings are shown from the cable inlet side.

Cable colours

RD	red	GR	grey	BK	black
BU	blue	YE	yellow	GN	green
WH	white	VT	violet	BN	brown
OR	orange				



5 Electrical system

Circuit diagram – EasyStart Timer

X:15 ○
Ign (+)

X:58 ○
Light (+)

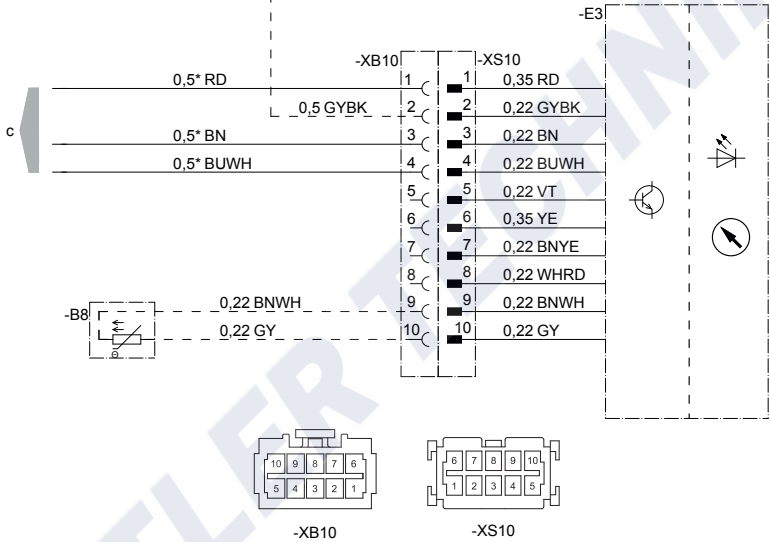

22.1000.34.9701

- B8 Room temperature sensor (optional)
- E3 EasyStart Timer
- c to the cable harness

Connectors and bush housings are shown from the cable inlet side.

i Note

Further circuit diagrams for the EasyStart Timer are printed in the Installation Instructions Plus, these are available to view and download from the Service Portal.

5 Electrical system

Circuit diagram – EasyStart Remote⁺

X:15 ♂
Ign (+)

X:58 ♂
Light (+)

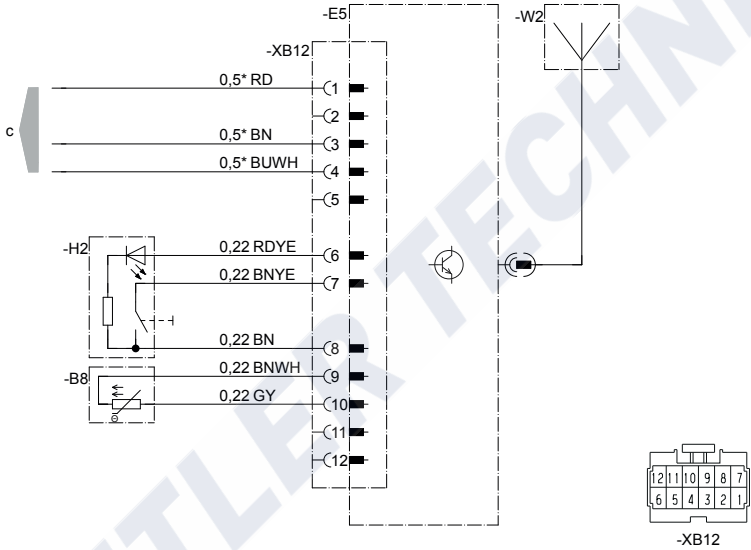

22 1000 34 9722

- B8 Room temperature sensor
- E5 Stationary unit, EasyStart Remote⁺
- H2 Button
- W2 Antenna
- c to the cable harness

Connectors and bush housings are shown from the cable inlet side.

i Note

Further circuit diagrams for the EasyStart Remote⁺ are printed in the Installation Instructions Plus, these are available to view and download from the Service Portal.



5 Electrical system

Circuit diagram – EasyStart Remote

X:15 Ign (+)

X:58 Light (+)

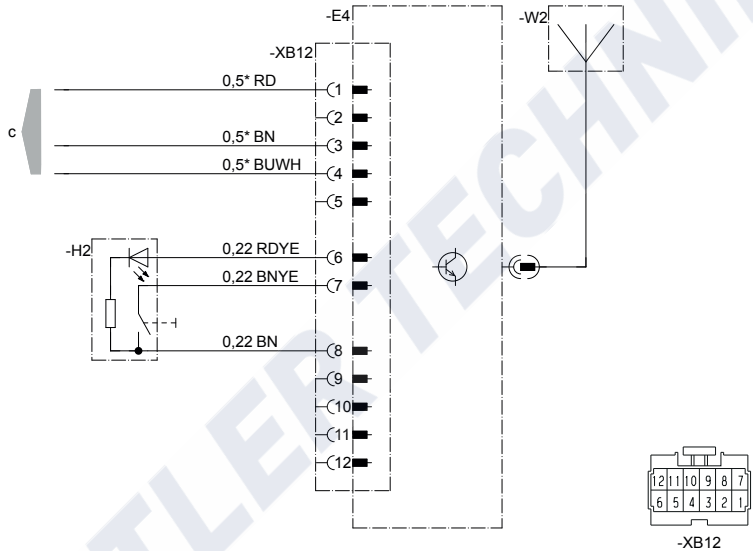

22.1000.34.9733

-E4 Stationary unit EasyStart Remote
 -H2 Button
 -W2 Antenna
 c to the cable harness

Connectors and bush housings are shown from the cable inlet side.

i Note

Further circuit diagrams for the EasyStart Remote are printed in the Installation Instructions Plus, these are available to view and download from the Service Portal.

5 Electrical system

Circuit diagram – EasyStart Select

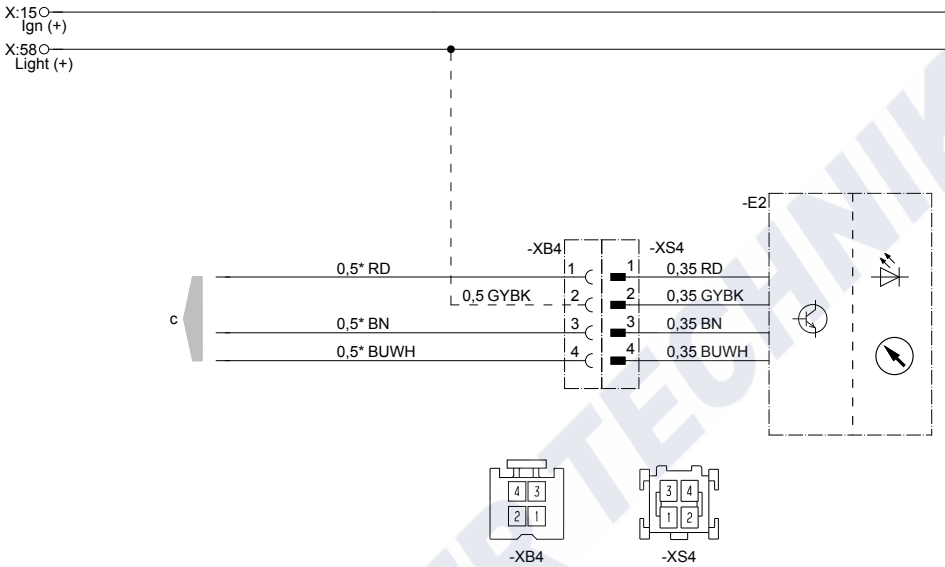

22.1000.34.9734

-E2 EasyStart Select
c to the cable harness

Connectors and bush housings are shown from the cable inlet side.

i Note

Further circuit diagrams for the EasyStart Select are printed in the Installation Instructions Plus, these are available to view and download from the Service Portal.



5 Electrical system

Circuit diagram – EasyStart Web

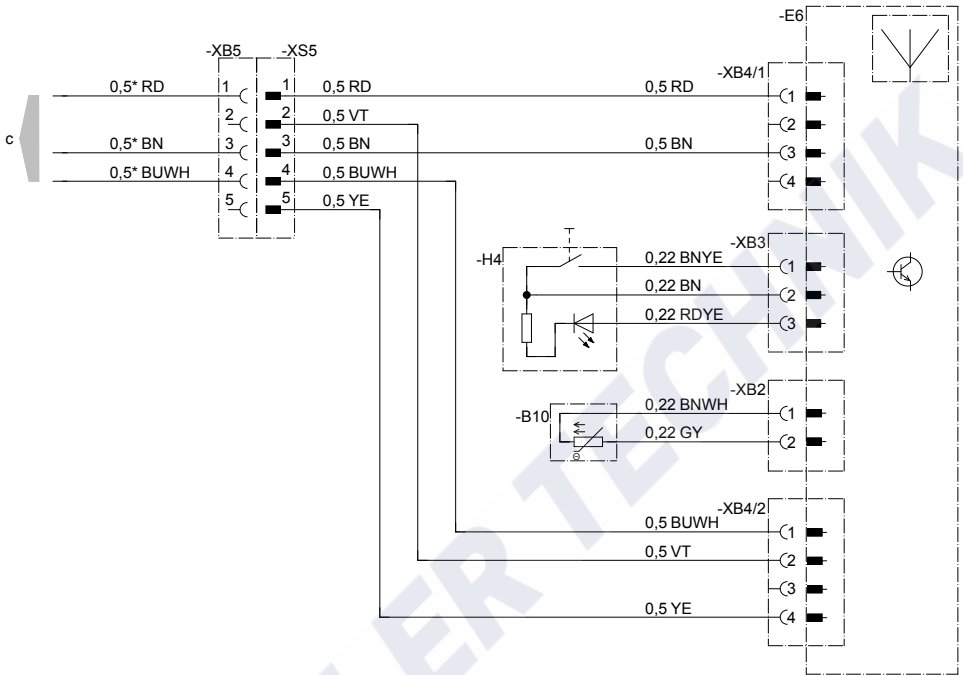

22.1000.34.9719

- B10 Room temperature sensor
- E6 EasyStart Web
- H4 Button
- c to the cable harness

Connectors and bush housings are shown from the cable inlet side.



Note

Further circuit diagrams for the EasyStart Web are printed in the Installation Instructions Plus, these are available to view and download from the Service Portal.

6 Troubleshooting / maintenance / service

If any faults occur, please check the following items

- If the heater does not start after being switched on:
 - Switch the heater off and on again.
- If the heater still does not start, check whether:
 - Fuel in the tank?
 - The fuses are ok?
 - The electrical cables, connections, terminals, are ok?
 - Anything is clogging the combustion air supply or exhaust system?
 - Fuel supply ok?

Troubleshooting

If, after checking these items, the heater is still faulty or another malfunction occurs in your heater, please contact:

- If factory-installed, your contract workshop / garage.
- If subsequently installed, the workshop / garage which installed the heater.

Please note!

Please note that guarantee claims can expire if the heater is modified by a third party or if non-original parts are installed.

Maintenance instructions

- Switch the heater on once a month for about 10 minutes, even outside the heating period.
- Before the heating period starts, a trial run should be carried out for the heater. If thick, persistent smoke develops, unusual burning noises or a clear fuel smell occurs or if electric / electronic parts overheat, the heater must be switched off and put out of service by removing the fuse.
In this case, the heater should not be started up again until it has been checked by qualified staff who have been trained on Eberspächer heaters.
- Check the openings of the combustion air supply and exhaust system after longer standstill periods, clean if necessary!

Please note!

Follow the maintenance schedule on page 43 to 45.

Initial commissioning

The following points are to be checked by the company installing the heater during initial commissioning.

- After installation of the heater, the coolant circuit and the whole fuel supply system must be vented carefully. Comply with the instructions issued by the vehicle manufacturer.
- Open the cooling water circuit before the trial run (set the temperature control to "WARM").
- During the heater trial run, all water and fuel connections must be checked for leaks and secure, tight fit.
- If faults occur while the heater is running, use a diagnostic unit to determine and correct the cause of the fault.

Changing components

The components listed below must be exchanged at the end of the given operating period:

- Heat exchanger after 5000 operating hours,
- Burner after 3000 operating hours,
- Nozzle after 600 operating hours or at least once per year.

Service

Technical Support

If you have any technical questions or problems with the heater, the control unit or the operating software, please contact the following service address:
support-UK@eberspaecher.com.



7 Environment

Certifications

The high quality of Eberspächer's products is the key to our success.

To guarantee this quality, we have organised all work processes in the company along the lines of quality management (QM). Even so, we still pursue a large number of activities for continuous improvement of product quality in order to keep pace with the similarly constantly growing requirements made by our customers.

All the steps necessary for quality assurance are stipulated in international standards. This quality is to be considered in a total sense.

It affects products, procedures and customer / supplier relationships.

Officially approved experts assess the system and the corresponding certification company awards a certificate.

Eberspächer Climate Control Systems GmbH & Co. KG has already qualified for the following standards:

Quality management in accordance with ISO TS 9001:2015 and IATF 16949:2016

Environmental management system in accordance with ISO 14001:2015

Disposal

Disposal of materials

Old devices, defective components and packaging materials can all be separated and sorted into pure-grade fractions, if necessary, so that all parts can be disposed of in an environment-friendly way or the materials recycled. Electric motors, control boxes and sensors (e.g. temperature sensors) are deemed to be "electronic scrap".

Dismantling the heater

The heater is dismantled according to the repair stages in the current troubleshooting / repair instructions.

Packaging

The heater's packaging can be kept in case it has to be sent back.

EU Declaration of Conformity

We herewith declare that the version of the heater placed on the market by us conforms to the applicable provisions of the following EU Directive.

EU Directive 2014/30/EU



The full Declaration of Conformity can be viewed and downloaded from the download centre under www.eberspaecher.com.

8 List

List of abbreviations

ADR

European agreement about the international transport of dangerous goods on the road.

ECE regulation

Internationally agreed, uniform technical specifications for vehicles, parts and equipment of motor vehicles.

EMC Directives

Electromagnetic compatibility.

JE-partner

Eberspächer partner.



9 Maintenance schedule

Data sheet

Details of the operator

Address

Date of measurement

Installed in rail vehicle

Heater details

Heater type

Year put into service

Nominal output in kW

Fuel
 Diesel Heating oil EL

Summary

The result complies with the requirements
 The result does not comply with the requirements (further action is necessary).

The check or adjustment has been performed:

Name: _____
Date: _____
Place: _____
Dept.: _____

Signature

/// BUTLER TECHNIK

/// BUTLER TECHNIK

www.eberspaecher.com

Eberspächer Climate Control Systems
GmbH & Co. KG
Eberspächerstr. 24
D - 73730 Esslingen
info@eberspaecher.com



Eberspächer®