



HYDRONIC D5W SC TROUBLESHOOTING MANUAL

Troubleshooting and error codes

Eberspächer

EN

J. Eberspächer
GmbH & Co. KG
Eberspächerstr. 24
D - 73730 Esslingen

Telefon (zentral)
(07 11) 9 39 - 00
Telefax
(07 11) 9 39 - 05 00

www.eberspaecher.com

The troubleshooting and repair instructions are valid for the following engine-independent water heaters:

Heaters for petrol

	Order No.
B 4 W SC – 12 volt	20 1821 01 00 00
B 5 W SC – 12 volt	20 1820 01 00 00

Heaters for diesel

	Order No.
D 4 W SC – 12 volt	25 2221 01 00 00
D 5 W SC – 12 volt	25 2219 01 00 00



4 Troubleshooting

When faults occur, first check ...

- Faulty wiring?
(short circuits, interruptions)
- Visual check for
 - corroded contacts
 - defect fuses
 - damaged electrical leads, links and connections
 - damaged exhaust and combustion air guidance
- Check battery voltage
Battery voltage < 10 volt: the undervoltage protection has triggered in *HYDRONIC* – 12 volt
- Check fuel supply
- When changing over to winter operations:
Is there still summer diesel in the pipes?
- **Check voltage supply U_{batt} (terminal 30)**
Disconnect the 8-pole connection S1 / B1 and measure the voltage present in connector B1 between chamber 1 (cable 2.5² red) and chamber 2 (cable 2.5² brown). For deviations in the battery voltage, check the fuses, supply lines, ground connection and plus point on battery for loss of voltage (corrosion / interruption).
- **Check switch-on signal (S+)**
Disconnect the 8-pole connector S1 / B1 and then press button  on the controls. Measure the voltage present in connector 1 between chamber 7 (cable 0.5² yellow) and chamber 2 (cable 2.5² brown). If there is no voltage, then check the power supply line (cable 0.5² yellow), the fuse 5A (item 2.7.1 in wiring diagram) and the controls.
- **Check controls (module timer / mini timer)**
Disconnect the connector from the controls and bridge cable 0.5² red and cable 0.5² yellow. If there is voltage in connector B1 between chamber 7 (cable 0.5² yellow) and chamber 2 (cable 2.5² brown), then replace the controls.

Controller lock

The controller is locked when the following faults occur:

- **Overheating**
If *HYDRONIC* overheats 10 times in succession, error code 015 appears à the controller is locked.
- **Too many start attempts**
If *HYDRONIC* performs 10 start attempts in vain, error code 050 appears à the controller is locked.

Cancel the controller lock

Cancelling the controller lock depends on the corresponding testing equipment and is described on pages 17 to 21.

Testing equipment

The following testing equipment can be used to query the fault memory in the controller and if necessary, to cancel the controller lock:

Testing equipment	Order number
• Diagnosis instrument (available until 12.2001) also necessary: adapter cable	22 1512 89 00 00 22 1000 30 71 00
• Diagnosis instrument (available as from 04.2002) also necessary: adapter cable	22 1529 89 00 00 22 1000 31 63 00
• Customer service program KD 2000 also necessary: adapter cable	22 1524 89 00 00 22 1000 31 63 00

If the diagnosis lead is connected up, the following controls can also be used:

• Module clock	22 1000 30 34 00
• Radio remote control TP5	22 1000 32 01 00



4 Troubleshooting

Testing equipment

The electronic controller of *HYDRONIC* can save up to 5 errors. The errors can be read and displayed from the controller using one of the following items of equipment. In addition, the controller lock can be cancelled.

- **Diagnosis instrument**

After connecting the diagnosis instrument, the function or error is shown numerically in the display. For connection and handling of the diagnosis instrument, see page 18 and 19. An adapter cable is necessary to connect up the diagnosis instrument. Error code table see page 23 to 28.

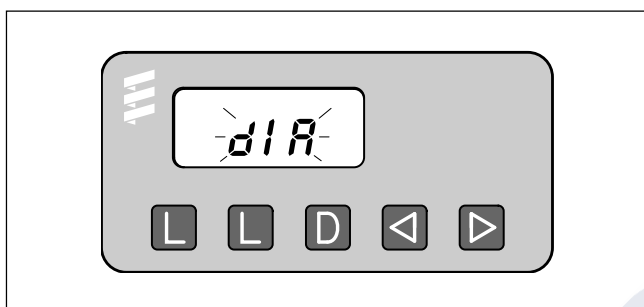

Order no.
Diagnosis instrument 22 1529 89 00 00
Adapter cable 22 1000 31 63 00

- **Module clock – installed in the vehicle**

The integrated module clock can be used to show the function or error numerically in the display. Handling the module clock see page 20. Error code table see page 23 to 28.

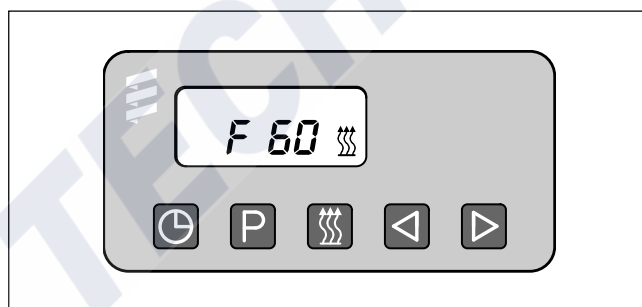

Order no.
Module clock 22 1000 30 34 00

- **Customer service program KD 2000**

After installation of the customer service program KD 2000 and connection of the ISO adapter, the function or error is shown numerically on the monitor. For connection and handling of the ISO adapter, see page 21.

An adapter cable is necessary to connect up the ISO adapter.

Error code table see page 23 to 28.

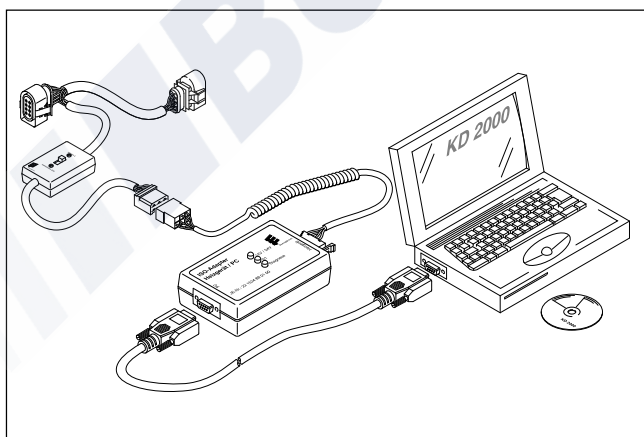

Order no.
ISO adapter 22 1524 89 00 00
Adapter cable 22 1000 31 63 00

- **Radio remote control TP5**

The radio remote control TP5 can be used to show the function or error numerically in the display.

Handling of the radio remote control TP5 see page 22. Error code table see page 23 to 28.



Order no.
Radio remote control TP5 22 1000 32 01 00

4 Troubleshooting

Fault diagnosis with the diagnosis instrument

Diagnosis instrument
Order no. 22 1529 89 00 00

An adapter cable is necessary to connect up the diagnosis instrument

Adapter cable
Order no. 22 1000 31 63 00

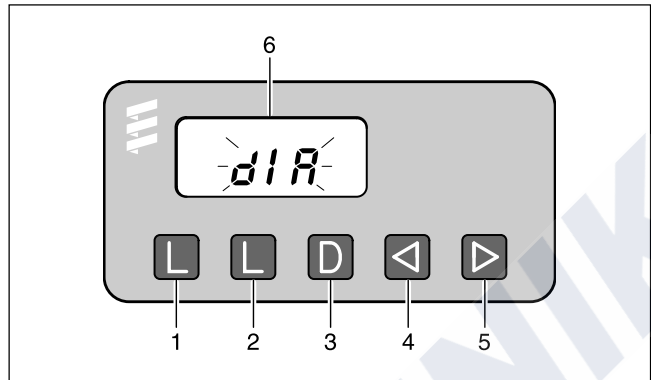

- ① Button **L** –delete fault memory
- ② Button **L** –delete fault memory
- ③ Button **D** –switch heater on / off request diagnosis
- ④ Button **◀** –backwards, fault F5 – F1, AF
- ⑤ Button **▶** –forwards, fault AF, F1 – F5
- ⑥ Display

The electronic controller of *HYDRONIC* can save up to 5 faults, which can be read and displayed with the diagnosis instrument.

The current fault is shown as “AF” and a 2-digit number and always written in memory place F1. Previous faults are transferred to memory places F2 to F5, and the contents of memory place F5 are overwritten.

Connecting up the diagnosis instrument

- Disconnect the 8-pole connector from the *HYDRONIC* cable harness and connect the adapter cable.
- Then connect the diagnosis instrument to the adapter cable.

The display shows:

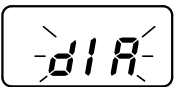

Querying the fault memory

- Press the button **D** on the diagnosis unit to switch on *HYDRONIC*.

The display shows:



- After 8 secs, the display shows:



no error

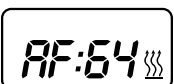

current fault (e.g. error code 64)

Error code, fault description, cause and remedies are described on pages 23 to 28.



Fault diagnosis not possible

Possible causes:

- adapter cable not connected properly
- controller defect or not capable of diagnosis (not a universal controller).

Display of fault memory F1 – F5 or F5 – F1

- Press the buttons **◀** or **▶** once or several times to show the individual fault memories in decreasing or increasing order. The display shows:

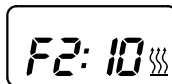

e.g. fault memory 2 / error code 10

Only those fault memories occupied by a fault are shown.

Delete fault memory

- Eliminate cause of fault.
- Press both buttons **L** at the same time until the display shows:

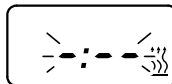

- Once the fault memories are deleted, the last current fault is shown. The current fault is not reset to 00 until the next restart of *HYDRONIC*, insofar as no other current fault has occurred. The display shows:

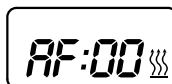

HYDRONIC no faults

4 Troubleshooting

Controller lock

- Overheating:
If *HYDRONIC* overheats 10 times in succession, fault 012, AF 015 appears in the display, i.e. the controller is locked.
- Too many start attempts:
If *HYDRONIC* performs 10 start attempts in vain, fault 052, AF 050 appears in the display, i.e. the controller is locked.

Please note

Not only a defect component but also a defect current path results in a display.

Cancelling the controller lock

- Delete the fault memory as described and switch off *HYDRONIC* with button .
- The controller lock is cancelled and the diagnosis finished.
The display shows:

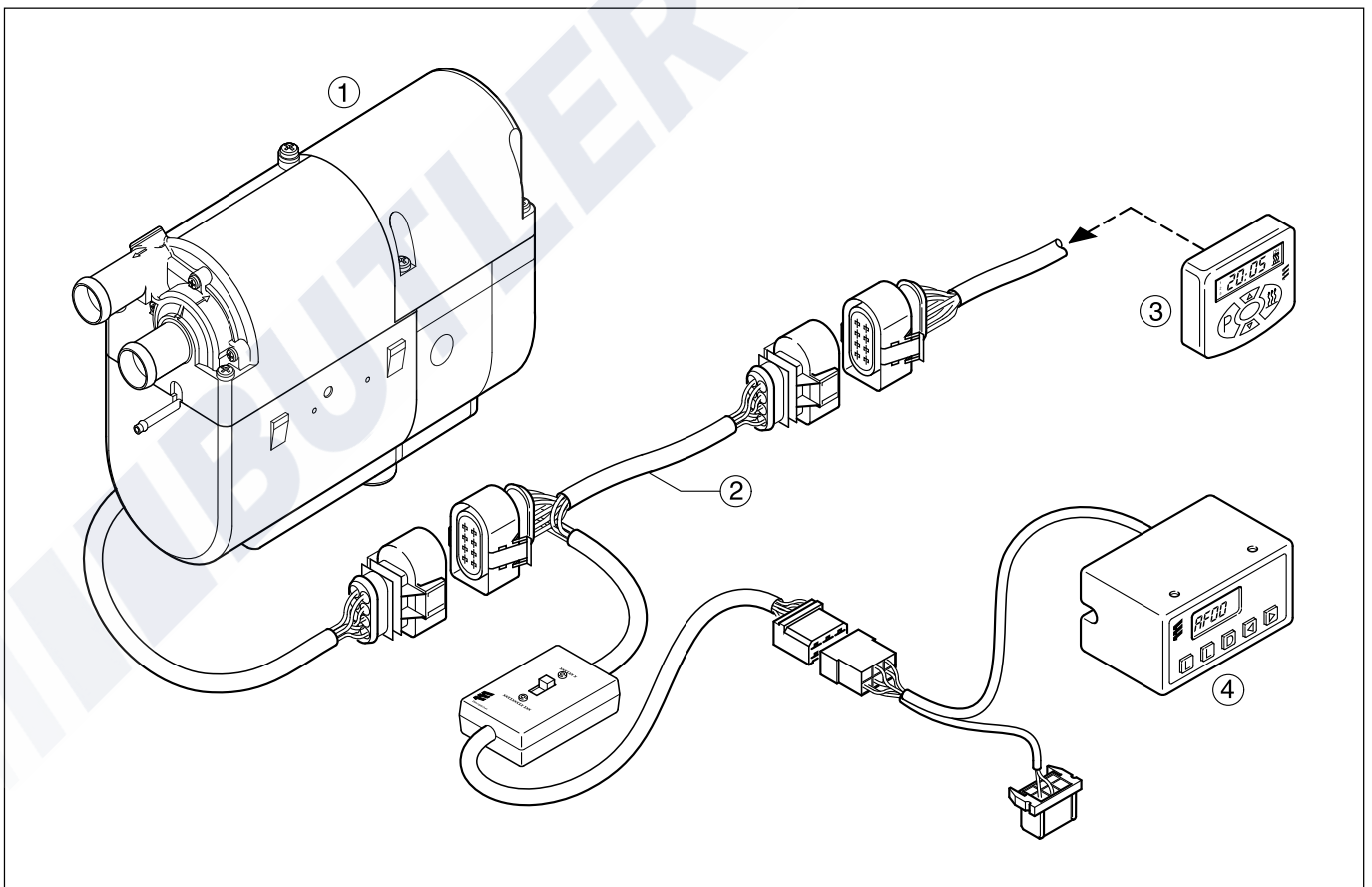
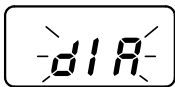

- ① *HYDRONIC*
- ② Adapter cable
- ③ Mini timer
- ④ Diagnosis instrument

4 Troubleshooting

Fault diagnosis with the module clock

Module clock
Order no. 22 1000 30 34 00

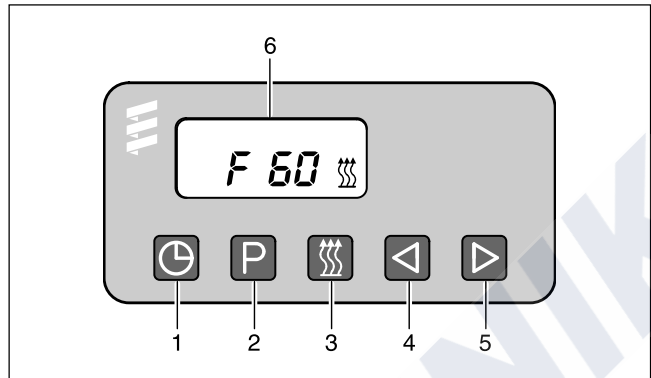

- ① Button – time
- ② Button – preselection
- ③ Button – heating
- ④ Button – backwards
- ⑤ Button – forwards
- ⑥ Display showing the faults

The electronic controller can save up to 5 faults, which can be read and displayed with the module clock. The current fault is shown as “AF” and is always written in memory place F1. Previous faults are transferred to memory places F2 to F5, and the contents of memory place F5 are overwritten.

Query fault memory F1 to F5

Condition:
HYDRONIC is switched off.

- Press button --> *HYDRONIC* is switched on.
- Press button and hold pressed, then press button within 2 seconds.
The display shows:
AF = current fault
3 digit number = error code
 flashes.
- Press button once or several times, fault memories F1 to F5 are shown.

Please note

Error code, fault description, cause / remedies are described on pages 23 to 28.

Cancel the controller lock and at the same time delete the fault memory

Condition:
There is an electrical connection from terminal 15 (ignition) to the module clock, 12-pole connector, chamber 10.

- Press button
The display shows:
current fault F15 or F50.
- Press button , hold pressed and press button within 2 seconds.

The module clock is now in the program “query fault memory”.

- Switch off the ignition (terminal 15).
- Press button and button at the same time, also switch the ignition on (terminal 15) and wait until the following is shown in the display.

After ignition “ON”, the display shows:

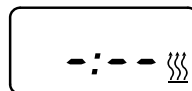

Display flashes
Heating symbol does not flash

- Switch *HYDRONIC* off and on --> the controller is unlocked, *HYDRONIC* starts again.

After switching off and on and after querying the fault memory again, the display shows:



Display flashes
Heating symbol does not flash



4 Troubleshooting

Fault diagnosis with customer service program KD 2000

Customer service program KD 2000
Order no. 22 1524 89 00 00

An adapter cable is required to connect the ISO adapter.
Order no. 22 1000 31 63 00

The electronic controller can save up to 5 faults.
The faults can be read and displayed with the ISO adapter and the KD 2000 software.

Connect the ISO adapter

- Disconnect the *HYDRONIC* cable harness.
- Connect the adapter cable into the cable harness as shown in the drawing.
- Connect the adapter cable to the ISO adapter.
- Connect the SUB-D connection cable with the PC and the ISO adapter.

Please note

It is vitally important to comply with the order of installation.

Install KD 2000 software on the computer

- Place the CD-ROM in the CD drive
- Do a double click to run the file "setup.exe" and follow the instructions of the SETUP program.

Query fault memory F1 – F5 / delete fault memory / cancel controller lock

- Run KD 2000 software on the computer:
 - On the desktop, do a double click on the "KD 2000" icon
 - Select the heater type
 - Press "GO".
- Delete fault memory respectively cancel controller lock:
 - Press button "delete fault memory"
 - > the saved faults F1 to F5 are deleted and the controller is unlocked.

Finish diagnosis

- Press button "STOP" --> this finishes the fault memory query.

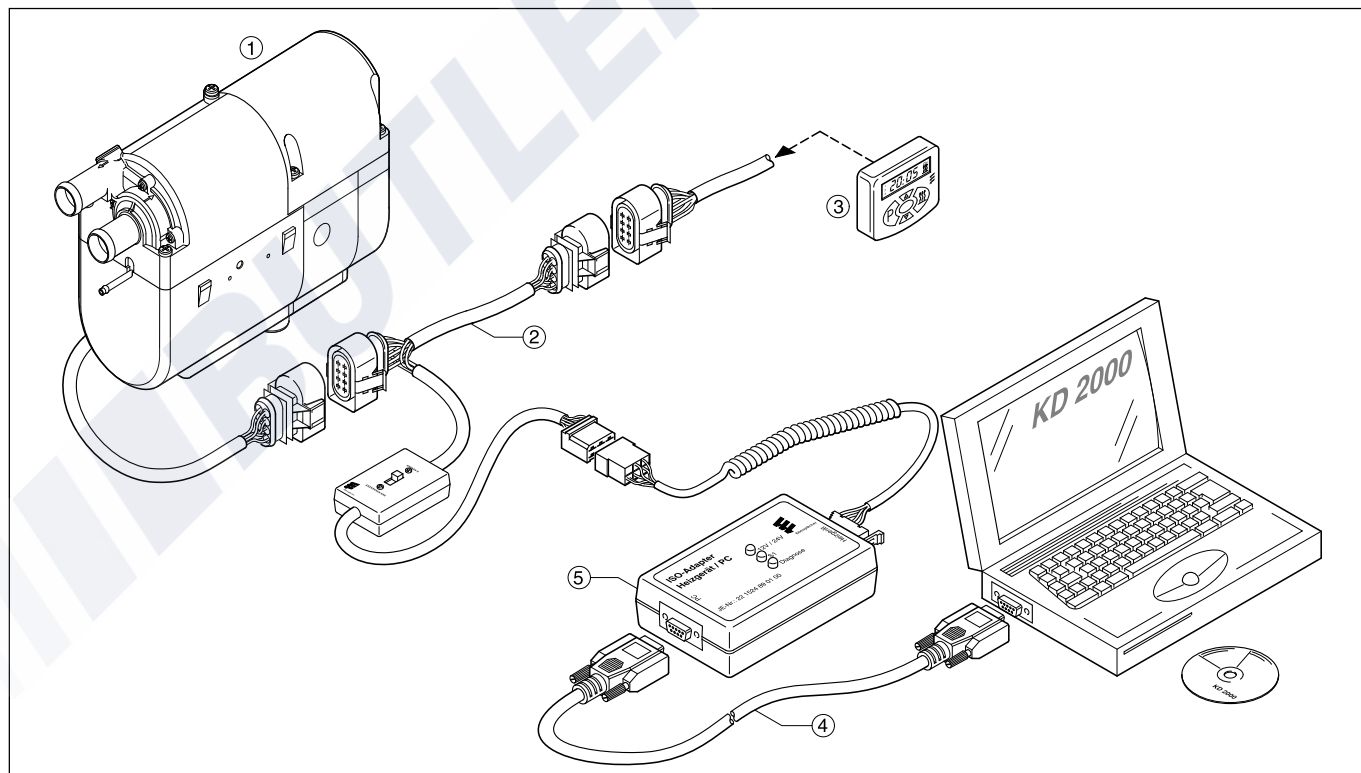





- ① *HYDRONIC*
- ② Adapter cable
- ③ Mini timer
- ④ SUB-D connection cable
- ⑤ ISO adapter

4 Troubleshooting

Fault diagnosis with radio remote control TP5

Radio remote control TP5
Order no. 22 1000 32 01 00

-  Button to activate / deactivate the remote control
-  Button to move time setting forwards
-  Button to move time setting backwards
-  Button to activate adjustment possibilities
-  Button for ON / OFF for heating / venting; activate / deactivate preselection time



If errors occur in the heater during operation, once the remote control has been activated these are shown with "Err".

Please note

Prerequisite for performing the diagnosis is that the diagnosis lead (blue / white) is connected to the stationary part and to the heater cable harness, complying with the circuit diagram for the radio remote control TP5 and the heater.

Note:
The "diagnosis" menu is blocked when the diagnosis lead (blue / white) is not connected.



Once the diagnosis lead (blue / white) has been connected and the first protocols have arrived at the stationary set, the diagnosis can be performed with the radio remote control TP5. The current fault "F0" is shown. The saved faults "F1" to "F5" can be queried. The error is to be eliminated according to the troubleshooting and repair instructions of the heater.

Example:

- „F0 --“ = error-free operation
- „F011“ = current fault 11
- „F110“ = fault 10 saved in fault memory 1 ("F1").

Error code, fault description, cause and remedies are described on pages 23 to 28.



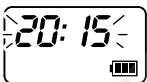

Query / delete fault memory

Press button  to activate the remote control.
Switch the heater on with button .
Press button  twice to go to the time adjusting menu – the time flashes in the display.



Press button  for approx. 2 seconds in the display, until the display shows the following:





- Press button .
- Press button .
- Press button  2 x.
- Press button .

Heater with error:

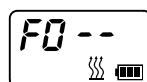

Heater without error:





Use buttons  and  to go to fault memories 1 to 5.

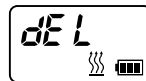

Delete fault memory / cancel controller lock

Press button  to delete the fault memory.



Press button  for approx. 2 secs. to confirm until  lights up in the display: fault memory is deleted.



Please note



If the fault memory is deleted at a later point in time, the whole procedure has to be repeated.



4 Troubleshooting

Error code Display	Fault description	Explanations • Remedies
010	Overvoltage – shutdown	<p>Overvoltage at controller min. 20 seconds without interruption --> <i>HYDRONIC</i> does not function.</p> <ul style="list-style-type: none"> • Disconnect connection B1/S1, start vehicle engine, measure voltage in connector B1 between chamber 1 (cable 2.5² red) and chamber 2 (cable 2.5² brown). If the voltage > 15 volt, then check the dynamo regulator or battery.
011	Undervoltage – shutdown	<p>Undervoltage at controller min. 20 seconds without interruption --> <i>HYDRONIC</i> does not function.</p> <ul style="list-style-type: none"> • Disconnect connection B1/S1, vehicle engine is off, measure voltage in connector B1 between chamber 1 (cable 2.5² red) and chamber 2 (cable 2.5² brown). If voltage < 10 volt, then check fuses, supply lines, ground connections and plus points on battery for loss of voltage (corrosion).
012	Overheating (software – threshold value)	<p>Temperature at overheating sensor > 125°C.</p> <ul style="list-style-type: none"> • Check water circuit; <ul style="list-style-type: none"> – Check all hoses for any leaks – Is there a throttle in the water circuit? – Has the direction of flow been observed when installing thermostat and non-return valve? – Is the water circuit properly vented? – Check functions of water pump • Check temperature sensor and overheating sensor, replace if necessary – control values see page 38.
014	Possible overheating detected (differential evaluation)	<p>Difference in temperature values of overheating sensor and temperature sensor > 25 K. Prerequisite for this error code is that <i>HYDRONIC</i> is operating and the water temperature at the overheating sensor has reached min. 80°C.</p> <ul style="list-style-type: none"> • Check water circuit: <ul style="list-style-type: none"> – Check all hoses for any leaks – Is there a throttle in the water circuit? – Has the direction of flow been observed when installing thermostat and non-return valve? – Is the water circuit properly vented? – Check functions of water pump • Check temperature sensor and overheating sensor, replace if necessary – control values see page 38.
015	Operation lock – heater has overheated more than 10 times	<p>Controller is locked</p> <ul style="list-style-type: none"> • Unlock controller by deleting fault memory (see page 18 to 21). • Check water circuit <ul style="list-style-type: none"> – Check all hoses for any leaks – Is there a throttle in the water circuit? – Has the direction of flow been observed when installing thermostat and non-return valve? – Is the water circuit properly vented? – Check functions of water pump.

4 Troubleshooting

Error code Display	Fault description	Explanations • Remedies
017	Overheating detected – EMERGENCY OFF (hardware limit value)	<p>Temperature at overheating sensor > 130°C.</p> <ul style="list-style-type: none"> • Check water circuit: <ul style="list-style-type: none"> – Check all hoses for any leaks. – Is there a throttle in the water circuit? – Has the direction of flow been observed when installing thermostat and non-return valve? – Is the water circuit properly vented? – Check functions of water pump. • Check temperature sensor and overheating sensor, replace if necessary – control values see page 38.
020	Glow plug – interruption	<ul style="list-style-type: none"> • Perform function test of glow plug in installed condition. To do so, unclip cable 1.5² white from chamber 9 of the 14-pole connector and cable 1.5² brown from chamber 12. Apply voltage of 8 V ± 0.1 V to the glow plug and measure current after 25 sec. The glow plug is OK with the following values; if the values differ, replace the glow plug. Glow plug 8 volt – current = 8.5 A ^{+1A}_{-1.5A} • If glow plus is OK, check glow plug lead for any signs of damage, check for current passage.
021	<p>Glow plug output: short circuit, overload or accidental ground</p>  <p>Caution In <i>HYDRONIC</i> 12 volt, perform the function test with max. 8 volt. Glow plug destroyed if voltage values exceeded. → Ensure mains adapter is short-circuit proof.</p>	
030	<p>Speed of combustion fan motor outside tolerance range.</p>  <p>Caution In <i>HYDRONIC</i> 12 volt, perform the function test with max. 8.2 volt + 0.2 volt. Check that plus an minus leads are connected correctly. → Ensure mains adapter is short-circuit proof.</p>	<p>Fan impeller of combustion air fan motor blocked (frozen, dirty, stiff, lead chafes at end of shaft ...).</p> <ul style="list-style-type: none"> • Remove blockage. • Measure speed of combustion air fan motor with max. 8.2 volt + 0.2 volt. To do so, unclip cable 0.75² brown from chamber 14 of 14-pole connector and cable 0.75² black from chamber 13. Affix a marking to the shaft end of the combustion air fan motor and measure the speed with a contact-free speed counter (see page 38). If the measured speed < 10 000 rpm, then replace the combustion air fan. If the measured speed > 10 000 rpm, then replace the controller.
031	<p>Combustion air motor – interruption</p>  <p>Caution In <i>HYDRONIC</i> 12 volt, perform the function test with max. 8.2 volt + 0.2 volt. Check that plus an minus leads are connected correctly. → Ensure mains adapter is short-circuit proof.</p>	<ul style="list-style-type: none"> • Check that the cable harness of the combustion air fan motor is properly routed and check for any signs of damage. • Measure speed of combustion air fan motor with max. 8.2 volt + 0.2 volt. To do so, unclip cable 0.75² brown from chamber 14 of 14-pole connector and cable 0.75² black from chamber 13. Affix a marking to the shaft end of the combustion air fan motor and measure the speed with a contact-free speed counter (see page 38). If the measured speed < 10 000 rpm, then replace the combustion air fan. If the measured speed > 10 000 rpm, then replace the controller.



4 Troubleshooting

Error code Display	Fault description	Explanations • Remedies
032	<p>Combustion air motor – short circuit, overload or accidental ground</p> <p> Caution In <i>HYDRONIC</i> 12 volt, perform the function test with max. 8.2 volt + 0.2 volt. Check that plus an minus leads are connected correctly. → Ensure mains adapter is short-circuit proof.</p>	<p>Fan impeller of combustion air fan motor blocked (frozen, dirty, stiff, lead chafes at end of shaft ...).</p> <ul style="list-style-type: none"> • Remove blockage. • Before checking the functions of the combustion air fan motor, perform a resistance measurement between housing and lead. If the measured resistance < 2 kΩ, then there is accidental ground. Replace the combustion air fan. If the measured value is > 2 kΩ, then measure the speed of the combustion air fan motor. • Measure speed of combustion air fan motor with max. 8.2 volt + 0.2 volt. To do so, unclip cable 0.75² brown from# chamber 14 of 14-pole connector and cable 0.75² black# from chamber 13. Affix a marking to the shaft end of the combustion air fan# motor and measure the speed with a contact-free speed# counter (see page 36). If the measured speed < 10 000 rpm, then replace the combustion air fan. If the measured speed > 10 000 rpm, then replace the controller.
038	<p>Relay trigger of vehicle fan – interruption</p> <p>Please note This fault code is not displayed by all types of heaters.</p>	<ul style="list-style-type: none"> • Check electric lead to relay, rectify interruption, replace relay if necessary.
039	<p>Relay trigger of vehicle fan – short circuit, overload or accidental ground</p>	<ul style="list-style-type: none"> • Pull relay off; if error code 038 is then shown, the relay is defect – replace relay.
041	<p>Water pump – interruption</p>	<ul style="list-style-type: none"> • Check lead to water pump for current passage. To do so, unclip cable 0.5² brown from chamber 10 of 14-pole connector and cable 0.5² from cable 11. Rectify interruption, replace water pump if necessary.
042	<p>Water pump – short circuit, overload or accidental ground</p>	<ul style="list-style-type: none"> • Disconnect connection in water pump cable harness. If error code 041 is then shown, the water pump is defect – replace water pump.
047	<p>Dosing pump – short circuit, overload or accidental ground</p>	<ul style="list-style-type: none"> • Disconnect connection in dosing pump cable harness. If error code 048 is then shown, the dosing pump is defect – replace dosing pump.
048	<p>Dosing pump – interruption</p>	<ul style="list-style-type: none"> • Check dosing pump cable harness for current passage. Rectify interruption, replace dosing pump if necessary.
050	<p>Operation lock because of too many failed starting attempts (10 starting attempts, also start repetition for every starting attempt)</p>	<p>Too many starting attempts, controller locked.</p> <ul style="list-style-type: none"> • Unlock controller by deleting fault memory (see page 18 to 21). • Check fuel quantity and fuel supply, see page 41.

4 Troubleshooting

Error code Display	Fault description	Explanations • Remedies
051	Time exceeded – blowing cold	At start, flame sensor reports temperature > 70°C for longer than 240°C. <ul style="list-style-type: none"> • Check exhaust and combustion air guidance. • Check flame sensor – control values see page 34.
052	Safety time exceeded	<ul style="list-style-type: none"> • Check exhaust and combustion air guidance. • Check fuel quantity and fuel supply, see page 41. • Clean or replace filter in dosing pump connection.
053 056	Flame aborted from control stage “large” Flame aborted from control stage “small”	<p>Warning</p> <p>After flame aborted from control stage “large” or “small” and after starting attempt within allowed number, <i>HYDRONIC</i> proceeds with a new start, where applicable with subsequent start repeat.</p> <p>If the new start or start repeat is successful, the error code is deleted.</p> <p>Error (because no more starting attempts allowed)</p> <ul style="list-style-type: none"> • Check exhaust and combustion air guidance. • Check fuel quantity and fuel supply, see page 41. • Check flame sensor, see error code 064 and 065.
060	Temperature sensor – interruption <div data-bbox="225 1122 411 1158" style="border: 1px solid black; padding: 2px; width: fit-content;"> Please note </div> The test with a bridge in the 14-pole connector can only be performed if <i>HYDRONIC</i> is still installed in the vehicle or if a test facility is available.	<ul style="list-style-type: none"> • Remove controller and check connection lead of temperature sensor for any signs of damage. If the lead is OK, then short the temperature sensor: route the cable in the 14-pole connector from chamber 3 to chamber 4. Switch <i>HYDRONIC</i> on: <ul style="list-style-type: none"> – If error code 061 appears, then remove and check temperature sensor, see page 38. – If error code 060 still appears, then check and if necessary replace controller.
061	Temperature sensor – short-circuit, overload or accidental ground <div data-bbox="225 1469 411 1505" style="border: 1px solid black; padding: 2px; width: fit-content;"> Please note </div> The test with a bridge in the 14-pole connector can only be performed if <i>HYDRONIC</i> is still installed in the vehicle or if a test facility is available.	<ul style="list-style-type: none"> • Remove controller and check connection lead of temperature sensor for any signs of damage. If the lead is OK, then remove the 14-pole connector from controller, unclip cable 0.5² blue from chamber 3 and cable 0.5² blue from chamber 4. Connect 14-pole connector to controller and switch <i>HYDRONIC</i> on. <ul style="list-style-type: none"> – If error code 061 appears, then remove and check temperature sensor, see page 38. – If error code 061 appears, then check and if necessary replace controller.



4 Troubleshooting

Error code Display	Fault description	Explanations • Remedies
064	Flame sensor – interruption <div style="border: 1px solid black; padding: 2px; width: fit-content; margin: 5px 0;">Please note</div> The test with a bridge in the 14-pole connector can only be performed if <i>HYDRONIC</i> is still installed in the vehicle or if a test facility is available.	<ul style="list-style-type: none"> • Remove controller and check connection lead of flame sensor for any signs of damage. If the lead is OK, then short the flame sensor: route the cable in the 14-pole connector from chamber 1 to chamber 2. Switch <i>HYDRONIC</i> on: <ul style="list-style-type: none"> – If error code 065 appears, then remove and check flame sensor, see page 34. – If error code 064 still appears, then check and if necessary replace controller.
065	Flame sensor – short-circuit, overload or accidental ground <div style="border: 1px solid black; padding: 2px; width: fit-content; margin: 5px 0;">Please note</div> The test with a bridge in the 14-pole connector can only be performed if <i>HYDRONIC</i> is still installed in the vehicle or if a test facility is available.	<ul style="list-style-type: none"> • Remove controller and check connection lead of flame sensor for any signs of damage. If the lead is OK, then remove the 14-pole connector from controller, unclip cable 0.5² blue from chamber 1 and cable 0.5² brown from chamber 2. Connect 14-pole connector to controller and switch <i>HYDRONIC</i> on. <ul style="list-style-type: none"> – If error code 064 appears, then remove and check flame sensor, see page 34. – If error code 065 appears, then check and if necessary replace controller.
071	Overheating sensor – interruption <div style="border: 1px solid black; padding: 2px; width: fit-content; margin: 5px 0;">Please note</div> The test with a bridge in the 14-pole connector can only be performed if <i>HYDRONIC</i> is still installed in the vehicle or if a test facility is available.	<ul style="list-style-type: none"> • Remove controller and check connection lead of overheating sensor for any signs of damage. If the lead is OK, then short the overheating sensor: route the cable in the 14-pole connector from chamber 5 to chamber 6. Switch <i>HYDRONIC</i> on: <ul style="list-style-type: none"> – If error code 072 appears, then remove and check overheating sensor, see page 38. – If error code 071 still appears, then check and if necessary replace controller.
072	Overheating sensor – short-circuit, overload or accidental ground <div style="border: 1px solid black; padding: 2px; width: fit-content; margin: 5px 0;">Please note</div> The test with a bridge in the 14-pole connector can only be performed if <i>HYDRONIC</i> is still installed in the vehicle or if a test facility is available.	<ul style="list-style-type: none"> • Remove controller and check connection lead of overheating sensor for any signs of damage. If the lead is OK, then remove the 14-pole connector from controller, unclip cable 0.5² red from chamber 5 and cable 0.5² red from chamber 6. Connect 14-pole connector to controller and switch <i>HYDRONIC</i> on. <ul style="list-style-type: none"> – If error code 071 appears, then remove and check overheating sensor, see page 38. – If error code 072 appears, then check and if necessary replace controller.
090 092–103	Controller defect	Replace controller.
091	External interference voltage	Error in controller from interference voltage from vehicle network, possible causes: poor batteries, poor battery chargers, other interference sources; eliminate interference voltages.

4 Troubleshooting

Faults not shown by the diagnosis system

Fault description	Explanations • Remedies
<i>HYDRONIC</i> won't start	<p>After switching <i>HYDRONIC</i> on, the water pump and vehicle fan start immediately.</p> <ul style="list-style-type: none">• Remove and check temperature sensor, see page 38. <p>After switching <i>HYDRONIC</i> on, the vehicle fan starts, function "pre-venting" is activated.</p> <ul style="list-style-type: none">• Changeover venting to heating at "heating / venting" changeover switch.