

HYDRONIC

D5WSC INSTALLATION MANUAL



Heater

Hydronic B 4 W SC – 12 V
as complete package

Order no.

20 1861 05 00 00

Hydronic B 4 W SC – 12 V

20 1824 05 00 00

Hydronic B 5 W SC – 12 V
as complete package

20 1863 05 00 00

Hydronic B 5 W SC – 12 V

20 1820 05 00 00

Heater

Hydronic D 4 W SC – 12 V
as complete package

Order no.

25 2385 05 00 00

Hydronic D 4 W SC – 12 V

25 2257 05 00 00

Hydronic D 5 W SC – 12 V
as complete package

25 2390 05 00 00

Hydronic D 5 W SC – 12 V

25 2219 05 00 00

**Water heater for diesel and petrol
operating independently of the engine.**





3 Installation

Installation location

The installation location for the heater is the engine compartment. The heater must be mounted below the min. cooling water level (compensation tank, cooler, vehicle heat exchanger) for automatic venting of the heat exchanger of the heater and the water pump.

Please note!

- The regulations and safety instructions to be observed for this chapter are stated on page 4 – 7.
- The installation suggestions made in the installation instructions are examples. Other installation locations are possible if they correspond to the installation requirements stated in these installation instructions.
- Other installation information (e.g. for boats and ships) is available from the manufacturer on request.
- Observe the tolerable installation position together with the operating and storage temperatures.

Installation example for heater in a delivery van and a car

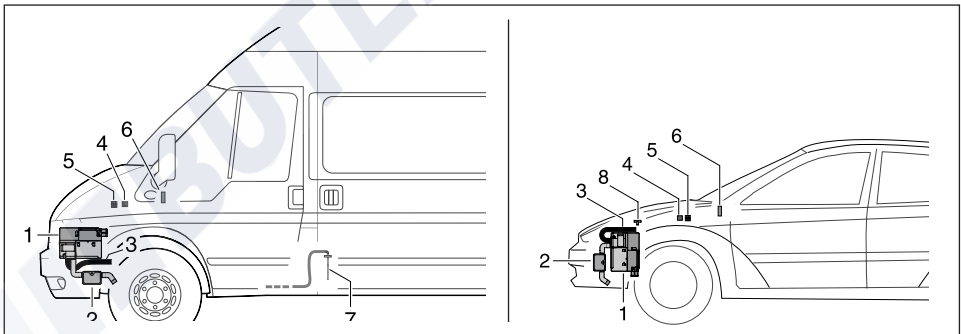

- 1 Heater
- 2 Exhaust pipe with exhaust silencer
- 3 Combustion air intake silencer
- 4 Fan relay

- 5 Fuse bracket
- 6 Control unit
- 7 Rising pipe
- 8 T-piece for fuel

3 Installation

Possible installation positions

The heater should preferably be installed in the normal position, horizontal with the exhaust connection down to the bottom.

Depending on the installation conditions, the heater can also be mounted in the permitted swivel range, see diagram.

When the heater is operating, the shown normal or maximum installation positions can be varied briefly by up to +15° in all directions. Such deviations caused by the inclined position of the vehicle do not impair the heater functions in any way.

Normal position with permitted swivel range

- Swivel range from the normal position swivelled down to max. 90°: the water connections point downwards.
- Swivel range from the normal position to max. 90° swivelled around the longitudinal axis: the water connections are horizontal.

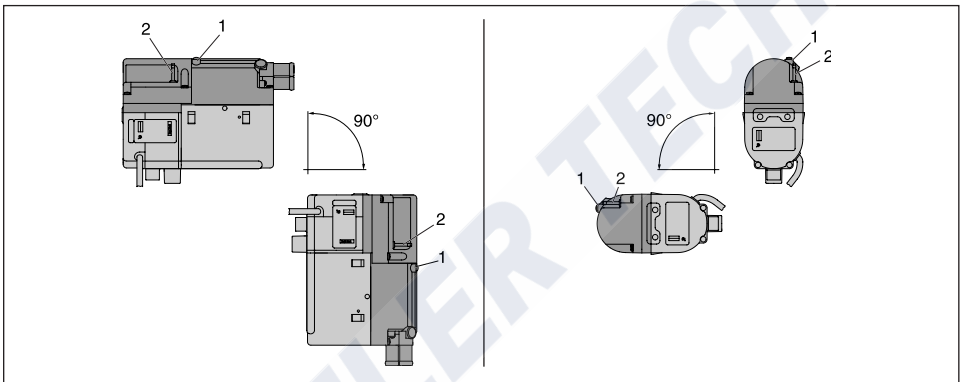

- 1 Vent screw: must always be at the top
- 2 Fuel connection

Mounting and fastening

Position the heater in the holding clips of the heater bracket and fasten with fastening screw, M6 x 97 (tightening torque 6^{+0.5}Nm). Mount the heater bracket in a suitable position in the engine compartment, possibly using anti-vibration pads if necessary.

Please note!

Depending on the installation space available, the heater can be moved sideways in the bracket and screwed in one of the two fastening threads.

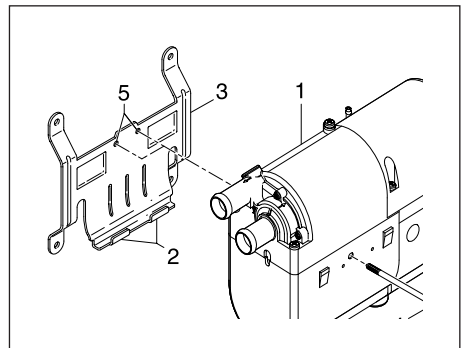

- 1 Heater
- 2 Bracket clips
- 3 Bracket holder
- 4 Fastening screw
- 5 Fastening thread



3 Installation

Nameplate

The nameplate is fastened to the front of the heater.
The second nameplate (duplicate) is included in the scope of supply of the heater.
If required, the duplicate nameplate can be adhered in a clearly visible position on the heater or near to the heater.

Please note!

The regulations and safety instructions to be observed for this chapter are stated on page 5.

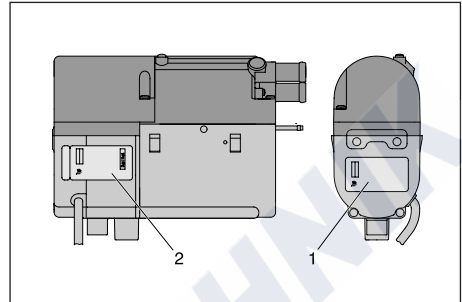

- 1 Original nameplate
- 2 2nd nameplate (duplicate)

3 Installation

Connection to the cooling water circuit

The heater is connected to the cooling water circuit in the water feed pipe from the vehicle engine to the heat exchanger. There are four possible alternative installations here.

The alternatives are described on pages 19 – 21.



Danger! **Risk of injuries and burns!**

It is possible for the coolant and components of the coolant circuit to get very hot.

- Parts conveying water must be routed and fastened in such a way that they pose no temperature risk to man, animals or material sensitive to temperature from radiation / direct contact.
- Before working on the coolant circuit, switch the heater off and wait until all components have cooled down completely, if necessary where safety gloves.

Please note!

- When installing the heater, please take note of the direction of flow of the coolant circuit.
- Fill the heater and water hoses with coolant before connecting to the coolant circuit.
- Route the water hoses without any kinks, and in a rising position if possible.
- When routing the water pipes, observe a sufficient clearance to hot vehicle parts.
- Protect all water hoses / water pipes from chafing and from extreme temperatures.
- Secure all hose connections with hose clips (tightening torque = 1.5 Nm).
- After the vehicle has been operating for 2 hours or travelled 100 km, tighten the hose clips again.
- The minimum water flow rate is only guaranteed if the temperature difference of the heating medium does not exceed 10 K between water inlet and water outlet during heating.
- Only overpressure valves with an opening pressure of min. 0.4 – max. 2 bar may be used in the coolant circuit.
- The coolant liquid must contain at least 10 % antifreeze all year round as corrosion protection.
- The cooling liquid must contain sufficient antifreeze for low temperatures.
- Before commissioning the heater or after changing the cooling liquid, the whole coolant circuit including heater must be vented free of bubbles according to the instructions issued by the vehicle manufacturer.
- Only top up with coolant approved by the vehicle manufacturer.



3 Installation

Connection to the cooling water circuit

Integrate the heater in the water feed pipe from the vehicle engine to the heat exchanger "inline connection"

Disconnect the water feed pipe from the vehicle engine to the vehicle heat exchanger. Connect up the heater with connection pieces and water hoses to the water feed pipe.

Heating characteristics

When the heater is switched on, the heat flows through the vehicle heat exchanger and the vehicle engine. Once the cooling water has reached a temperature of approx. 30 °C, depending on the selected fan setting the vehicle fan is switched on and the heat is also conveyed to the passenger compartment.

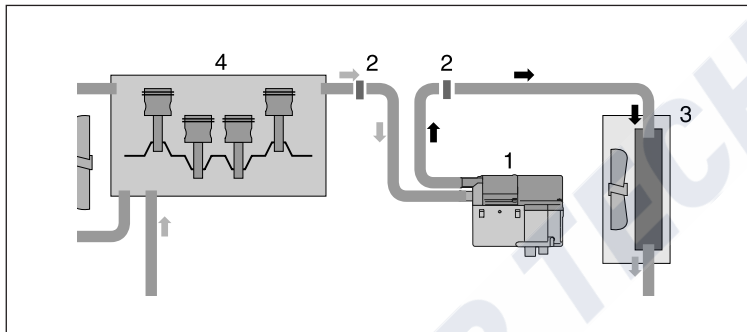

- 1 Heater
- 2 Connection piece
- 3 Heat exchanger
- 4 Vehicle engine

Integrate the heater, water pump and non-return valve in the cooling water circuit

Disconnect the water feed pipe from the vehicle engine to the vehicle heat exchanger and insert the non-return valve. Connect up the heater to the non-return valve using the water hoses.

Heating characteristics

When the heater is switched on, the heat flows through the vehicle heat exchanger only to the vehicle engine. Once the cooling water has reached a temperature of approx. 30 °C, depending on the selected fan setting the vehicle fan is switched on and the heat is also conveyed to the passenger compartment.

Advantage compared to "inline connection" cooling water circuit

No loss of efficiency in the vehicle heating when the heater is switched off.

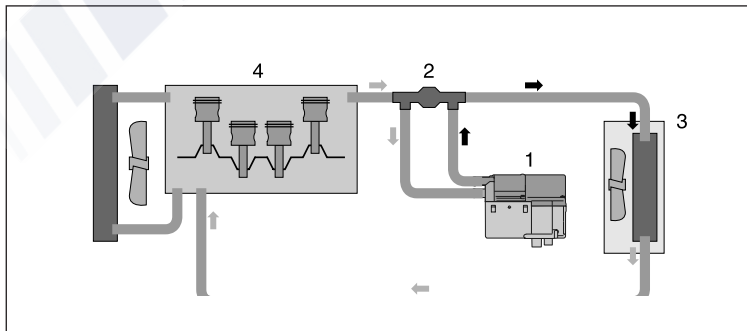

Please note!

Non-return valve must be ordered separately, see additional parts catalogue for Order No.

- 1 Heater
- 2 Non-return valve
- 3 Heat exchanger
- 4 Vehicle engine

3 Installation

Connection to the cooling water circuit

Integrate the heater, water pump, non-return valve, thermostat and T-piece in the cooling water circuit

Disconnect the water feed pipe from the vehicle engine to the vehicle heat exchanger and insert the non-return valve.

Disconnect the water return pipe from the heat exchanger to the vehicle engine and insert the T-piece.

Connect the heater and thermostat with water hoses to the non-return valve and T-piece as shown in the diagram.

Heating characteristics

Small coolant circuit

Fast heating of the passenger compartment. Initially the heat produced by the heater is only conveyed to the heat exchanger up to a cooling water temperature of approx. 70 °C. This heats the passenger compartment up quickly.

Large cooling water circuit

If the cooling water temperature continues to increase, the thermostat slowly changes over to the large circuit (full change-over at approx. 75 °C). This heats the passenger compartment up and also allows for engine pre-heating.

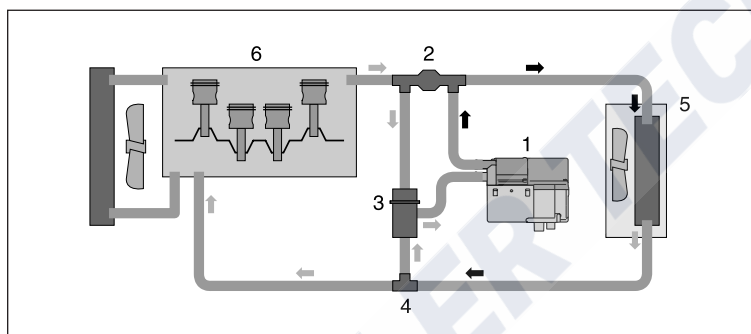

- 1 Heater
- 2 Non-return valve
- 3 Thermostat
- 4 T-piece
- 5 Heat exchanger
- 6 Vehicle engine

Please note!

The thermostat, non-return valve and T-piece must be ordered separately, see additional parts catalogue for Order No.

Thermostat functions

Cooling water temperature < 70 °C – small coolant circuit:

Connection no. 1 – open to the heater

Connection no. 2 – open to the T-piece

Connection no. 3 – closed to the non-return valve

Cooling water temperature > 75 °C – large coolant circuit:

Connection no. 1 – open (to the heater)

Connection no. 2 – closed (to the T-piece)

Connection no. 3 – open (to the non-return valve)

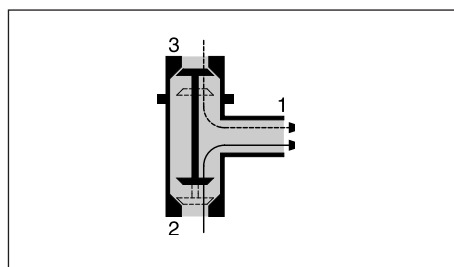

- 1 Connection to the heater
- 2 Connection to the T-piece
- 3 Connection to the non-return valve

Please note!

Integrate the thermostat into the water circuit with connections ① ② and ③ as shown in the diagram.



3 Installation

Connection to the coolant circuit

Integrate the heater, water pump and combination valve with thermostat function in the cooling water circuit.

Combination valve with 5 connections

Order no. 25 2014 80 72 00

If the water feed pipe and water return pipe from the vehicle engine to the heat exchanger are installed separately, the combination valve with 5 connections and an additional T-piece has to be used.

Combination valve with 6 connections

Order no. 25 2014 80 62 00

If the water feed pipe and water return pipe from the vehicle engine to the heat exchanger are installed in parallel, the combination valve with 6 connections (without T-piece) can be used.

Heating characteristics in parking heater mode

Small cooling water circuit with heat discharge in the vehicle's interior.

Initially, up to a cooling water temperature of approx 67 °C, the heat from the heater is only fed to the heat exchanger - inside of the vehicle heats up fast.

Small cooling water circuit with heat discharge at the vehicle's engine.

From a cooling water temperature of around 67 °C, part of the heater's heat is also fed to the vehicle's engine. This slowly heats the engine circuit, without causing the „small cooling water circuit“ for heating the vehicle's interior to rapidly cool down.

Heating characteristics in independent heater mode

Large cooling water circuit

When the vehicle's engine is running the heat is uniformly distributed to the heat exchanger and vehicle engine - further shortening of the warm-up phase and heating up of the inside of the vehicle.

Install combination valve with 5 connections

Disconnect the water feed pipe from the vehicle engine to the vehicle heat exchanger and insert the combination valve.

Disconnect the water return pipe from the heat exchanger to the vehicle engine and insert the T-piece.

Connect the heater to the combination valve and T-piece with the water hoses, as shown in the drawing.

Install combination valve with 6 connections

Disconnect the water feed pipe and the water return pipe from the vehicle engine to the vehicle heat exchanger and insert the combination valve.

Connect the heater to the combination valve with the water hoses, as shown in the drawing.

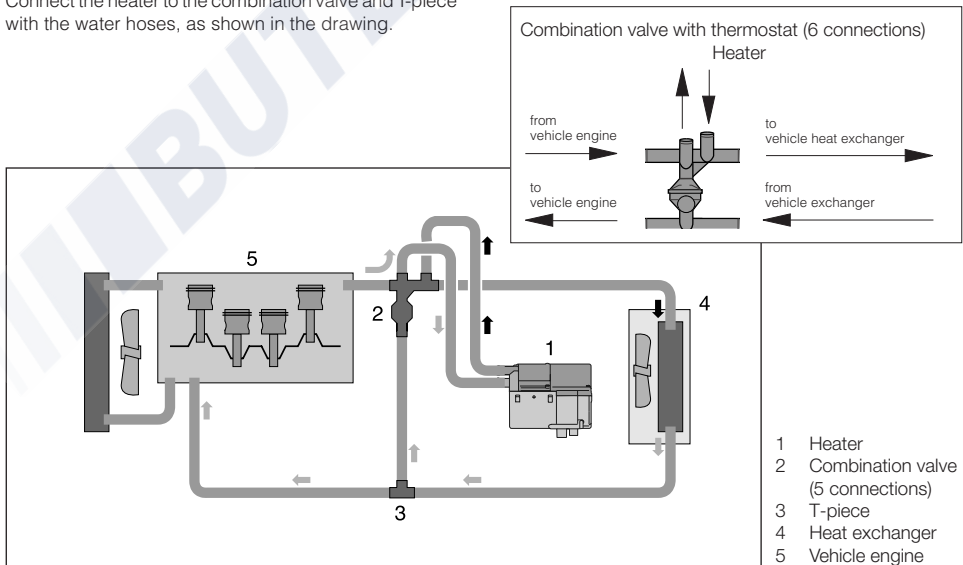

3 Installation

Exhaust system

(Exhaust diagram see page 23)

Mounting the exhaust system

A flexible exhaust pipe, inner \varnothing 24 mm and an exhaust silencer are absolutely necessary for the installation.

The flexible exhaust pipe can be shortened to 20 cm or lengthened to max. 2 m (including exhaust silencer) according to the installation conditions.

Fasten the exhaust silencer to a suitable position in the vehicle. Route the flexible exhaust pipe from the heater to the exhaust silencer and fasten with pipe clips. Use a pipe clip to fix a short exhaust pipe end (with end sleeve) to the exhaust silencer.

Caution!

Safety instructions!

The whole exhaust system gets very hot during and immediately after the heater has been working in the heating mode. This is why the exhaust system must be routed according to these installation instructions.

- The exhaust outlet must end in the open air.
- The exhaust pipe must not protrude beyond the lateral limits of the vehicle.
- Install the exhaust pipe sloping slightly downwards. If necessary, make a drain hole approx. \varnothing 5 mm at the lowest point to drain off condensation.
- Important functional parts of the vehicle must not be impaired (keep sufficient clearance).
- Mount the exhaust pipe with sufficient clearance to heat-sensitive parts. Pay particular attention to fuel pipes (plastic or metal), electrical cables and brake hoses etc.!
- Exhaust pipes must be fastened safely (recommended clearance of 50 cm) to avoid damage from vibrations.
- Route the exhaust system so that the emitted fumes are not sucked in with the combustion air.
- The mouth of the exhaust pipe must not get clogged by dirt and snow.
- The mouth of the exhaust pipe must not point in the direction of travel.
- Always fasten the exhaust silencer to the vehicle.

Danger!

Risk of injuries and burns!

Every type of combustion produces high temperatures and toxic exhaust fumes. This is the reason why the exhaust system must be installed according to these instructions.

- Do not perform any work on the exhaust system while the heater is working.
- Before working on the exhaust system, first switch the heater off and wait until all parts have cooled down completely, wear safety gloves if necessary.
- Do not inhale exhaust fumes.

Please note!

- Comply with the regulations and safety instructions for this chapter on page 4 – 7.
- If a silencer is fitted, the exhaust end pipe must be much shorter than the flexible exhaust pipe between the heater and the exhaust silencer.



3 Installation

Combustion air system

Mounting the combustion air system

The heater is mounted in the engine compartment, as described in these instructions.

If the intake connection for combustion air is in a position where the combustion air can be expected to be no warmer than 25 °C and whether neither splashed water nor dust/dirt are expected, then no combustion air hose is required.

Otherwise a flexible combustion hose must be mounted with an inner Ø 20 mm and up to 1.5 m long, to ensure that the intake of combustion air comes from an area which complies with the above conditions.



Caution!

Safety instructions for the combustion air system

- The combustion air opening must be free at all times.
- Position the combustion air intake to be sure that exhaust fumes cannot be sucked in with the combustion air.
- Do not arrange the combustion air intake to pointing against the wind blast.
- The combustion air intake must not get clogged with dirt and snow.
- Install the combustion air intake system sloping slightly downwards. If necessary, make a drain hole approx. Ø 5 mm at the lowest point to drain off condensation.

Please note!

Comply with the regulations and safety instructions for this chapter on page 4 – 7.

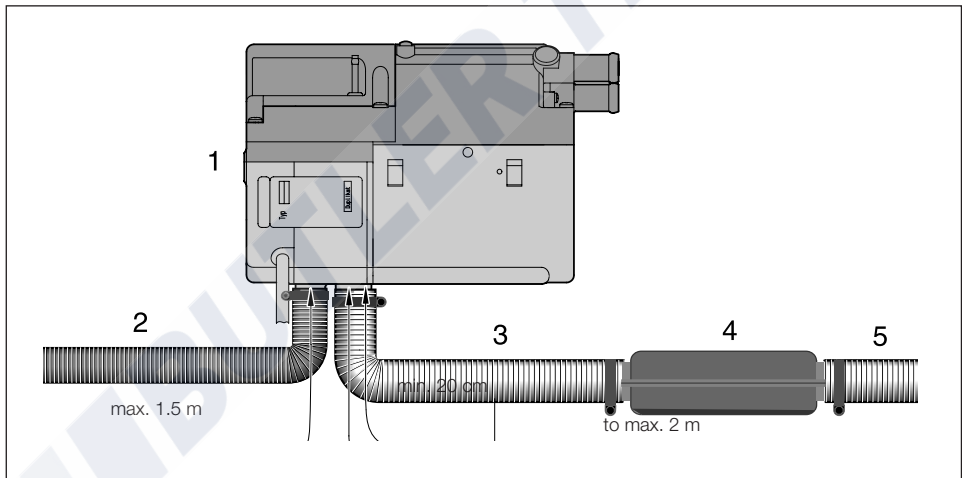

- 1 Heater
- 2 Combustion air pipe
- 3 Exhaust pipe
- 4 Exhaust silencer
- 5 Exhaust pipe end with end sleeve

3 Installation

Fuel supply

Mounting the dosing pump, routing the fuel pipes and mounting the fuel tank

The following safety instructions must be observed when mounting the dosing pump, routing the fuel pipes and mounting the fuel tank.

Deviations from the instructions stated here are not allowed.

Failure to comply can result in malfunctions.



Danger!

Risk of fire, explosion, poisoning and injuries!

Caution when handling fuel.

- Switch off the vehicle engine and heater before refuelling and before working on the fuel supply.
- No naked lights when handling fuel.
- Do not smoke.
- Do not inhale fuel vapours.
- Avoid any contact with the skin.



Caution!

Safety instructions for routing the fuel pipes!

- Only use a sharp knife to cut off fuel hoses and pipes. Interfaces must not be crushed and must be free of burrs.
- The fuel pipe from the dosing pump to the heater should be routed at a continuous rise.
- Fuel pipes must be fastened safely to avoid any damage and / or noise production from vibrations (recommended clearance of approx. 50 cm).

- Fuel pipes must be protected from any mechanical damage.

- Route the fuel pipes so that any distortion of the vehicle, engine movements etc. cannot have any lasting effect on the service life.

- Parts carrying fuel must be protected from interfering heat.

- Never route or fasten the fuel pipes to the heater or vehicle exhaust system. When the systems cross, always ensure there is a sufficient heat clearance. If necessary, install heat deflection plates.

- Dripping or evaporating fuel must never be allowed to collect on hot parts or ignite on electric systems.

- When connecting fuel pipes with a fuel hose, always mount the fuel pipes in a butt joint to prevent any bubbles from forming.

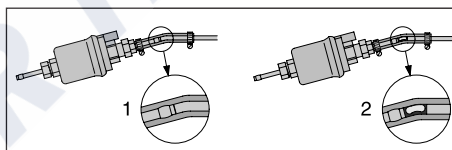

1 Correct connection

2 Incorrect connection – bubble formation

Safety instructions for fuel pipes and fuel tanks in buses and coaches

- In buses and coaches, fuel pipes and fuel tanks must not be routed through the passenger compartment or driver's cab.
- Fuel tanks in buses and coaches must be positioned in such a way that the exits are not in direct danger from a possible fire.

Please note!

Comply with the regulations and safety instructions for this chapter on page 4 – 7.



3 Installation

Fuel supply for petrol heaters

Fuel feed point with T-piece from the fuel supply line from the tank fitting to the vehicle engine

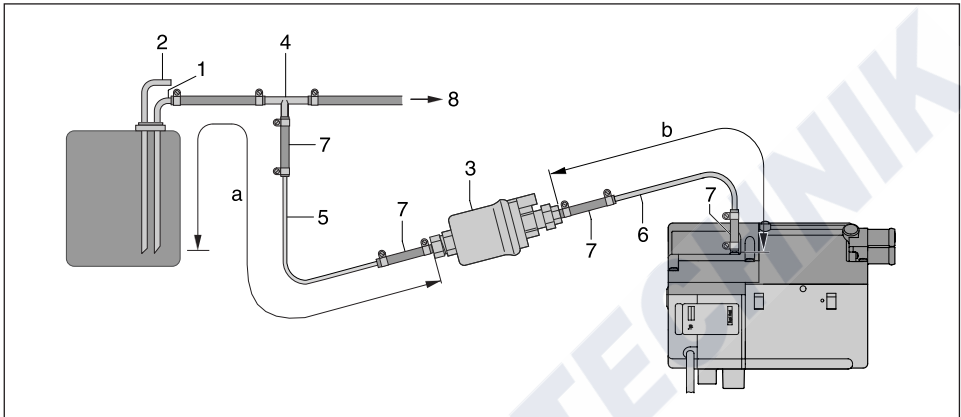

- 1 Fuel feed pipe from tank connection – insert T-piece before the fuel pump in the fuel feed pipe.
- 2 Fuel return pipe to the tank connection
- 3 Dosing pump
- 4 T-piece, 8-6-8
- 5 Fuel pipe, 4 x 1 (di = Ø 2 mm)
- 6 Fuel pipe, 4 x 1.25 (di = Ø 1.5 mm)
- 7 Fuel hose, 3,5 x 3 (di = Ø 3.5 mm), approx. 50 mm long
- 8 To the engine, mechanical fuel or injection pump.

Possible pipe lengths

Intake side
a = max. 2 m

Pressure side
b = max. 4 m

Please note!

Item [4] is not included in the scope of supply. Please refer to the additional parts catalogue for the Order No.

Installation position of the T-piece

Use the installation positions shown in the diagram when inserting a T-piece.

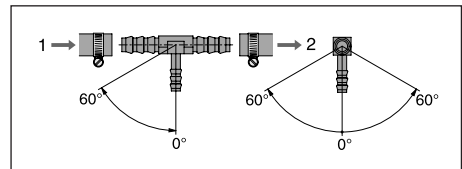

- 1 Direction of flow from the fuel tank
- 2 Direction of flow to the vehicle engine

3 Installation

Fuel supply for petrol heaters

Fuel feed point with tank connection – ascending pipe, integrated in the tank fitting

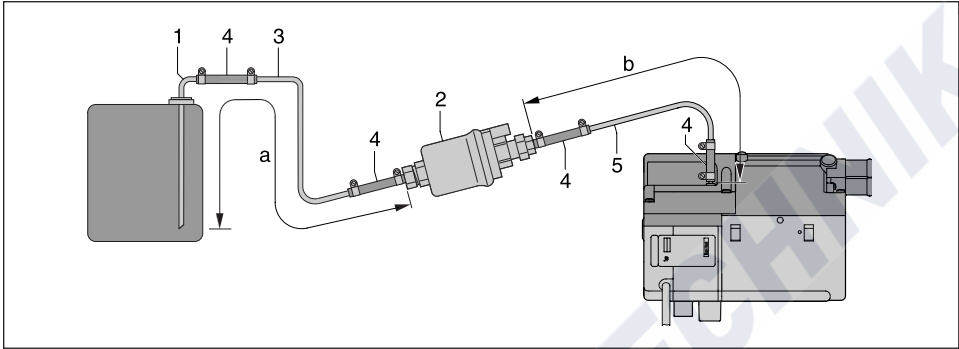

- 1 Tank connection for tank fitting –
di = Ø 2 mm, da = Ø 4 mm
- 2 Dosing pump
- 3 Fuel hose, 4 x 1 (di = Ø 2 mm)
- 4 Fuel hose, 3.5 x 3 (di = Ø 3.5 mm),
approx. 50 mm long
- 5 Fuel pipe, 4 x 1.25 (di = Ø 1.5 mm)

Possible pipe lengths

Intake side
a = max. 2 m

Pressure side
b = max. 4 m

Please note!

When installing tank connection maintain a minimum distance of 50 ± 2 mm from the end of the riser pipe and the bottom of the tank.



Caution!

Safety instructions for the fuel supply!

- The fuel must not be conveyed by gravity or overpressure in the fuel tank.
- Withdrawal of fuel after the vehicle's fuel pump is not allowed.
- When the pressure in the fuel pipe is more than 0.2 bar to max. 4 bar, use a pressure reducer (order no. 22 1000 20 08 00) or separate tank connection.
- When the pressure in the fuel pipe is more than 4 bar or there is a non-return valve in the return pipe (in the tank), a separate tank connection must be used.
- When using a T-piece in a plastic pipe, always use support sleeves in the plastic. Connect the T-piece and the plastic pipe with corresponding fuel hoses and secure with hose clips.



3 Installation

Fuel supply for petrol heaters

Installation position of the dosing pump

Always mount the dosing pump with the pressure side rising upwards. Every installation position over 15° is allowed, although an installation position between 15° and 35° is preferable.

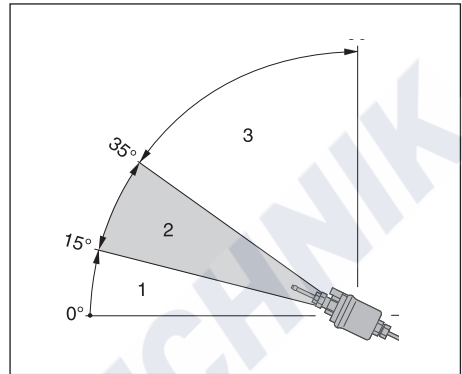

- 1 Installation position between 0° and 15° is not allowed
- 2 Preferred installation position in range 15° to 35°
- 3 Installation position in range 35° to 90° is allowed

Possible suction and pressure height of the dosing pump

Pressure height from vehicle tank to dosing pump:
a = max. 3000 mm

Intake height in pressure-less vehicle tank:
b = max. 500 mm

Intake height in vehicle tanks with withdrawal by negative pressure (valve with 0.03 bar in tank cap):
b = max. 150 mm

Pressure height of the dosing pump to the heater:
c = max. 2000 mm

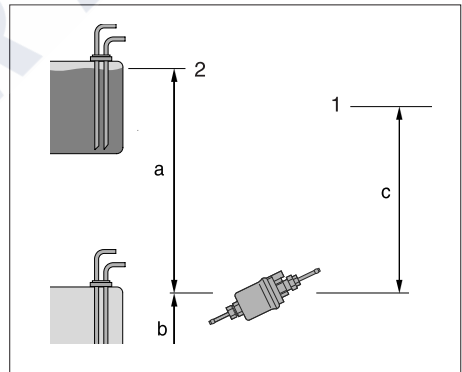

- 1 Connection to heater
- 2 Max. fuel level
- 3 Min. fuel level

Please note!

Check tank venting.

Caution!

Safety instructions for installing the dosing pump

- Always mount the dosing pump with the pressure side rising upwards – minimum incline 15°.
- Protect the dosing pump and filter from intolerable heat, do not mount near to the silencers and exhaust pipes.

3 Installation

Fuel supply for diesel heaters

Fuel feed point with T-piece from the fuel supply line from the tank fitting to the vehicle engine.

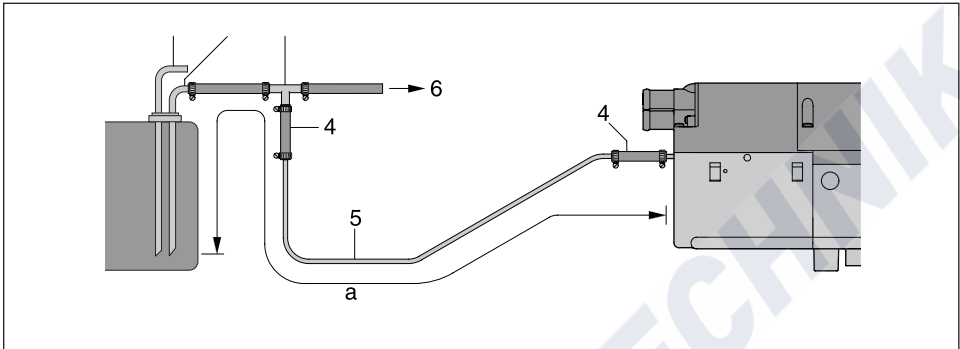

- 1 Fuel return pipe from the tank connection
- 2 Fuel feed pipe from tank connection – insert T-piece before the fuel pump in the fuel feed pipe.
- 3 T-piece
- 4 Fuel hose, 3.5 x 3 (di = Ø 3.5 mm) approx. 50 mm long
- 5 Fuel pipe, 4 x 1 (di = Ø 2 mm)
- 6 To the engine, mechanical fuel or injection pump.

Possible pipe lengths

Intake side
a = max. 5 m

Please note!

Item (3) is not included in the scope of supply. Please refer to the additional parts catalogue for the Order No.

Installation position of the T-piece

Use the installation positions shown in the diagram when inserting a T-piece.

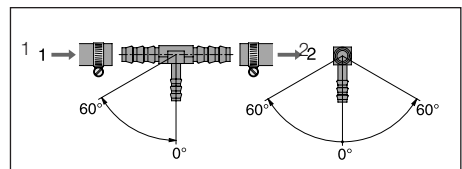

- 1 Direction of flow from the fuel tank
- 2 Direction of flow to the vehicle engine



3 Installation

Fuel supply for diesel heaters

Fuel feed point with ascending pipe in the tank connection, integrated in the vehicle tank or in the tank fitting

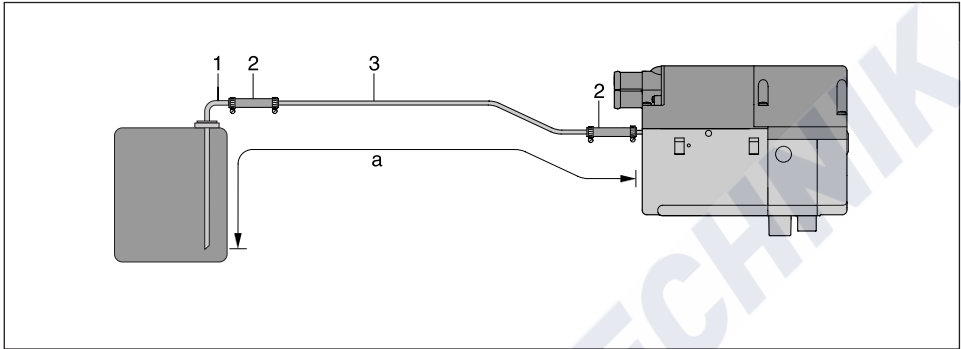

- 1 Tank connection for tank fitting, $d_i = \text{Ø } 2 \text{ mm}$, $d_a = \text{Ø } 4 \text{ mm}$
- 2 Fuel hose, 3,5 x 3 ($d_i = \text{Ø } 3.5 \text{ mm}$), approx. 50 mm long
- 3 Fuel pipe, 4 x 1 ($d_i = \text{Ø } 2 \text{ mm}$)

Possible pipe length:

Intake side:
a = max. 5 m

Please note!

When installing tank connection maintain a minimum distance of $50 \pm 2 \text{ mm}$ from the end of the riser pipe and the bottom of the tank.

Possible intake and pressure height:

Pressure height from vehicle tank to heater:
a = max. 3000 mm

Suction height for pressure-free vehicle tank:
b = max. 1000 mm

Suction height for a vehicle tank with withdrawal under negative pressure (valve with 0.03 bar in tank cap):
b = max. 400 mm

Please note!

Check tank venting.

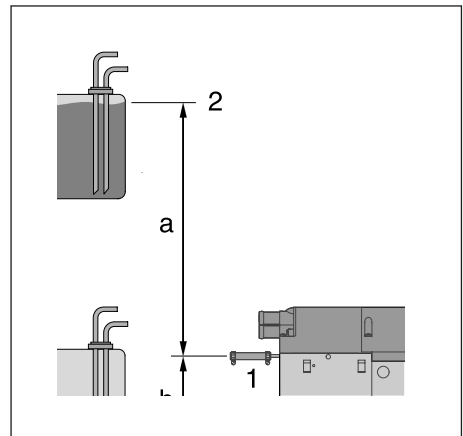

- 1 Connection to heater
- 2 Max. fuel level
- 3 Min. fuel level

3 Installation

Fuel supply

Fuel quality for petrol heaters

The heater can run on commercially available fuel as per DIN EN 228, as used in the vehicle tank.

Fuel quality for diesel heaters

The heater can run on commercially available diesel fuel as per DIN EN 590 as used in the vehicle tank.

Fuel for special cases

In special cases (above 0 °C), the heater can also run on fuel oil EL or paraffin.

Fuel for low temperatures

Refineries and fuel service stations automatically adjust the fuel to normal winter temperatures (winter diesel). This means that difficulties are only to be expected for extreme drops in temperature, as also apply to the vehicle engine. Please also refer to the vehicle manual.

If the heater is run from a separate tank, please comply with the following rules:

For temperatures above 0 °C, any kind of diesel fuel as per DIN EN 590 can be used.

If no special diesel fuel is available for low temperatures, then paraffin or petrol should be mixed with the fuel according to the following table:

Temperature	Winterdiesel	Addition
0 °C to -25 °C	100 %	-
-25 °C to -40 °C	50 %*	50 % paraffin or petrol

* or 100 % special cold diesel fuel (Arctic diesel)

Please note!

- Mixtures with used oil are **not** allowed!
- After refuelling with winter or cold diesel or the listed blends, the fuel pipes and the dosing pump must be filled with the new fuel by letting the heater run for 15 mins.!

Operation with biodiesel (PME)

The heater is **not** certified for operation with biodiesel.