

HYDRONIC D5W S

Troubleshooting and repair instructions

Eberspächer

EN

Eberspächer Climate
Control Systems
GmbH & Co. KG
Eberspächerstr. 24
73730 Esslingen
Germany

www.eberspaecher.com
info@eberspaecher.com

**The troubleshooting and repair instructions are valid
for the following engine-independent water heaters:**

Heaters for petrol

	Order No.
B 4 W S FL – 12 volt	20 1852 01 00 00
B 5 W S – 12 volt	20 1819 01 00 00

Heaters for diesel

	Order No.
D 4 W S FL – 12 volt	25 2355 01 00 00
D 5 W S – 12 volt	25 2217 01 00 00
D 5 W S – 24 volt	25 2218 05 00 00

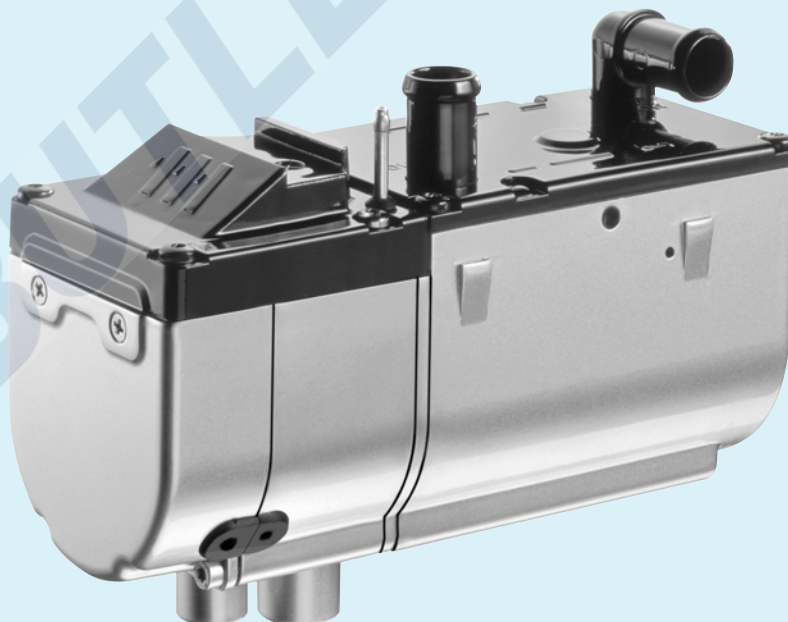

1 Introduction

Contents

These contents provide you with the exact information about the contents of the troubleshooting and repair instructions.

If you are looking for a phrase or technical term or need an explanation for an abbreviation, please use the corresponding index at the end of the instructions from page 56.

Chapter	Chapter title	Chapter contents	Page
1	Introduction	<ul style="list-style-type: none"> • Special forms of notation, presentation and icons 4 • Liability / Guarantee 4 • Accident prevention 4 • Important information <ul style="list-style-type: none"> – Range of application of <i>HYDRONIC</i> 5 – Purpose of <i>HYDRONIC</i> 5 – Initial commissioning of <i>HYDRONIC</i> respectively function test following repairs 5 • <i>HYDRONIC</i> documentation <ul style="list-style-type: none"> – Contents and purpose of these troubleshooting and repair instructions 5 – Other <i>HYDRONIC</i> documentation 5 • Statutory regulations 6 <ul style="list-style-type: none"> – Regulations for installation and repair 6 – Regulations for operation 6 • Safety instructions for installation and repair of <i>HYDRONIC</i> 7 • Safety instructions for operation 7 <ul style="list-style-type: none"> – Emergency shut-down (EMERGENCY OFF) 7 	
2	Function and operation	<ul style="list-style-type: none"> • Sectional drawing <i>HYDRONIC</i> B 5 W S 8 • Function diagram <i>HYDRONIC</i> B 5 W S 9 • Control diagram <i>HYDRONIC</i> B 5 W S 9 • Sectional drawing <i>HYDRONIC</i> D 5 W S 10 • Function diagram <i>HYDRONIC</i> D 5 W S 11 • Control diagram <i>HYDRONIC</i> D 5 W S 11 • Description of functions 12 • Control and safety features 12 	
3	Technical data	<ul style="list-style-type: none"> • <i>HYDRONIC</i> 13 • Water pump 14 	
4	Troubleshooting	<ul style="list-style-type: none"> • When faults occur, first check 15 • Controller lock 15 • Cancel the controller lock 15 • Testing equipment 15 • Testing equipment <ul style="list-style-type: none"> – Diagnosis instrument 16 – Module clock – installed in vehicle 16 – Customer service program KD 2000 16 – Radio remote control TP5 16 • Fault diagnosis with diagnosis instrument 17, 18 • Fault diagnosis with module clock 19 • Fault diagnosis with customer service program KD 2000 20 • Fault diagnosis with radio remote control TP5 21 • Error code table 22 – 26 	



1 Introduction

Chapter	Chapter title	Chapter contents	Page
5	Repair instructions	<ul style="list-style-type: none"> • Repair instructions 27 • Observe following safety instructions before working on the <i>HYDRONIC</i> 27 • Instructions for AMP unlocking tool 27 • Fitting <i>HYDRONIC</i> back into the vehicle 27 • Assembly drawing 28, 29 • Repair step 1 Dismantle fan cover 30 • Repair step 2 Dismantle jacket cover and sockets 30 • Repair step 3 Dismantle controller 31 Check controller 31 • Repair step 4 Remove glow plug 31 • Repair step 5 Remove flame sensor 32 Check flame sensor 32 • Repair step 6a Dismantle combustion air fan 33 • Repair step 6b Measure speed of combustion air fan motor 33 • Repair step 7a Remove plug filter 34 • Repair step 7b Remove socket 34 • Repair step 8 Remove combustion chamber 35 • Repair step 9 Remove overheating and temperature sensor 35 Check overheating and temperature sensor 36 • Repair step 10 Remove heat exchanger 36 • Repair step 11 Re-mount heat exchanger 37 • Measuring the fuel quantity 37 	
6	Wiring diagram	<ul style="list-style-type: none"> • Wiring diagram <i>HYDRONIC</i> B 5 W S / D 5 W S – 12 volt 38, 39 • Wiring diagram Controls – 12 volt, part 1 40, 41 • Wiring diagram Controls – 12 volt, part 2 42, 43 • Wiring diagram <i>HYDRONIC</i> D 5 W S – 24 volt 44, 45 Controls – 24 volt 45 • Wiring diagram <i>HYDRONIC</i> D 5 W S – 24 volt, GGVS / TRS003 / ADR / ADR99 46, 47 Controls – 24 volt, GGVS / TRS003 / ADR / ADR99 47 • Wiring diagram Controls – EasyStart 48 – 52 • Wiring diagram Controls – EasyStart R+ 49 • Wiring diagram Controls – EasyStart R 50 • Wiring diagram Controls – EasyStart T 51 • Wiring diagram Controls – EasyStart T – ADR 52 	
7	Service	<ul style="list-style-type: none"> • Certification 53 • Disposal 53 • List of abbreviations 54 • Keyword index 55 	

1 Introduction

Special forms of notation, presentations and icons

These instructions use special forms of notation and icons to underline various different contents. Please refer to the examples below for the meaning and how to behave.

Special forms of notation and presentations

- This point (•) indicates a list introduced by a heading.
 - If a “dot” is followed by an indented hyphen (–), this list is classified under the black dot.

Icons



Regulation

This icon refers you to a statutory regulation. Failure to comply can possibly lead to the ABG (general type certification) for *HYDRONIC* becoming null and void and to the preclusion of any guarantee or liability on the part of J. Eberspächer GmbH & Co. KG.



Danger

This icon draws your attention to a threat of danger to life and limb. Failure to comply can possibly lead to severe personal injury.

- This arrow refers to the corresponding precautions to be taken to prevent the danger.



Caution

This icon draws your attention to a dangerous situation for a person and / or product. Failure to comply can result in injury to persons or damage to the machine.

- This arrow refers to the corresponding precautions to be taken to prevent the danger.



This draws your attention to recommendations and helpful tips for operation, installation and repair of the *HYDRONIC*.

Liability / guarantee

Compliance with the official regulations and safety instructions is a prerequisite for any liability claims.

Failure to comply with the official regulations and safety instructions precludes any liability on the part of the heater manufacturer.

Accident prevention

General accident prevention regulations and corresponding workshop and operational protection instructions must always be observed.



1 Introduction

Important information

Range of application of *HYDRONIC*

The engine-independent water heater *HYDRONIC* is intended for installation in the following vehicles, depending on heater output:

- motorised vehicles of all kinds
- construction machines
- boats, ships and yachts (diesel heaters only).



Caution

- The heater may only be used and operated for the range of application stated by the manufacturer in full compliance with the “operating instructions” enclosed with every heater.
- *HYDRONIC* B 5 W S / D 5 W S – 12 volt must not be installed in vehicles used for the transport of dangerous substances as per GGVS / TRS003 / ADR / ADR99.
- *HYDRONIC* D 5 W S – 24 volt is certified for use in vehicles used to transport dangerous goods as per GGVS / TRS003 / ADR / ADR99.

Purpose of *HYDRONIC*

- Preheating, de-misting windows
- Heating the following and keeping them warm:
 - Driver or working cab
 - Freight compartments
 - Ship’s cabins
 - Passenger and crew compartments
 - Vehicle engines and additional units.

Given its functional purpose, *HYDRONIC* is **not** certified for the following uses:

- Long-term continuous operation, e.g. pre-heating and heating of:
 - Living areas
 - Garages
 - Working sheds, weekend houses and hunting cottages
 - Houseboats, etc.

Initial commissioning of *HYDRONIC* respectively function test following repairs

- After installation of the heater respectively after repairs to *HYDRONIC*, the coolant circuit and the whole fuel supply system must be carefully vented. Please comply with the instructions issued by the vehicle manufacturer.
- Prior to a trial run, open all heating circuits (set the temperature control to “warm”).
- During the trial run of *HYDRONIC*, check that all water and fuel connections do not leak and are firmly connected.
- If *HYDRONIC* should show a malfunction during operation, eliminate the problem with a diagnosis device.

HYDRONIC Documentation

Content and purpose of these troubleshooting and repair instructions

These instructions are to be used for eliminating faults and performing repairs on *HYDRONIC*.

The necessary work must only be carried out by a JE service partner or correspondingly trained staff.

Other *HYDRONIC* documentation

Operating instructions

The operating instructions give the customer all necessary information for safe operation of *HYDRONIC*.

Technical description / Installation instructions

The technical description/installation instructions give the JE service partner all necessary technical information and describe correct proper installation of *HYDRONIC*.



Spare parts list

The spare parts list gives the JE service partner all necessary information for ordering spare parts required for repair work.

1 Introduction

§ Statutory regulations

For installation in vehicles subject to the German Regulations Authorising the Use of Vehicles for Road Traffic (StVZO), the heater has been awarded a "general type certification (ABG)" with official test symbol marked on the heater nameplate.

HYDRONIC B 5 W S  S 288
HYDRONIC D 5 W S  S 274

The statutory regulations are compulsory in the scope of the StVZO and must also be observed in countries where there are no special regulations.

For installation of the heater in vehicles not subject to the StVZO (e.g. ships), the specially valid regulations and installation instructions must be observed.

§ Regulations for installation and repair

- The year of initial commissioning must be entered indelibly on the nameplate. For this purpose, 3 year numbers are printed on the corresponding section of the nameplate. The respective year number is to be indicated by removing (peeling off) the two inapplicable year numbers.
- The heaters are to be installed according to the installation instructions. Installation is to be checked
 - a) by type testing of the vehicles as per § 20 StVZO
 - b) by individual testing as per § 21 StVZO or
 - c) by a survey as per § 19 StVZO or by an officially approved surveyor or inspector for motorised vehicles, a motorised vehicle surveyor or employee according to section 7.4a of the appendix to StVZO.In the case of c), this is to be certified stating the vehicle manufacturer, vehicle type and vehicle ident. number on the acceptance confirmation contained in the ABG form. Effectiveness of type certification depends on this. The acceptance confirmation must always be kept in the vehicle.
- For installation of the heater in special vehicles (e.g. vehicles for the transport of dangerous goods), the regulations applying to such vehicles must be observed.
- The heater may not be installed in the driver or passenger compartment of buses and coaches with more than 8 seats apart from the driver's seat.
- The sticker "**turn the heater off before refuelling**" included in the scope of supply of the heater must be affixed to a suitable point of the vehicle (near to the fuel filler neck).
- The outlet opening must be designed so that a ball of 16 mm diameter cannot pass through.
- Exhaust pipes must be routed so that any penetration of exhaust inside the vehicle is not to be expected.

- The functioning of important operational parts of the vehicle must not be impaired.
- Condensation or penetrated water must not be allowed to gather in the exhaust pipe. Drain openings are permitted, consisting of impervious pipes in the interior which drain the liquid to the outside.
- The opening of the exhaust pipe should be routed upwards, to the side, or when the exhaust pipe is routed under the bottom of the vehicle, close to the side or rear end of the driver's cab or vehicle.
- The necessary combustion air must be taken in from the outside.
- The opening of the combustion air intake must be designed so that a ball of 16 mm diameter cannot pass through.
- Electrical cables, switchgear and controllers for the heater must be arranged in the vehicle so that troublefree operation is not impaired under normal operating conditions. All pipes leading out from the heaters must be splashproof at the leadthrough.
- The corresponding operating condition (at least switched on or off) must be clearly obvious for the user.
- §§ 45 and 46 StVZO are to be observed for the routing of fuel pipes and installation of additional fuel tanks. Excerpt from §§ 45 and 46 StVZO:
 - In the case of buses and coaches, fuel tanks may not be located in the passenger or driver's compartment. They must be arranged so that the exits from the bus are not at any risk in the case of a fire.
 - In the case of buses and coaches, fuel pipes may not be located in the passenger or driver's compartment.

§ Regulations for operation

- The heater must be switched off when refuelling.
- Operation of the heater is not allowed in closed rooms, such as:
 - garages
 - underground car parks
 - multi-storey car parks.

Please note

- The acceptance confirmation is enclosed with the documents for *HYDRONIC*.



1 Introduction

Safety instructions for installation and repair of *HYDRONIC*



Danger

Risk of injury, burning and fire!

- Disconnect the vehicle battery before starting any work on *HYDRONIC*.
- Always switch *HYDRONIC* off and let all hot parts cool down prior to repairs.



Caution

Important instructions for installation and repair of *HYDRONIC*

- The heater must only be installed by a JE service partner authorised by the manufacturer, according to the specifications made in this document and possibly any special installation suggestions, or repaired in the case of repairs or guarantee claims.
- Repairs by unauthorised third parties and / or with non-original spare parts are dangerous and therefore not allowed. They make the general type certification (ABG) of the heater invalid and thus in the case of motorised vehicles, under certain circumstances also the general operating permit (ABE) of the vehicle.
- The following are not allowed:
 - Modifications to heating-relevant components.
 - Use of third-party components not approved by Eberspächer.
 - Failure during installation or operation to comply with statutory and safety regulations or regulations relevant to function, as stipulated in the installation instructions and operation instructions.
This applies in particular to the electrical wiring (circuit diagrams), fuel supply, combustion air system and exhaust system.
- Only original accessories and original spares may be used for installation or repairs.
- Only the controls approved by Eberspächer may be used to operate *HYDRONIC*.
The use of other controls can cause malfunctions of the heater / heating operation.
- Before installing a heater in another vehicle, those parts of the heater which convey water must be rinsed with clear water.
- Fuel pipes and exhaust pipes must be fastened securely (recommended spacing 50 cm) to avoid damage from vibrations.
- Ensure that the insulation of electric cables etc. cannot be damaged by chafing, buckling, clamping or heat development.

- Failure to comply with the statutory and safety regulations and / or specifications relevant to functions makes the ABG of *HYDRONIC* null and void and releases J. Eberspächer GmbH & Co. KG from any guarantee or liability.

Please note

Other “safety instructions and important information for the installation and repair of *HYDRONIC*” are printed directly in the corresponding sections of these troubleshooting and repair instructions.

Safety instructions for operation



Caution

- The heater may not be operated wherever inflammable fumes or dust can be produced, e.g. near to
 - fuel depots
 - coal depots
 - wood storage yards
 - cereal storage facilities.
- *HYDRONIC*'s after-running feature may not be interrupted prematurely for example by pressing the battery disconnecting switch, apart from in an emergency shut-down.

Emergency shut-down (EMERGENCY STOP)

If during operation an emergency shut-down (EMERGENCY STOP) should be necessary, please proceed as follows:

- Switch *HYDRONIC* off at the controls, or
- Pull the fuse, or
- Open the battery disconnecting switch, or
- Disconnect *HYDRONIC* from the battery.

2 Function and operation

Sectional drawing *HYDRONIC B 5 W S*

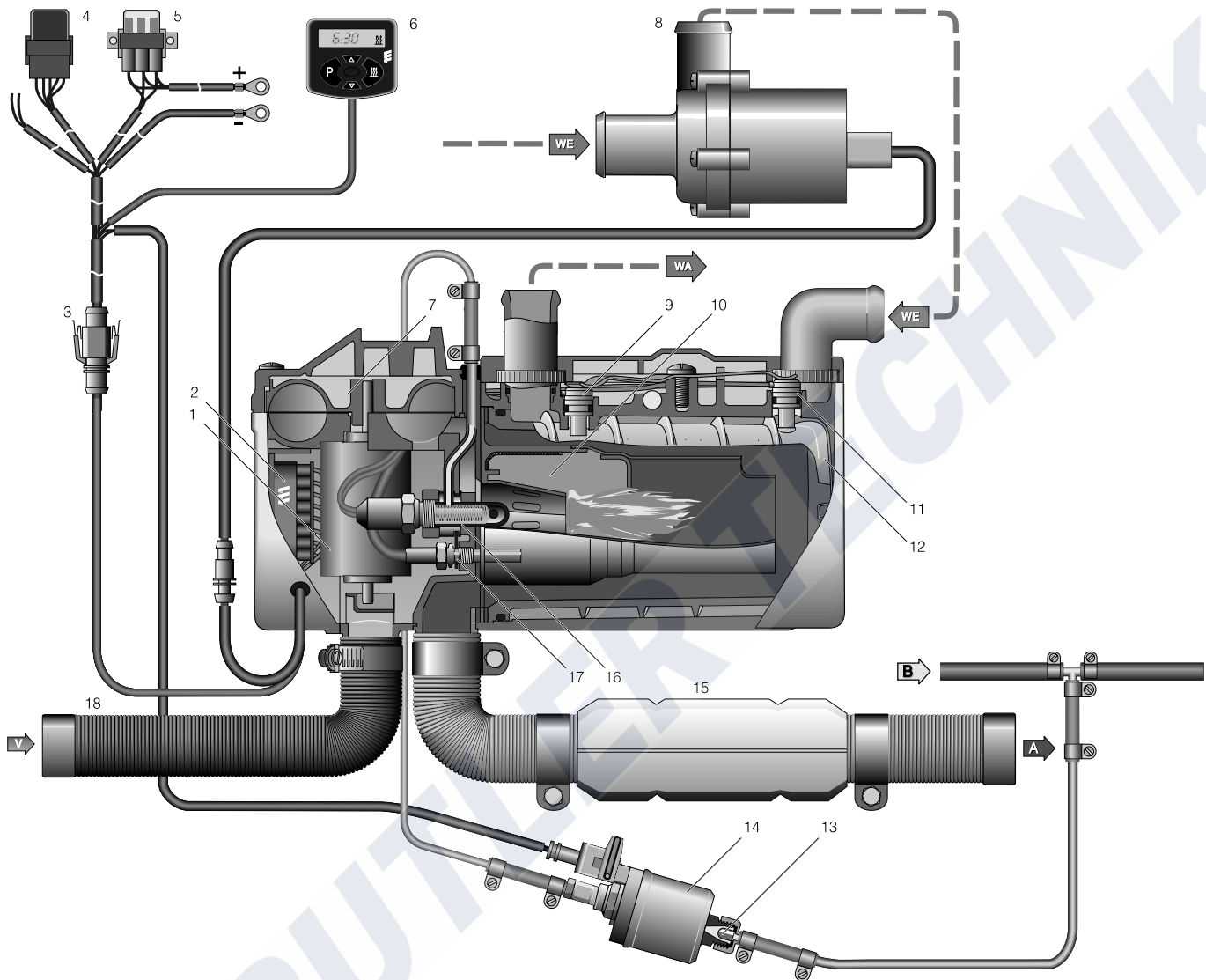

- | | |
|--------------------------------|---------------------------------------|
| 1 Electric motor | 13 Cup filter, fitted in dosing pump |
| 2 Controller | 14 Dosing pump |
| 3 Interface / 8-pole connector | 15 Exhaust pipe with exhaust silencer |
| 4 Fan relay | 16 Glow plug |
| 5 Fuse holder | 17 Flame sensor |
| 6 Mini timer | 18 Combustion air pipe |
| 7 Combustion air fan | |
| 8 Water pump | |
| 9 Temperature sensor | |
| 10 Combustion chamber | |
| 11 Overheating sensor | |
| 12 Heat exchanger | |
- A = exhaust
 B = fuel
 C = combustion air
 WA = water discharge
 WE = water intake



2 Function and operation

Function diagram – HYDRONIC B 5 W S

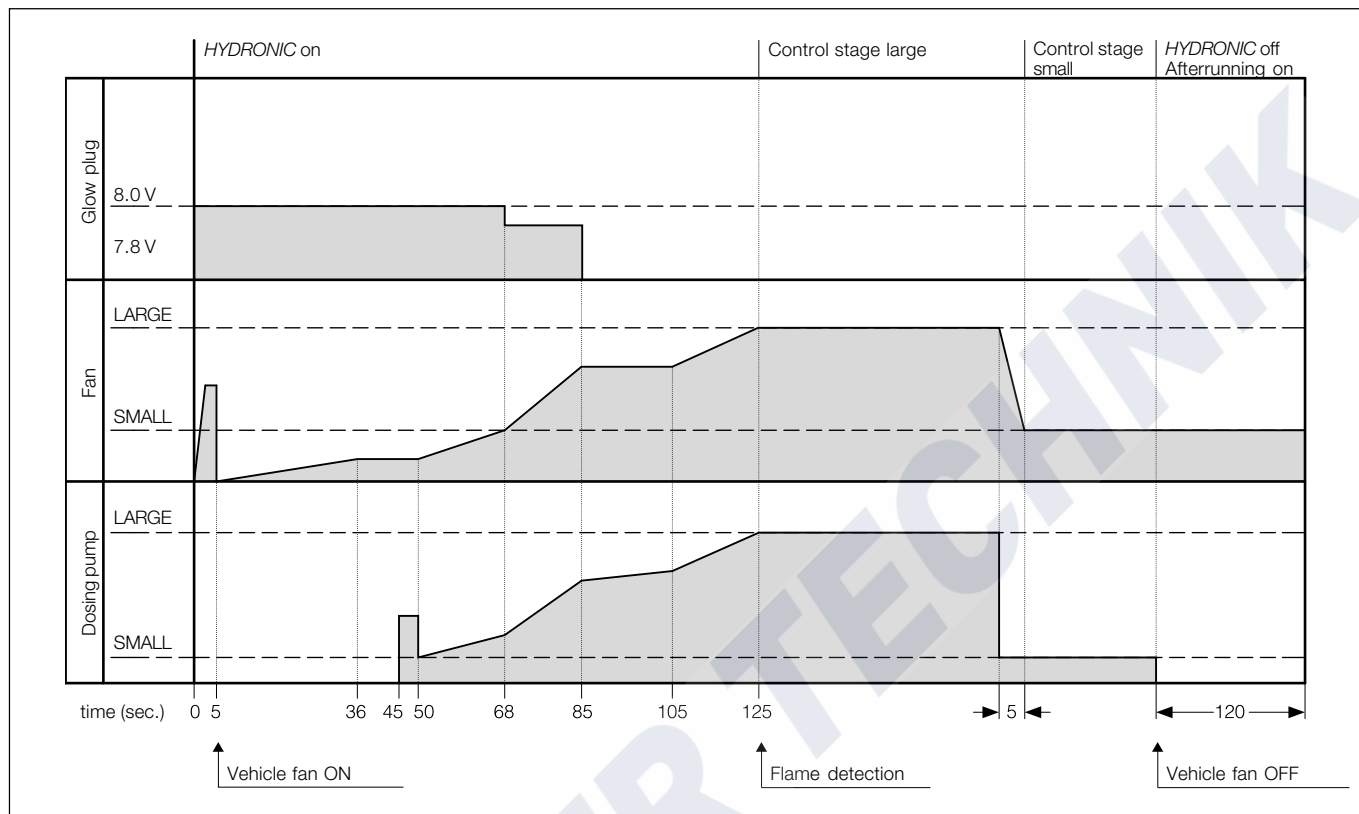

Sectional drawing – HYDRONIC B 5 W S

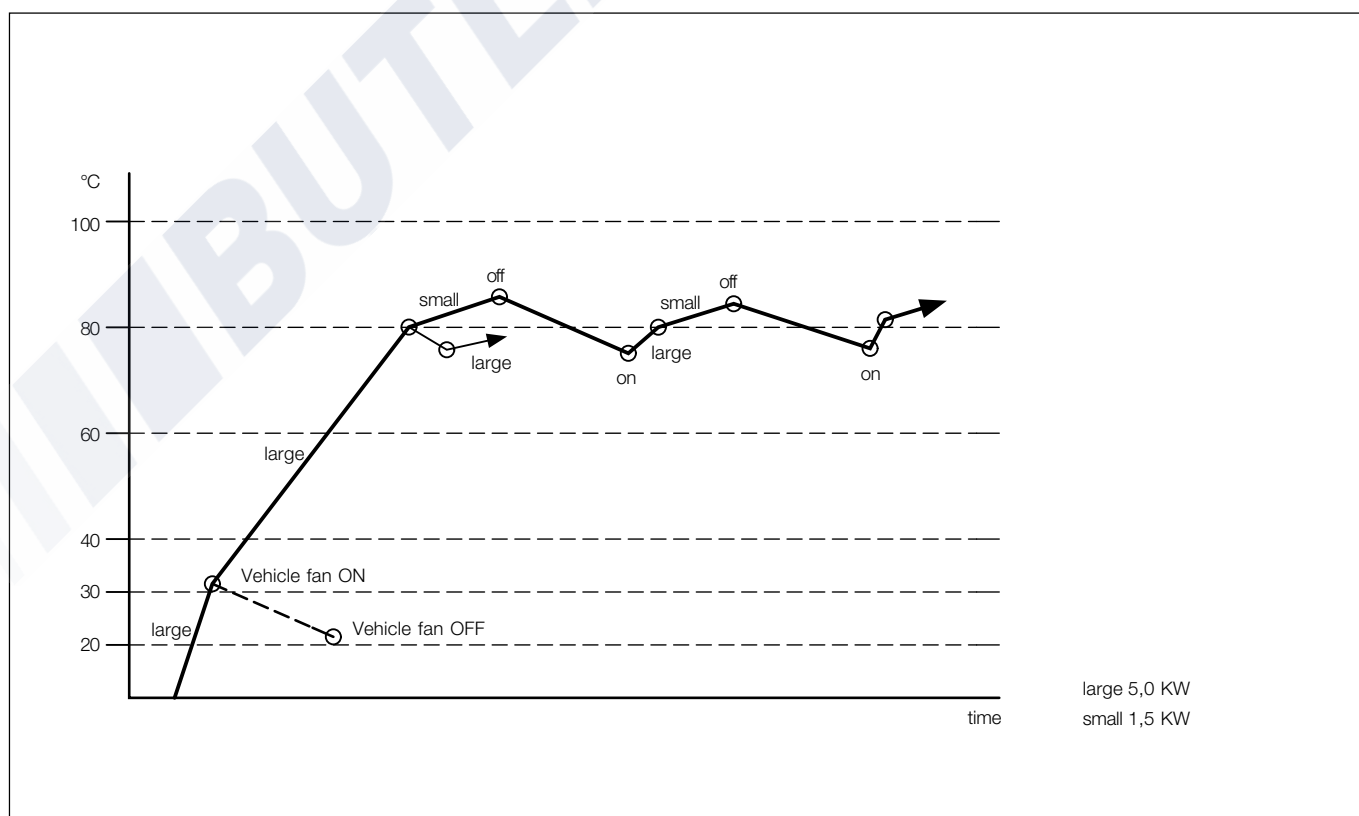

2 Function and operation

Sectional drawing *HYDRONIC D 5 W S*

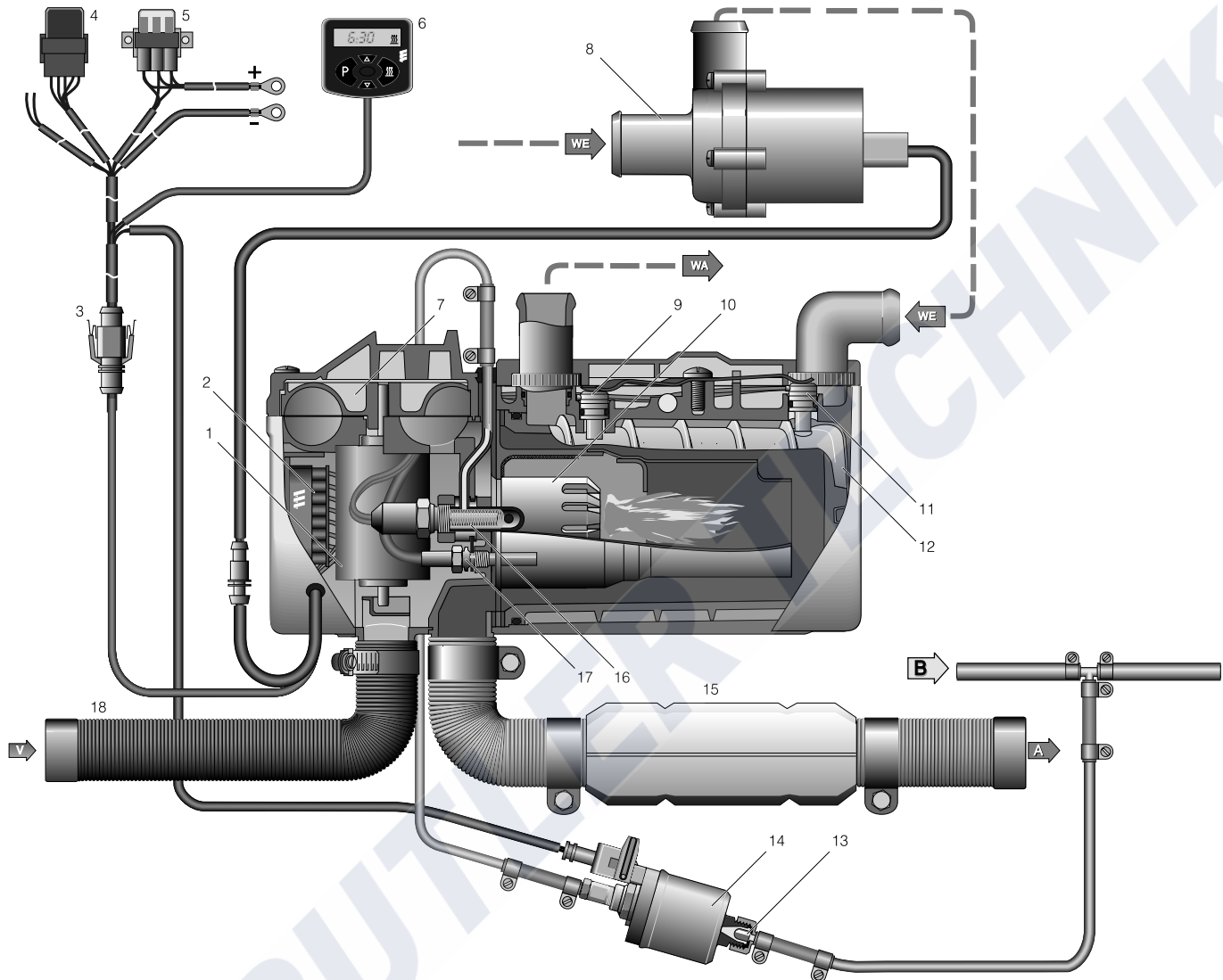

- | | |
|--------------------------------|---------------------------------------|
| 1 Electric motor | 13 Cup filter, fitted in dosing pump |
| 2 Controller | 14 Dosing pump |
| 3 Interface / 8-pole connector | 15 Exhaust pipe with exhaust silencer |
| 4 Fan relay | 16 Glow plug |
| 5 Fuse holder | 17 Flame sensor |
| 6 Mini timer | 18 Combustion air pipe |
| 7 Combustion air fan | |
| 8 Water pump | A = exhaust |
| 9 Temperature sensor | B = fuel |
| 10 Combustion chamber | C = combustion air |
| 11 Overheating sensor | WA = water discharge |
| 12 Heat exchanger | WE = water intake |



2 Function and operation

Function diagram – HYDRONIC D 5 W S

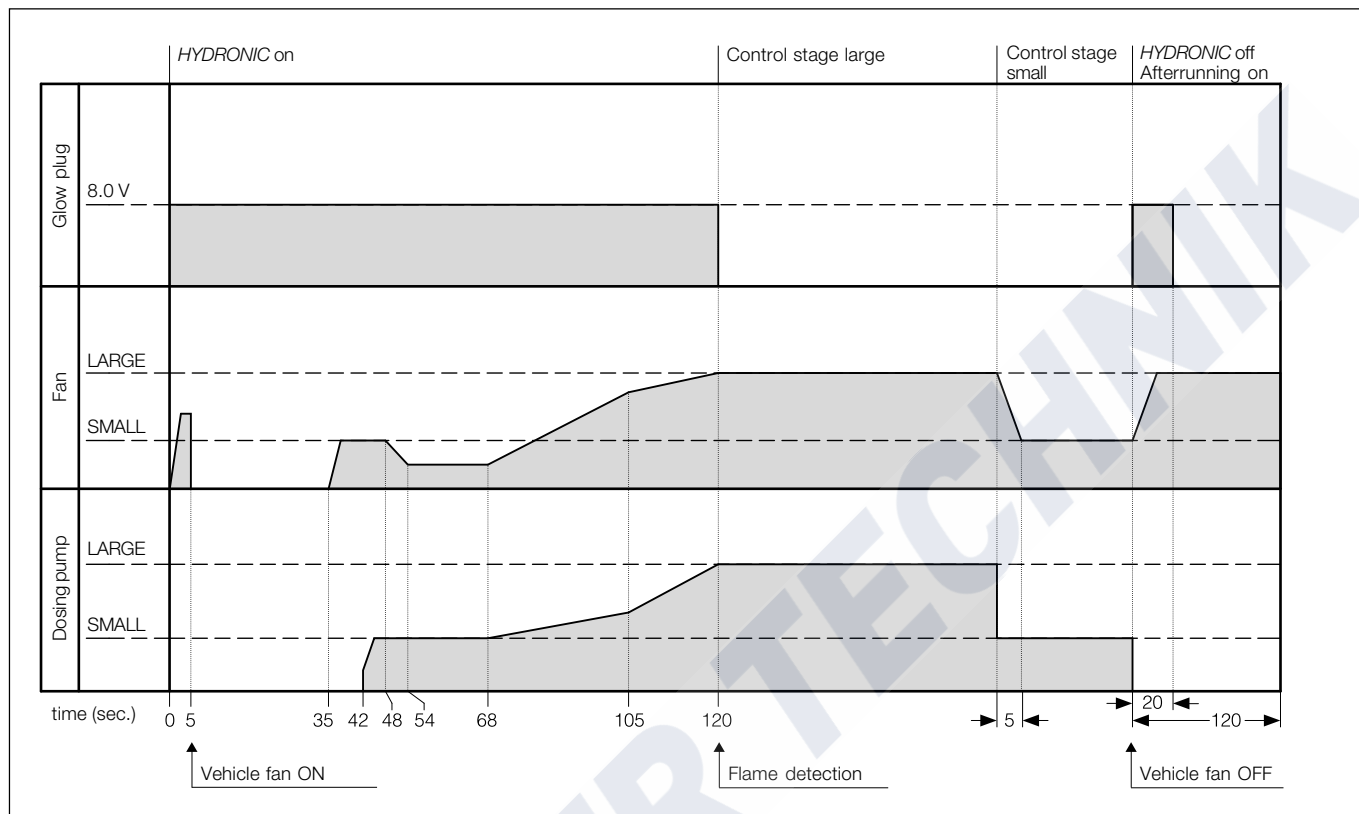

Sectional drawing – HYDRONIC D 5 W S

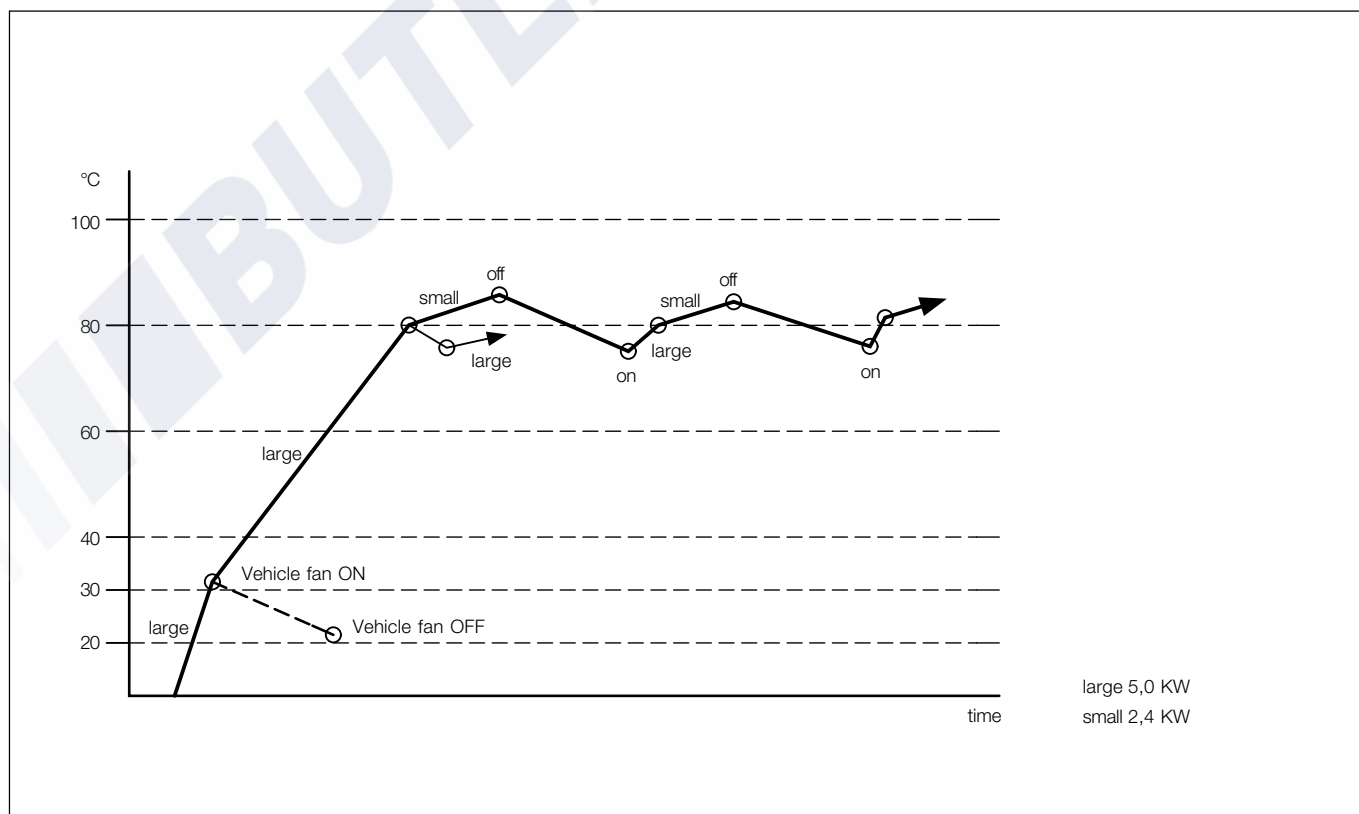

2 Function and operation

Description of functions

Depending on the way it is connected up, *HYDRONIC* can be operated as pure pre-heater or combined pre- and additional heater, to compensate for the low heat emission of the vehicle engine.

Pre-heating mode

Switching on

When the heater is switched on, the operating display in the control unit (mini timer, module clock...) lights up. The water pump starts up. The combustion air fan, glow plug and fuel dosing pump then start the combustion procedure according to a certain program, with pre-rinsing and pre-heating. Once a stable flame has formed, the time control switches the glow plug off.

Heating mode

Depending on the heat requirements, *HYDRONIC* is controlled in the stages:

LARGE
SMALL
OFF (control pause).

The temperature thresholds are permanently programmed in the electronic controller.

If the heat required in the "SMALL" stage is so low that the cooling water temperature reaches 85°C, then the control switches to the control pause. This is followed by approx. 130 seconds after-running. The operating display is still on and the water pump also continues to run during the control pause.

Pre-venting with changeover switch "heating / venting"

Pre-venting means triggering the vehicle fan directly by the heater pre-selection timer or, even more appropriate, by a remote control bypassing the heater. In this way in summer months when the insides of a vehicle get heated up when standing in the sunshine, it is possible to allow fresh air to vent the vehicle (separate circuit).

Compulsory shut-down in operation for GGVS / TRS003 / ADR / ADR99 – *HYDRONIC D 5 W S – 24 volt only*

When operating in vehicles for the transport of dangerous goods (e.g. tanker vehicles), *HYDRONIC* must be switched off before driving into a hazard area (refinery, fuelling station, etc.).

On failure to comply with this requirement, *HYDRONIC* switches off automatically when

- the vehicle engine is switched off,
- an additional unit is switched on (auxiliary drive for discharging pump, etc.),
- a vehicle door is opened (in France only).

The fan runs on briefly for approx. 40 seconds.

Control and safety features

- If *HYDRONIC* fails to ignite within 90 seconds after fuel pumping starts, the start procedure is repeated as described.
If after a further 90 seconds fuel pumping *HYDRONIC* still fails to ignite, the heater is switched off in fault mode. The controller is locked after a certain number of failed starts*.
- If the flame does out by itself during operation, firstly a new start is activated. If *HYDRONIC* fails to ignite within 90 seconds after fuel pumping has started again, or ignites but goes out again within 15 minutes, the heater is switched off in fault mode.
→ The fault mode can be cancelled by switching off and on again. **Do not repeat more than twice!**
- If the heater is overheated (lack of water, poorly vented cooling circuit), the overheating sensor triggers, the fuel supply is interrupted and the heater is switched off in fault mode.
Once the cause of overheating has been eliminated, *HYDRONIC* can be switched on again by switching off and on again (on condition that *HYDRONIC* has cooled down sufficiently, cooling water temperature < 70°C). The controller is locked after a certain number of overheating shut-downs*.
- The heater is switched off in fault mode if the lower or upper voltage limit is reached.
- *HYDRONIC* does not start when the glow plug is defect or electrical lead to the dosing pump is interrupted.
- The fan motor speed is monitored continuously. If the fan motor does not start up, is blocked or if the speed falls below 40% of the nominal speed, the heater is switched off in fault mode after 60 secs.

* Faults or cancellation of the locked status:

- with the module clock
- with the remote control TP5.

Using other controls when the following are connected:

- diagnosis unit
- customer service program KD 2000 (see pages 16 to 21).

Please note

- The coolant must contain min. 10% anti-freeze all year-round as corrosion protection.
- The plus cable of the battery must be disconnected and placed on ground to protect the controller during electric welding on the vehicle.



3 Technical data

Technical data – HYDRONIC

Heater		B 5 W S		D 5 W S	
Heating medium		Water, coolant			
Control of heat flow		large	small	large	small
Heat flow (watt)		5000	1500	5000	2400
Fuel consumption (l/h)		0.69	0.20	0.62	0.27
Mean electr. power consumption (watt)	in operation	37	10	37	10
	at start	110			
	after-running	8			
Rated voltage		12 volt		12 volt	24 volt
Operating range Lower voltage limit An undervoltage protection device in the controller switches the heaters off at approx. 10 / 20 volt		10.2 volt		10.2 volt	20.4 volt
Upper voltage limit An overvoltage protection device in the controller switches the heaters off at approx. 16 / 32 volt		16 volt		16 volt	32 volt
Tolerable operating pressure		up to 2.5 bar overpressure			
Minimum water flow through the heater		250 l/h			
Fuel "fuel quality and fuel at low temperatures" (see operating instructions)		petrol – commercially available (DIN 51600 and DIN EN 228)		diesel – commercially available (DIN EN 590) PME (DIN V 51606) only at D 5 W S, 24 volt	
Tolerable ambient temperature		operation – HYDRONIC		–40 °C to +80 °C	
		operation – dosing pump		–40 °C to +20 °C	
		storage – HYDRONIC / dosing pump		–40 °C to +105 °C	
Degree of interference suppression		2 for LW 5 for FM / KW / MW			
Weight without water and add on pieces with water pump and dosing pump		approx. 2.3 kg approx. 2.9 kg			

All technical data ±10 %



Caution

The stated technical data must be complied to prevent malfunctions of HYDRONIC.

3 Technical data

Technical data – water pump

Rated voltage	12 volt	24 volt
Operating voltage	9 volt to 15 volt	18 volt to 32 volt
Electrical power consumption	16 watt	12 watt
Pumping capacity	820 l/h	
Pumping pressure	0.1 bar	
Operating temperature	-40 °C to +135 °C	
Weight	0.28 kg	

All technical data $\pm 10\%$



Caution

The stated technical data must be complied to prevent malfunctions of *HYDRONIC*.

Pump curve

Water pump – 12 volt

Order no. 25 2217 25 00 00

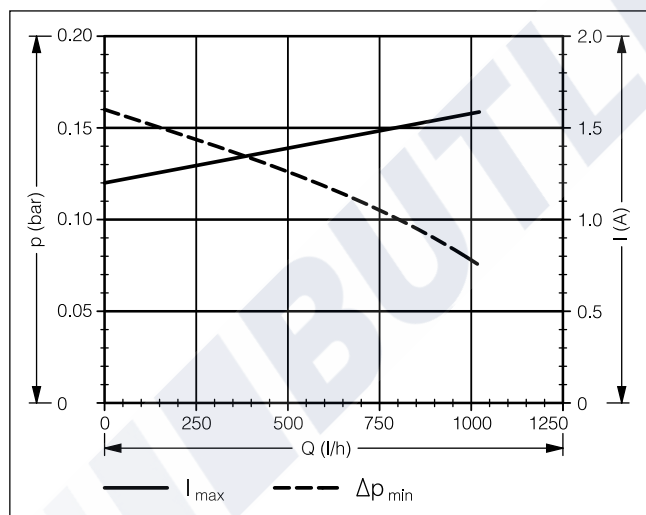

Pump curve

Water pump – 24 volt

Order no. 25 2218 25 00 00

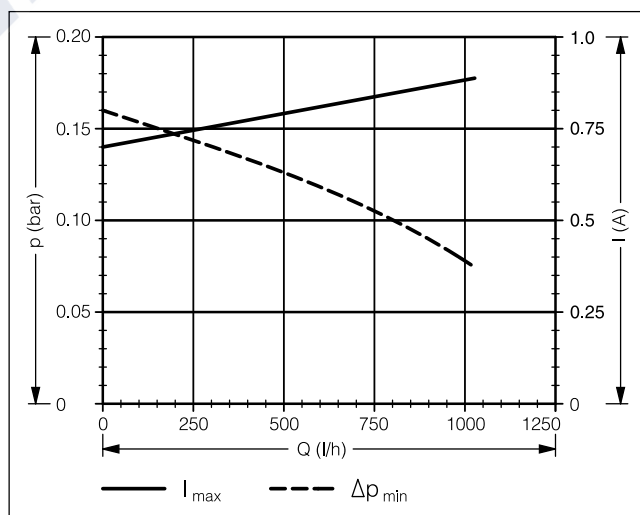



4 Troubleshooting

When faults occur, first check ...

- Faulty wiring?
(short circuits, interruptions)
- Visual check for
 - corroded contacts
 - defect fuses
 - damaged electrical leads, links and connections
 - damaged exhaust and combustion air guidance
- Check battery voltage
 - Battery voltage < 10 volt: the undervoltage protection has triggered in *HYDRONIC* – 12 volt.
 - Battery voltage < 20 volt: the undervoltage protection has triggered in *HYDRONIC* – 24 volt.
- Check fuel supply
- When changing over to winter operations:
Is there still summer diesel in the pipes?
- **Check voltage supply U_{batt} (terminal 30)**
Disconnect the 8-pole connection S1 / B1 and measure the voltage present in connector B1 between chamber 1 (cable 2.5² red) and chamber 2 (cable 2.5² brown). For deviations in the battery voltage, check the fuses, supply lines, ground connection and plus point on battery for loss of voltage (corrosion / interruption).
- **Check switch-on signal (S+)**
Disconnect the 8-pole connector S1 / B1 and then press button  on the controls.
Measure the voltage present in connector 1 between chamber 7 (cable 0.5² yellow) and chamber 2 (cable 2.5² brown). If there is no voltage, then check the power supply line (cable 0.5² yellow), the fuse 5A (item 2.7.1 in wiring diagram) and the controls.
- **Check controls (module timer / mini timer)**
Disconnect the connector from the controls and bridge cable 0.5² red and cable 0.5² yellow.
If there is voltage in connector B1 between chamber 7 (cable 0.5² yellow) and chamber 2 (cable 2.5² brown), then replace the controls.

Controller lock

The controller is locked when the following faults occur:

- **Overheating**
If *HYDRONIC* overheats 10 times in succession, error code 015 appears à the controller is locked.
- **Too many start attempts**
If *HYDRONIC* performs 10 start attempts in vain, error code 050 appears à the controller is locked.

Cancel the controller lock

Cancelling the controller lock depends on the corresponding testing equipment and is described on pages 16 to 21.

Testing equipment

The following testing equipment can be used to query the fault memory in the controller and if necessary, to cancel the controller lock:

Testing equipment	Order number
• Diagnosis instrument (available until 12.2001) also necessary: adapter cable	22 1512 89 00 00 22 1000 30 71 00
• Diagnosis instrument (available as from 04.2002) also necessary: adapter cable	22 1529 89 00 00 22 1000 31 63 00
• Customer service program KD 2000 also necessary: adapter cable	22 1524 89 00 00 22 1000 31 63 00

If the diagnosis lead is connected up, the following controls can also be used:

• Module clock	22 1000 30 34 00
• Radio remote control TP5	22 1000 32 01 00

4 Troubleshooting

Testing equipment

The electronic controller of *HYDRONIC* can save up to 5 errors. The errors can be read and displayed from the controller using one of the following items of equipment. In addition, the controller lock can be cancelled.

- **Diagnosis instrument**

After connecting the diagnosis instrument, the function or error is shown numerically in the display. For connection and handling of the diagnosis instrument, see page 17 and 18. An adapter cable is necessary to connect up the diagnosis instrument.

Error code table see page 22 to 26.

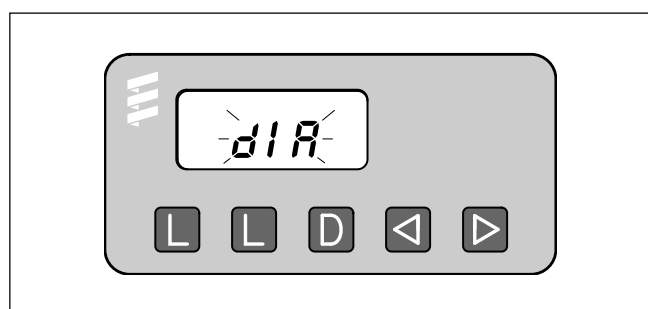

Order no.

Diagnosis instrument 22 1529 89 00 00

Adapter cable 22 1000 31 63 00

- **Module clock – installed in the vehicle**

The integrated module clock can be used to show the function or error numerically in the display.

Handling the module clock see page 19.

Error code table see page 22 to 26.

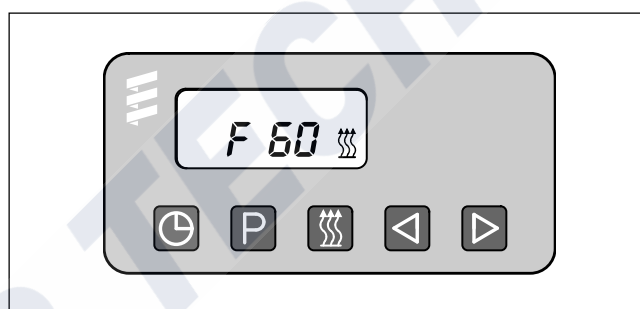

Order no.

Module clock

22 1000 30 34 00

- **Customer service program KD 2000**

After installation of the customer service program KD 2000 and connection of the ISO adapter, the function or error is shown numerically on the monitor. For connection and handling of the ISO adapter, see page 20.

An adapter cable is necessary to connect up the ISO adapter.

Error code table see page 22 to 26.

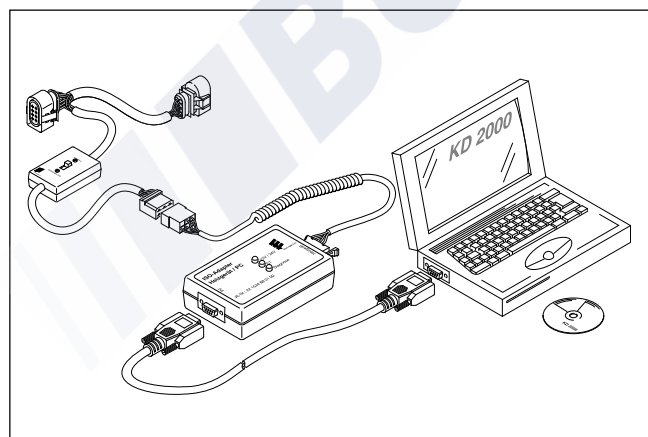

Order no.

ISO adapter 22 1524 89 00 00

Adapter cable 22 1000 31 63 00

- **Radio remote control TP5**

The radio remote control TP5 can be used to show the function or error numerically in the display.

Handling of the radio remote control TP5 see page 21.

Error code table see page 22 to 26.



Order no.

Radio remote control TP5 22 1000 32 01 00



4 Troubleshooting

Fault diagnosis with the diagnosis instrument

Diagnosis instrument
Order no. 22 1529 89 00 00

An adapter cable is necessary to connect up the diagnosis instrument

Adapter cable
Order no. 22 1000 31 63 00

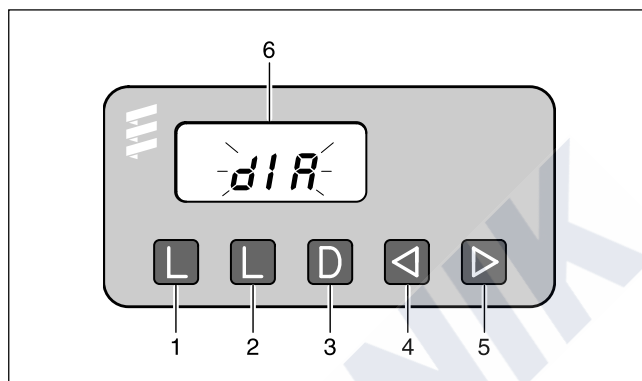

- ① Button –delete fault memory
- ② Button –delete fault memory
- ③ Button –switch heater on / off request diagnosis
- ④ Button –backwards, fault F5 – F1, AF
- ⑤ Button –forwards, fault AF, F1 – F5
- ⑥ Display

The electronic controller of *HYDRONIC* can save up to 5 faults, which can be read and displayed with the diagnosis instrument.

The current fault is shown as “AF” and a 2-digit number and always written in memory place F1. Previous faults are transferred to memory places F2 to F5, and the contents of memory place F5 are overwritten.

Connecting up the diagnosis instrument

- Disconnect the 8-pole connector from the *HYDRONIC* cable harness and connect the adapter cable.
- Then connect the diagnosis instrument to the adapter cable.

The display shows:

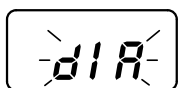

Querying the fault memory

- Press the button on the diagnosis unit to switch on *HYDRONIC*.

The display shows:



- After 8 secs, the display shows:



no error

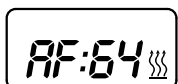

current fault (e.g. error code 64)

Error code, fault description, cause and remedies are described on pages 22 to 26.



Fault diagnosis not possible

Possible causes:

- adapter cable not connected properly
- controller defect or not capable of diagnosis (not a universal controller).

Display of fault memory F1 – F5 or F5 – F1

- Press the buttons or once or several times to show the individual fault memories in decreasing or increasing order. The display shows:

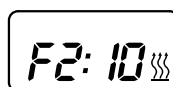

e.g. fault memory 2 / error code 10

Only those fault memories occupied by a fault are shown.

Delete fault memory

- Eliminate cause of fault.
- Press both buttons at the same time until the display shows:

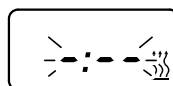

- Once the fault memories are deleted, the last current fault is shown. The current fault is not reset to 00 until the next restart of *HYDRONIC*, insofar as no other current fault has occurred. The display shows:

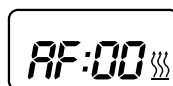

HYDRONIC no faults

4 Troubleshooting

Controller lock

- Overheating:
If *HYDRONIC* overheats 10 times in succession, fault 012, AF 015 appears in the display, i.e. the controller is locked.
- Too many start attempts:
If *HYDRONIC* performs 10 start attempts in vain, fault 052, AF 050 appears in the display, i.e. the controller is locked.

Cancelling the controller lock

- Delete the fault memory as described and switch off *HYDRONIC* with button **D**.
- The controller lock is cancelled and the diagnosis finished.
The display shows:

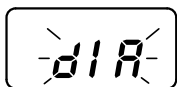

Please note

Not only a defect component but also a defect current path results in a display.

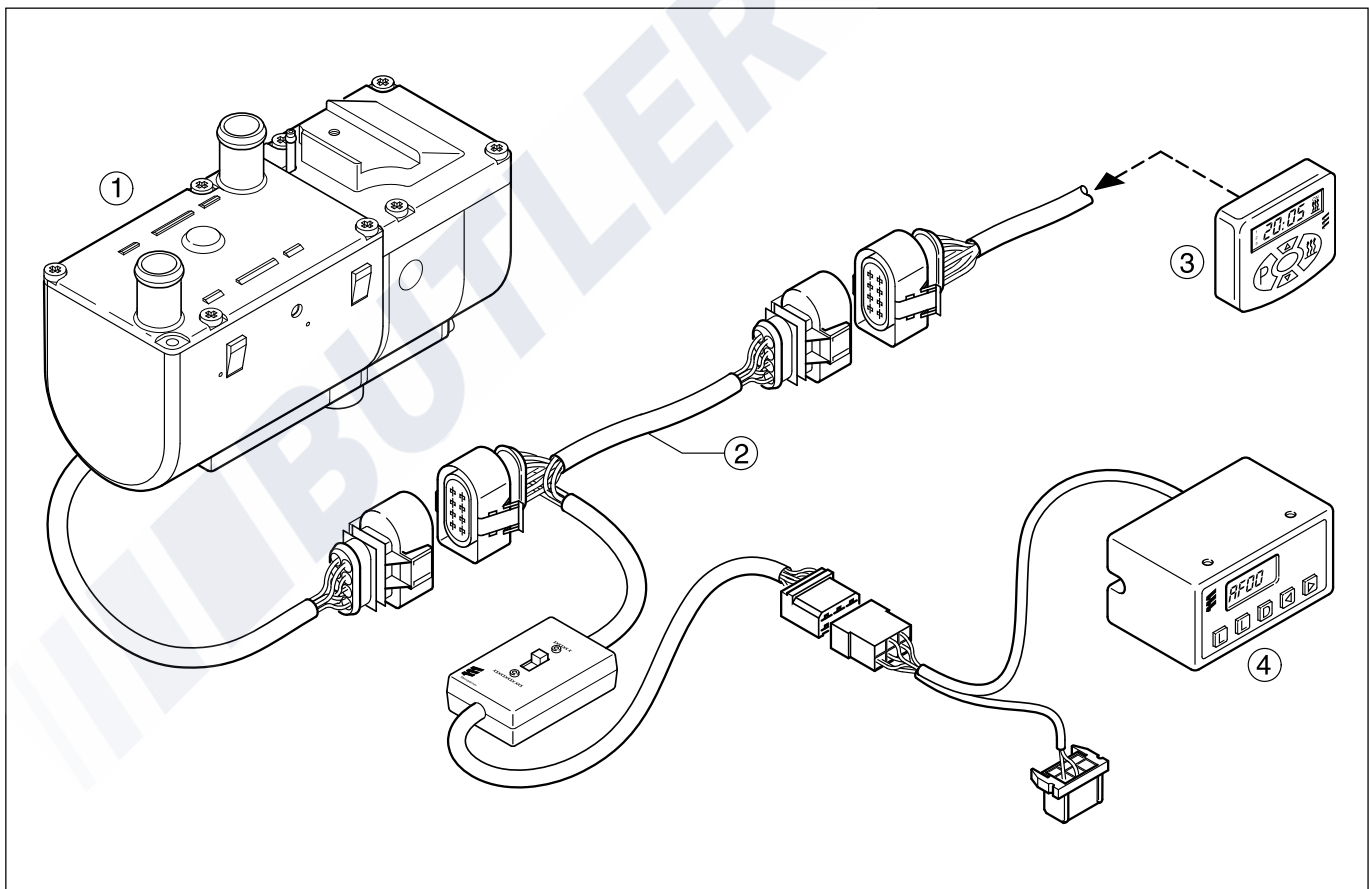

- ① *HYDRONIC*
- ② Adapter cable
- ③ Mini timer
- ④ Diagnosis instrument



4 Troubleshooting

Fault diagnosis with the module clock

Module clock

Order no. 22 1000 30 34 00

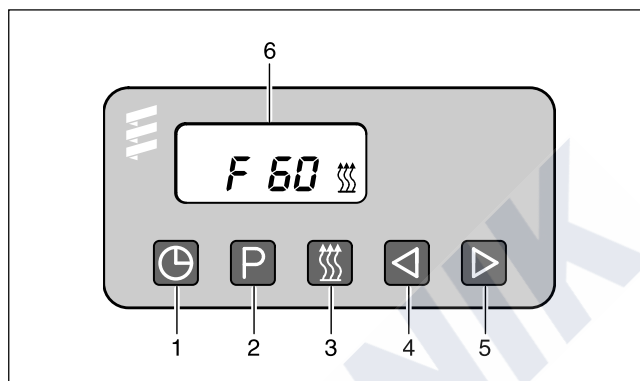

- ① Button – time
- ② Button – preselection
- ③ Button – heating
- ④ Button – backwards
- ⑤ Button – forwards
- ⑥ Display showing the faults

The electronic controller can save up to 5 faults, which can be read and displayed with the module clock.

The current fault is shown as “AF” and is always written in memory place F1.

Previous faults are transferred to memory places F2 to F5, and the contents of memory place F5 are overwritten.

Query fault memory F1 to F5

Condition:

HYDRONIC is switched off.

- Press button --> *HYDRONIC* is switched on.
- Press button and hold pressed, then press button within 2 seconds.
The display shows:
AF = current fault
3 digit number = error code
 flashes.
- Press button once or several times, fault memories F1 to F5 are shown.

Please note

Error code, fault description, cause / remedies are described on pages 22 to 26.

Cancel the controller lock and at the same time delete the fault memory

Condition:

There is an electrical connection from terminal 15 (ignition) to the module clock, 12-pole connector, chamber 10.

- Press button
The display shows:
current fault F15 or F50.
- Press button , hold pressed and press button within 2 seconds.

The module clock is now in the program “query fault memory”.
- Switch off the ignition (terminal 15).
- Press button and button at the same time, also switch the ignition on (terminal 15) and wait until the following is shown in the display.

After ignition “ON”, the display shows:

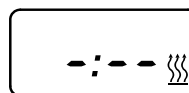

Display flashes
Heating symbol does not flash

- Switch *HYDRONIC* off and on --> the controller is unlocked, *HYDRONIC* starts again.

After switching off and on and after querying the fault memory again, the display shows:



Display flashes
Heating symbol does not flash

4 Troubleshooting

Fault diagnosis with customer service program KD 2000

Customer service program KD 2000
Order no. 22 1524 89 00 00

An adapter cable is required to connect the ISO adapter.
Order no. 22 1000 31 63 00

The electronic controller can save up to 5 faults.
The faults can be read and displayed with the ISO adapter and the KD 2000 software.

Connect the ISO adapter

- Disconnect the *HYDRONIC* cable harness.
- Connect the adapter cable into the cable harness as shown in the drawing.
- Connect the adapter cable to the ISO adapter.
- Connect the SUB-D connection cable with the PC and the ISO adapter.

Please note

It is vitally important to comply with the order of installation.

Install KD 2000 software on the computer

- Place the CD-ROM in the CD drive
- Do a double click to run the file "setup.exe" and follow the instructions of the SETUP program.

Query fault memory F1 – F5 / delete fault memory / cancel controller lock

- Run KD 2000 software on the computer:
 - On the desktop, do a double click on the "KD 2000" icon
 - Select the heater type
 - Press "GO".
- Delete fault memory respectively cancel controller lock:
 - Press button "delete fault memory"
 - > the saved faults F1 to F5 are deleted and the controller is unlocked.

Finish diagnosis

- Press button "STOP" --> this finishes the fault memory query.

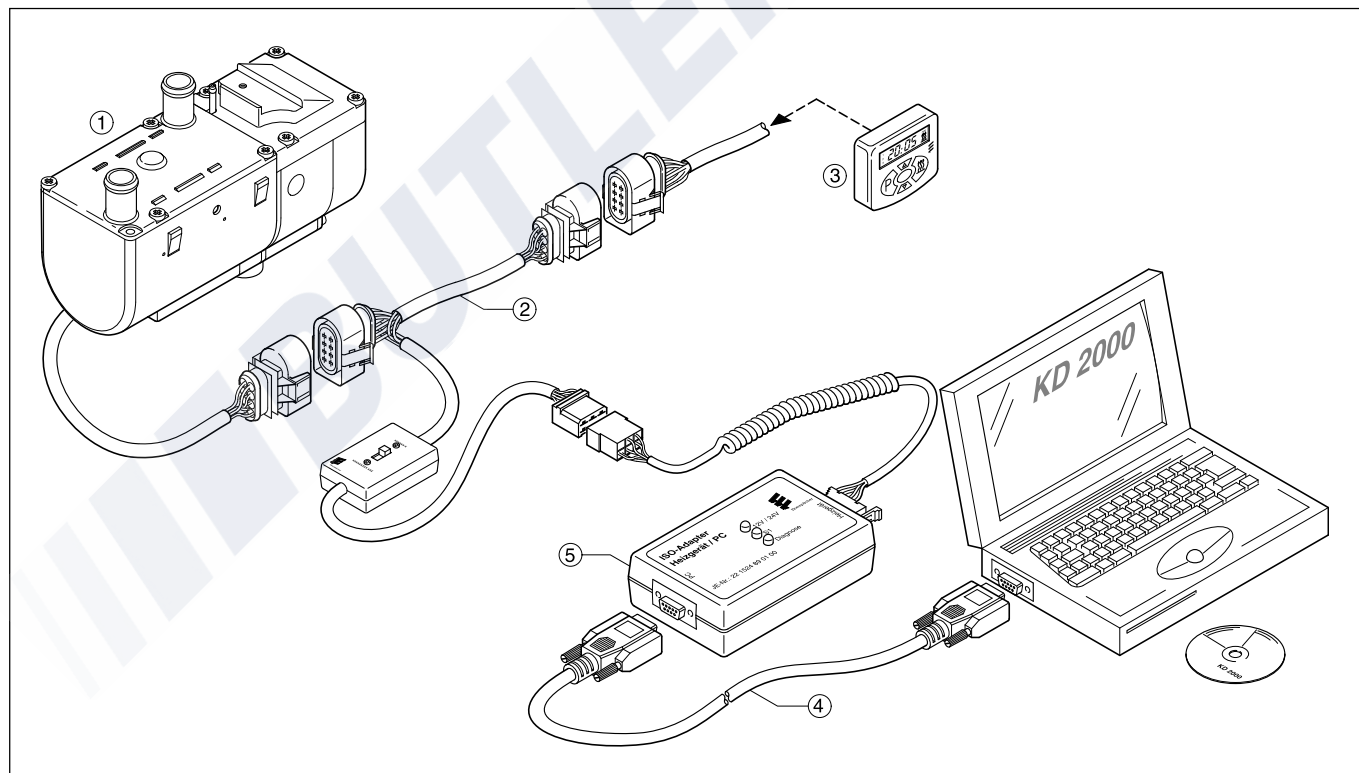

- ① *HYDRONIC*
- ② Adapter cable
- ③ Mini timer
- ④ SUB-D connection cable
- ⑤ ISO adapter



4 Troubleshooting

Fault diagnosis with radio remote control TP5

Radio remote control TP5
Order no. 22 1000 32 01 00

- Button to activate / deactivate the remote control
- Button to move time setting forwards
- Button to move time setting backwards
- Button to activate adjustment possibilities
- Button for ON / OFF for heating / venting; activate / deactivate preselection time



If errors occur in the heater during operation, once the remote control has been activated these are shown with "Err".

Please note

Prerequisite for performing the diagnosis is that the diagnosis lead (blue / white) is connected to the stationary part and to the heater cable harness, complying with the circuit diagram for the radio remote control TP5 and the heater.

Note:

The "diagnosis" menu is blocked when the diagnosis lead (blue / white) is not connected.
Once the diagnosis lead (blue / white) has been connected

and the first protocols have arrived at the stationary set, the diagnosis can be performed with the radio remote control TP5. The current fault "F0" is shown. The saved faults "F1" to "F5" can be queried.

The error is to be eliminated according to the troubleshooting and repair instructions of the heater.

Example:

- „F0 --“ = error-free operation
- „F011“ = current fault 11
- „F110“ = fault 10 saved in fault memory 1 ("F1").

Error code, fault description, cause and remedies are described on pages 22 to 26.

Query / delete fault memory

Press button to activate the remote control.
Switch the heater on with button .

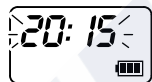

Press button twice to go to the time adjusting menu – the time flashes in the display.



- Press button .
- Press button .
- Press button 2 x.
- Press button .

Heater with error:



Heater without error:

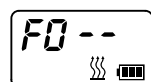

Use buttons and to go to fault memories 1 to 5.



Delete fault memory / cancel controller lock

Press button to delete the fault memory.

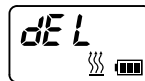

Press button for approx. 2 secs. to confirm until lights up in the display: fault memory is deleted.



Please note



If the fault memory is deleted at a later point in time, the whole procedure has to be repeated.

4 Troubleshooting

Error code Display	Fault description	Explanations • Remedies
010	Overvoltage – shutdown	<p>Overvoltage at controller min. 20 seconds without interruption --> <i>HYDRONIC</i> does not function.</p> <ul style="list-style-type: none"> • Disconnect connection B1/S1, start vehicle engine, measure voltage in connector B1 between chamber 1 (cable 2.5² red) and chamber 2 (cable 2.5² brown). If the voltage > 15 / 32 volt, then check the dynamo regulator or battery.
011	Undervoltage – shutdown	<p>Undervoltage at controller min. 20 seconds without interruption --> <i>HYDRONIC</i> does not function.</p> <ul style="list-style-type: none"> • Disconnect connection B1/S1, vehicle engine is off, measure voltage in connector B1 between chamber 1 (cable 2.5² red) and chamber 2 (cable 2.5² brown). If voltage < 10 / 20 volt, then check fuses, supply lines, ground connections and plus points on battery for loss of voltage (corrosion).
012	Overheating (software – threshold value)	<p>Temperature at overheating sensor > 125°C.</p> <ul style="list-style-type: none"> • Check water circuit; <ul style="list-style-type: none"> – Check all hoses for any leaks – Is there a throttle in the water circuit? – Has the direction of flow been observed when installing thermostat and non-return valve? – Is the water circuit properly vented? – Check functions of water pump • Check temperature sensor and overheating sensor, replace if necessary – control values see page 36.
014	Possible overheating detected (differential evaluation)	<p>Difference in temperature values of overheating sensor and temperature sensor > 25 K. Prerequisite for this error code is that <i>HYDRONIC</i> is operating and the water temperature at the overheating sensor has reached min. 80°C.</p> <ul style="list-style-type: none"> • Check water circuit: <ul style="list-style-type: none"> – Check all hoses for any leaks – Is there a throttle in the water circuit? – Has the direction of flow been observed when installing thermostat and non-return valve? – Is the water circuit properly vented? – Check functions of water pump • Check temperature sensor and overheating sensor, replace if necessary – control values see page 36.
015	Operation lock – heater has overheated more than 10 times	<p>Controller is locked</p> <ul style="list-style-type: none"> • Unlock controller by deleting fault memory (see page 17 to 20). • Check water circuit <ul style="list-style-type: none"> – Check all hoses for any leaks – Is there a throttle in the water circuit? – Has the direction of flow been observed when installing thermostat and non-return valve? – Is the water circuit properly vented? – Check functions of water pump.



4 Troubleshooting

Error code Display	Fault description	Explanations • Remedies
017	Overheating detected – EMERGENCY OFF (hardware limit value)	Temperature at overheating sensor > 130°C. <ul style="list-style-type: none"> • Check water circuit: <ul style="list-style-type: none"> – Check all hoses for any leaks. – Is there a throttle in the water circuit? – Has the direction of flow been observed when installing thermostat and non-return valve? – Is the water circuit properly vented? – Check functions of water pump. • Check temperature sensor and overheating sensor, replace if necessary – control values see page 36.
020	Glow plug – interruption	<ul style="list-style-type: none"> • Perform function test of glow plug in installed condition. To do so, unclip cable 1.5² white from chamber 9 of the 14-pole connector and cable 1.5² brown from chamber 12. Apply voltage of 8 / 18 V ± 0.1 V to the glow plug and measure current after 25 sec. The glow plug is OK with the following values; if the values differ, replace the glow plug. Glow plug 8 volt – current = 8.5 A ^{+1A} _{-1,5A} • If glow plus is OK, check glow plug lead for any signs of damage, check for current passage.
021	Glow plug output: short circuit, overload or accidental ground  Caution In <i>HYDRONIC</i> 12 volt, perform the function test with max. 8 volt. In <i>HYDRONIC</i> 24 volt, perform the function test with max. 18 volt. Glow plug destroyed if voltage values exceeded. → Ensure mains adapter is short-circuit proof.	
030	Speed of combustion fan motor outside tolerance range.  Caution In <i>HYDRONIC</i> 12 volt, perform the function test with max. 8.2 volt + 0.2 volt. In <i>HYDRONIC</i> 24 volt, perform the function test with max. 15 volt + 0.2 volt. Check that plus an minus leads are connected correctly. → Ensure mains adapter is short-circuit proof.	Fan impeller of combustion air fan motor blocked (frozen, dirty, stiff, lead chafes at end of shaft ...). <ul style="list-style-type: none"> • Remove blockage. • Measure speed of combustion air fan motor with max. 8.2 / 15 volt + 0.2 volt. To do so, unclip cable 0.75² brown from chamber 14 of 14-pole connector and cable 0.75² black from chamber 13. Affix a marking to the shaft end of the combustion air fan motor and measure the speed with a contact-free speed counter (see page 33). If the measured speed < 10000 rpm, then replace the combustion air fan. If the measured speed > 10000 rpm, then replace the controller.
031	Combustion air motor – interruption  Caution In <i>HYDRONIC</i> 12 volt, perform the function test with max. 8.2 volt + 0.2 volt. In <i>HYDRONIC</i> 24 volt, perform the function test with max. 15 volt + 0.2 volt. Check that plus an minus leads are connected correctly. → Ensure mains adapter is short-circuit proof.	<ul style="list-style-type: none"> • Check that the cable harness of the combustion air fan motor is properly routed and check for any signs of damage. • Measure speed of combustion air fan motor with max. 8.2 / 15 volt + 0.2 volt. To do so, unclip cable 0.75² brown from chamber 14 of 14-pole connector and cable 0.75² black from chamber 13. Affix a marking to the shaft end of the combustion air fan motor and measure the speed with a contact-free speed counter (see page 33). If the measured speed < 10000 rpm, then replace the combustion air fan. If the measured speed > 10000 rpm, then replace the controller.

4 Troubleshooting

Error code Display	Fault description	Explanations • Remedies
032	<p>Combustion air motor – short circuit, overload or accidental ground</p>  <p>Caution In <i>HYDRONIC</i> 12 volt, perform the function test with max. 8.2 volt + 0.2 volt. In <i>HYDRONIC</i> 24 volt, perform the function test with max. 15 volt + 0.2 volt. Check that plus an minus leads are connected correctly. → Ensure mains adapter is short-circuit proof.</p>	<p>Fan impeller of combustion air fan motor blocked (frozen, dirty, stiff, lead chafes at end of shaft ...).</p> <ul style="list-style-type: none"> • Remove blockage. • Before checking the functions of the combustion air fan motor, perform a resistance measurement between housing and lead. If the measured resistance < 2 kΩ then there is accidental ground. Replace the combustion air fan. If the measured value is > 2 kΩ, then measure the speed of the combustion air fan motor. • Measure speed of combustion air fan motor with max. 8.2/ 15 volt + 0.2 volt. To do so, unclip cable 0.75² brown from chamber 14 of 14-pole connector and cable 0.75² black from chamber 13. Affix a marking to the shaft end of the combustion air fan motor and measure the speed with a contact-free speed counter (see page 33). If the measured speed < 10000 rpm, then replace the combustion air fan. If the measured speed > 10000 rpm, then replace the controller.
038	<p>Relay trigger of vehicle fan – interruption</p> <div style="border: 1px solid black; padding: 2px; width: fit-content;"> <p>Please note</p> </div> <p>This fault code is not displayed by all types of heaters.</p>	<ul style="list-style-type: none"> • Check electric lead to relay, rectify interruption, replace relay if necessary.
039	<p>Relay trigger of vehicle fan – short circuit, overload or accidental ground</p>	<ul style="list-style-type: none"> • Pull relay off; if error code 038 is then shown, the relay is defect – replace relay.
041	<p>Water pump – interruption</p>	<ul style="list-style-type: none"> • Check lead to water pump for current passage. To do so, unclip cable 0.5² brown from chamber 10 of 14-pole connector and cable 0.5² from cable 11. Rectify interruption, replace water pump if necessary.
042	<p>Water pump – short circuit, overload or accidental ground</p>	<ul style="list-style-type: none"> • Disconnect connection in water pump cable harness. If error code 041 is then shown, the water pump is defect – replace water pump.
047	<p>Dosing pump – short circuit, overload or accidental ground</p>	<ul style="list-style-type: none"> • Disconnect connection in dosing pump cable harness. If error code 048 is then shown, the dosing pump is defect – replace dosing pump.
048	<p>Dosing pump – interruption</p>	<ul style="list-style-type: none"> • Check dosing pump cable harness for current passage. Rectify interruption, replace dosing pump if necessary.
050	<p>Operation lock because of too many failed starting attempts (10 starting attempts, also start repetition for every starting attempt)</p>	<p>Too many starting attempts, controller locked.</p> <ul style="list-style-type: none"> • Unlock controller by deleting fault memory (see page 17 to 20). • Check fuel quantity and fuel supply, see page 37.



4 Troubleshooting

Error code Display	Fault description	Explanations • Remedies
051	Time exceeded – blowing cold	At start, flame sensor reports temperature > 70°C for longer than 240°C. <ul style="list-style-type: none"> • Check exhaust and combustion air guidance. • Check flame sensor – control values see page 32.
052	Safety time exceeded	<ul style="list-style-type: none"> • Check exhaust and combustion air guidance. • Check fuel quantity and fuel supply, see page 37. • Clean or replace filter in dosing pump connection.
053 056	Flame aborted from control stage “large” Flame aborted from control stage “small”	<p>Warning After flame aborted from control stage “large” or “small” and after starting attempt within allowed number, <i>HYDRONIC</i> proceeds with a new start, where applicable with subsequent start repeat. If the new start or start repeat is successful, the error code is deleted.</p> <p>Error (because no more starting attempts allowed)</p> <ul style="list-style-type: none"> • Check exhaust and combustion air guidance. • Check fuel quantity and fuel supply, see page 37. • Check flame sensor, see error code 064 and 065.
060	Temperature sensor – interruption <div style="border: 1px solid black; padding: 2px; width: fit-content;">Please note</div> The test with a bridge in the 14-pole connector can only be performed if <i>HYDRONIC</i> is still installed in the vehicle or if a test facility is available.	<ul style="list-style-type: none"> • Remove controller and check connection lead of temperature sensor for any signs of damage. If the lead is OK, then short the temperature sensor: route the cable in the 14-pole connector from chamber 3 to chamber 4. Switch <i>HYDRONIC</i> on: <ul style="list-style-type: none"> – If error code 061 appears, then remove and check temperature sensor, see page 36. – If error code 060 still appears, then check and if necessary replace controller.
061	Temperature sensor – short-circuit, overload or accidental ground <div style="border: 1px solid black; padding: 2px; width: fit-content;">Please note</div> The test with a bridge in the 14-pole connector can only be performed if <i>HYDRONIC</i> is still installed in the vehicle or if a test facility is available.	<ul style="list-style-type: none"> • Remove controller and check connection lead of temperature sensor for any signs of damage. If the lead is OK, then remove the 14-pole connector from controller, unclip cable 0.5² blue from chamber 3 and cable 0.5² blue from chamber 4. Connect 14-pole connector to controller and switch <i>HYDRONIC</i> on. <ul style="list-style-type: none"> – If error code 061 appears, then remove and check temperature sensor, see page 36. – If error code 061 appears, then check and if necessary replace controller. • Remove controller and check connection lead of flame sensor for any signs of damage. If the lead is OK, then short the flame sensor: route the cable in the 14-pole connector from chamber 1 to chamber 2. Switch <i>HYDRONIC</i> on: <ul style="list-style-type: none"> – If error code 065 appears, then remove and check flame sensor, see page 34. – If error code 064 still appears, then check and if necessary replace controller.
064	Flame sensor – interruption <div style="border: 1px solid black; padding: 2px; width: fit-content;">Please note</div> The test with a bridge in the 14-pole connector can only be performed if <i>HYDRONIC</i> is still installed in the vehicle or if a test facility is available.	<ul style="list-style-type: none"> • Remove controller and check connection lead of flame sensor for any signs of damage. If the lead is OK, then short the flame sensor: route the cable in the 14-pole connector from chamber 1 to chamber 2. Switch <i>HYDRONIC</i> on: <ul style="list-style-type: none"> – If error code 065 appears, then remove and check flame sensor, see page 34. – If error code 064 still appears, then check and if necessary replace controller.

4 Troubleshooting

Error code Display	Fault description	Explanations • Remedies
065	<p>Flame sensor – short-circuit, overload or accidental ground</p> <p>Please note The test with a bridge in the 14-pole connector can only be performed if <i>HYDRONIC</i> is still installed in the vehicle or if a test facility is available.</p>	<ul style="list-style-type: none"> Remove controller and check connection lead of flame sensor for any signs of damage. If the lead is OK, then remove the 14-pole connector from controller, unclip cable 0.5² blue from chamber 1 and cable 0.5² brown from chamber 2. Connect 14-pole connector to controller and switch <i>HYDRONIC</i> on. <ul style="list-style-type: none"> If error code 064 appears, then remove and check flame sensor, see page 32. If error code 065 appears, then check and if necessary replace controller.
071	<p>Overheating sensor – interruption</p> <p>Please note The test with a bridge in the 14-pole connector can only be performed if <i>HYDRONIC</i> is still installed in the vehicle or if a test facility is available.</p>	<ul style="list-style-type: none"> Remove controller and check connection lead of overheating sensor for any signs of damage. If the lead is OK, then short the overheating sensor: route the cable in the 14-pole connector from chamber 5 to chamber 6. Switch <i>HYDRONIC</i> on: <ul style="list-style-type: none"> If error code 072 appears, then remove and check overheating sensor, see page 36. If error code 071 still appears, then check and if necessary replace controller.
072	<p>Overheating sensor – short-circuit, overload or accidental ground</p> <p>Please note The test with a bridge in the 14-pole connector can only be performed if <i>HYDRONIC</i> is still installed in the vehicle or if a test facility is available.</p>	<ul style="list-style-type: none"> Remove controller and check connection lead of overheating sensor for any signs of damage. If the lead is OK, then remove the 14-pole connector from controller, unclip cable 0.5² red from chamber 5 and cable 0.5² red from chamber 6. Connect 14-pole connector to controller and switch <i>HYDRONIC</i> on. <ul style="list-style-type: none"> If error code 071 appears, then remove and check overheating sensor, see page 36. If error code 072 appears, then check and if necessary replace controller.
090 092–103	Controller defect	Replace controller.
091	External interference voltage	Error in controller from interference voltage from vehicle network, possible causes: poor batteries, poor battery chargers, other interference sources; eliminate interference voltages.

Faults not shown by the diagnosis system

Fault description

HYDRONIC won't start

Explanations • Remedies

After switching *HYDRONIC* on, the water pump and vehicle fan start immediately.

- Remove and check temperature sensor, see page 36.

After switching *HYDRONIC* on, the vehicle fan starts, function "pre-venting" is activated.

- Changeover venting to heating at "heating / venting" changeover switch.



5 Repair instructions

Repair instructions

The chapter “repair instructions” describes the repair and servicing work allowed at *HYDRONIC*. These repair instructions look in detail at the petrol respectively diesel version where the repair steps differ. It is recommended to remove *HYDRONIC* from the vehicle for extensive repair work.

HYDRONIC is always re-assembled in the reverse order; note additional instructions where given.

Please note

A function test must always be performed after completing all work on *HYDRONIC* (see page 5).

Before working on *HYDRONIC*, please comply with the following safety instructions:



Danger!

Risk of injury, burning and poisoning!

- Always switch *HYDRONIC* off beforehand and allow to cool down.
- Disconnect the battery.
- Release overpressure in the cooling system by opening the radiator cap.
- *HYDRONIC* may not be operated in closed rooms such as garages or workshops.
Exception:
when there is a device to extract the exhaust directly from the opening of the exhaust pipe.

Please note

- Seals from removed parts must be replaced.
- During repair work, check all parts for any signs of damage and replace where necessary.
- Check connector contacts, connections and leads for corrosion and any signs of damage, and repair where necessary.
- If spares are needed, only original Eberspächer spare parts may be used.
- After working on the coolant circuit, check the level of coolant. If necessary, top up with coolant according to the instructions issued by the vehicle manufacturer. Then vent the coolant circuit.
- Operation or after-running of *HYDRONIC* may only be stopped in an emergency (see EMERGENCY STOP page 7) by interrupting the current from the battery (risk of *HYDRONIC* overheating).

AMP unlocking tool

The AMP unlocking tool is used for detaching receptacles from a connector housing.

This unlocking tool can be ordered direct from Eberspächer GmbH & Co. KG,

- Micro-Timer order no. 206 00 205
- Junior-Power-Timer order no. 206 00 204



AMP unlocking tool, order no. 72 65 34-1

Fitting *HYDRONIC* back in the vehicle again

When fitting *HYDRONIC* back into the vehicle again, the fastening screw M6 x 100 must be replaced, order no. 100 10 037.

Torque: 6^{+0.5} Nm.

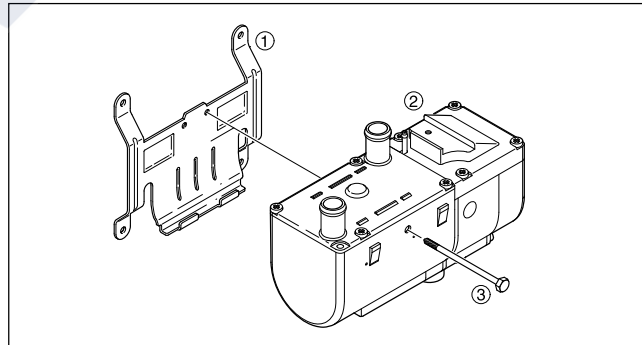

- ① Heater bracket
- ② *HYDRONIC*
- ③ Fastening screw

5 Repair instructions

Assembly drawing

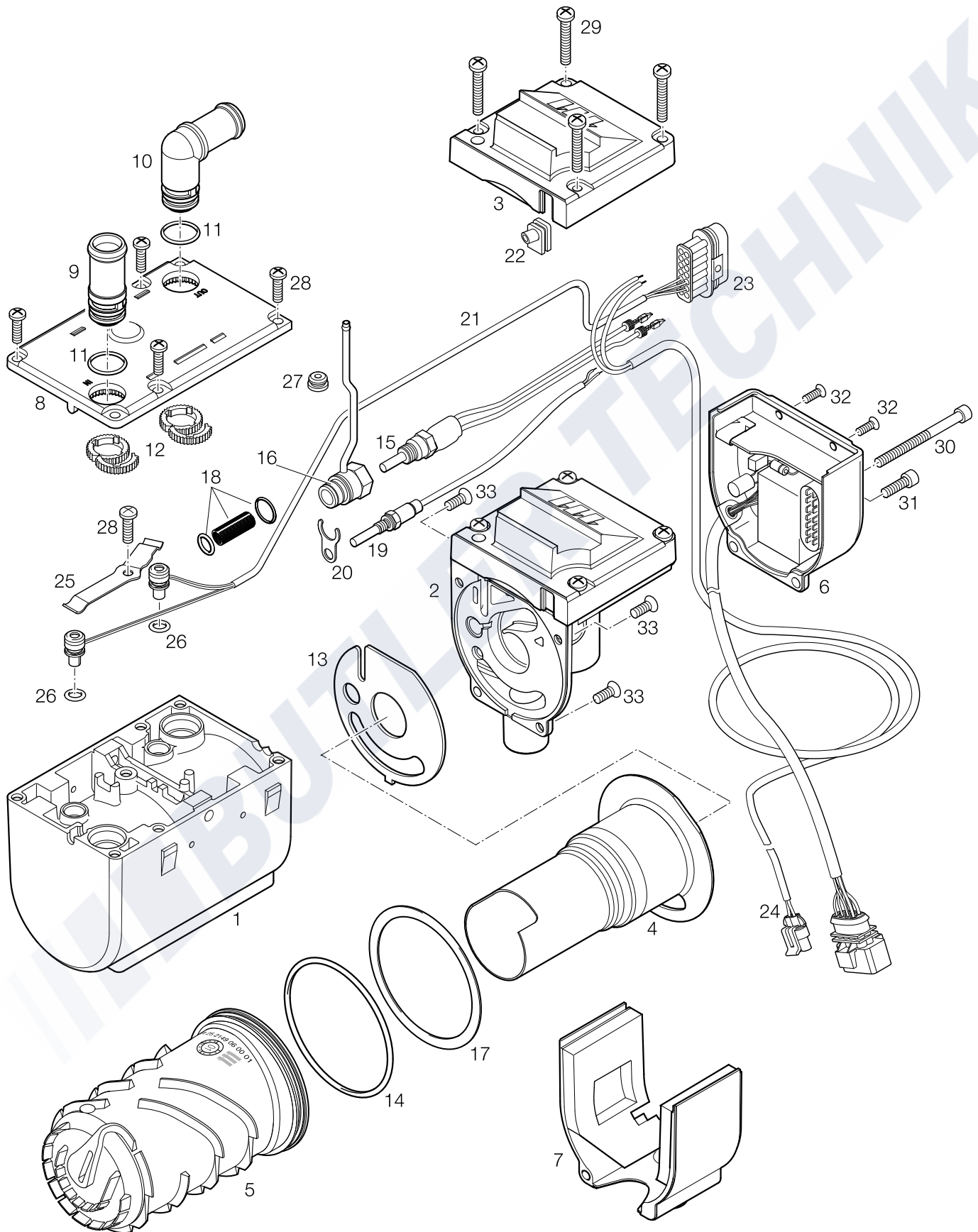



5 Repair instructions

HYDRONIC B 5 W S / D 5 W S

- 1 Jacket
- 2 Combustion air fan with cover
- 3 Fan cover – cover for combustion air fan
- 4 Combustion chamber with flame tube
- 5 Heat exchanger
- 6 Controller
- 7 Motor cover – cover for the electric motor
- 8 Jacket cover – cover for the jacket
- 9 Straight socket
- 10 90° socket
- 11 O-ring 16 x 2
- 12 Indented ring
- 13 Seal between jacket and combustion air fan
- 14 O-ring 74 x 3
- 15 Glow plug with cable
- 16 Glow plug socket
- 17 Seal between combustion chamber with flame pipe and heat exchanger
- 18 Lining with O-rings for glow plug
- 19 Sensor flame monitoring
- 20 Socket holder
- 21 Sensor cable harness
- 22 Bush for sensor cable harness
- 23 Controller connector – 14-pole connector for controller (waterproof)
- 24 Water pump cable harness
- 25 Pressure spring
- 26 O-ring 7 x 2
- 27 Bush for fuel pipe from glow plug socket
- 28 Screw Taptite M5 x 12 TORX (1x)
- 29 Screw Taptite M5 x 25 TORX (4x)
- 30 Cap screw M5 x 65 TORX (1x)
- 31 Screw Taptite M5 x 16 TORX (1x)
- 32 Screw Taptite M4 x 10 TORX (2x)
- 33 Countersunk screw M5 x 12 TORX (3x)

5 Repair instructions

Repair step 1

Dismantle fan cover (fig. 1)

- Unscrew the 4 fastening screws of the fan cover and pull the fan cover carefully over the fuel connection.
Torque of the fastening screws: 4 Nm.

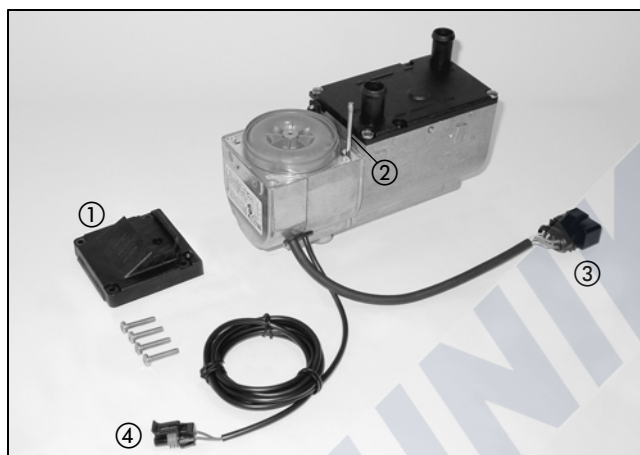

Fig. 1

- ① Fan cover
- ② Fuel connection
- ③ Cable harness controller
- ④ Cable harness water pump

Repair step 2

Dismantle jacket cover and sockets (fig. 2 and diagram 1)

(fig. 2 and diagram 1)

- Unscrew the 4 fastening screws of the jacket cover and carefully remove the jacket cover from the jacket.
- Press the socket downwards.
- Loosen the indented ring and remove the O-ring.
- Pull the socket out of the jacket cover.
- For re-assembly, fit the indented ring to the socket and place in the toothed rim of the jacket cover. If an angled socket was mounted, first the angled socket has to be aligned according to the installation position and fitted in the toothed rim of the jacket cover.
- Place the jacket cover on the jacket and fasten with the 4 fastening screws.
Torque of the fastening screws: 4 Nm.

Please note

- The two sockets of the jacket cover are sealed in the jacket with the O-rings.
- Check the O-rings before re-assembly and replace if necessary.

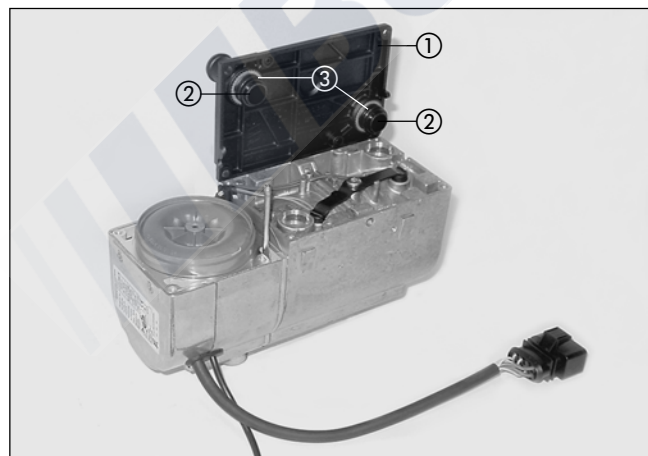

Fig. 2

- ① Jacket cover
- ② Socket
- ③ Intended ring

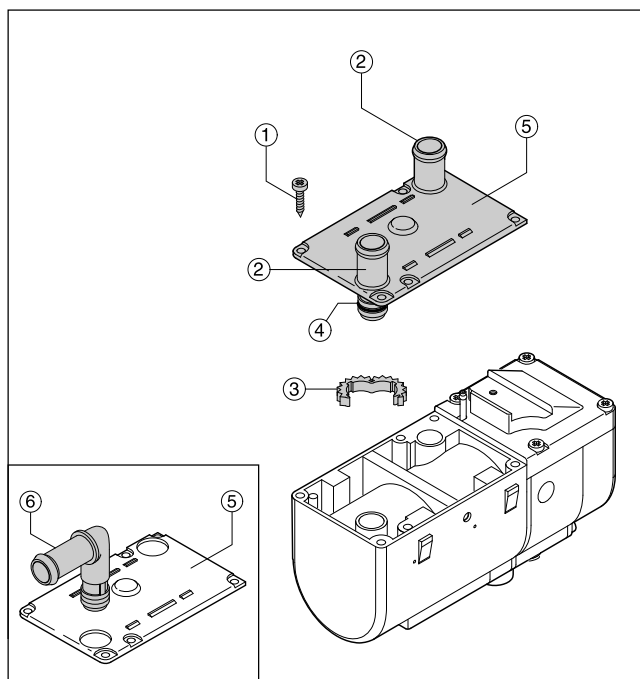

Diagram 1

- ① Fastening screws
- ② Straight socket
- ③ Indented ring
- ④ O-ring
- ⑤ Jacket cover
- ⑥ Angled socket



5 Repair instructions

Repair step 3

Dismantling the controller (fig. 3)

- Unscrew the 4 fastening screws of the controller.
- Raise the controller and remove the motor covering, ensuring that the lining is not damaged.
- Remove the controller and disconnect the 14-pole connector.
- When reassembling, first plug the 14-pole connector to the controller.
- Place the motor covering on the combustion air fan, ensuring that the lining is not damaged.
- Route all electric leads between electric motor and housing and finally insert the controller in the guide groove of the combustion air fan.
- Insert the 4 fastening screws of the controller and screw tight.

Torques:

Fastening screw, long $5.5^{+0.5}$ Nm

Fastening screw, short $3.0^{+0.5}$ Nm.

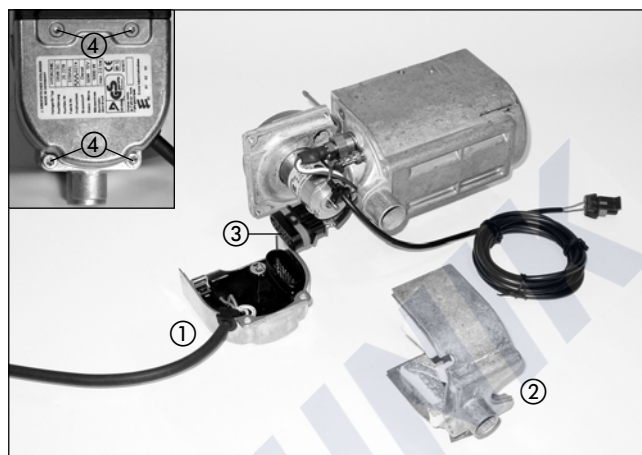

Fig. 3

- ① Controller
- ② Motor covering with lining
- ③ 14-pole connector
- ④ Fastening screws

Check controller

A basic test adapter and an adapter for the controller are required to test the controller. The adapter for the controller is used to make an electrical connection between controller and basic test adapter.

The basic test adapter is connected to the computer where the controller can now be tested with an installed test program.

Order no.: basic test adapter

22 1508 89 00 00

Order no.: adapter for controller

22 1521 89 00 00

Repair step 4

Remove glow plug (fig. 4 and 5b)

- Repair step 3, dismantle controller.
- Using an unlocking tool from AMP (order no. 206 00 205, see also page 27), unclip cable 1.5^2 white from chamber 9 of the 14-pole connector and cable 1.5^2 black from chamber 12.
- Unscrew the glow plug out of its socket.
When loosening and tightening the glow plug, hold the socket with a hexagon tool.
Torque for the glow plug: $6^{+0.5}$ Nm.
- When installing the glow plug, route the cable harness between electric motor and housing.



Fig. 4

- ① Glow plug
- ② Socket
- ③ Electric motor
- ④ Flame sensor

5 Repair instructions

Repair step 5

Remove flame sensor (fig. 5a and 5b)

- Repair step 3, dismantle controller.
- Using an unlocking tool from AMP (order no. 206 00 205, see also page 27), unclip cable 0.5² blue from chamber 1 of the 14-pole connector and cable 0.5² brown from chamber 2.
- Unscrew the flame sensor from the housing.
Torque for the flame sensor: 2.5^{+0.5} Nm.

- Check flame sensor, replace if necessary.
- When installing the flame sensor, route the cables of the flame sensor between electric motor and housing.

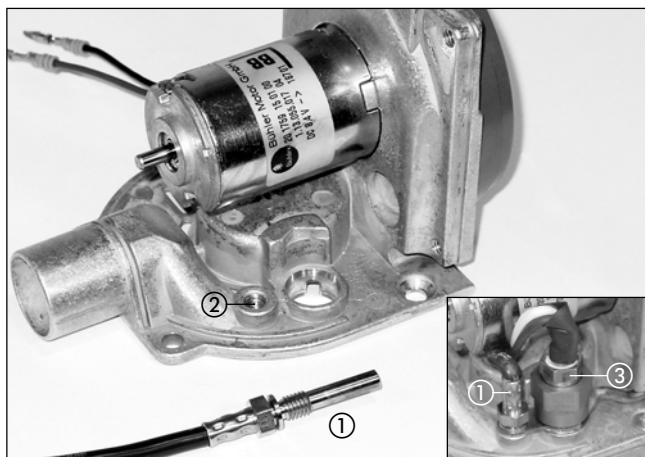

Fig. 5a

- ① Flame sensor
- ② Flame sensor bracket
- ③ Glow plug

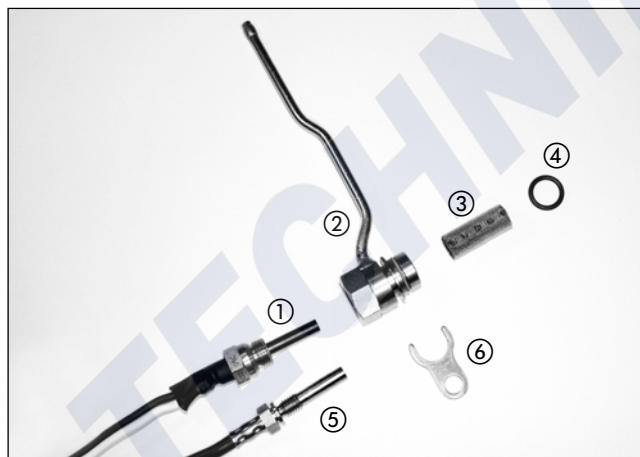

Fig. 5b

- ① Glow plug
- ② Socket
- ③ Plug filter
- ④ O-ring
- ⑤ Flame sensor
- ⑥ Bracket

Check flame sensor (diagram 2)

Check the flame sensor with a digital multimeter. If the resistance value of the flame sensor is **outside** the table of values respectively diagram, then the flame sensor must be replaced.

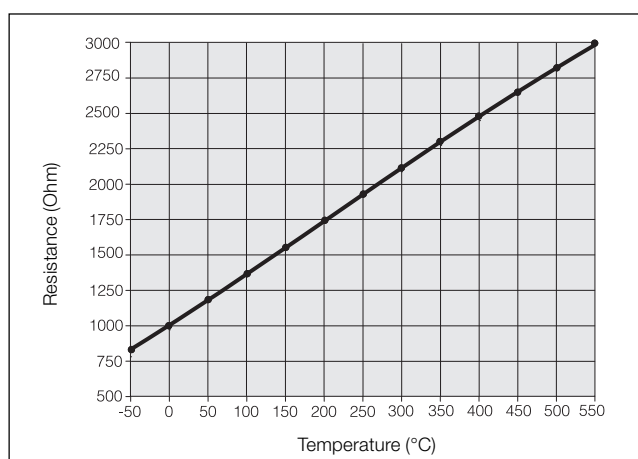

Diagram 2

Values table

Temp [°C]	-50	0	10	20	30	50	80	90	100	130	150	200	250	300	350	400
R [Ω]	803	1000	1022	1062	1097	1194	1309	1347	1385	1498	1573	1758	1941	2120	2297	2470
U [V]	1.407	1.639	1.661	1.719	1.738	1.840	1.948	1.983	2.016	2.111	2.171	2.308	2.432	2.542	2.642	2.732



5 Repair instructions

Repair step 6a

Dismantling the combustion air fan (fig. 6)

- Repair step 1, dismantle fan cover.
- Repair step 3, dismantle controller.
- Repair step 4, remove glow plug.
- Repair step 5, remove flame sensor.
- With an unlocking tool from AMP (order no. 206 00 205, see also page 27), unclip cable 0.75² brown from chamber 14 of the 14-pole connector and cable 0.75² black from chamber 13.
- Unscrew the 3 fastening screws from the combustion air fan and take the combustion air fan from the jacket. Torque for the fastening screws: 4.5^{+0.5} Nm.

Please note

Before re-assembly, carefully check the seal (item ④) between the combustion air fan and combustion chamber, and replace if necessary.

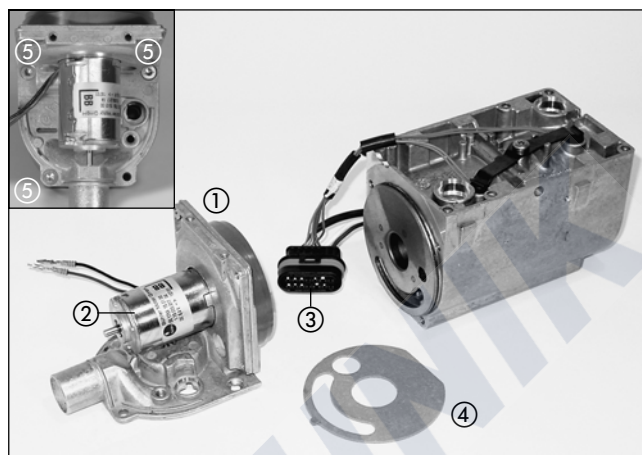

Fig. 6

- ① Combustion air fan
- ② Electric motor
- ③ 14-pole connector
- ④ Seal
- ⑤ Fastening screws

Repair step 6b

Measure the speed of the combustion air fan motor (diagram 3)

- Measure the speed of the combustion air fan motor with max 8.2 volt + 0.2 volt at *HYDRONIC* 12 volt or 15 volt + 0.2 volt at *HYDRONIC* 24 volt. To do so, unclip the cable 0.75² brown from chamber 14 of the 14-pole connector and cable 0.75² black from chamber 13.
- Apply a mark to the shaft end of the combustion air fan motor (e.g. a black-and-white disk) and measure the speed with a contact-free speed counter.
- If the measured speed < 10 000 rpm, then replace the combustion air fan.
- If the measured speed > 10 000 rpm, then replace the controller.

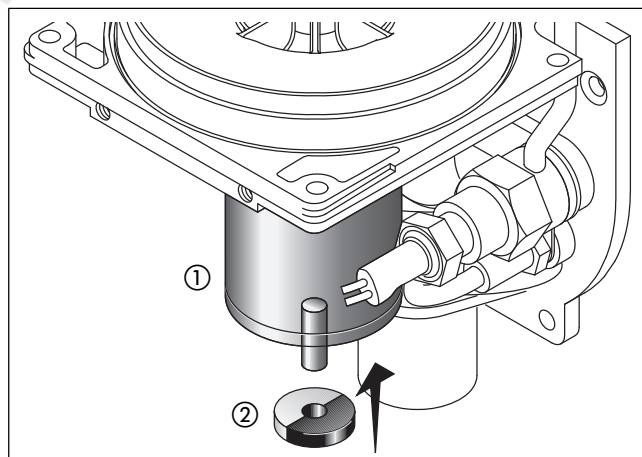

Diagram 3

- ① Electric motor
- ② Black-and-white plastic disk

5 Repair instructions

Repair step 7a

Remove plug filter (fig. 7 and diagram 4)

- Repair step 6, dismantle combustion air fan.
- Remove O-ring and pull plug filter out of the socket with round pliers.
- Check plug filter and O-ring and replace if necessary.

Repair step 7b

Remove socket (fig. 7 and diagram 4)

- Remove flame sensor with holder.
- Push socket out of housing and then swivel fuel pipe outwards.
- Clean socket. Check O-ring, replace if necessary.

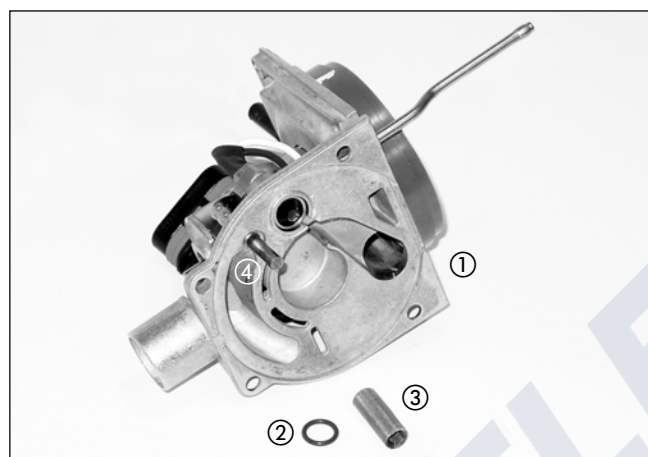

Fig. 7

- ① Combustion air fan
- ② O-ring
- ③ Plug filter
- ④ Flame sensor

Fitting socket and plug filter

- Insert socket in location hole.
- Swivel fuel pipe into basic position and then press socket into location hole.
- Place bracket in groove of socket, then put flame sensor through the hole in the bracket, insert in the threaded bore of the housing and screw tight.
- Press filter into socket as far as it will go.
- *HYDRONIC B 5 W S*:
Place O-ring on filter and insert in housing.
- *HYDRONIC D 5 W S*:
Place O-ring on filter and insert in housing.

Please note

- Welding points of filter must lie opposite the fuel intake (welding points pointing downwards).
- Before re-assembly, check O-rings carefully and replace if necessary.

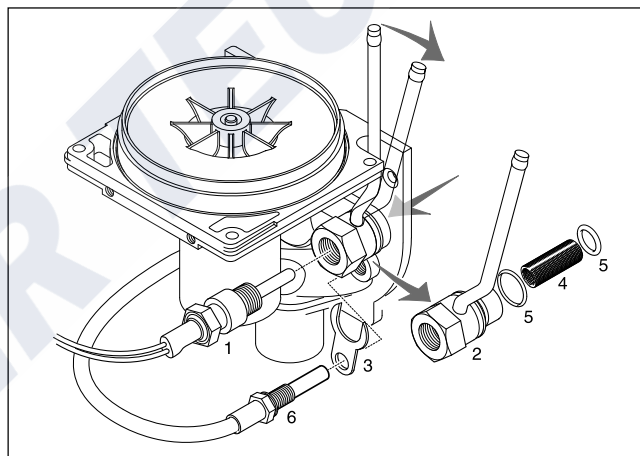

Diagram 4

- ① Glow plug
- ② Socket
- ③ Bracket
- ④ Plug filter
- ⑤ O-ring
- ⑥ Flame sensor



5 Repair instructions

Repair step 8

Remove combustion chamber (fig. 8)

- Repair step 1, dismantle fan cover.
- Repair step 3, remove controller.
- Unscrew the 3 fastening screws from the combustion air fan. Torque of the fastening screws: 4.5 ^{+0.5} Nm.
- Place the combustion air fan to one side (the cable harness of overheating sensor and temperature sensor does not have to be removed).
- Take combustion chamber out of heat exchanger (heat exchanger does not have to be removed).

Please note

Before re-assembly, carefully check the seal (item ④ and ⑤) between the combustion air fan and combustion chamber, replace if necessary.

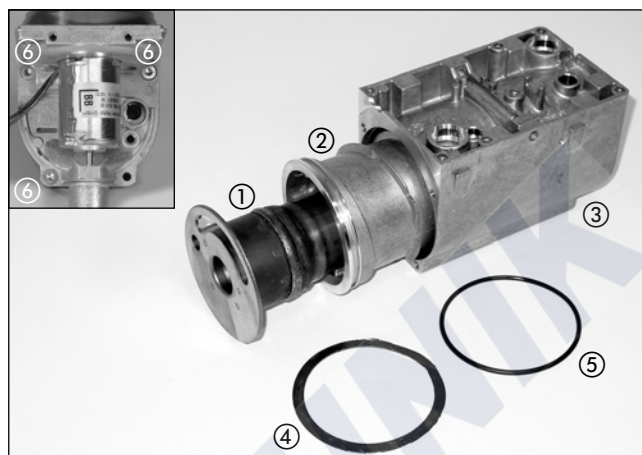

Fig. 8

- ① Combustion chamber
- ② Heat exchanger
- ③ Jacket
- ④ Seal – combustion chamber / heat exchanger
- ⑤ O-ring – heat exchanger
- ⑥ Fastening screws

Repair step 9

Remove overheating and temperature sensor (fig. 9)

- Repair step 1, dismantle fan cover.
- Repair step 2, dismantle jacket cover and sockets.
- Repair step 3, remove controller.
- Loosen fastening screw of the pressure spring and remove pressure spring.
- Lift the overheating sensor and temperature sensor with flat pliers out of the location hole in the heat exchanger.
- Using an unlocking tool by AMP (order no. 206 00 205, see page 27), unclip both temperature sensor cables from the 14-pole connector (chamber 3, cable 0.5² blue and chamber 4 cable 0.5² blue) and unclip both overheating sensor cables (chamber 5, cable 0.5² red and chamber 6 cable 0.5² red).

Please note

- Overheating sensor, temperature sensor and cable harness make up one component and are therefore not available individually when spare parts are required.
- During re-assembly, grease the O-rings of the overheating sensor and temperature sensor with special grease.

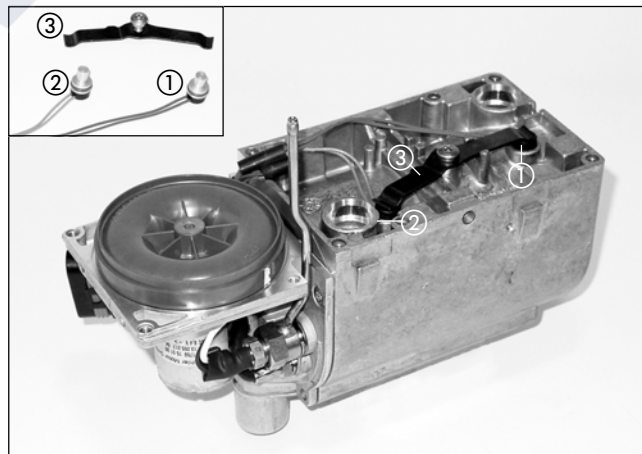

Fig. 9

- ① Overheating sensor
- ② Temperature sensor
- ③ Pressure spring

5 Repair instructions

Check overheating and temperature sensor (Diagram 5)

Check the overheating sensor respectively temperature sensor with a digital multimeter.

If the resistance value is outside the table of values respectively diagram, then the overheating sensor respectively temperature sensor must be replaced.

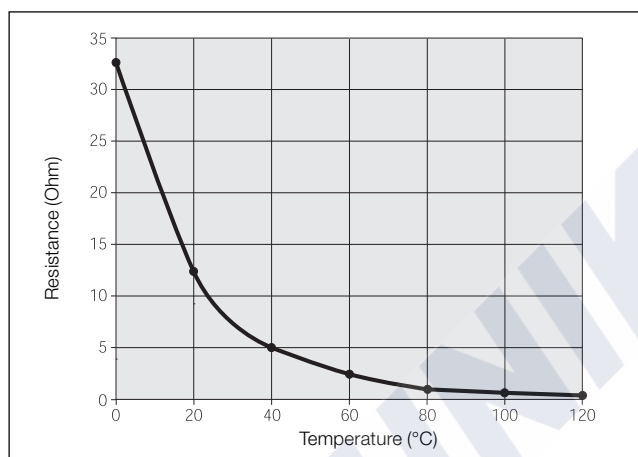

Diagram 5

Values table

Temp [°C]	0	10	20	30	40	50	60	70	80	90	100	110	120
R [kΩ]	32.54	19.87	12.48	8.06	5.33	3.60	2.48	1.75	1.25	0.91	0.67	0.50	0.38
U [V]	4.275	3.960	3.561	3.100	2.611	2.135	1.705	1.339	1.041	0.805	0.622	0.483	0.376

Repair step 10

Remove heat exchanger (fig. 10)

- Repair step 6, remove combustion air fan.
- Repair step 8, remove combustion chamber.
- Repair step 9, remove overheating and temperature sensor.
- Using a screwdriver, press the heat exchanger out of the jacket through the water inlet.
- Check the heat exchanger thoroughly, if necessary clean or replace.

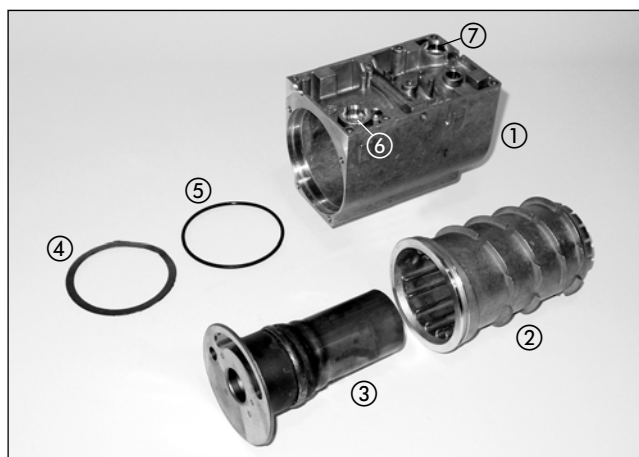

Fig. 10

- ① Jacket
- ② Heat exchanger
- ③ Combustion chamber
- ④ Seal – combustion chamber / heat exchanger
- ⑤ O-ring – heat exchanger
- ⑥ Water discharge
- ⑦ Water intake



5 Repair instructions

Repair step 11

Re-mount heat exchanger (fig. 11)

- Place the heat exchanger in the jacket: the groove in the bottom of the heat exchanger must fit in the stopper in the jacket bottom.

As a guide, the socket for the overheating sensor must match the location hole in the jacket.

Please note

- Before assembly, carefully check the seals and O-ring and replace if necessary.
- Check that the heat exchanger fits properly in the jacket (the heater exchanger has to be pressed firmly into the jacket).
- Grease the O-ring with special grease before fitting in position.

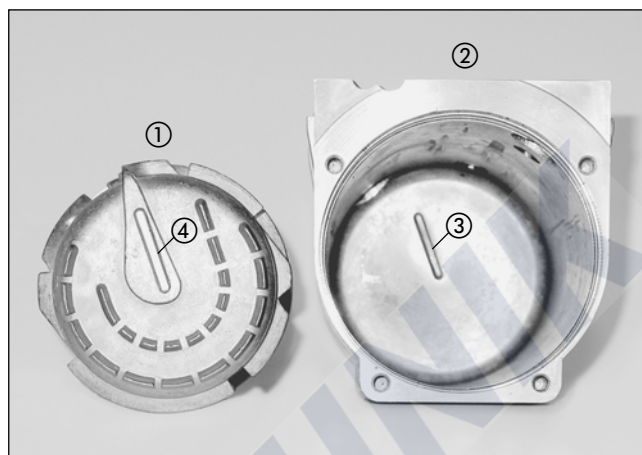

Fig. 11

- ① Heat exchanger
- ② Jacket
- ③ Stopper
- ④ Groove in heat exchanger bottom

Measuring the fuel quantity

Preparing the measurement (diagram 6)

- Pull the fuel pressure pipe from *HYDRONIC* and place it in a measuring beaker (10 cm³).
- Switch *HYDRONIC* on.
After 45 sec. the dosing pump starts to pump fuel.
If the fuel comes out in an even, bubble-free flow, then the fuel pipe is filled and vented.
- Switch the heater off and drain the beaker.

Measuring

- Switch *HYDRONIC* on.
After 45 sec. the dosing pump starts to pump fuel.
- During measurement, hold the beaker on the same level as *HYDRONIC*.
The fuel pump function is automatically switched off after 90 sec.
- Switch *HYDRONIC* off as otherwise it will start up again.
- Read off the quantity of fuel in the beaker.

Fuel quantity

Evaluation

- Compare the measured fuel quantity with the values in the table shown below.
If the measured fuel quantity is over the maximum value or under the minimum value, then the dosing pump has to be replaced.

Please note

Only measure the fuel flow when the battery is sufficiently charged.

During the measurement, the controller should have min. 11 / 23 volt or max. 13 / 25 volt.

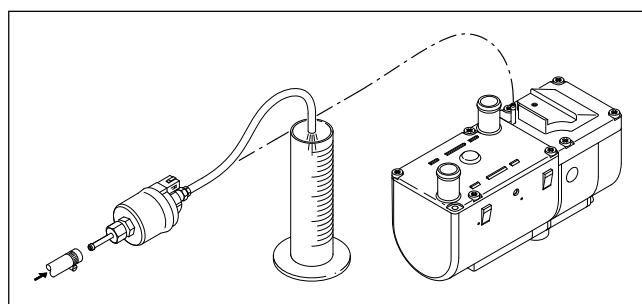

Diagram 6

Nominal quantity	<i>HYDRONIC</i> B 5 W S	<i>HYDRONIC</i> D 5 W S
Nominal fuel quantity	11.3 cm ³ / 90 sec	8.9 cm ³ / 85 sec
Max. fuel quantity	11.9 cm ³ / 90 sec	9.5 cm ³ / 85 sec
Min. fuel quantity	10.7 cm ³ / 90 sec	8.3 cm ³ / 85 sec

6 Wiring diagram

Wiring diagram

HYDRONIC B 5 W S / D 5 W S – 12 volt

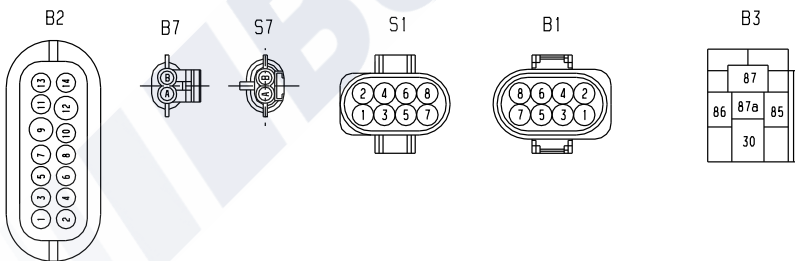
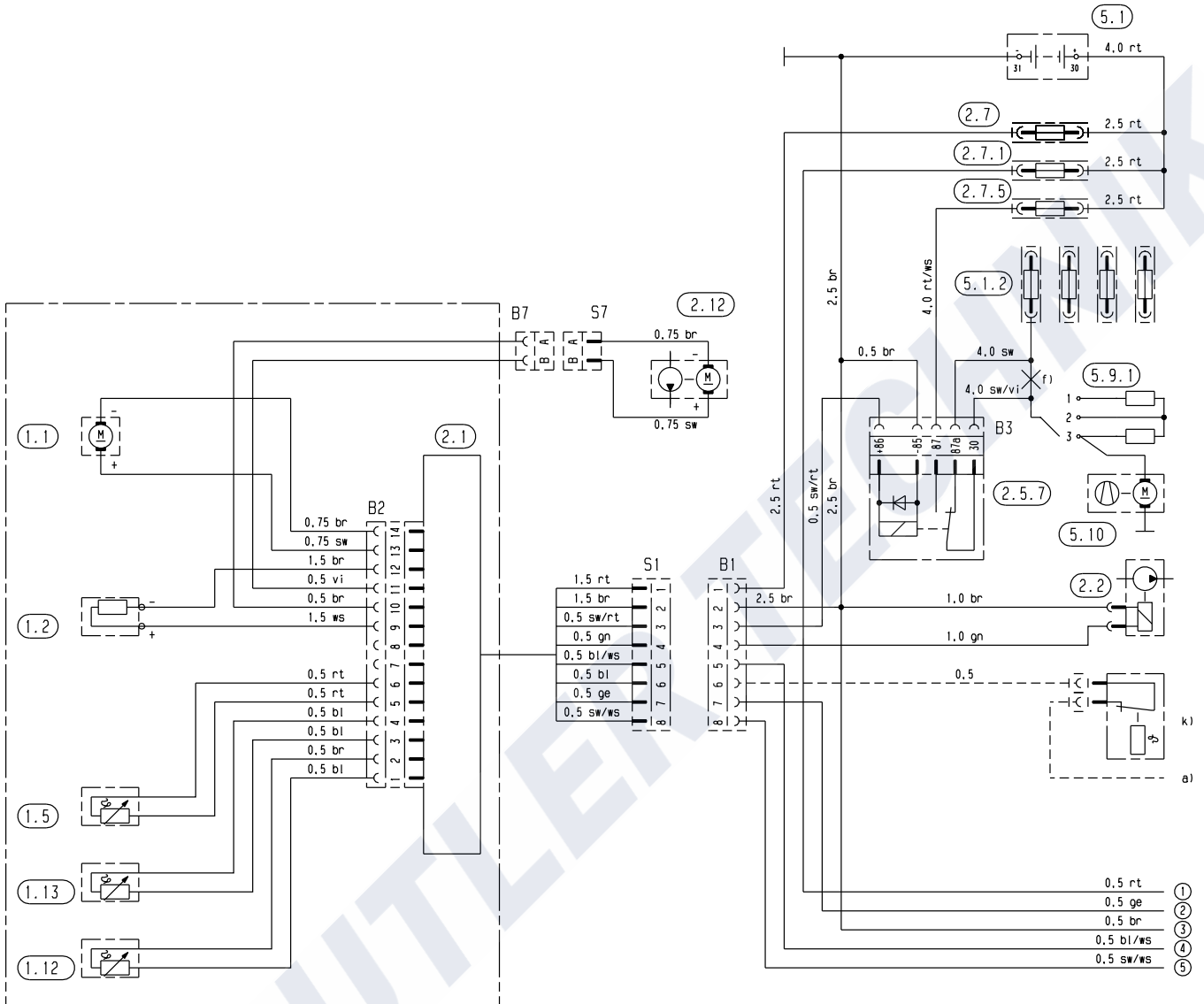



6 Wiring diagram

Parts list

- 1.1 Heater motor
- 1.2 Glow plug
- 1.5 Overheating sensor

- 1.12 Flame sensor
- 1.13 Temperature sensor

- 2.1 Controller
- 2.2 Fuel dosing pump
- 2.5.7 Relay, vehicle fan
- 2.7 Main fuse 20 A
- 2.7.1 Fuse, actuation 5 A
- 2.7.5 Fuse, vehicle fan 25 A
- 2.12 Water pump

- 5.1 Battery
- 5.1.2 Fuse block in the vehicle
- 5.9.1 Switch, vehicle fan
- 5.10 Vehicle fan

- a) connect to D+ for pre-heating option
- f) split lead
- k) switch
(pre-heating, e.g. outside temperature < 5°C
or summer / winter changeover switch)

Length "plus" + length "minus":

< 5 m: cross section 4 mm²

> 5 m < 8 m: cross section 6 mm²



Caution

Unused lead ends can cause a short circuit and damage
HYDRONIC.

➔ Insulate unused lead ends.

Connectors and socket housings are shown from the lead in-
let side.

Cable colours

- rt = red
- bl = blue
- ws = white
- sw = black
- gn = green
- gr = grey
- ge = yellow
- vi = violet
- gr = brown
- li = lilac

6 Wiring diagram

Wiring diagram Controls – 12 volt, part 1

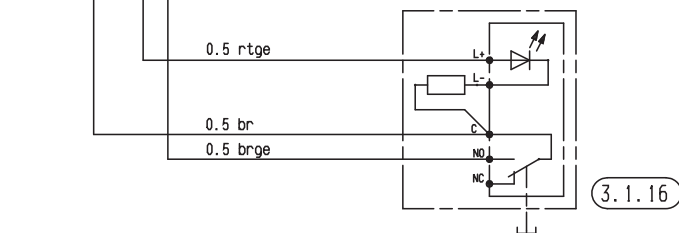
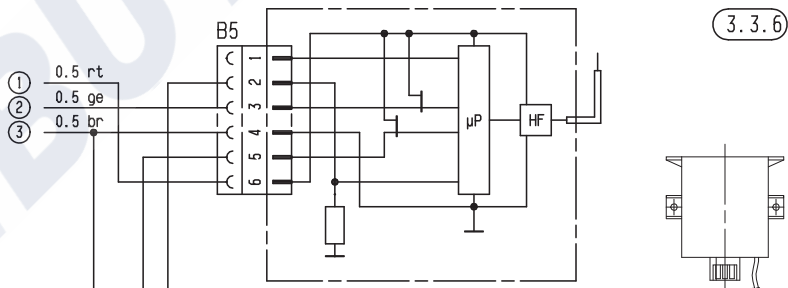
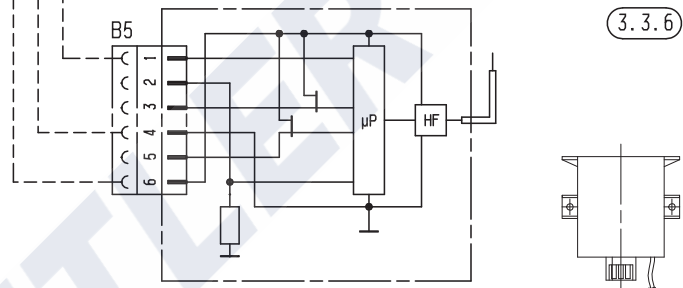
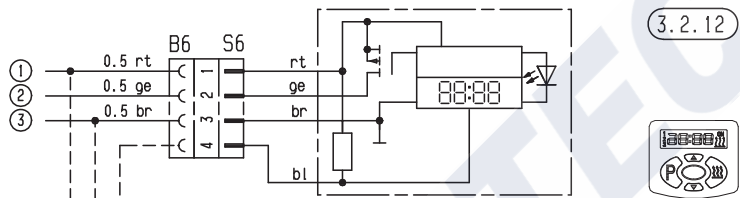
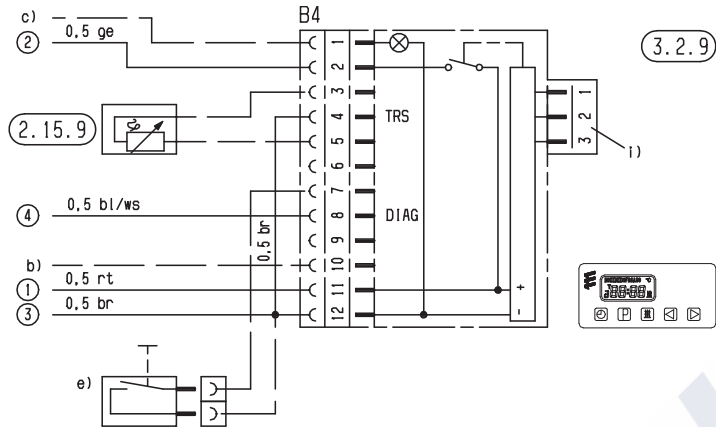



6 Wiring diagram

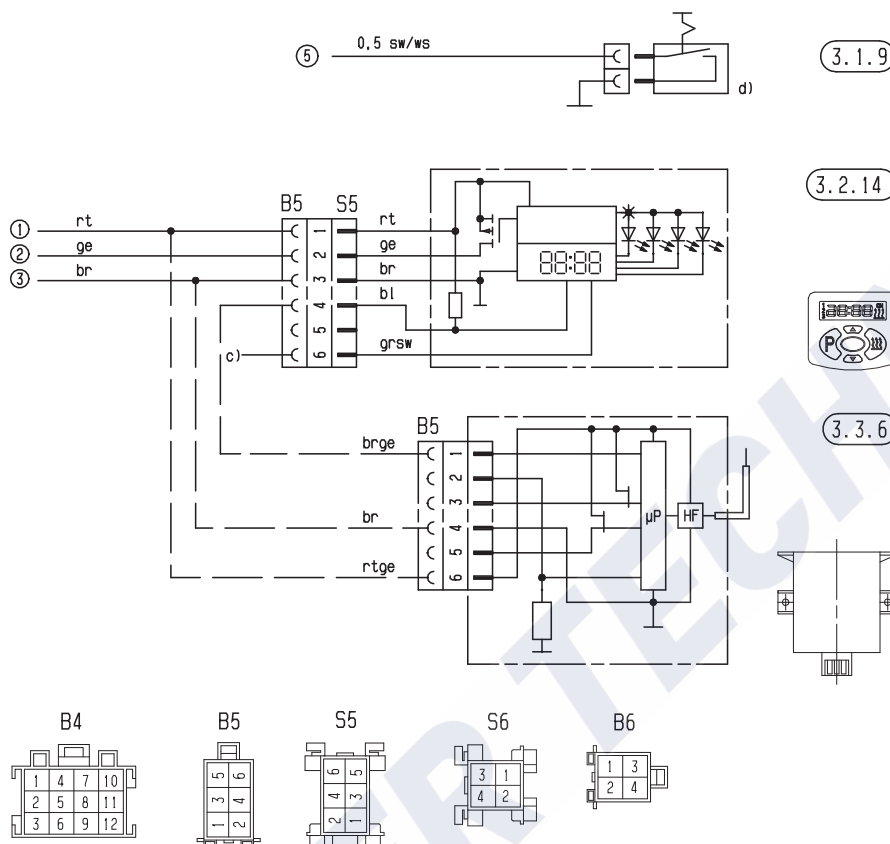

25 1920 00 97 01 C

Parts list

- 2.15.9 Sensor, outside temperature
- 3.1.9 Changeover switch "heating / venting"
- 3.1.16 Button, radio remote control
- 3.2.9 Timer, module clock
- 3.2.12 Timer, mini 12 / 24 volt
- 3.2.14 Timer, mini lighting blue – 12 volt only
- 3.3.6 Radio remote control (receiver) TP41i
- b) Connect to terminal +15
if heating mode required for > 2 hrs
(with ignition switched on)
- c) lighting terminal 58
- d) pre-venting with vehicle fan (option)
- e) external button ON / OFF (option)
- i) Connection radio module receiver TP41i

Length "plus" + length "minus":
 < 5 m: cross section 4 mm²
 > 5 m < 8 m: cross section 6 mm²



Caution

Unused lead ends can cause a short circuit and damage *HYDRONIC*.

➔ Insulate unused lead ends.

Connectors and socket housings are shown from the lead inlet side.

Please note

In vehicles with automatic heating or air-conditioning, please follow the workshop instructions for the vehicle concerned regarding fan control. If no workshop instructions have been issued, please follow the instructions issued by the vehicle manufacturer regarding the connection or interface for fan control.

Cable colours

- | | |
|------------|-------------|
| rt = red | gr = grey |
| bl = blue | ge = yellow |
| ws = white | vi = violet |
| sw = black | gr = brown |
| gn = green | li = lilac |

6 Wiring diagram

Wiring diagram Controls – 12 volt, part 2

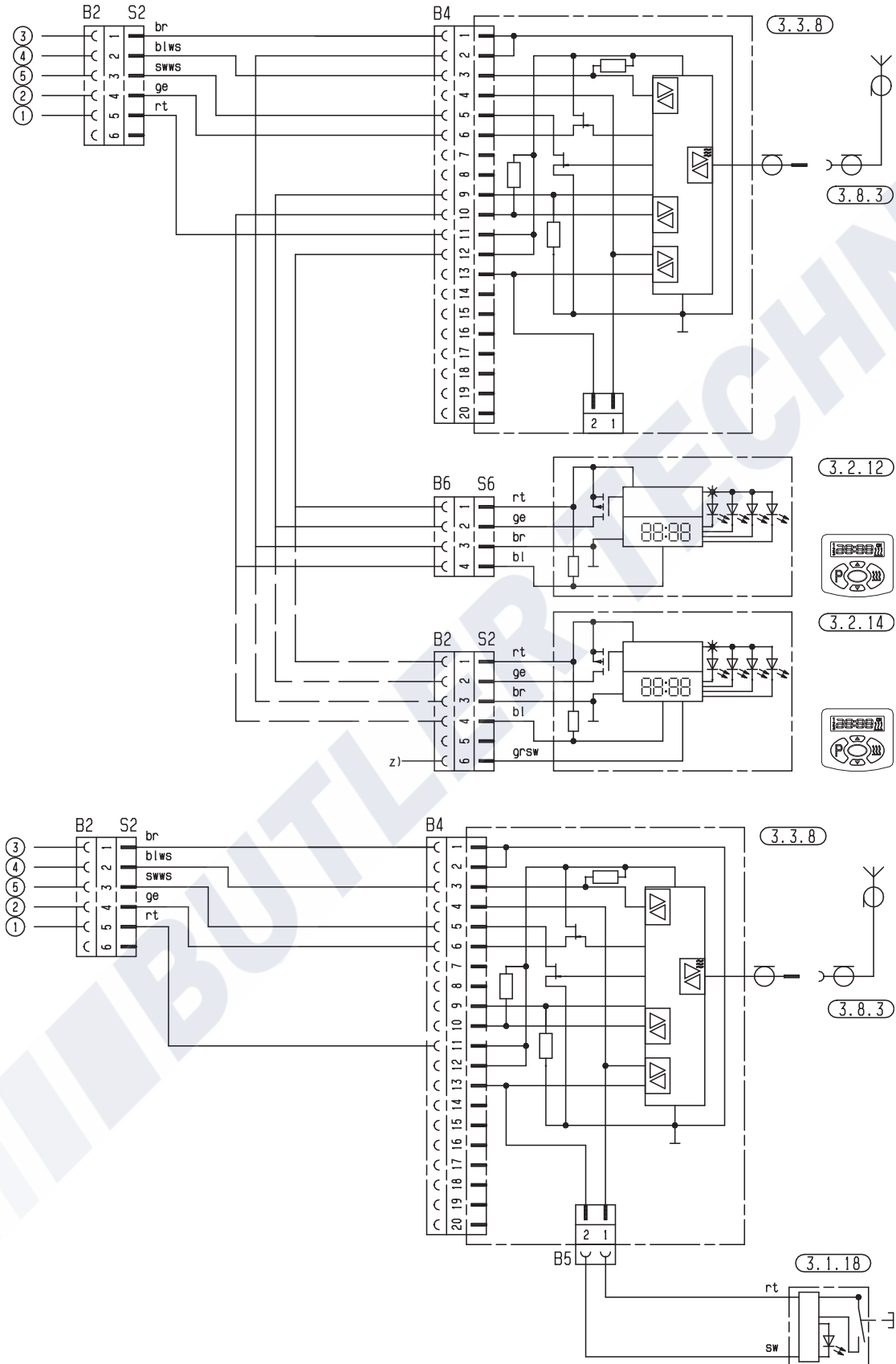



6 Wiring diagram

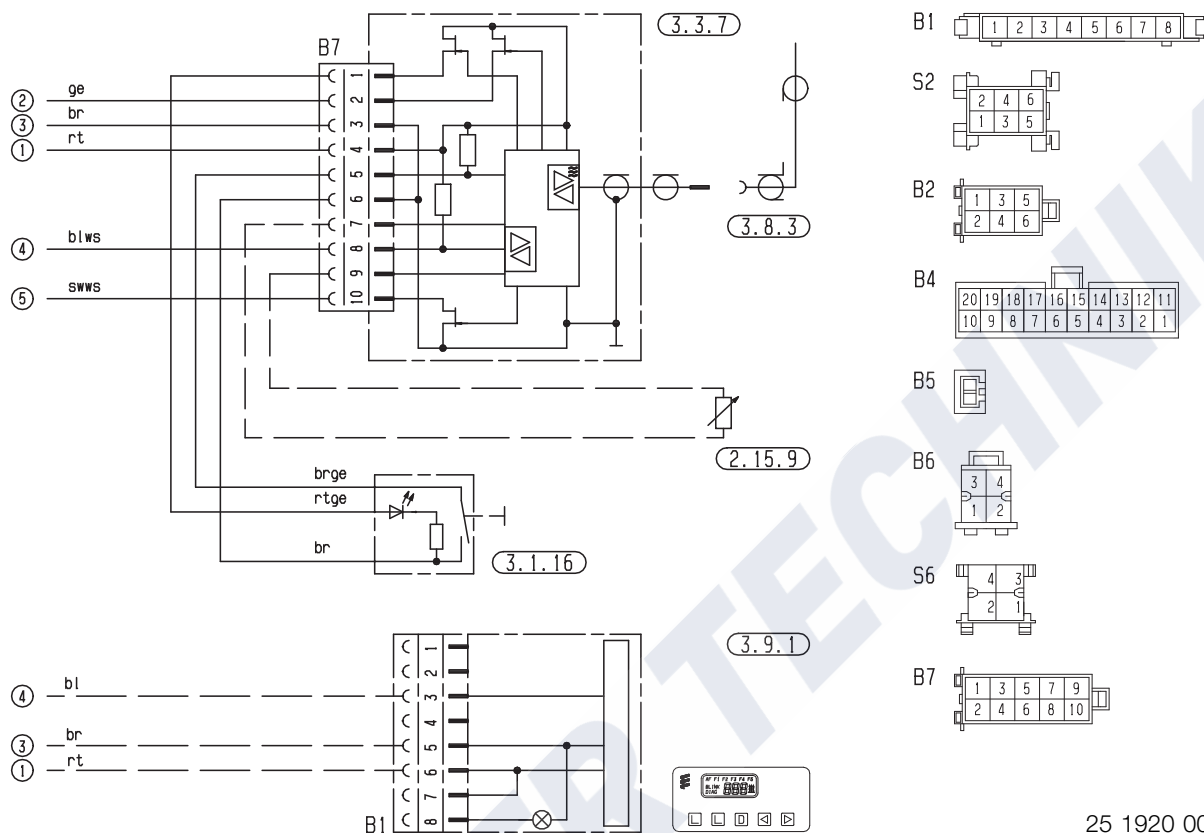

25 1920 00 97 02 A

Parts list

- 2.15.9 Sensor, outside temperature
- 3.1.16 Button, radio remote control
- 3.1.18 Button, CALLTRONIC
- 3.2.12 Timer, mini 12 V / 24 V
- 3.2.14 Timer, mini lighting blue – 12 volt only
- 3.3.7 Radio remote control TP5
- 3.3.8 Remote control, CALLTRONIC
- 3.8.3 Antenna
- 3.9.1 Diagnosis instrument JE diagnosis
- z) Terminal 58 (lighting)

Length “plus” + length “minus”:
 < 5m: cross section 4 mm²
 > 5 m < 8 m: cross section 6 mm²

Caution

Unused lead ends can cause a short circuit and damage HYDRONIC.
 ➔ Insulate unused lead ends.

Connectors and socket housings are shown from the lead inlet side.

Please note

In vehicles with automatic heating or air-conditioning, please follow the workshop instructions for the vehicle concerned regarding fan control. If no workshop instructions have been issued, please follow the instructions issued by the vehicle manufacturer regarding the connection or interface for fan control.

Cable colours

- | | |
|------------|-------------|
| rt = red | gr = grey |
| bl = blue | ge = yellow |
| ws = white | vi = violet |
| sw = black | gr = brown |
| gn = green | li = lilac |

6 Wiring diagram

Wiring diagram
HYDRONIC D 5 W S – 24 volt

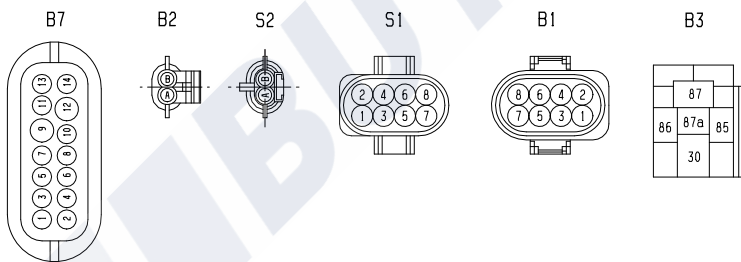
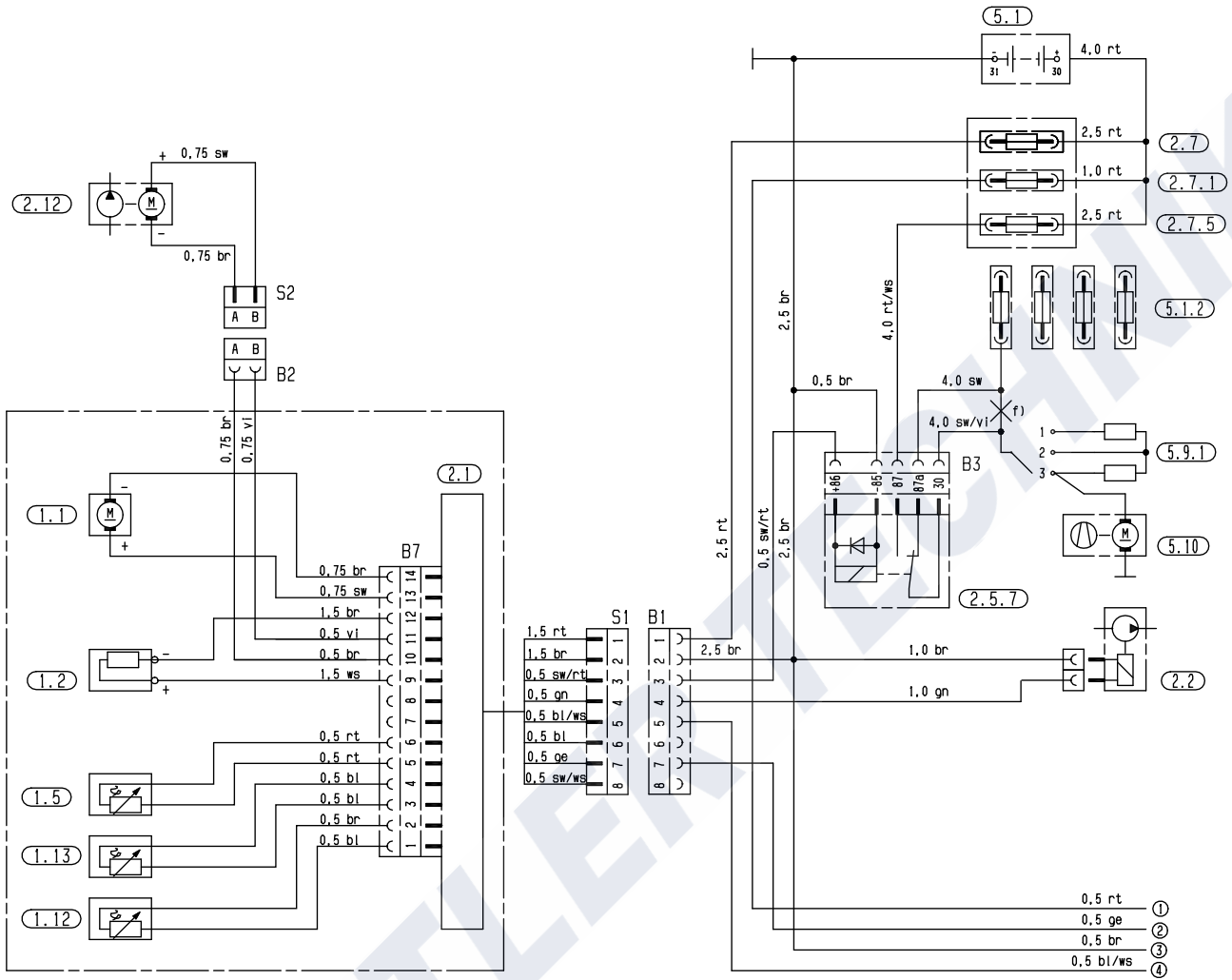



6 Wiring diagram

Wiring diagram Controls – 24 volt

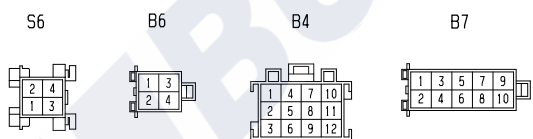
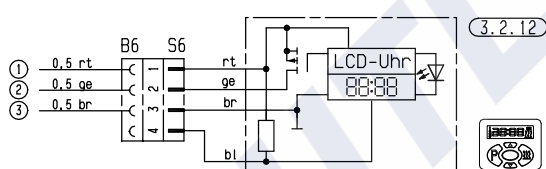
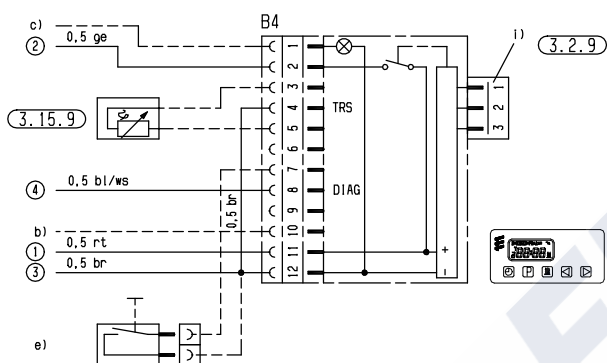
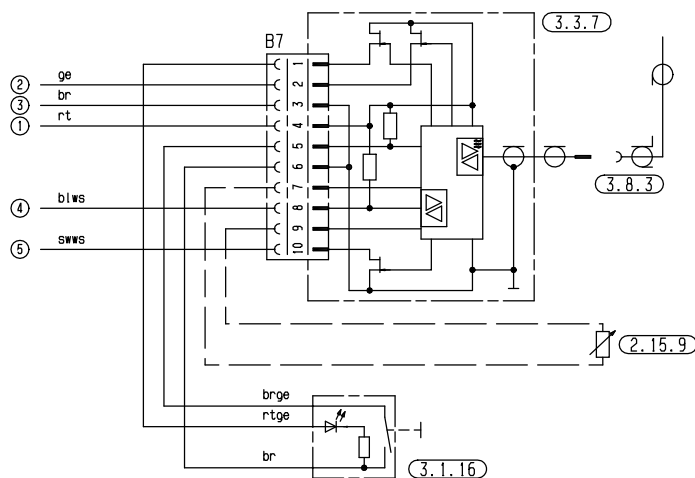

25 2147 00 96 01 D

Cable colours

- rt = red
- bl = blue
- ws = white
- sw = black
- gn = green
- gr = grey
- ge = yellow
- vi = violet
- gr = brown
- li = lilac

Parts list

- 1.1 Heater motor
 - 1.2 Glow plug
 - 1.5 Overheating sensor
 - 1.12 Flame sensor
 - 1.13 Temperature sensor
 - 2.1 Controller
 - 2.2 Fuel dosing pump
 - 2.5.7 Relay, vehicle fan
 - 2.7 Main fuse 15 A
 - 2.7.1 Fuse, actuation 5 A
 - 2.7.5 Fuse, vehicle fan 25 A
 - 2.12 Water pump
 - 2.15.9 Sensor, outside temperature
 - 3.1.16 Button, radio remote control
 - 3.2.9 Timer, module clock, TRS
 - 3.2.12 Timer, mini
 - 3.3.7 Radio remote control TP5
 - 3.8.3 Antenna
 - 5.1 Battery
 - 5.1.2 Fuse block in the vehicle
 - 5.9.1 Switch, vehicle fan
 - 5.10 Vehicle fan
- b) Connect to terminal +15
 c) lighting terminal 58
 e) external button ON / OFF (option)
 f) split lead
 i) Connection radio module receiver TP4i

Length "plus" + length "minus":
 < 5 m: cross section 4 mm²
 > 5 m < 8 m: cross section 6 mm²

Caution

Unused lead ends can cause a short circuit and damage **HYDRONIC**.

➔ Insulate unused lead ends.

Connectors and socket housings are shown from the lead inlet side.

Please note

In vehicles with automatic heating or air-conditioning, please follow the workshop instructions for the vehicle concerned regarding fan control. If no workshop instructions have been issued, please follow the instructions issued by the vehicle manufacturer regarding the connection or interface for fan control.

6 Wiring diagram

Wiring diagram
HYDRONIC D 5 W S – 24 volt, GGVS / TRS003 / ADR / ADR99

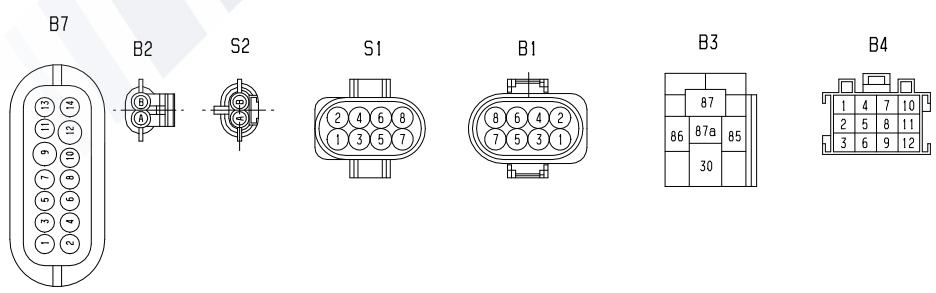
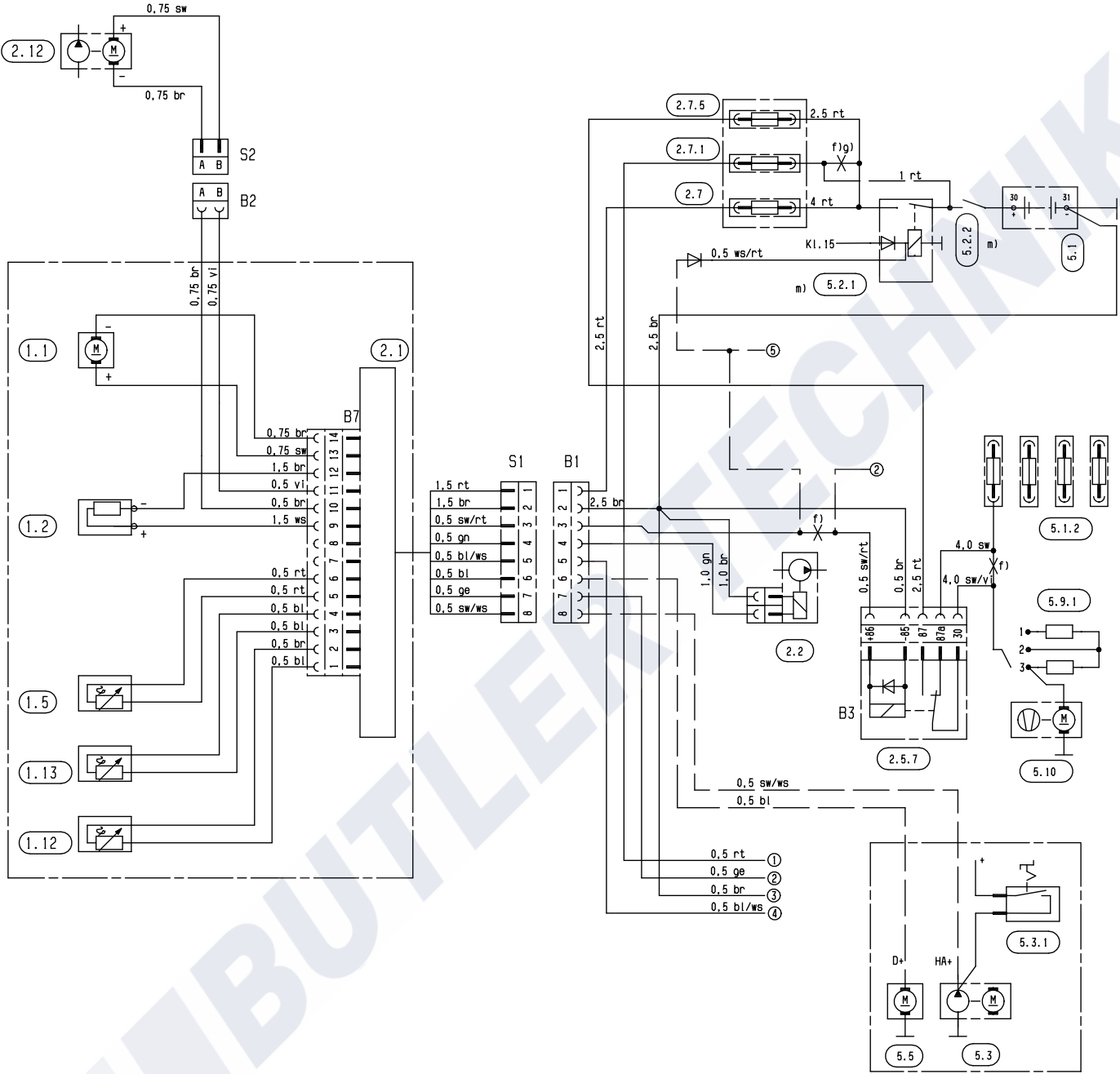



6 Wiring diagram

Wiring diagram

Controls – 24 volt, GGVS / TRS003 / ADR / ADR99

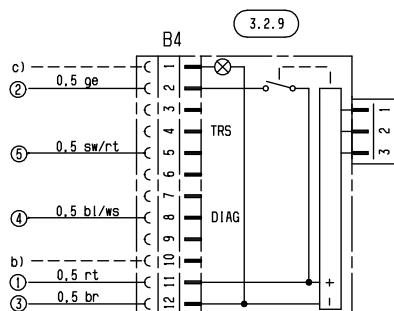

25 2147 00 97 01 C

Cable colours

rt = red
 bl = blue
 ws = white
 sw = black
 gn = green
 gr = grey
 ge = yellow
 vi = violet
 gr = brown
 li = lilac

Parts list

- 1.1 Heater motor
- 1.2 Glow plug
- 1.5 Overheating sensor

- 1.12 Flame sensor
- 1.13 Temperature sensor

- 2.1 Controller
- 2.2 Fuel dosing pump
- 2.5.7 Relay, vehicle fan
- 2.7 Main fuse 15 A
- 2.7.1 Fuse, actuation 5 A
- 2.7.5 Fuse, vehicle fan 25 A
- 2.12 Water pump

- 3.2.9 Timer, module clock, TRS

- 5.1 Battery
- 5.1.2 Fuse block in the vehicle
- 5.2.1 Battery operating switch m)
(operation e.g. controlled via ignition lock)
- 5.2.2 Battery separating switch m)
(Emergency-shutdown function in the case of GGVS / TRS 003 / ADR / ADR 99)

- 5.3 Accessory drive HA+
- 5.3.1 Switch auxiliary drive
- 5.5 Generator D+
- 5.9.1 Switch, vehicle fan
- 5.10 Vehicle fan

- b) Connect to terminal +15

- c) lighting terminal 58

- f) split lead

- g) Insulate cable and tie back

- m) if only one control element is used for items 5.2.1 and 5.2.2, it must be ensured that, if the function 'opening of battery separating switch' is actuated (emergency shutdown-function in the case of GGVS / TRS 003 / ADR / ADR 99) and similar), the switch always breaks contact without delay (without consideration for the heater mode) and breaks all of the heater's circuits from the battery.

Length "plus" + length "minus":
 < 5 m: cross section 4 mm²
 > 5 m < 8 m: cross section 6 mm²



Caution

Unused lead ends can cause a short circuit and damage *HYDRONIC*.

➔ Insulate unused lead ends.

Connectors and socket housings are shown from the lead inlet side.

Please note

The cables drawn in as dashed lines have to be additionally laid and connected. Prior to doing so, disconnect the wire harness at the positions marked with f). Cable seals and push-on contacts for the connector B1 and the ventilator relay are contained in the installation kit.

The vehicle ventilator runs immediately after the heater has been started.

In vehicles with automatic heating or air-conditioning, please follow the workshop instructions for the vehicle concerned regarding fan control. If no workshop instructions have been issued, please follow the instructions issued by the vehicle manufacturer regarding the connection or interface for fan control.

6 Wiring diagram

Parts list for control units circuit diagrams EasyStart

- 2.15.1 Temperature sensor (room temperature)
(included in the EasyStart R+ scope of supply,
optional for EasyStart T and EasyStart R)
- 2.15.9 External temperature sensor (optional)

- 3.1.7 "ON / OFF" pushbutton (option)
- 3.1.9 "Heat / ventilate" switch (option)
- 3.1.16 Radio remote control button

- 3.2.15 EasyStart T timer

- 3.3.9 EasyStart R radio remote control
(stationary unit)
- 3.3.10 EasyStart R+ radio remote control
(stationary unit)

- 3.6.1 Lead harness

- 3.8.3 Antenna

- c) Terminal 58 (lighting)
- d) Parking ventilation with vehicle blower (optional)
- e) EasyStart T timer connection
- g) External "ON / OFF" button (optional)
- x) ADR jumper

Connectors and bush housings are shown from the cable inlet side.

Cable colours

- rt = red
- bl = blue
- ws = white
- sw = black
- gn = green
- gr = grey
- ge = yellow
- vi = violet
- br = brown
- li = purple



6 Wiring diagram

Wiring diagram Controls – EasyStart R +

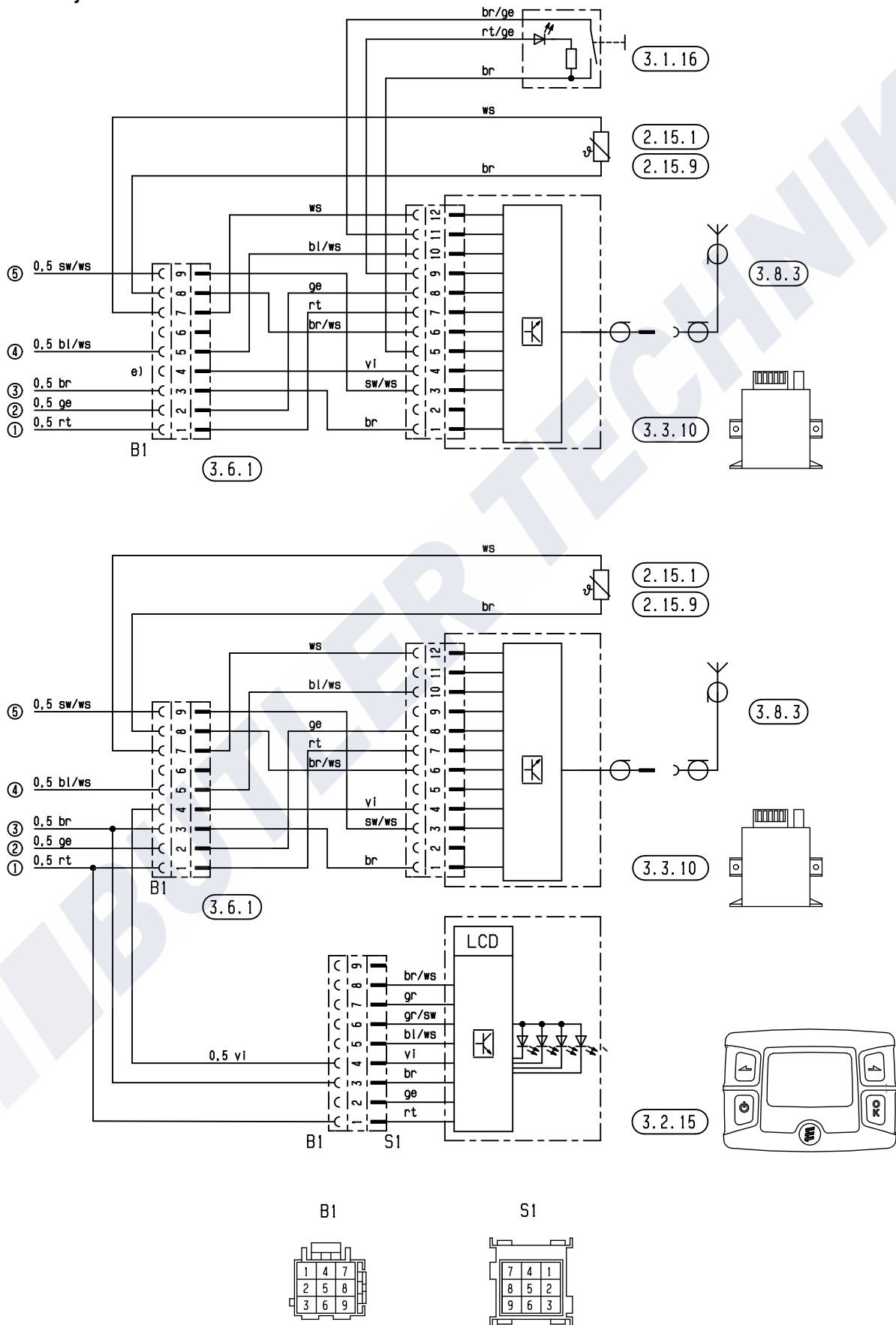

6 Wiring diagram

Wiring diagram Controls – EasyStart R

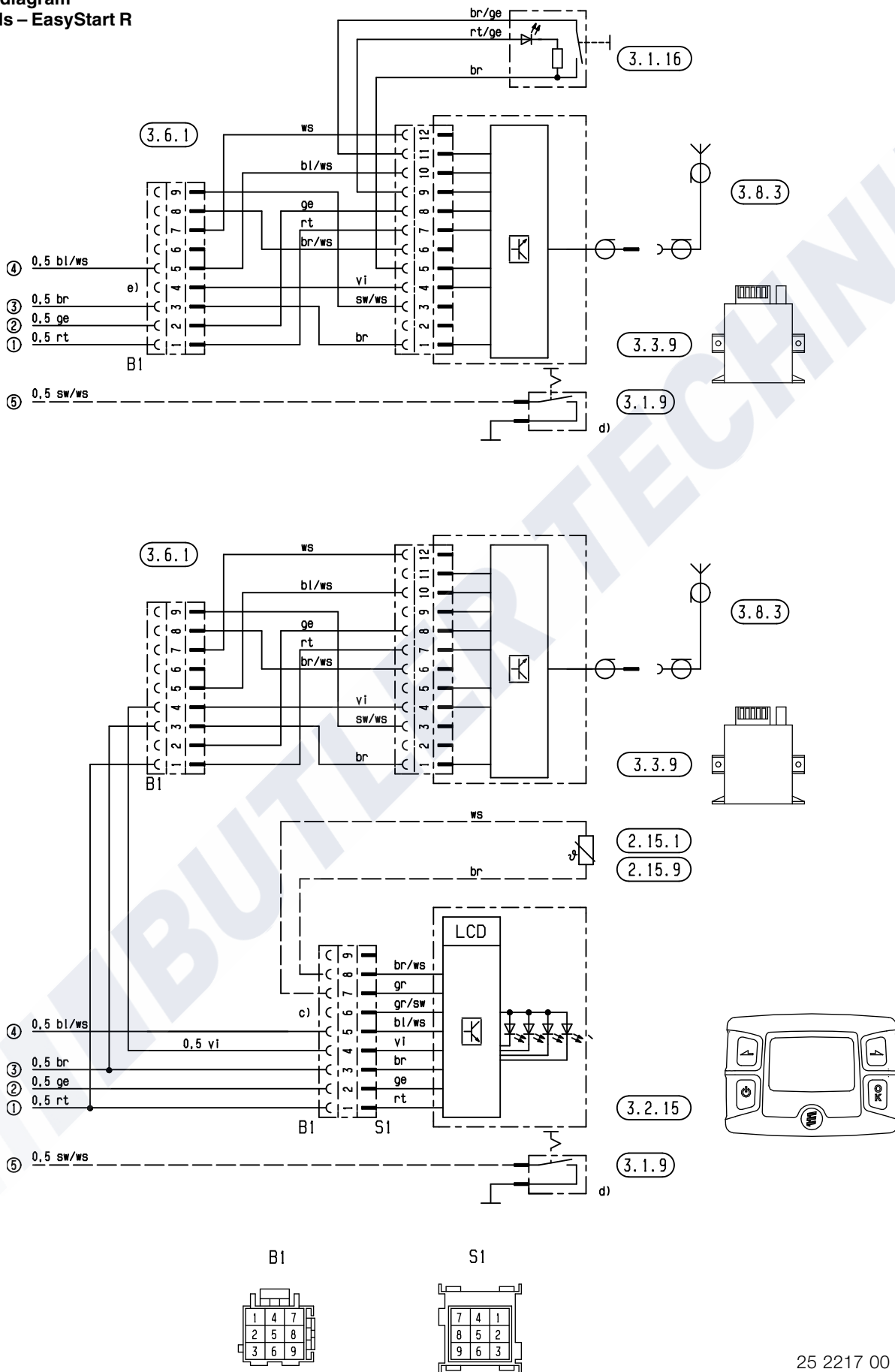



6 Wiring diagram

Wiring diagram Controls – EasyStart T

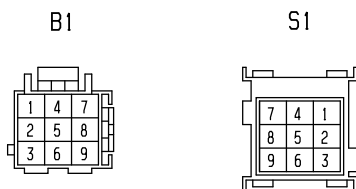
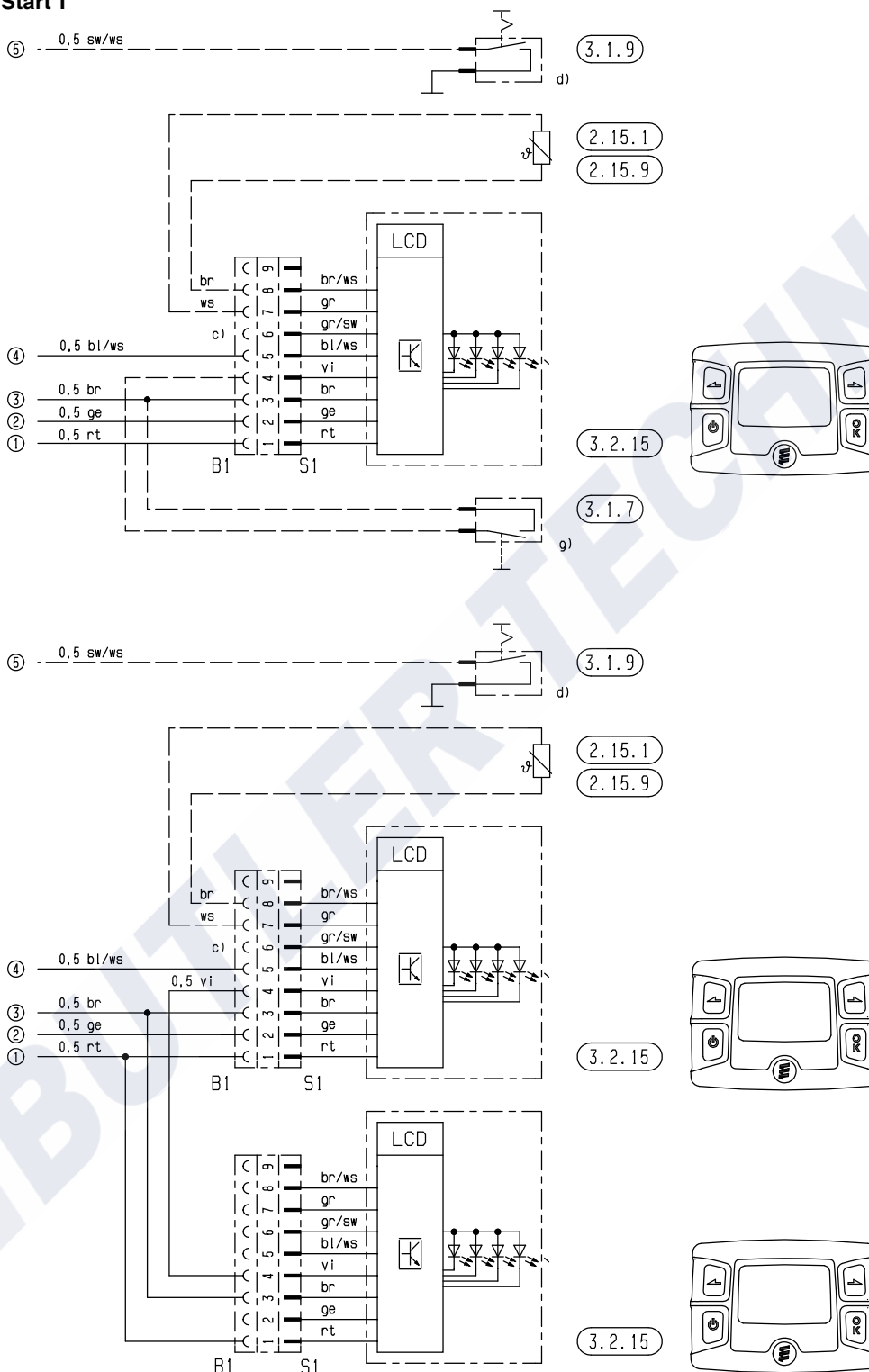

6 Wiring diagram

Wiring diagram
Controls – EasyStart T / ADR

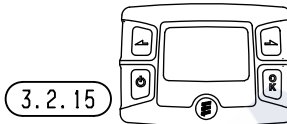
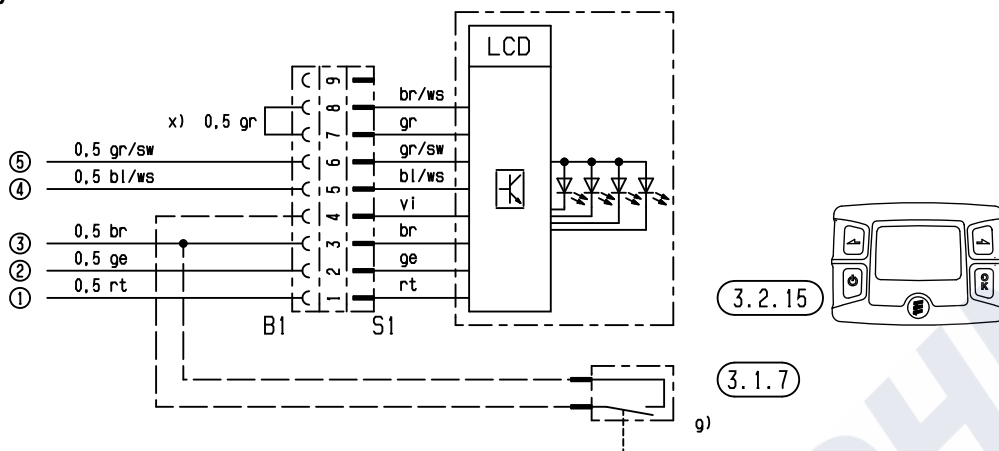

3.1.7

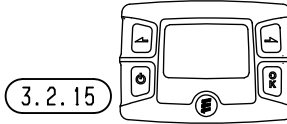
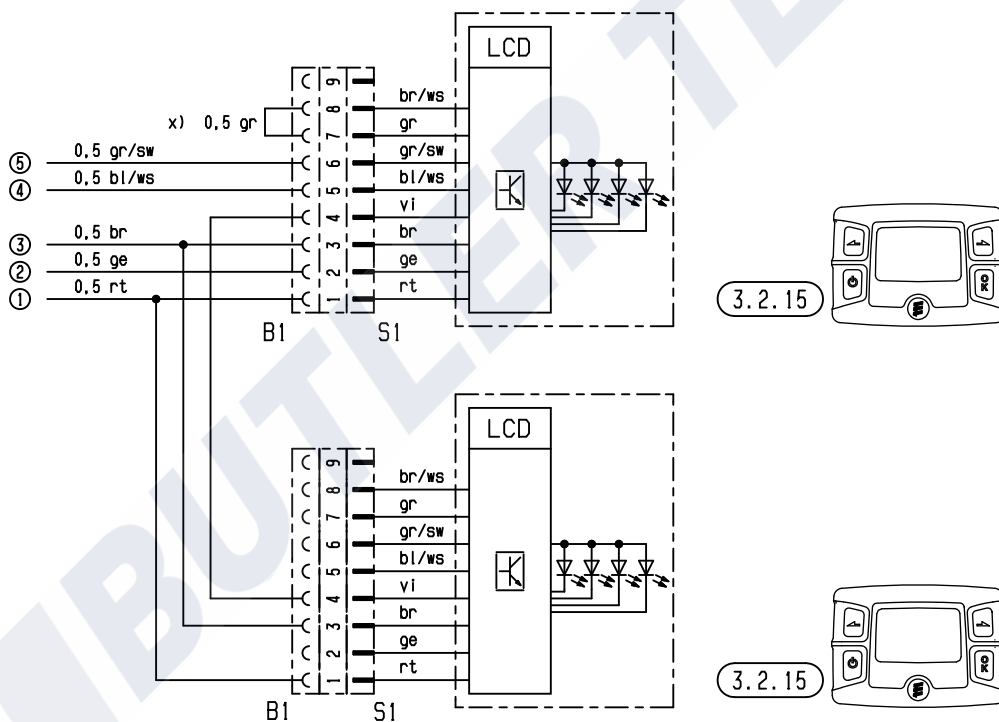

3.2.15

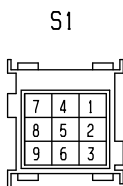
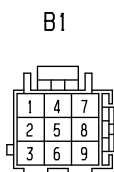



7 Service

Certification

Guaranteed quality from Eberspächer

The high quality of our Eberspächer products is the key to our success. In order to guarantee this success, we have organised all work processes in the company along the lines of quality management (QM). At the same time, we pursue a large number of activities for continuous improvement of product quality in order to keep pace with the constantly increasing customer demands.

All that is necessary to safeguard quality is stipulated in international standards. This quality is to be considered from a total perspective. It refers to products, processes and customer / supplier relationships. Officially certified auditors evaluate the system and the corresponding certification society awards a certificate.

Eberspächer has already undergone the qualification procedures for the following standards:

ISO 9000

Our production process is certified to ISO 9000 (quality management).

QS 9000

In addition to ISO 9000, Eberspächer is always certified to QS 9000 (extended quality management of the American automotive industry of the manufacturers Ford, GM and Chrysler) and VDA 6.1 (extended quality management of the German automotive industry).



ISO 14001

Our production process is certified to ISO 14001 (environment management).



Disposal

Disposal of materials

Used devices, defect components and packaging materials must all be separated in pure grade components so that as far as possible all parts can be disposed of ecologically or recycled. Electric motors, controllers and sensors (e.g. temperature sensors) are classified as "electric scrap".

Dismantling the heater

Dismantle the heater according to the repair steps of the current troubleshooting/repair instructions.

Packaging

The heater packaging can be kept for any possible return deliveries.

7 Service

List of abbreviations

ABG

General type certification

ADR

European agreement on the international transport of dangerous goods by road (ADR)

ADR99

Regulations on dangerous goods in France

EMV

Electromagnetic compatibility

GGVS

Directive on the conveyance of dangerous goods by road (dangerous goods directive road GGVS)

JE Service partner

J. Eberspächer service partner

PME

Bio-diesel as per DIN V 51606

StVZO

German Regulations Authorising the Use of Vehicles for Road Traffic

TRS003

Technical guidelines pertaining to the dangerous goods directive for the road in combination with Appendix B of the ADR



7 Service

Keyword index

A

Accident prevention 4
Adapter cable 16, 17, 20
Assembly drawing 8, 10, 28

C

Certification 53
Combustion air fan 33
Combustion chamber 35
Contents 2, 3
Control and safety features 12
Control diagram 9, 11
Controller lock 15
Controller 31
Customer service program 16, 20

D

Description of functions 12
Detail drawing 8, 10, 28
Diagnosis instrument 16 – 18
Disposal 53
Documentation 5

E

Emergency shut-down 7
Error code 22 – 26
Explosion drawing 28

F

Fan cover 30
Fan speed 34
Fault description 22 – 26
Fault diagnosis 16
Faults 15, 22 – 26
Flame sensor 32
Foreign representatives 54, 55
Fuel pumping quantity 37
Function diagram 9, 11
Function test 5
Function 8 – 12
Fuse 38 – 47

G

Glow plug 31
Guarantee 4

H

Heat exchanger 36
Heating mode 12

I

Icons 4
Initial commissioning 5
Instructions 7
Introduction 2 – 7
ISO 14001 53
ISO 9000 53

L

Liability 4

M

Module clock 16, 19

O

Operation 8 – 12
Overheating sensor 35

P

Parts list 29
Plug filter 30
Plug socket 30
Pre-heating mode 12
Pre-venting 12
Proper use 5

Q

QS 9000 53
Quality 53

R

Radio remote control TP5 17, 22
Range of application 5
Regional representatives 54
Regulations 6, 7
Remote control TP5 22
Repair instructions 29 – 40
Representatives 54, 55

S

Safety features 12
Safety instructions 7
Sectional drawing 8, 10
Sensor 36
Service 53 – 57
Socket 34
Spare parts drawing 28
Spare parts list 29
Speed measurement 33
Statutory regulations 6

T

Technical details 13 – 15
Temperature sensor 35
Testing equipment 15, 16
Troubleshooting 15 – 26

W

Wiring diagram 38 – 52

BUTLER TECHNIK