

## HYDRONIC D5W S

Technical description, installation,  
operation and maintenance instructions.

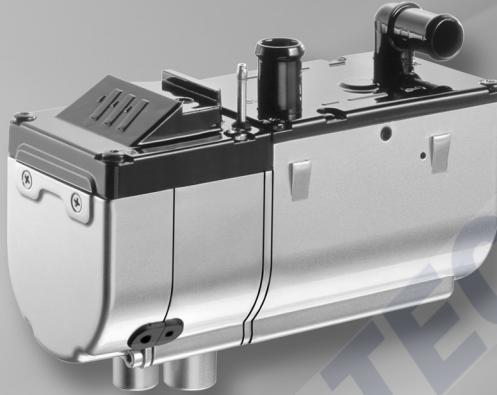

Heater      Order no.

Hydronic B 4 W S – 12 V  
as complete package      20 1866 05 00 00

Hydronic B 4 W S – 12 V      20 1852 05 00 00

Hydronic B 5 W S – 12 V  
as complete package      20 1862 05 00 00

Hydronic B 5 W S – 12 V      20 1819 05 00 00

Heater      Order no.

Hydronic D 4 W S – 12 V  
as complete package      25 2418 05 00 00

Hydronic D 4 W S – 12 V      25 2355 05 00 00

Hydronic D 5 W S – 12 V  
as complete package      25 2386 05 00 00

Hydronic D 5 W S – 12 V      25 2217 05 00 00

**Water heater for diesel and petrol  
operating independently of the engine.**



**Eberspächer**  
A world of comfort

# 1 Introduction

## Contents

Chapter	Title	Contents	Page
1	Introduction	<ul style="list-style-type: none"> <li>• Contents ..... 2</li> <li>• Concept of this manual ..... 3</li> <li>• Special text structure, presentation and picture symbols ..... 4</li> <li>• Important information before starting work ..... 4</li> <li>• Statutory regulations ..... 5, 6</li> <li>• Safety instructions for installation and operation ..... 7</li> <li>• Accident prevention ..... 7</li> </ul>	
2	Product information	<ul style="list-style-type: none"> <li>• Scope of supply petrol / diesel heaters ..... 8, 9</li> <li>• Technical data petrol heaters ..... 10, 11</li> <li>• Technical data diesel heaters ..... 12, 13</li> <li>• Main dimensions ..... 14</li> </ul>	
3	Installation	<ul style="list-style-type: none"> <li>• Installation and location ..... 15</li> <li>• Permissible installation positions ..... 16</li> <li>• Installation and fixing of the heater ..... 17</li> <li>• Installation and fixing of the water pump ..... 17</li> <li>• Mounting the angled water connection ..... 18</li> <li>• Nameplate ..... 18</li> <li>• Connection to the cooling water circuit ..... 19 – 22</li> <li>• Exhaust system ..... 23</li> <li>• Combustion air system ..... 24</li> <li>• Fuel supply petrol / diesel heaters ..... 25 – 29</li> </ul>	
4	Operation and function	<ul style="list-style-type: none"> <li>• Operating instructions / important information for operation ..... 30</li> <li>• Initial commissioning ..... 30</li> <li>• Description of functions ..... 30</li> <li>• Control and safety devices ..... 31</li> </ul>	
5	Electrical system	<ul style="list-style-type: none"> <li>• Heater wiring ..... 32</li> <li>• Parts list for circuit diagram, heater and cable harness ..... 32</li> <li>• Heater circuit diagram ..... 33</li> <li>• Cable harness circuit diagram ..... 34</li> <li>• Control units circuit diagrams ..... 35 – 39</li> </ul>	
6	Troubleshooting Maintenance Service	<ul style="list-style-type: none"> <li>• In case of faults, please check the following points ..... 40</li> <li>• Troubleshooting ..... 40</li> <li>• Maintenance instructions ..... 40</li> <li>• Service ..... 40</li> </ul>	
7	Environment	<ul style="list-style-type: none"> <li>• Certification ..... 41</li> <li>• Disposal ..... 41</li> <li>• EU Declaration of Conformity ..... 41</li> <li>• UKCA Declaration of Conformity ..... 41</li> </ul>	
8	List	<ul style="list-style-type: none"> <li>• List of abbreviations ..... 42</li> </ul>	



# 1 Introduction

## Concept of this manual

This manual aims to support the service company installing the heater and to provide the user with all important information about the heater.

The manual has been divided into 8 chapters to make it easier to find the corresponding information quickly.

### 1 Introduction

Here you will find important introductory information about installation of the heater and about the structure of the manual.

### 2 Product information

Here you will find information about the scope of supply, the technical data and the dimensions of the heater.

### 3 Installation

Here you will find important information and instructions referring to installation of the heater.

### 4 Operation and function

Here you will find information about the operation and function of the heater.

### 5 Electric system

Here you will find information about the electronic system and electronic components of the heater.

### 6 Troubleshooting / maintenance / service

Here you will find information on possible faults, maintenance and technical support.

### 7 Environment

Here you will find information about certification and disposal of the heater together with the EU Declaration of Conformity.

### 8 List

Here you will find the list of abbreviations.

## 1 Introduction

### Special text structure, presentation and picture symbols

This manual uses special text structures and picture symbols to emphasise different contents. Please refer to the examples below for the corresponding meanings and associated actions.

### Special structure and presentations

A dot (•) indicates a list which is started by a heading. If an indented dash (–) follows a dot, this list is subordinate to the dot.

### Picture symbols



#### Regulation!

This picture symbol with the remark "Regulation" refers to a statutory regulation. Failure to comply with this regulation results in expiry of the type permit for the heater and preclusion of any guarantee and liability claims on Eberspächer Climate Control Systems GmbH and its associated companies.



#### Danger!

This picture symbol with the remark "Danger!" refers to the risk of a fatal danger to life and limb. Under certain circumstances, failure to comply with these instructions can result in severe or life-threatening injuries.



#### Caution!

This picture symbol with the remark "Caution!" refers to a dangerous situation for a person and / or the product. Failure to comply with these instructions can result in injuries to people and/or damage to machinery.

#### Please note!

These remarks contain application recommendations and useful tips for installation of the heater.

### Important information before starting work

#### Range of application of the heater

The water heater operating independently of an engine is intended for installation in the following vehicles, depending on its heating output:

- Vehicles of all kinds
- Construction machinery
- Agricultural machinery
- Boats, ships and yachts

#### Please note!

Installation of the heater is **not** permitted in vehicles used for the transport of dangerous goods as per ADR.

#### Purpose of the heater (using the vehicle heat exchanger)

- Pre-heating, de-misting windows
- Heating and keeping the following warm:
  - Driver and working cabs
  - Freight compartments
  - Ship's cabins
  - Passenger and crew compartments
  - Vehicle engines and units

On account of its functional purpose, the heater is **not** permitted for the following applications:

- Long-term continuous operation, e.g. for pre-heating and heating of:
  - Residential rooms
  - Garages
  - Work huts, weekend homes and hunting huts
  - Houseboats, etc.



#### Caution!

#### Safety instructions for application and proper purpose

- The heater must only be used and operated for the range of application stated by the manufacturer in compliance with the "Operating instructions" included with every heater.



# 1 Introduction

## Statutory regulations

The Federal Road Transport Directorate has issued an „EC type approval“ and an „EMC type approval“ for the heater for installation in motor vehicles and with the following official type approval marks, noted on the heater name plate.

Heater type:	ECE type approval mark:
Hydronic	 122 R – 000023 10 R – 041075



## Regulations

Excerpt from ECE regulation No. 122 of the European Parliament and the Council

### General regulations

- **Operating state display**
  - A clearly visible operating display in the user's field of vision must indicate when the heater is switched on and off.

### Regulations concerning installation in the vehicle

- **Scope**
  - Subject to differing stipulations in the following section, combustion heaters must be installed according to the regulations 5.3 of ECE-R122.
  - It is assumed that Class O vehicles with heaters for liquid fuel conform to the regulations 5.3 of ECE-R122.
- **Arrangement of the heater**
  - Parts of the structure and other components near the heater must be protected from excessive heat exposure and possible fuel or oil contamination.
  - The heater must not pose a fire hazard even when it overheats. This requirement is deemed to be fulfilled if adequate clearance is ensured for all parts during installation, sufficient ventilation is provided and fireproof materials or heat shields are used.
  - The heater must not be mounted in the passenger compartment of vehicles in class M<sub>2</sub> and M<sub>3</sub>. However, a heater in a hermetically sealed enclosure which also complies with the aforementioned conditions may be used.
  - The factory nameplate or duplicate must be affixed so that it can still be easily read when the heater is installed in the vehicle.
  - All appropriate precautions must be taken when arranging the heater to minimise the risk of injuries to persons or damage to other property.
- **Fuel supply**
  - The fuel intake connection must not be located in the passenger compartment and must be sealed with a properly

closing lid to prevent any fuel leaks.

- In heaters for liquid fuel where the heater fuel is separate from the vehicle fuel, the type of fuel and intake connection must be clearly identified.
  - A warning sign is to be fixed to the intake connection indicating that the heater must be switched off before refuelling.
- **Exhaust system**
    - The exhaust outlet must be arranged so as to prevent any penetration of exhaust fumes into the vehicle interior through the ventilation system, warm air intakes or open windows.
  - **Combustion air intake**
    - The air for the heater's combustion chamber must not be sucked in from the vehicle's passenger compartment.
    - The air intake must be arranged or protected in such a way that it cannot be blocked by other objects.
  - **Automatic control of the heating system**
    - If the engine fails, the heating system must be automatically switched off and the fuel supply stopped within 5 seconds. The heater may remain in operation if a manual device has already been activated.

### Please note!

The heater is **not** approved for installation in the interior of Class M<sub>1</sub> vehicles (vehicles for passenger transport / cars) and N vehicles (vehicles for the transport of goods).

## 1 Introduction

---

### Statutory regulations

**Please note!**

- Compliance with the statutory regulations, the additional regulations and safety instructions is prerequisite for guarantee and liability claims.  
Failure to comply with the statutory regulations and safety instructions and incorrect repairs even when using original spare parts make the guarantee null and void and preclude any liability for Eberspächer Climate Control Systems GmbH.
- Subsequent installation of this heater must comply with these installation instructions.
- The statutory regulations are binding and must also be observed in countries which do not have any special regulations.
- When the heater is to be installed in vehicles not subject to the German Ordinance for the Registration of Motor Vehicles (StVZO), for example ships, the specially valid regulations and installation instructions for these special applications must be observed.
- Installation of the heater in special vehicles must comply with the regulations applying to such vehicles.
- Other installation requirements are contained in the corresponding sections of this manual.



# 1 Introduction

## Safety instructions for installation and operation



### Danger!

#### Risk of injury, fire and poisoning

- Disconnect the vehicle battery before starting any kind of work.
- Before working on the heater, switch the heater off and let all hot components cool down.
- The heater must not be operated in enclosed rooms, e.g. in the garage or multi-storey car park.



### Caution!

#### Safety instructions for installation and operation

- The heater must only be installed by a JE partner authorised by the manufacturer according to the instructions in this manual and possibly according to special installation recommendations; the same applies to any repairs to be carried out in the case of repairs or guarantee claims.
- Repairs by non-authorized third-parties or with not original spare parts are dangerous and therefore not allowed. They result in expiry of the type permit of the heater; consequently, when installed in motor vehicles they can cause expiry of the vehicle operating licence.
- The following measures are not allowed:
  - Changes to components relevant to the heater.
  - Use of third-party components not approved by Eberspächer Climate Control Systems GmbH.
  - Nonconformities in installation or operation from the statutory regulations, safety instructions or specifications relevant to safe operation as stated in the installation instructions and operating instructions. This applies in particular to the electrical wiring, fuel supply, combustion air system and exhaust system.
- Only original accessories and original spare parts must be used during installation or repairs.
- Only original accessories and spare parts may be used for installation or repairs.
- Only the controls approved by Eberspächer may be used to operate the heater. The use of other controls can result in malfunctions.
- Before the heater is installed again in another vehicle, rinse the heater parts carrying water with clear water.

- When carrying out electric welding on the vehicle, the plus pole cable at the battery should be disconnected and placed at ground to protect the controller.
- Do not operate the heater anywhere where there are readily flammable materials (e.g. dry grass, leaves, paper, etc.) in the area of the exhaust system or where ignitable fumes and dust can form, e.g. near a
  - fuel depot
  - coal depot
  - wood depot
  - grain depots etc.
- The heater must be switched off when refuelling.
- When the heater is mounted in a safety housing etc., the installation compartment of the heater is not a stowage compartment and must be kept clear. In particular fuel canisters, oil cans, spray cans, gas cartridges, fire extinguishers, cleaning rags, items of clothing, paper etc. must not be stored or transported on or next to the heater.
- Defect fuses must only be replaced by fuses with the prescribed rating.
- If fuel leaks from the heater fuel system, arrange for the damage to be repaired immediately by a JE service partner.
- When topping up the coolant, only use the coolant permitted by the vehicle manufacturer, see the vehicle operating manual. Any blending with unpermitted coolant can cause damage to the engine and heater.
- After-running of the heater must not be interrupted prematurely e.g. by pressing the battery disconnecting switch, apart from in the case of an emergency stop.

#### Please note!

Following installation, attach the "Switch off heater before refuelling!" sticker near the tank filler neck.

## Accident prevention

General accident prevention regulations and the corresponding workshop and operation safety instructions are to be observed.

## 2 Product information

### Scope of supply

Quantity / Designation	Order number
------------------------	--------------

#### Complete packages (petrol heaters)

- |  |  |
|--|--|
| 1 Hydronic B 4 W S – 12 V 20 1866 05 00 00 |  |
| 1 Hydronic B 5 W S – 12 V 20 1862 05 00 00 |  |

#### Complete packages (diesel heaters)

- |  |  |
|--|--|
| 1 Hydronic D 4 W S – 12 V 25 2418 05 00 00 |  |
| 1 Hydronic D 5 W S – 12 V 25 2386 05 00 00 |  |

The scope of supply includes:

Picture No.	Designation
-------------	-------------

- |    |                                       |
|----|---------------------------------------|
| 1  | Heater                                |
| 2  | Metering pump                         |
| 3  | Water pump with mounted rubber holder |
| 4  | Mounting angle bracket                |
| 5  | Adapter cable                         |
| 6  | Heater bracket                        |
| 7  | Water hose                            |
| 8  | Flexible exhaust pipe                 |
| 9  | Cable tape                            |
| 10 | Bracket of perforated tape            |
| 11 | Bracket, metering pump                |
| 12 | Pipe, 4 x 1                           |
| 13 | Combustion air hose                   |
| 14 | Hose, 3,5 x 3                         |
| 15 | Pipe, 4 x 1.25                        |
| 16 | Screw M6 x 97                         |
| 17 | Tank withdrawal device                |
| 18 | Cable harness blower                  |
| 19 | Cable harness metering pump           |
| 20 | Combined bracket                      |
| 21 | Exhaust silencer                      |
| 22 | Cable tree, heater                    |

To be ordered separately:

- 1 Control

#### Lead harnesses – see Figure on page 9

- |   |   |
|---|---|
| A | Connection of control units                               |
| B | Vehicle blower control                                    |
| C | Positive supply connection                                |
| D | Negative supply connection                                |
| E | Connection to terminal 85 (1-pin, brown)                  |
| F | Connection to terminal 86 (1-pin, red/black)              |
| G | Diagnosis query (1-pin, blue/white)                       |
| H | Spare connector and seal<br>(required if shortening lead) |
| I | Positive power supply connection - blower relay           |

Quantity / Designation	Order number
------------------------	--------------

#### Petrol heaters

- |  |  |
|--|--|
| 1 Hydronic B 4 W S – 12 V 20 1852 05 00 00 |  |
| 1 Hydronic B 5 W S – 12 V 20 1819 05 00 00 |  |

#### Diesel heaters

- |  |  |
|--|--|
| 1 Hydronic D 4 W S – 12 V 25 2355 05 00 00 |  |
| 1 Hydronic D 5 W S – 12 V 25 2217 05 00 00 |  |

The scope of supply includes:

Picture No.	Designation
-------------	-------------

- |   |                                       |
|---|---------------------------------------|
| 1 | Heater                                |
| 2 | Metering pump                         |
| 3 | Water pump with mounted rubber holder |
| 4 | Mounting angle bracket                |
| 5 | Adapter cable                         |

To be ordered separately:

- 1 Control  
– Parts for the installation

Parts which are absolutely necessary for the installation, see also Figure on page 9.

Picture No.	Designation
-------------	-------------

- |    |                            |
|----|----------------------------|
| 6  | Heater bracket             |
| 7  | Water hose                 |
| 8  | Flexible exhaust pipe      |
| 10 | Bracket of perforated tape |
| 11 | Bracket, metering pump     |
| 12 | Pipe, 4 x 1                |
| 13 | Combustion air hose        |
| 14 | Hose, 3,5 x 3              |
| 15 | Pipe, 4 x 1.25             |
| 16 | Screw M6 x 97              |
| 17 | Tank withdrawal device     |
| 18 | Cable harness blower       |
| 19 | Cable harness dosing pump  |
| 20 | Combined bracket           |
| 21 | Exhaust silencer           |
| 22 | Cable tree, heater         |

**Please note!**

- Parts without picture number are small parts and packed in a bag.
- Order No. for controls and parts for the installation, see price list, spare parts list and product overview.





## 2 Product information

Technical data / petrol heater		B 4 W S	
Heating medium		Water, cooling fluid	
Control of the heat flow		Large	Small
Heat flow (watt)		4300	1500
Fuel consumption (l/h)		0.6	0.2
Mean electr. power (watt)		in operation	35
		at start	110
		after-running	8
Electr. power of water pump		<15 watt	
Rated voltage		12 volt	
Operating range			
<ul style="list-style-type: none"> <li>Lower voltage limit: An undervoltage protector installed in the control box switches off the heater when the voltage limit is reached.</li> </ul>		10.2 volt	
<ul style="list-style-type: none"> <li>Upper voltage limit: An overvoltage protector installed in the control box switches off the heater when the voltage limit is reached.</li> </ul>		16 volt	
Tolerable operating pressure		up to 2.5 bar overpressure	
Flow rate of the water pump at 0.1 bar		850 l/h	
Minimum water flow rate of the heater		250 l/h	
Fuel – see also “fuel quality petrol heaters” page 29		Commercially available petrol (DIN EN 228)	
Tolerable operating temperature			
	Heater	Operation	Not running
	Control unit	-40 °C to +80 °C	-40 °C to +125 °C
	Metering pump	-40 °C to +80 °C	-40 °C to +105 °C
Interference suppression class		-40 °C to +20 °C	
		5	
Weight		DIN 57879 / Part1 VDE 0879	
Without cooling fluid and add on pieces		approx. 2.3 kg	
With dosing pump and water pump		approx. 2.9 kg	



### Caution!

#### Safety instructions for technical data!

Failure to comply with the technical data can result in malfunctions.

#### Please note!

Provided no limit values are given, the technical data listed is subject to the tolerances usually applicable to heaters of  $\pm 10\%$  for nominal voltage, ambient temperature 20 °C and reference altitude Esslingen.



## 2 Product information

Technical data / petrol heater		B 5 W S	
Heating medium		Water, cooling fluid	
Control of the heat flow		Large	Small
Heat flow (watt)		5000	1500
Fuel consumption (l/h)		0.69	0.2
Mean electr. power (watt)		in operation	37
		at start	110
		after-running	8
Electr. power of water pump		<15 watt	
Rated voltage		12 volt	
Operating range			
<ul style="list-style-type: none"> <li>Lower voltage limit: An undervoltage protector installed in the control box switches off the heater when the voltage limit is reached.</li> </ul>		10.2 volt	
<ul style="list-style-type: none"> <li>Upper voltage limit: An overvoltage protector installed in the control box switches off the heater when the voltage limit is reached.</li> </ul>		16 volt	
Tolerable operating pressure		up to 2.5 bar overpressure	
Flow rate of the water pump at 0.1 bar		850 l/h	
Minimum water flow rate of the heater		250 l/h	
Fuel – see also “fuel quality petrol heaters” page 29		Commercially available petrol (DIN EN 228)	
Tolerable operating temperature			
		Operation	Not running
	Heater		
	Control unit	-40 °C to +80 °C	-40 °C to +125 °C
	Metering pump	-40 °C to +80 °C	-40 °C to +105 °C
		-40 °C to +20 °C	-40 °C to +105 °C
Interference suppression class		5	
Weight		DIN 57879 / Part1 VDE 0879	
Without cooling fluid and add on pieces		approx. 2.3 kg	
With dosing pump and water pump		approx. 2.9 kg	



### Caution!

#### Safety instructions for technical data!

Failure to comply with the technical data can result in malfunctions.

#### Please note!

Provided no limit values are given, the technical data listed is subject to the tolerances usually applicable to heaters of  $\pm 10\%$  for nominal voltage, ambient temperature 20 °C and reference altitude Esslingen.

## 2 Product information

Technical data / diesel heater		D 4 W S	
Heating medium		Water, cooling fluid	
Control of the heat flow		Large	Small
Heat flow (watt)		4300	2400
Fuel consumption (l/h)		0.53	0.27
Mean electr. power (watt)		in operation	35
		at start	110
		after-running	8
Electr. power of water pump		<15 watt	
Rated voltage		12 volt	
Operating range			
<ul style="list-style-type: none"> <li>Lower voltage limit: An undervoltage protector installed in the control box switches off the heater when the voltage limit is reached.</li> </ul>		10.2 volt	
<ul style="list-style-type: none"> <li>Upper voltage limit: An overvoltage protector installed in the control box switches off the heater when the voltage limit is reached.</li> </ul>		16 volt	
Tolerable operating pressure		up to 2.5 bar overpressure	
Flow rate of the water pump at 0.1 bar		850 l/h	
Minimum water flow rate of the heater		250 l/h	
Fuel – see also “fuel quality petrol heaters” page 29		Commercially available diesel (DIN EN 590)	
Tolerable operating temperature			
		Operation	Not running
Heater			
Control unit		-40 °C to +80 °C	-40 °C to +125 °C
Metering pump		-40 °C to +80 °C	-40 °C to +105 °C
Interference suppression class		-40 °C to +80 °C	-40 °C to +105 °C
		5	
Weight		DIN 57879 / Part1 VDE 0879	
Without cooling fluid and add on pieces		approx. 2.3 kg	
With dosing pump and water pump		approx. 2.9 kg	



### Caution!

#### Safety instructions for technical data!

Failure to comply with the technical data can result in malfunctions.

#### Please note!

Provided no limit values are given, the technical data listed is subject to the tolerances usually applicable to heaters of ±10% for nominal voltage, ambient temperature 20 °C and reference altitude Esslingen.



## 2 Product information

Technical data / diesel heater		D 5 W S	
Heating medium		Water, cooling fluid	
Control of the heat flow		Large	Small
Heat flow (watt)		5000	2400
Fuel consumption (l/h)		0.62	0.27
Mean electr. power (watt)		in operation	37
		at start	110
		after-running	8
Electr. power of water pump		<15 watt	
Rated voltage		12 volt	
Operating range			
<ul style="list-style-type: none"> <li>Lower voltage limit: An undervoltage protector installed in the control box switches off the heater when the voltage limit is reached.</li> </ul>		10.2 volt	
<ul style="list-style-type: none"> <li>Upper voltage limit: An overvoltage protector installed in the control box switches off the heater when the voltage limit is reached.</li> </ul>		16 volt	
Tolerable operating pressure		up to 2.5 bar overpressure	
Flow rate of the water pump at 0.1 bar		850 l/h	
Minimum water flow rate of the heater		250 l/h	
Fuel – see also “fuel quality petrol heaters” page 29		Commercially available diesel (DIN EN 228)	
Tolerable operating temperature			
		Operation	Not running
	Heater		
	Control unit	-40 °C to +80 °C	-40 °C to +125 °C
	Metering pump	-40 °C to +80 °C	-40 °C to +105 °C
Interference suppression class		-40 °C to +80 °C	
		5	
Weight		DIN 57879 / Part1 VDE 0879	
Without cooling fluid and add on pieces		approx. 2.3 kg	
With dosing pump and water pump		approx. 2.9 kg	



### Caution!

#### Safety instructions for technical data!

Failure to comply with the technical data can result in malfunctions.

#### Please note!

Provided no limit values are given, the technical data listed is subject to the tolerances usually applicable to heaters of  $\pm 10\%$  for nominal voltage, ambient temperature 20 °C and reference altitude Esslingen.

## 2 Product information

### Main dimensions heater

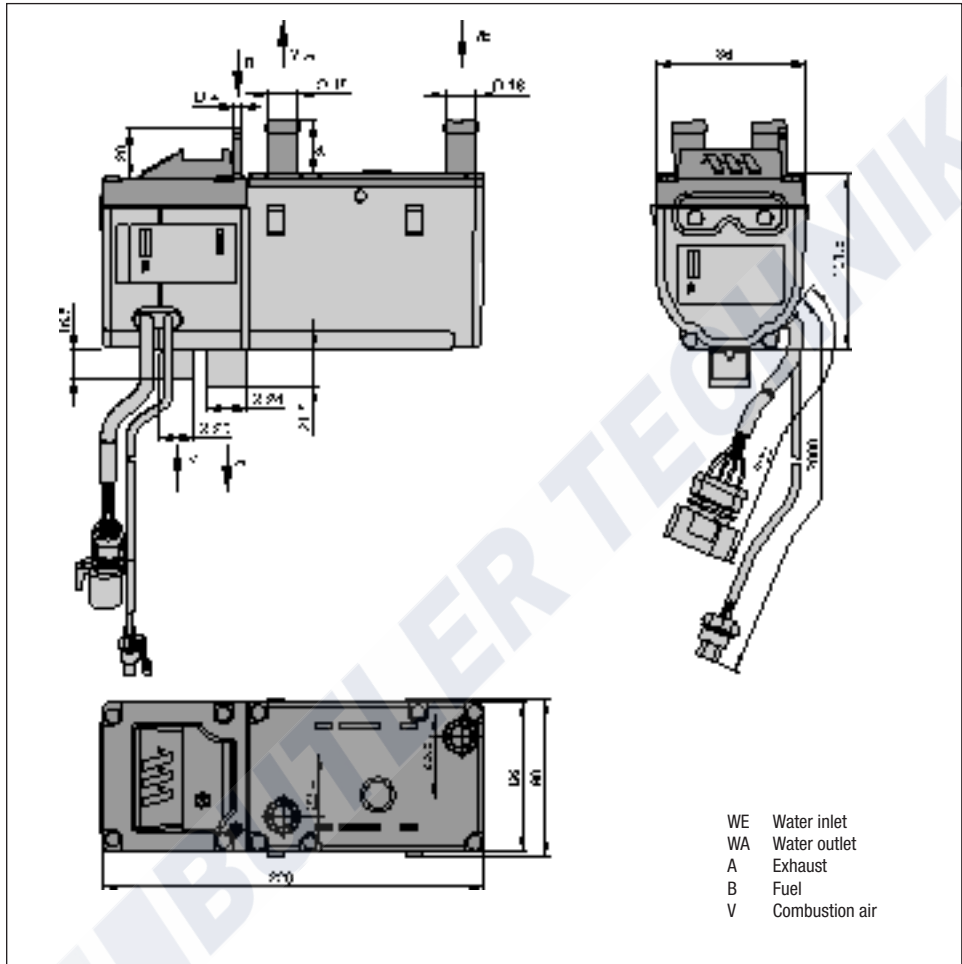

### Main dimensions water pump

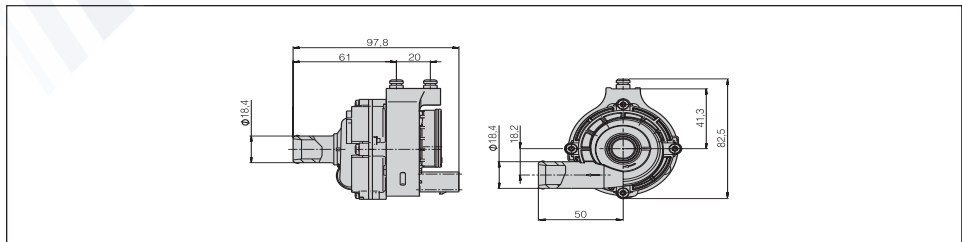



### 3 Installation

#### Installation location

The installation location for the heater is the engine compartment. The heater must be mounted below the min. cooling water level (compensation tank, cooler, vehicle heat exchanger) for automatic venting of the heat exchanger of the heater and the water pump.

**Please note!**

- The regulations and safety instructions to be observed for this chapter are stated on page 4 – 7.
- The installation suggestions made in the installation instructions are examples. Other installation locations are possible if they correspond to the installation requirements stated in these installation instructions.
- Other installation information (e.g. for boats and ships) is available from the manufacturer on request.
- Please take note of the installation locations together with the operating and storage temperatures.  
Ensure an adequate distance from hot vehicle parts.

#### Installation example heater in a car

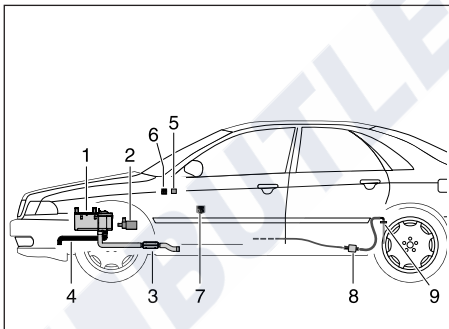

- 1 Heater
- 2 Water pump
- 3 Exhaust pipe with exhaust silencer
- 4 Combustion air intake silencer
- 5 Fan relay
- 6 Fuse bracket
- 7 Control unit
- 8 Metering pump
- 9 Rising pipe

#### Installation example heater in a delivery van

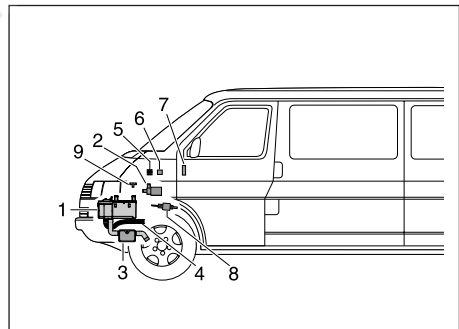

- 1 Heater
- 2 Water pump
- 3 Exhaust pipe with exhaust silencer
- 4 Combustion air hose
- 5 Fuse holder
- 6 Fan relay
- 7 Control unit
- 8 Metering pump
- 9 T-piece for fuel

### 3 Installation

#### Permissible installation positions – heater

The heater should preferably be installed in the normal position, horizontal with the exhaust connection down to the bottom. Depending on the installation conditions, the heater can also be mounted in the permitted swivel range, see diagram.

When the heater is operating, the shown normal or maximum installation positions can be varied briefly by up to  $+15^\circ$  in all directions. Such deviations caused by the inclined position of the vehicle do not impair the heater functions in any way.

#### Heater in normal position with permitted swivel range

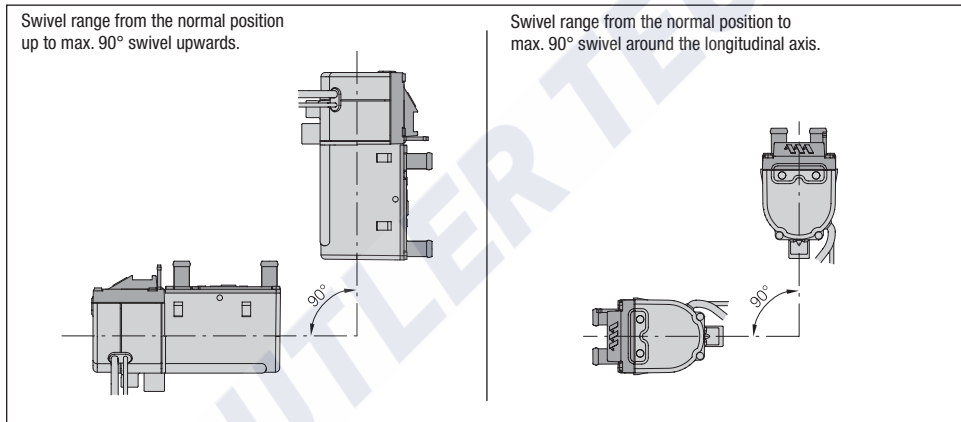

#### Permissible installation positions – water pump

The water pump can be installed in any position.

**Please note!**

- The water inlet must be designed so that it is always completely filled with water (the water pump is not self-priming).
- Installing the water pump with the pump head facing downwards is not good for automatic venting.





### 3 Installation

#### Installation and fixing of the heater

Position the heater in the holding clips of the heater bracket and fasten with fastening screw, M6 x 97 (torque 6<sup>0.5</sup>Nm). Mount the heater bracket in a suitable position in the engine compartment, possibly using anti-vibration pads if necessary.

**Please note!**

Depending on the installation space available, the heater can be moved sideways in the bracket and screwed in one of the two fastening threads.

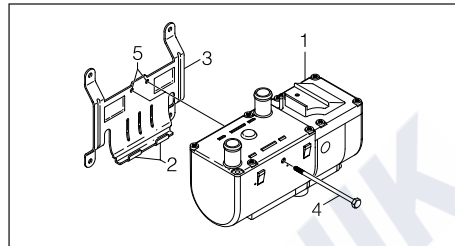

- 1 Heater
- 2 Bracket clips
- 3 Bracket holder
- 4 Fastening screw
- 5 Fastening thread

#### Installation and fixing of the water pump

Use a hexagon screw size M6 x 12 and a hexagon nut size M6 to fix the mounting angle bracket in a suitable position within the vehicle.

The fix the water pump to the mounting angle bracket using both retaining clips.

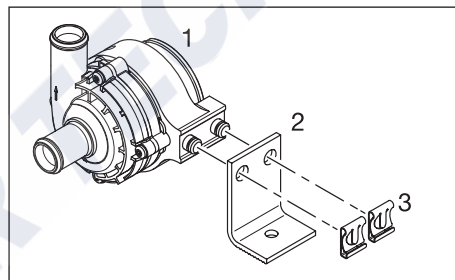

- 1 Water pump
- 2 Mounting angle bracket
- 3 Retaining clips

#### Possible installation positions of the mounting angle bracket

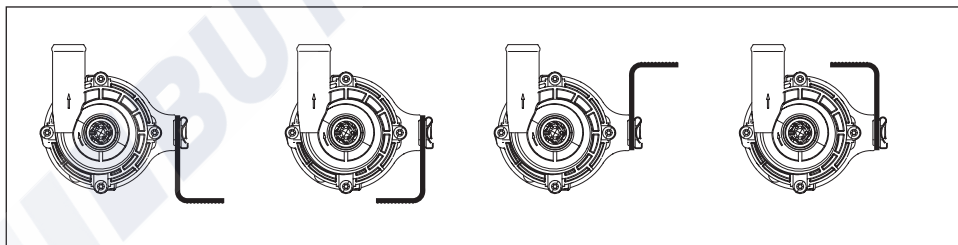

### 3 Installation

#### Mounting the angled water connection

The heater is supplied with a straight water connection. Depending on the installation conditions, it may be necessary to mount an angled water connection.

- Unscrew the fastening screws on the cover and remove the cover.
- Press the straight water connection down.
- Loosen the indented ring and remove the O-ring seal.
- Pull the water connection out of the cover.
- Insert the angled water connection into the cover, insert the new O-ring seal in the provided groove and grease lightly.
- Mount the indented ring to the angled water connection, turn the water connection according to the installation position and insert in the toothed rim of the cover.
- Screw the cover to the housing again using 4 screws, torque 4 Nm.

If the previous screw opening is covered by the angled water connection, the neighbouring screw hole will have to be used instead.

Please proceed as follows:

- Cut a thread in the bore of the aluminium housing: to do so, screw a tapping screw into the bore and unscrew it again.
- Place the cover on the housing and screw in all four screws – torque 4.5 Nm.

**Please note!**

The thread must be cut before mounting the cover.

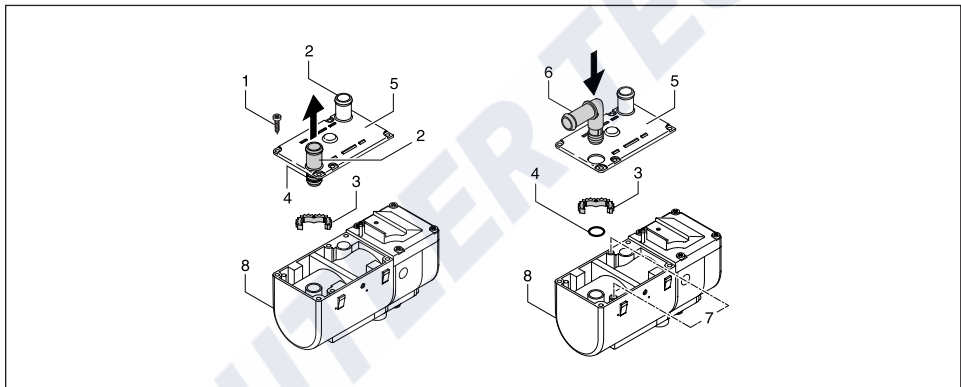

- 1 Fastening screws
- 2 Straight connection
- 3 Indented ring
- 4 O-ring

- 5 Cover
- 6 Angled connection
- 7 Bore holes
- 8 Heater

#### Nameplate

The nameplate is fastened to the front of the heater. The second nameplate (duplicate) is included in the scope of supply of the heater.

If required, the duplicate nameplate can be adhered in a clearly visible position on the heater or near to the heater.

**Please note!**

The registration and safety instructions to be observed for this chapter are stated on page 5.

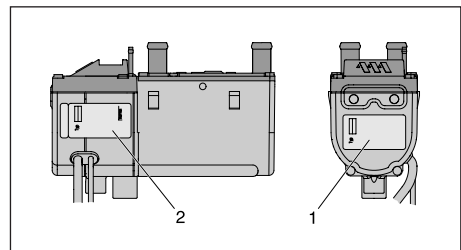

- 1 Original nameplate
- 2 2<sup>nd</sup> nameplate (duplicate)



### 3 Installation

#### Connection to the cooling water circuit

The heater is connected to the cooling water circuit in the water feed pipe from the vehicle engine to the heat exchanger. There are four possible alternative installations here.

The alternatives are described on pages 20 – 22.



#### **Danger!** **f injuries and burns!**

It is possible for the coolant and components of the coolant circuit to get very hot.

- Parts conveying water must be routed and fastened in such a way that they pose no temperature risk to man, animals or material sensitive to temperature from radiation / direct contact.
- Before working on the coolant circuit, switch the heater off and wait until all components have cooled down completely, if necessary where safety gloves.

#### **Please note!**

- When installing the heater and the water pump, please note the direction of flow of the coolant circuit.
- Fill the heater and water hose with anti-freeze before connecting to the cooling water circuit.
- Route the water hoses without any kinks, and in a rising position if possible.
- When routing the water pipes, observe a sufficient clearance to hot vehicle parts.
- Protect all water hoses / water pipes from chafing and from extreme temperatures.
- Secure all hose connections with hose clips (tightening torque =  $3^{+0.5}$  Nm).
- After the vehicle has been operating for 2 hours or travelled 100 km, tighten the hose clips again.
- The minimum water flow rate is only guaranteed if the temperature difference of the heating medium does not exceed 10 K between water inlet and water outlet during heating.
- Only overpressure valves with an opening pressure of min. 0.4 – max. 2 bar may be used in the coolant circuit.
- The cooling water must contain at least 10 % antifreeze all year round as corrosion protection.
- During cold periods the cooling water must contain sufficient antifreeze.
- Before commissioning the heater or after changing the cooling liquid, the whole coolant circuit including heater must be vented free of bubbles according to the instructions issued by the vehicle manufacturer.
- Only top up with antifreeze approved by the vehicle manufacturer.

### 3 Installation

#### Connection to the cooling water circuit

##### Integrate the heater in the water feed pipe from the vehicle engine to the heat exchanger "inline connection"

Disconnect the water feed pipe from the vehicle engine to the vehicle heat exchanger. Connect up the heater with connection pieces and water hoses to the water feed pipe.

Route and connect a water hose from the pressure connection of the water pump to the water intake connection of the heater.

##### Heating characteristics

When the heater is switched on, the heat flows through the vehicle heat exchanger and the vehicle engine.

Once the cooling water has reached a temperature of approx. 30 °C, depending on the selected fan setting the vehicle fan is switched on and the heat is also conveyed to the passenger compartment.

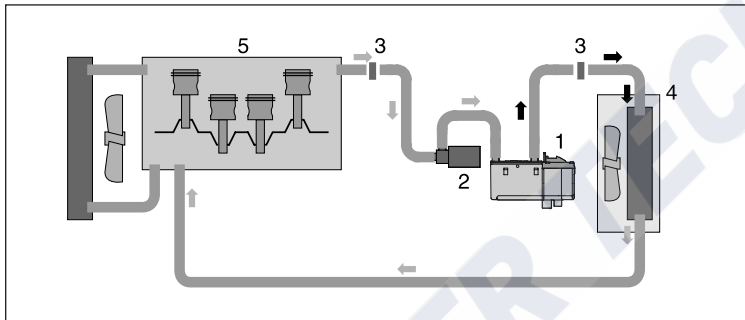

- 1 Heater
- 2 Water pump
- 3 Connection piece
- 4 Heat exchanger
- 5 Vehicle engine

##### Integrate the heater, water pump and non-return valve in the cooling water circuit

Disconnect the water feed pipe from the vehicle engine to the vehicle heat exchanger and insert the non-return valve.

Connect the heater and the water pump to the non-return valve with the water hoses.

Route and connect a water hose from the pressure connection of the water pump to the water intake connection of the heater.

##### Heating characteristics

When the heater is switched on, the heat flows through the vehicle heat exchanger only to the vehicle engine.

Once the cooling water has reached a temperature of approx. 30 °C, depending on the selected fan setting the vehicle fan is switched on and the heat is also conveyed to the passenger compartment.

##### Advantage compared to "inline connection" cooling water circuit

No loss of efficiency in the vehicle heating when the heater is switched off.

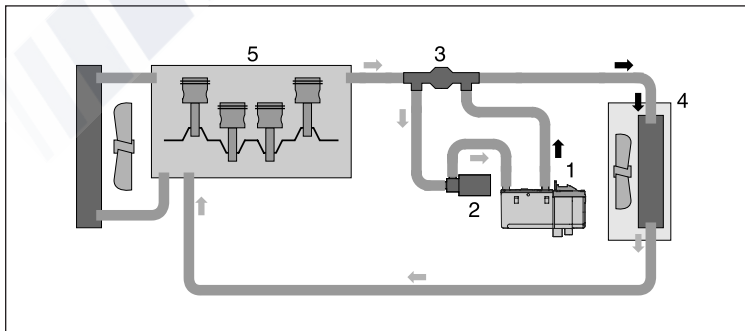

##### Please note!

Non-return valve must be ordered separately, see product overview for Order No.

- 1 Heater
- 2 Water pump
- 3 Non-return valve
- 4 Heat exchanger
- 5 Vehicle engine



### 3 Installation

#### Connection to the cooling water circuit

**Integrate the heater, water pump, non-return valve, thermostat and T-piece in the cooling water circuit.**

Disconnect the water feed pipe from the vehicle engine to the vehicle heat exchanger and insert the non-return valve.

Disconnect the water return pipe from the heat exchanger to the vehicle engine and insert the T-piece.

Connect the heater and the water pump to the thermostat, non-return valve and T-piece using water hoses, as shown in the diagram.

#### Heating characteristics

##### Small coolant circuit

Fast heating of the passenger compartment. Initially the heat produced by the heater is only conveyed to the heat exchanger up to a cooling water temperature of approx. 70 °C. This heats the passenger compartment up quickly.

##### Large cooling water circuit

If the cooling water temperature continues to increase, the thermostat slowly changes over to the large circuit (full change-over at approx. 75 °C). This heats the passenger compartment up and also allows for engine pre-heating.

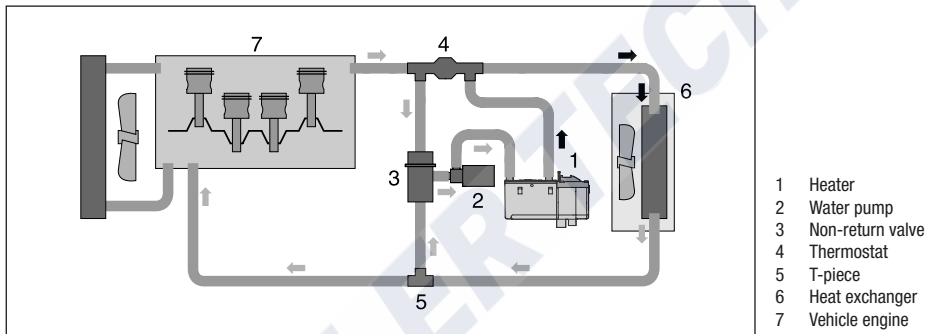

- 1 Heater
- 2 Water pump
- 3 Non-return valve
- 4 Thermostat
- 5 T-piece
- 6 Heat exchanger
- 7 Vehicle engine

**Please note!**

The thermostat, non-return valve and T-piece must be ordered separately, see product overview for Order No.

#### Thermostat functions

Cooling water temperature <70 °C – small coolant circuit:

- Connection no. 1 – open to the heater
- Connection no. 2 – open to the T-piece
- Connection no. 3 – closed to the non-return valve

Cooling water temperature >75 °C – large coolant circuit:

- Connection no. 1 – open (to the heater)
- Connection no. 2 – closed (to the T-piece)
- Connection no. 3 – open (to the non-return valve)

**Please note!**

Integrate the thermostat into the water circuit with connections (1), (2) and (3) as shown in the diagram.

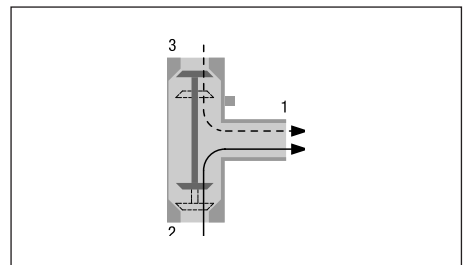

- 1 Connection to the heater
- 2 Connection to the T-piece
- 3 Connection to the non-return valve

### 3 Installation

#### Connection to the coolant circuit

**Integrate the heater, water pump and combination valve with thermostat function in the cooling water circuit**

#### Combination valve with 5 connections

Order no. 25 2014 80 72 00

If the water feed pipe and water return pipe from the vehicle engine to the heat exchanger are installed separately, the combination valve with 5 connections and an additional T-piece has to be used.

#### Combination valve with 6 connections

Order no. 25 2014 80 62 00

If the water feed pipe and water return pipe from the vehicle engine to the heat exchanger are installed in parallel, the combination valve with 6 connections (without T-piece) can be used.

#### Heating characteristics in parking heater mode

##### Small cooling water circuit with heat discharge in the vehicle's interior.

Initially, up to a cooling water temperature of approx 67 °C, the heat from the heater is only fed to the heat exchanger - inside of the vehicle heats up fast.

##### Small cooling water circuit with heat discharge at the vehicle's engine.

From a cooling water temperature of around 67 °C, part of the heater's heat is also fed to the vehicle's engine.

This slowly heats the engine circuit, without causing the „small cooling water circuit“ for heating the vehicle's interior to rapidly cool down.

#### Heating characteristics in independent heater mode

##### Large cooling water circuit

When the vehicle's engine is running the heat is uniformly distributed to the heat exchanger and vehicle engine - further shortening of the warm-up phase and heating up of the inside of the vehicle.

#### Install combination valve with 5 connections

Disconnect the water feed pipe from the vehicle engine to the vehicle heat exchanger and insert the combination valve.

Disconnect the water return pipe from the heat exchanger to the vehicle engine and insert the T-piece.

Connect the heater to the combination valve and T-piece with the water hoses, as shown in the drawing.

#### Install combination valve with 6 connections

Disconnect the water feed pipe and the water return pipe from the vehicle engine to the vehicle heat exchanger and insert the combination valve.

Connect the heater to the combination valve with the water hoses, as shown in the drawing.

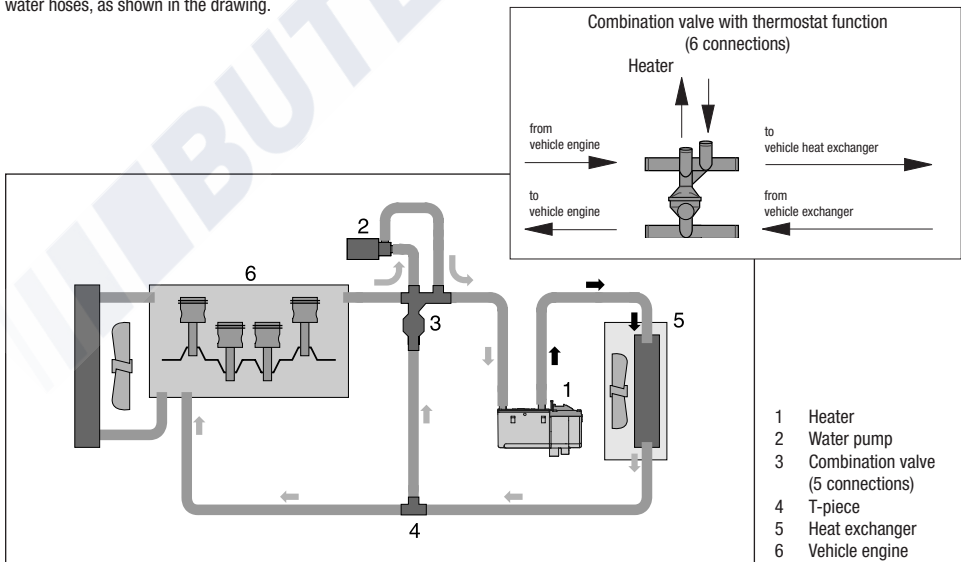



### 3 Installation

#### Exhaust system

(Exhaust diagram see page 24)

#### Mounting the exhaust system

A flexible exhaust pipe, inner  $\varnothing$  24 mm and an exhaust silencer are absolutely necessary for the installation.

The flexible exhaust pipe can be shortened to 20 cm or lengthened to max. 2 m (including exhaust silencer) according to the installation conditions.

Fasten the exhaust silencer to a suitable position in the vehicle. Route the flexible exhaust pipe from the heater to the exhaust silencer and fasten with pipe clips (tightening torque =  $7^{+0.5}$  Nm). Use a pipe clip to fix a short exhaust pipe end (with end sleeve) to the exhaust silencer (tightening torque =  $7^{+0.5}$  Nm).



#### Caution!

#### Safety instructions!

The whole exhaust system gets very hot during and immediately after the heater has been working in the heating mode. This is why the exhaust system must be routed according to these installation instructions.

- The exhaust outlet must end in the open air.
- The exhaust pipe must not protrude beyond the lateral limits of the vehicle.
- Install the exhaust pipe sloping slightly downwards. If necessary, make a drain hole approx.  $\varnothing$  5 mm at the lowest point to drain off condensation.
- Important functional parts of the vehicle must not be impaired (keep sufficient clearance).
- Mount the exhaust pipe with sufficient clearance to heat-sensitive parts. Pay particular attention to fuel pipes (plastic or metal), electrical cables and brake hoses etc.!
- Exhaust pipes must be fastened safely (recommended clearance of 50 cm) to avoid damage from vibrations.
- Route the exhaust system so that the emitted fumes are not sucked in with the combustion air.
- The mouth of the exhaust pipe must not get clogged by dirt and snow.
- The mouth of the exhaust pipe must not point in the direction of travel.
- Always fasten the exhaust silencer to the vehicle.



#### Danger!

#### Risk of injuries and burns!

Every type of combustion produces high temperatures and toxic exhaust fumes. This is the reason why the exhaust system must be installed according to these instructions.

- Do not perform any work on the exhaust system while the heater is working.
- Before working on the exhaust system, first switch the heater off and wait until all parts have cooled down completely, wear safety gloves if necessary.
- Do not inhale exhaust fumes.

#### Please note!

- Comply with the regulations and safety instructions for this chapter on page 4 – 7.
- If a silencer is fitted, the exhaust end pipe must be much shorter than the flexible exhaust pipe between the heater and the exhaust silencer.
- To prevent contact erosion, the clips used to fix the exhaust pipe must be made of stainless steel. The order No. for the stainless steel fixing clips is given in the product overview.

### 3 Installation

#### Combustion air system

##### Mounting the combustion air system

The heater is mounted in the engine compartment, as described in these instructions.

If the intake connection for combustion air is in a position where the combustion air can be expected to be no warmer than 25°C and whether neither splashed water nor dust / dirt are expected, then no combustion air hose is required.

Otherwise a flexible combustion hose must be mounted with an inner Ø 20 mm and up to 1.5 m long, to ensure that the intake of combustion air comes from an area which complies with the above conditions.

After completing all work, push an end sleeve over the intake silencer / flexible pipe.

Use a hose clip to fix the combustion air hose to the heater (tightening torque 3<sup>+0.5</sup> Nm).

**Please note!**

Comply with the regulations and safety instructions for this chapter on page 4 – 7.



**Caution!**

**Safety instructions for the combustion air system**

- The combustion air opening must be free at all times.
- Position the combustion air intake to be sure that exhaust fumes cannot be sucked in with the combustion air.
- Do not point the combustion air intake against the vehicle's airstream.
- The combustion air intake must not get clogged with dirt and snow.
- Install the combustion air intake system sloping slightly downwards. If necessary, make a drain hole approx. Ø 5 mm at the lowest point to drain off condensation.

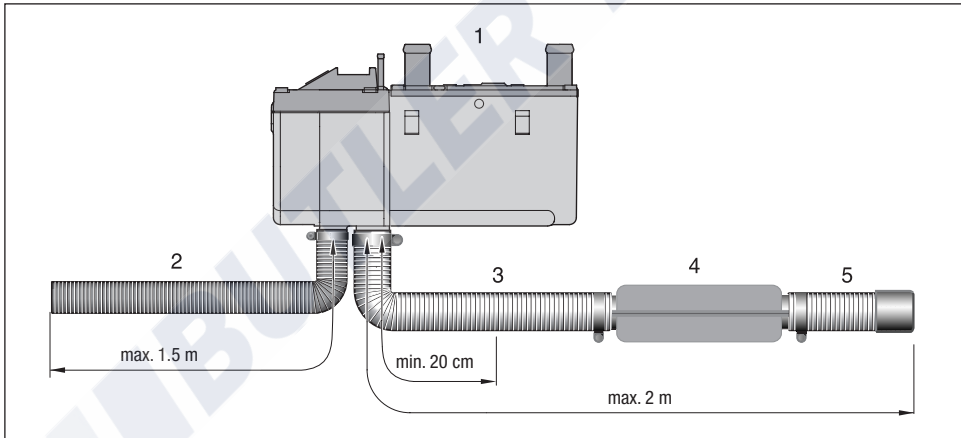

- 1 Heater
- 2 Combustion air pipe
- 3 Exhaust pipe
- 4 Exhaust silencer
- 5 Exhaust end pipe with endsleeve





### 3 Installation

#### Fuel supply

##### Mounting the metering pump, routing the fuel pipes and mounting the fuel tank

The following safety instructions must be observed when mounting the metering pump, routing the fuel pipes and mounting the fuel tank.

Deviations from the instructions stated here are not allowed. Failure to comply can result in malfunctions.



#### Danger!

##### Risk of fire, explosion, poisoning and injuries!

Caution when handling fuel.

- Switch off the vehicle engine and heater before refuelling and before working on the fuel supply.
- No naked lights when handling fuel.
- Do not smoke.
- Do not inhale fuel vapours.
- Avoid any contact with the skin.



#### Caution!

##### Safety instructions for routing the fuel pipes!

- Only use a sharp knife to cut off fuel hoses and pipes. Interfaces must not be crushed and must be free of burrs.
- The fuel pipe from the metering pump to the heater should be routed at a continuous rise.
- Fuel pipes must be fastened safely to avoid any damage and / or noise production from vibrations (recommended clearance of approx. 50 cm).
- Fuel pipes must be protected from any mechanical damage.
- Use hose clips to secure all hose connections in the fuel supply (tightening torque  $1^{+0.2}$  Nm).
- Route the fuel pipes so that any distortion of the

vehicle, engine movements etc. cannot have any lasting effect on the service life.

- Parts carrying fuel must be protected from interfering heat.
- Never route or fasten the fuel pipes to the heater or vehicle exhaust system. When the systems cross, always ensure there is a sufficient heat clearance. If necessary, install heat deflection plates.
- Dripping or evaporating fuel must never be allowed to collect on hot parts or ignite on electric systems.
- When connecting fuel pipes with a fuel hose, always mount the fuel pipes in a butt joint to prevent any bubbles from forming.

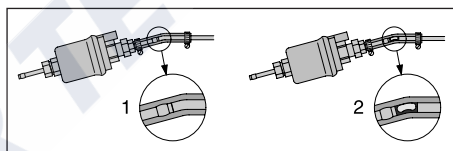

- 1 Correct connection
- 2 Incorrect connection – bubble formation



#### Caution!

##### Safety instructions for fuel pipes and fuel tanks in buses and coaches

- In buses and coaches, fuel pipes and fuel tanks must not be routed through the passenger compartment or driver's cab.
- Fuel tanks in buses and coaches must be positioned in such a way that the exits are not in direct danger from a possible fire.

#### Please note!

Comply with the regulations and safety instructions for this chapter on page 4 – 7.

### 3 Installation

#### Fuel supply

Fuel feed point with T-piece from the fuel supply line from the tank fitting to the vehicle engine

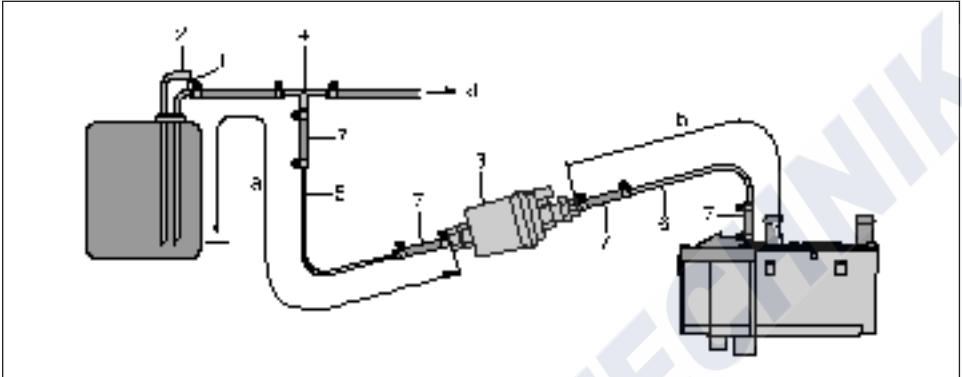

- 1 Fuel feed pipe from tank connection – insert T-piece before the fuel pump in the fuel feed pipe.
  - 2 Fuel return pipe to the tank connection
  - 3 Metering pump
  - 4 T-piece
  - 5 Fuel pipe, 4 x 1 (di = Ø 2 mm)
  - 6\* Fuel pipe, 4 x 1.25 (di = Ø 1.5 mm)
  - 7 Fuel hose, 3.5 x 3 (di = Ø 3.5 mm), approx. 50 mm long
  - 8 To the engine, mechanical fuel or injection pump.
- \* If necessary, a fuel pipe 4 x 1 (di = Ø 2 mm) can be used for diesel heaters instead of the fuel pipe 4 x 1.25 (di = Ø 1.5 mm), Item (6).  
The details regarding the pipe lengths remain unchanged.  
The fuel pipe, 4 x 1 must be ordered separately, please refer to the spare parts list or product overview for the Order No.

#### Possible pipe lengths

Intake side Pressure side

a = max. 2 m b = max. 4 m for petrol

b = max. 6 m for diesel

**Please note!**

Item (4) is not included in the scope of supply "installation kit".  
Order no. see product overview.

#### Installation position of the T-piece

Use the installation positions shown in the diagram when inserting a T-piece.

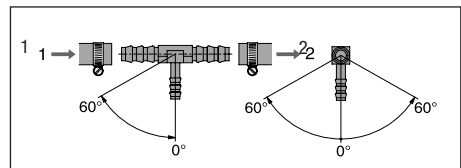

- 1 Direction of flow from the fuel tank
- 2 Direction of flow to the vehicle engine



### 3 Installation

#### Fuel supply

Fuel feed point with tank connection –  
ascending pipe, integrated in the tank fitting

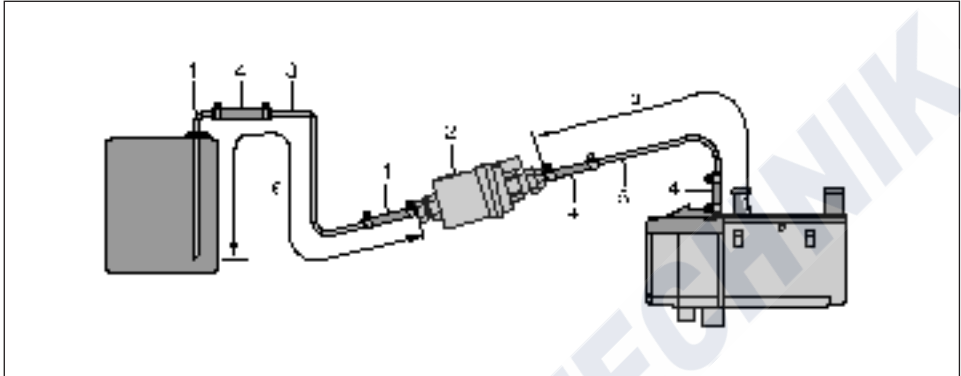

- 1 Tank connection for tank fitting –  
di = Ø 2 mm, da = Ø 4 mm
- 2 Metering pump
- 3 Fuel hose, 4 x 1 (di = Ø 2 mm)
- 4 Fuel hose, 3.5 x 3 (di = Ø 3.5 mm),  
approx. 50 mm long
- 5\* Fuel pipe, 4 x 1.25 (di = Ø 1.5 mm)

**Intake side**  
a = max. 2 m

**Pressure side**  
b = max. 4 m for petrol  
b = max. 6 m for diesel

- \* If necessary, a fuel pipe 4 x 1 (di = Ø 2 mm) can be used for diesel heaters instead of the fuel pipe 4 x 1.25 (di = Ø 1.5 mm), Item (5).

The details regarding the pipe lengths remain unchanged.  
The fuel pipe, 4 x 1 must be ordered separately, please refer to the spare parts list or product overview for the Order No.

**Please note!**

Items (1) and (3) are included in the "tank connection" kit.

#### Possible pipe lengths



**Caution!**

**Safety instructions for the fuel supply!**

- The fuel must not be conveyed by gravity or overpressure in the fuel tank.
- Withdrawal of fuel after the vehicle's fuel pump is not allowed.
- When the pressure in the fuel pipe is more than 0.2 bar to max. 4 bar, use a pressure reducer (order no. 22 1000 20 08 00) or separate tank connection.
- When the pressure in the fuel pipe is more than 4 bar or there is a non-return valve in the return pipe (in the tank), a separate tank connection must be used.
- When using a T-piece in a plastic pipe, always use support sleeves in the plastic. Connect the T-piece and the plastic pipe with corresponding fuel hoses and secure with hose clips.

### 3 Installation

#### Fuel supply

##### Installation position of the metering pump

Always mount the metering pump with the pressure side rising upwards. Every installation position over 15° is allowed, although an installation position between 15° and 35° is preferable.

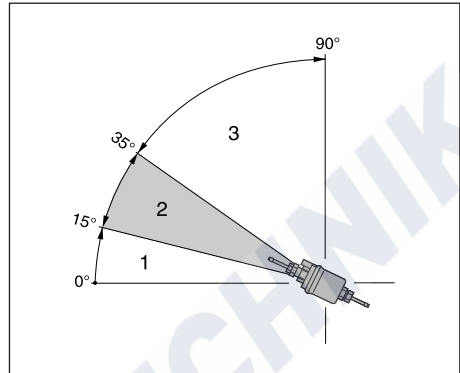

- 1 Installation position between 0° and 15° is not allowed
- 2 Preferred installation position in range 15° to 35°
- 3 Installation position in range 35° to 90° is allowed

##### Possible suction and pressure height of the metering pump

Pressure height from vehicle tank to metering pump:  
a = max. 3000 mm

Intake height in pressure-less vehicle tank:  
b = max. 500 mm for petrol  
b = max. 1000 mm for diesel

Intake height in vehicle tanks with withdrawal by negative pressure (valve with 0.03 bar in tank cap):  
b = max. 150 mm for petrol  
b = max. 400 mm for diesel

Pressure height of the metering pump to the heater:  
c = max. 2000 mm

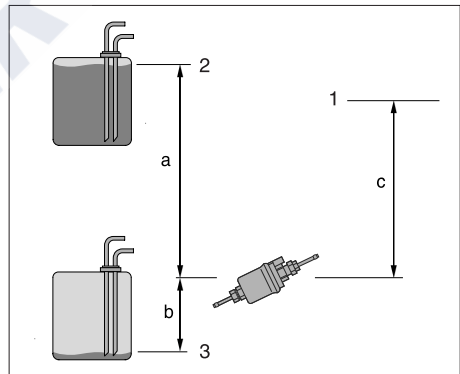

- 1 Connection to heater
- 2 Max. fuel level
- 3 Min. fuel level

**Please note!**

Check tank venting.



**Caution!**

**Safety instructions for installing the metering pump**

- Always mount the metering pipe with the pressure side rising upwards – minimum incline 15°.
- Protect the metering pump and filter from intolerable heat, do not mount near to the silencers and exhaust pipes.



### 3 Installation

#### Fuel supply

##### Fuel quality for petrol heaters

The heater can run on commercially available fuel as per DIN EN 228, as used in the vehicle tank.

##### Fuel quality for diesel heaters

The heater can run on commercially available fuel as per DIN EN 590, as used in the vehicle tank.

##### Fuel for special cases

In special cases (above 0 °C), the heater can also run on fuel oil EL or paraffin.

##### Fuel for low temperatures

Refineries and fuel service stations automatically adjust the fuel to normal winter temperatures (winter diesel). This means that difficulties are only to be expected for extreme drops in temperature, as also apply to the vehicle engine. Please also refer to the vehicle manual.

If the heater is run from a separate tank, please comply with the following rules:

For temperatures above 0 °C, any kind of diesel fuel as per DIN EN 590 can be used.

If no special diesel fuel is available for low temperatures, then paraffin or petrol should be mixed with the fuel according to the following table:

Temperature	Winterdiesel	Addition
0 °C to -25 °C	100 %	-
-25 °C to -40 °C	50 %*	50 % paraffin or petrol

\* or 100 % special cold diesel fuel (Arctic diesel)

**Please note!**

... used oil are **not** allowed!

- After refuelling with winter or cold diesel or the listed blends, the fuel pipes and the metering pump must be filled with the new fuel by letting the heater run for 15 mins.!

##### Operation with biodiesel (FAME)

The diesel heater is **not** approved for operation with biodiesel fuel (FAME) to EN 14 214.

## 4 Operation and function

### Operating instructions

The heater is operated by a control element.  
Detailed operating instructions are enclosed with the control unit.

#### Please note!

The workshop / garage installing the heater will issue you with the operating instructions.

### Important instructions for operation

#### Safety checks before the start

After a lengthy period of non-use (summer months) check that all parts fit securely (tighten screws where necessary).  
Check the fuel system visually for any leaks.

#### Before switching on

Before switching on or pre-programming the heater, adjust the heating control in the vehicle to "WARM" (maximum setting) and the fan to "slow" (low power consumption).  
In vehicles with automatic heating, adjust the heating control to "MAX" and open the heating vents before switching the ignition off.

Pre-venting with change-over "heating / venting"  
Pre-venting means the possibility of starting the vehicle fan directly from the heater preselection timer or, even more convenient, from the radio remote control, thus bypassing the heating mode, so that the passenger compartment, which frequently heats up considerably in summer weather, can be ventilated briefly with fresh air (separate wiring).

#### Heating at high altitudes

When using the heater at high altitudes, please note:

- Heating at altitudes up to 1500 m:
  - Unlimited heating possible.
- Heating at altitudes over 1500 m – 3000 m:
  - Heating is possible for short periods at this altitude (e.g. driving over a mountain pass or taking a break in a journey).
  - During longer stays, e.g. winter camping, the fuel supply must be adjusted to the altitude. This can be done by installing an air pressure sensor. The air pressure sensor is included in the Altitude kit - Order No. 22 1000 33 22 00.

#### Please note!

Heaters suitable for high altitudes are labelled with "H-Kit" on the side nameplate.

### Initial commissioning

The following points are to be checked by the company installing the heater during initial commissioning.

- After installation of the heater, the coolant circuit and the whole fuel supply system must be vented carefully. Comply with the instructions issued by the vehicle manufacturer.
- Open the coolant circuit before the trial run (set the temperature control to "WARM").
- During the trial run of the heater, check all water and fuel connections for leaks and firm fitting.
- If the heater shows a fault during operation, find and eliminate the cause of the fault using a diagnosis unit.

### Description of functions

#### Switching on (pre-heating mode)

When switched on, the operating display in the control unit lights up. The water pump starts up.  
After a specific program sequence the combustion air fan, glow plug and metering pump start up and initiate combustion. Once a stable flame has formed, the glow plug switches off under time control.

#### Heating mode

Depending on heating requirements, the heater is adjusted in the following stages:  
LARGE – SMALL – OFF (Pause).  
The temperature limits are permanently programmed in the electronic controller.  
If the heating requirements in the "SMALL" stage are so small that the cooling water temperature reaches 85 °C, the heater goes into the pause mode.  
The heater continues to run on for approx. 120 seconds, then it switches off (Pause mode).  
The control lamp lights up and the water pump continues to run, even in the pause mode.

#### Please note!

To compensate for the low heating requirements coming from the vehicle engine, the heater can be operated as pre-heater or combined pre-heater and extra heater, depending on the settings (wiring see circuit diagram).



## 4 Operation and function

### Control and safety devices

The heater is equipped with the following control and safety devices.

- If the heater does not ignite within 90 seconds after starting the fuel pump, the start is repeated. If the heater still does not ignite after another 90 seconds, the heater is switched off. After an unacceptable number of failed start attempts, the controller is locked.\*
- If the flame goes off by itself during operation, the heater is restarted.  
If the heater does not ignite within 90 seconds after the fuel pump has started, or ignites and goes off again within 15 minutes, the heater is switched off. This status can be remedied by briefly switching off and on again.
- In the case of overheating (e.g. lack of water, poorly vented coolant circuit), the overheating sensor triggers, the fuel supply is interrupted and the heater switched off.  
Once the cause of overheating has been eliminated, the heater can be re-started by switching off and on again (on condition that the heater has cooled down again sufficiently, cooling water temperature <70 °C). After the heater has been switched off for overheating an unacceptable number of times, the controller is locked.\*
- The heater is switched off if the upper or lower voltage limit is reached.
- The heater does not start up when the glow plug is defect or when the electric lead to the metering pump is interrupted.
- The speed of the fan motor is monitored continuously. If the fan motor does not start up, if it is blocked or if the speed falls below 40 % of the nominal speed, the heater is switched off after 60 sec.

\* The control box can be unlocked with testing equipment / a control unit. For the procedure and description for testing equipment and control units, see "Installation Instructions Plus – EasyStart/Altitude Kit / Special Functions and Diagnosis".

For operation and fault list, please refer to the enclosed operating instructions or the troubleshooting and repair instructions for the heater.

#### Please note!

Do not switch the heater off and on again more than twice.

#### Emergency shutdown – EMERGENCY OFF

If an emergency shutdown – EMERGENCY OFF – is necessary during operation, proceed as follows:

- Switch the heater off with the control or
- pull the fuse out or
- disconnect the heater from the battery.

## 5 Electrical system

### Heater wiring



#### Caution!

#### Safety instructions for wiring the heater!

The heater is to be connected up electrically according to the EMC directives.

EMC can be affected if the heater is not connected up correctly. For this reason, comply with the following instructions:

- Ensure that the insulation of electrical cables is not damaged. Avoid: chafing, kinking, jamming or exposure to heat.
- In waterproof connectors, seal any connector chambers not in use with filler plugs to ensure they are dirt-proof and water-proof.
- Electrical connections and ground connections must be free of corrosion and firmly connected.
- Lubricate connections and ground connections outside the heater interior with contact grease.

#### Please note!

Comply with the following when wiring the heater, the water pump and the metering pump as well as the control unit:

- Electrical leads, switchgear and controllers must be arranged in the vehicle so that they can function perfectly under normal operating conditions (e.g. heat exposure, moisture etc.).
- The following cable cross sections are to be used between the battery and heater. This ensures that the max. tolerable voltage loss in the cables does not exceed 0.5 V for 12 V or 1 V for 24 V rated voltage.  
Cable cross sections for a cable length of:  
– up to 5 m (plus cable + minus cable) = cable cross section 4 mm<sup>2</sup>  
– from 5 to 8 m (plus cable + minus cable) = cable cross section 6 mm<sup>2</sup>
- If the plus cable is to be connected to the fuse box (e.g. terminal 30), the vehicle cable from the battery to the fuse box must be included in rating the overall cable length and possibly re-dimensioned if necessary.
- Use the adapter cable supplied to connect the “heater” cable harness to the water pump.
- Insulate unused cable ends.

### Parts list for circuit diagram, heater and cable harness

-A10	Control box
-B1	Temperature sensor
-B2	Overheating sensor
-B5	Flame sensor
-M1	Burner motor
-M10	Water pump
-R1	Glow plug
-XB9	Bush housing, water pump
-XB9/1	Bush housing, water pump plug-in connection
-XS1	Connector housing, heater signals
-XS9/1	Connector housing, water pump plug-in connection to the cable harness
a	Activation, vehicle fan
-A30	Fuse holder, 3 pin
-F1	Fuse, heater
-F2	Fuse, control unit
-F3	Fan relay fuse
-K1	Fan relay
-K3	Heat switch < 5 °C
-XB1	Bush housing, heater signals
-XB7	Relay block
-XB8	Bush housing, metering pump plug-in connection
-XB8/1	Bush housing, metering pump
-XB10	Bush housing, temperature switch plug-in connection
-XS8	Connector housing, metering pump plug-in connection
-Y1	Fuel metering pump to the heater
a	to the heater
c	to the control unit
d	Connect to D+ for auxiliary heater option
k	Auxiliary heater switch (e.g. outside temperature < 5 °C or summer/winter changeover)
x	Insulate cable and tie back

Connectors and bush housings are shown from the cable inlet side.

#### Cable colours

RD	red	GR	grey	BK	black
BU	blue	YE	yellow	GN	green
WH	white	VT	violet	BN	brown
OR	orange				





## 5 Electrical system

### Heater circuit diagram

- X:15 ○ Ign (+)
- X:58 ○ Light (+)
- X:30 ○ Bat (+)
- X:31 ○ Bat (-)

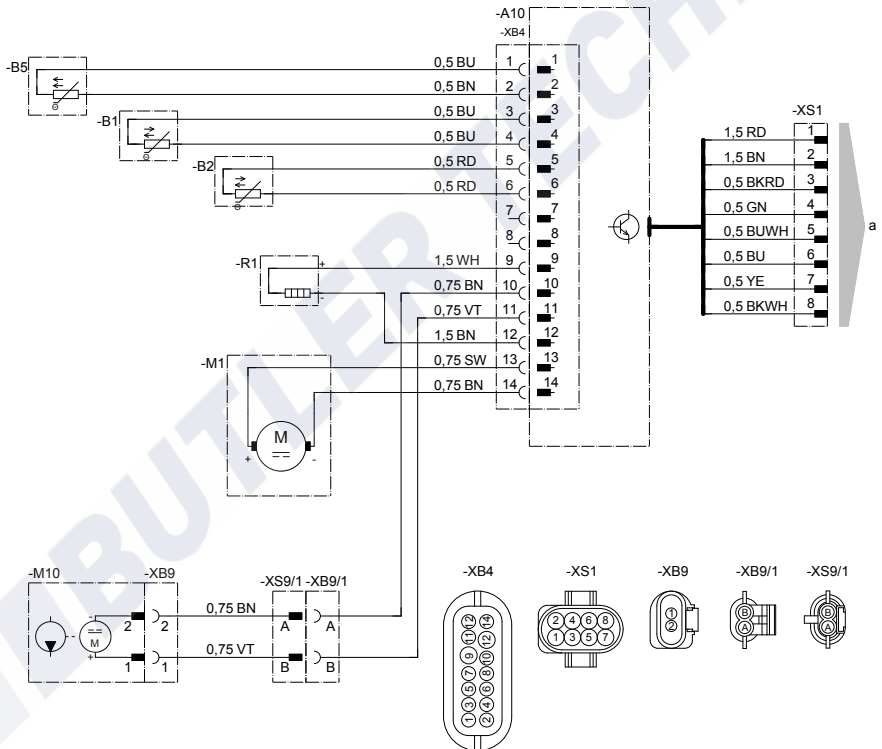

20.1777.00.9601

## 5 Electrical system

### Cable harness circuit diagram

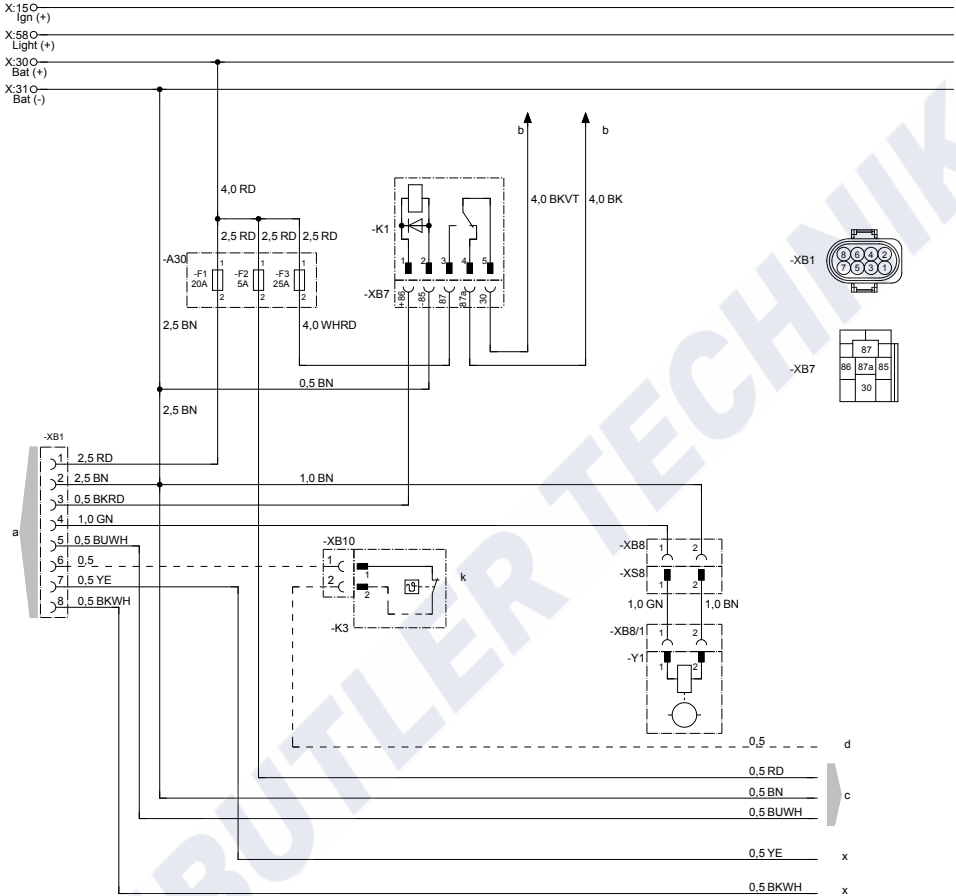

20.1777.00.9602



## 5 Electrical system

### EasyStart Timer circuit diagram

X:15 Ign (+)  
 X:58 Light (+)

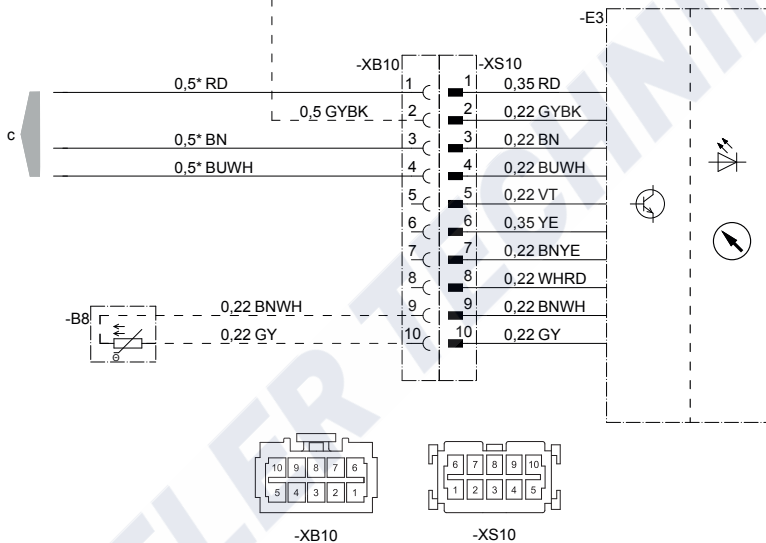

22.1000.34.9701

-B8 Room temperature sensor (optional)  
 -E3 EasyStart Timer  
 c to the cable harness

Connectors and bush housings are shown from the cable inlet side.

#### Note

Further circuit diagrams for the EasyStart Timer are printed in the Installation Instructions Plus, these are available to view and download from the Service Portal.

## 5 Electrical system

### EasyStart Remote+ circuit diagram

X:15  
Ign (+)

X:58  
Light (+)

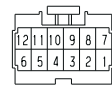
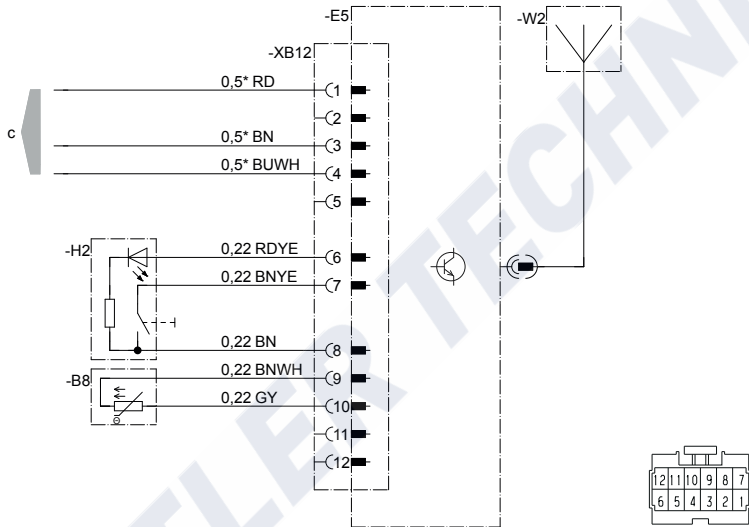

-XB12

22.1000.34.9722

- B8 Room temperature sensor
- E5 Stationary unit, EasyStart Remote+
- H2 Button
- W2 Antenna
- c to the cable harness

Connectors and bush housings are shown from the cable inlet side.

#### **i** Note

Further circuit diagrams for the EasyStart Remote+ are printed in the Installation Instructions Plus, these are available to view and download from the Service Portal.



## 5 Electrical system

### EasyStart Remote circuit diagram

X:15 Ign (+)

X:58 Light (+)

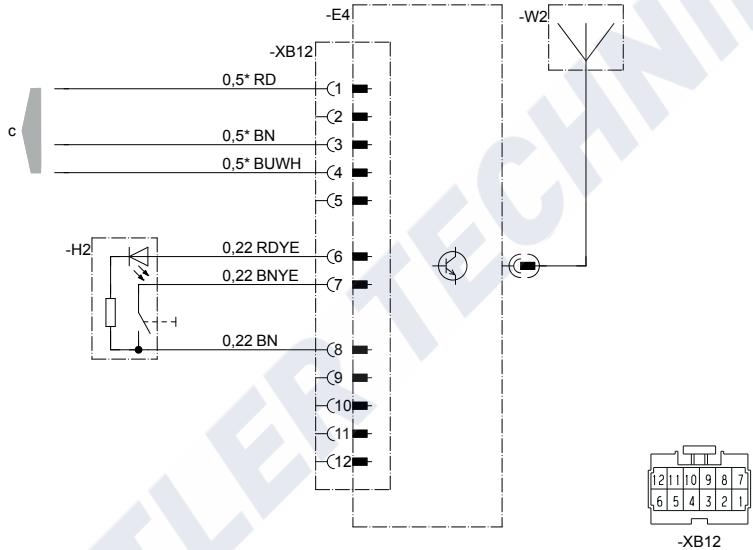

22.1000.34.9733

-E4 Stationary unit EasyStart Remote  
 -H2 Button  
 -W2 Antenna  
 c to the cable harness

Connectors and bush housings are shown from the cable inlet side.

#### Note

Further circuit diagrams for the EasyStart Remote are printed in the Installation Instructions Plus, these are available to view and download from the Service Portal.

## 5 Electrical system

### EasyStart Select circuit diagram

X:15  
Ign (+)  
X:58  
Light (+)

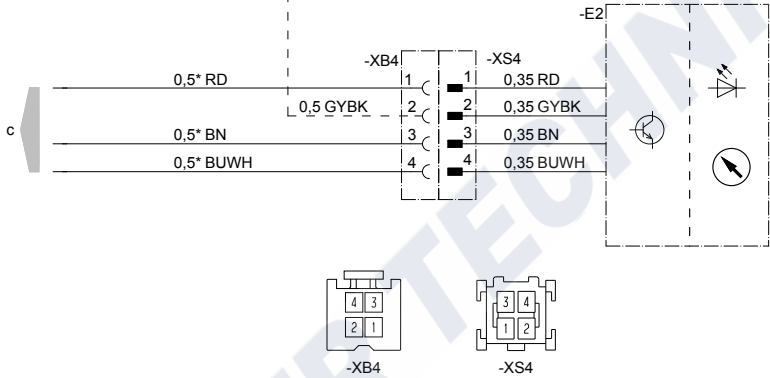

22.1000.34.9734

-E2 EasyStart Select  
c to the cable harness

Connectors and bush housings are shown from the cable inlet side.

**i Note**

Further circuit diagrams for the EasyStart Select are printed in the Installation Instructions Plus, these are available to view and download from the Service Portal.



## 5 Electrical system

### EasyStart Web circuit diagram

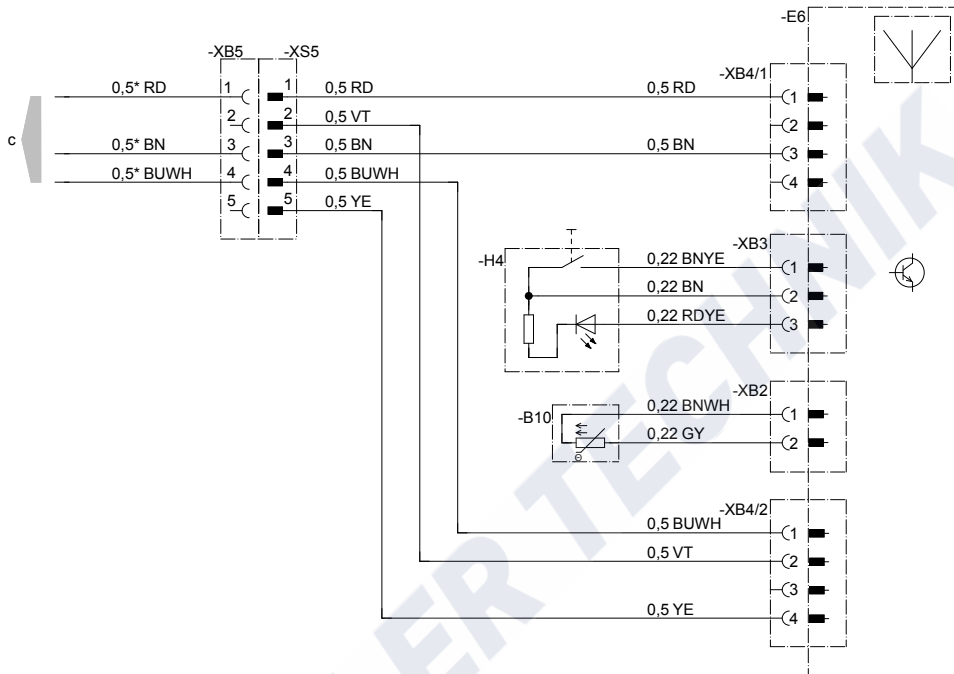

22.1000.34.9719

-B10 Room temperature sensor  
 -E6 EasyStart Web  
 -H4 Button  
 c to the cable harness

Connectors and bush housings are shown from the cable inlet side.



#### Note

Further circuit diagrams for the EasyStart Web are printed in the Installation Instructions Plus, these are available to view and download from the Service Portal.

## 6 Troubleshooting / Maintenance / Service

### In case of faults, please check the following points

- If the heater does not start after being switched on:
  - Switch the heater off and on again.
- If the heater still does not start, check whether:
  - There is fuel in the tank?
  - The fuses are OK?
  - The electrical cables, connections etc. are OK?
  - Anything is clogging the combustion air supply or exhaust system?

### Troubleshooting

If the heater remains faulty even after these points have been checked, or another malfunction occurs in your heater, please contact:

- For installation ex works, your contract workshop.
- For subsequent installation, the workshop who installed your heater.

#### Please note!

Please note that warranty claims can become void if the heater is changed by a third party or by this installation of third party parts.

### Maintenance instructions

- Switch the heater on once a month for about 10 minutes, even outside the heating period.
- Before the heating period starts, the heater should undergo a trial run.  
If persistent extreme smoke develops, unusual burning noises or a clear fuel smell can be perceived or if electric / electronic parts heat up, the heater must be switched off and put out of service by removing the fuse.  
In this case, the heater should not be started up again until it has been checked by qualified staff who have been trained on Eberspächer heaters.
- Check the openings of the combustion air supply and exhaust system after longer standstill periods, clean if necessary!

### Initial commissioning

The following points are to be checked by the company installing the heater during initial commissioning.

- After installation of the heater, the coolant circuit and the whole fuel supply system must be vented carefully. Comply with the instructions issued by the vehicle manufacturer.
- Open the coolant circuit before the trial run (set the temperature control to "OPEN").
- During the trial run of the heater, check all water and fuel connections for leaks and firm fitting.
- If the heater shows a fault during operation, find and eliminate the cause of the fault using a diagnosis unit.

### Service

#### Technical Support

If you have any technical questions or problems with the heater, the control unit or the operating software, please contact the following service address:  
support-UK@eberspaecher.com





## 7 Environment

### Certification

The high quality of Eberspächer's products is the key to our success.

To guarantee this quality, we have organised all work processes in the company along the lines of quality management (QM). Even so, we still pursue a large number of activities for continuous improvement of product quality in order to keep pace with the similarly constantly growing requirements made by our customers.

All the steps necessary for quality assurance are stipulated in international standards.

This quality is to be considered in a total sense.

It affects products, procedures and customer/supplier relationships.

Officially approved public experts assess the system and the corresponding certification company awards a certificate.

Eberspächer Climate Control Systems GmbH has already qualified for the following standards:

**Quality management as per  
ISO TS 9001:2015 and IATF 16949:2016**

**Environment management system as per  
ISO 14001:2015**

### Disposal

#### Disposal of materials

Old devices, defect components and packaging material can all be separated and sorted into pure-grade fractions so that all parts can be disposed of as required in an environment-friendly manner or recycled where applicable.

Electric motors, controllers and sensors (e.g. temperature sensors) are deemed to be "electronic scrap".

#### Dismantling the heater

The heater is dismantled according to the repair stages in the current troubleshooting / repair instructions.

#### Packaging

The packaging of the heater can be kept in case it has to be sent back.

### EU Declaration of Conformity

We herewith declare that the version of the heater placed on the market by us conforms to the applicable provisions of the following EU Directive.

EU Directive 2014/30/EU



The full Declaration of Conformity can be viewed and downloaded from the download centre under [www.eberspaecher.com](http://www.eberspaecher.com).

### UKCA Declaration of Conformity

We herewith declare that the version of the heater placed on the market by us conforms to the applicable provisions of the following EU Directive.

Electromagnetic Compatibility, Statutory Instrument 2016, No. 1091



The full Declaration of Conformity can be viewed and downloaded from the download centre under [www.eberspaecher.com](http://www.eberspaecher.com).

## 8 List

---

### List of abbreviations

**ADR**

European agreement about the international transport of dangerous goods on the road.

**EC type approval**

Permit awarded by the Federal Vehicle Office for the production of a heater for installation in motorised vehicles.

**EMC directive**

Electromagnetic compatibility.

**JE partner**

Eberspächer partner.

**FAME**

Biodiesel as per DIN EN 14 214.

[www.eberspaecher.com](http://www.eberspaecher.com)

Eberspächer Climate Control  
Systems GmbH  
Eberspächerstr. 24  
73730 Esslingen  
Germany  
info@eberspaecher.com  
www.eberspaecher.com



Eberspächer®