

HYDRONIC L D16W

Technical description, installation,
operation and maintenance instructions.



Heater

HYDRONIC L D 16 W N
HYDRONIC L D 24 W N
HYDRONIC L D 30 W N
HYDRONIC L D 35 W N

Order No. – normal version

25 2165 02 00 00
25 1817 02 00 00
25 1818 02 00 00
25 1819 02 00 00

Order No. – compact version

25 1817 05 00 00
25 1818 05 00 00
25 2041 05 00 00

**Water heaters for diesel fuel, operating
operating independently of an engine.**



Eberspächer

1 Introduction

Contents

Chapter	Title	Contents	Page
1	Introduction	<ul style="list-style-type: none"> • Contents..... 2 • Concept of this manual..... 3 • Special text structure, presentation and picture symbols 4 • Important information before starting work..... 4 • Statutory regulations5, 6 • Safety instructions for installation and operation..... 7 • Accident prevention 7 	
2	Product information	<ul style="list-style-type: none"> • Scope of supply / additional parts.....8, 9 • Technical data, heater 10 • Technical data, water pump..... 11 • Pumping and pressure loss characteristic curves 11 • Main heater dimensions, normal version..... 12 • Main heater dimensions, compact version 12 	
3	Installation	<ul style="list-style-type: none"> • Permissible installation position and fastening of the heater 13 • Installation location 14 • Installing the heater in a box..... 15 • Nameplate..... 15 • Exhaust system (pipes).....16, 17 • Combustion air system 18 • Connection to the cooling water circuit..... 19 • Water circuit..... 19 • Fuel supply 20 – 22 	
4	Operation and function	<ul style="list-style-type: none"> • Structure of the heater 23 • Special features of the heater..... 23 • Operation instructions / important information for operation 23 • Initial commissioning of the heater 23 • Functional description 24 • Control and safety devices / EMERGENCY OFF 25 	
5	Electrical system	<ul style="list-style-type: none"> • Heater wiring..... 26 • Parts list / circuit diagram, heater – Part 1 27 • Parts list / circuit diagram, heater – Part 2..... 28 • Parts list / circuit diagram, control units..... 29 • Parts list, EasyStart control units..... 33 • Circuit diagrams, EasyStart control units..... 31 – 33 	
6	Faults Maintenance Service	<ul style="list-style-type: none"> • If any faults occur, please check the following items..... 34 • Troubleshooting..... 34 • Maintenance instructions 34 • Changing components..... 34 • Service..... 34 	
7	Environment	<ul style="list-style-type: none"> • Certifications 35 • Disposal 35 • EC Declaration of Conformity 35 • UKCA Declaration of Conformity..... 35 	
8	Lists	<ul style="list-style-type: none"> • Index 36 • List of abbreviations 37 	



1 Introduction

Concept of this manual

This manual aims to support the service company installing the heater and to provide the user with all important information about the heater.

The manual has been divided into 8 chapters to make it easier to find the corresponding information quickly.

1 Introduction

Here you find important introductory information about installation of the heater and about the structure of the manual.

2 Product information

Here you will find information about the scope of supply, the technical data and the dimensions of the heater.

3 Installation

Here you will find important information and instructions referring to installation of the heater.

4 Operation and function

Here you will find information about the operation and function of the heater.

Electrical system

5

Here you will find information about the heater's electrics and electronic components.

6

Troubleshooting / maintenance / service

Here you will find information about possible faults, troubleshooting, servicing / maintenance and the service hotline.

7

Environment

Here you will find information about certification and disposal of the heater together with the EC Declaration of Conformity.

8

Lists

Here you will find the key word list and abbreviations list.

1 Introduction

Special text structure, presentation and picture symbols

This manual uses special text structures and picture symbols to emphasize different contents. Please refer to the following examples for their meanings and appropriate action.

Special text formats and presentations

A dot (•) indicates a list which is started by a heading. If an indented dash (–) follows a dot, this list is subordinate to the dot.

Picture symbols



Regulation!

This picture symbol with the remark "Regulation!" refers to a statutory regulation. Failure to comply with this regulation results in expiry of the type-approval for the heater and preclusion of any guarantee and liability claims on Eberspächer Climate Control Systems GmbH.



Danger!

This picture symbol with the remark "Danger!" refers to the risk of a fatal danger to life and limb. Under certain circumstances, failure to comply with these instructions can result in severe or life-threatening injuries.



Important!

This picture symbol with the remark "Caution!" refers to a dangerous situation for a person and / or the product. Ignoring this information can result in injuries to people and / or damage to machinery.

Please note!

Recommendations for use and useful tips for the heater.

Important information before starting work

Range of application of the heater

The water heater operating independently of an engine is intended for installation in the following vehicles:

- All types of motor vehicles, especially buses and coaches
- Construction machinery
- Agricultural machinery
- Boats, ships and yachts
- Rail vehicles

Please note!

The heater **cannot** be installed in vehicles used for the transport of dangerous goods according to ADR.

Intended purpose of the heater (via the vehicle's own heat exchanger)

- Pre-heating, de-misting windows
- Heating and keeping the following warm:
 - Driver and working cabs
 - Freight compartments
 - Ship's cabins
 - Passenger and crew compartments
 - Vehicle engines and units

On account of its functional purpose, the heater is **not** approved for the following applications:

- Long-term continuous operation, e.g. for pre-heating and heating of:
 - Residential rooms
 - Garages
 - Work huts, weekend homes and hunting lodges
 - Houseboats, etc.



Important!

Safety instructions for the range of application and proper, intended use!

The heater must only be used and operated for the range of application stated by the manufacturer and in compliance with the operation instructions included with every heater.



1 Introduction

Statutory regulations

The Federal Road Transport Directorate has issued an "EC type approval" and an "EMC type-approval" for the heater for installation in motor vehicles and with the following official type-approval marks, noted on the heater name plate.

HYDRONIC L EC- e1 00 0030
EMC-e1 031076

The Federal Railway Office has issued a "type approval to Art 33 EBO" for installation of the heater in rail vehicles; the vehicle has the following official type approval:

HYDRONIC L EBA-32AZ3/0110/05

§ Regulations!

Directive 2001 / 56 / EC of the European Parliament and the Council

• Position of the heater

- Parts of the structure and other components near the heater must be protected from excessive heat exposure and possible fuel or oil contamination.
- The heater must not pose a fire hazard even when it overheats. This requirement is deemed to be fulfilled if adequate clearance is ensured for all parts during installation, sufficient ventilation is provided and fireproof materials or heat shields are used.
- The heater must not be mounted in the passenger compartment of vehicles in class M₁, M₂, M₃ and N. But a heater in a hermetically sealed enclosure which otherwise complies with the conditions stated above may be used.
- The factory nameplate or duplicate of it must be affixed so that it can still be easily read when the heater is installed in the vehicle.
- All appropriate precautions must be taken when arranging the heater to minimise the risk of injuries to persons or damage to other property.

• Fuel supply

- The fuel intake connection must not be located in the passenger compartment and must be sealed with a properly closing lid to prevent any fuel leaks.
- In heaters for liquid fuel where the heater fuel is separate from the vehicle fuel, the type of fuel and intake connection must be clearly identified.
- A warning sign is to be fixed to the intake connection indicating that the heater must be switched off before refuelling.

• Exhaust system

- The exhaust outlet must be arranged so as to prevent any penetration of exhaust fumes into the vehicle interior through the ventilation system, warm air intakes or open windows.

• Combustion air intake

- The air for the heater's combustion chamber must not be sucked in from the vehicle's passenger compartment.
- The air intake must be arranged or protected in such a way that it cannot be blocked by other objects.

• Operating status display

- A clearly visible operating display in the user's field of vision must indicate when the heater is switched on an off.

Statutory regulations

§ Regulation

The laying of fuel lines and installation of additional fuel tanks must comply with Art 45 and 46 of the StVZO (German road vehicle licensing regulations).

Extract from Art 45 and 46 StVZO:

- Fuel tanks in buses and coaches must not be located in the passenger compartment or driver's cab. They must be positioned in such a way that if a fire occurs the exits are not at immediate risk.
- Fuel lines in buses and coaches must not be located in the passenger compartment or driver's cab.
- The heater may not be installed in classes M₁ and N₁, as the end-of-life vehicles regulations (EC End-of-Life Vehicles Directive 2000/53/EC) is not complied with.

1 Introduction



Regulations

Additional regulations for certain vehicles named in Directive 94 / 55 / EC (ADR Framework Directive)

Scope

This appendix applies to vehicles for which the special provisions of Directive 94 / 55 / EC apply to combustion heaters and their installation.

Definition of terms used

For the purposes of this appendix, the vehicle designations „EX / II“, „EX / III“, „AT“, „FL“ and „OX“ according to Chapter 9.1 of Annex B of Directive 94 / 55 / EC are used.

Technical regulations

General provisions (EX / II, EX / III, AT, FL and OX vehicles)

Avoid heating and ignition

The combustion heaters and their exhaust gas routing shall be designed, located, protected or covered so as to prevent any unacceptable risk of heating or ignition of the load. This requirement shall be considered as fulfilled if the fuel tank and the exhaust system of the appliance conform to provisions in 3.1.1.1 and 3.1.1.2. Compliance with these regulations shall be checked in the complete vehicle.

Fuel tanks

Fuel tanks for supplying the heater shall conform to the following regulations:

- In the event of any leakage, the fuel shall drain to the ground without coming into contact with hot parts of the vehicle or the load;
- fuel tanks containing petrol shall be equipped with an effective flame trap at the filler opening or with a closure enabling the opening to be kept hermetically sealed.

Exhaust system and exhaust pipe layout

The exhaust system as well as the exhaust pipes shall laid out or protected to avoid any danger to the load through heating or ignition. Parts of the exhaust system situated directly below the fuel tank (diesel) shall have a clearance of at least 100 mm or be protected by a thermal shield.

Switching on the combustion heater

The combustion heater may only be switched on manually. Automatic switching on via a programmable switch is not permitted.

EX / II and EX / III vehicles

Combustion heaters for gaseous fuels are not permitted.

FL vehicles

Combustion heaters must be able to be taken out of service/disabled at least by the methods described in the following:

- a) Switching off manually in the driver's cabin

- b) Switching off the vehicle's engine; in this case the heater may be manually switched back on by the vehicle driver;
- c) Starting up of a feed pump installed in the vehicle for the dangerous goods carried.

Combustion heater after-run

After-running of the switched off combustion heater is permitted. In the cases named in the „FL vehicles“ paragraph under letters b) and c) the supply of combustion air must be interrupted by suitable means after a maximum after-run period of 40 seconds. Only combustion heaters whose heat exchangers are verifiably not damaged by the reduced after-run period of 40 seconds beyond their usual use period may be used.

Please note!

- Compliance with the statutory regulations, the additional regulations and safety instructions is prerequisite for guarantee and liability claims.
Failure to comply with the statutory regulations and safety instructions and incorrect repairs even when using original spare parts make the guarantee null and void and preclude any liability for Eberspächer Climate Control Systems GmbH.
- Subsequent installation of this heater must comply with these installation instructions.
- The statutory regulations are binding and must also be observed in countries which do not have any special regulations.
 - When the heater is to be installed in vehicles not subject to the German Ordinance for the Registration of Motor Vehicles (StVZO), for example ships, the specially valid regulations and installation instructions for these special applications must be observed.
- Installation of the heater in special vehicles must comply with the regulations applying to such vehicles.
- Other installation requirements are contained in the corresponding sections of this manual.



1 Introduction

Safety instructions for installation and operation



Danger!

Risk of injury, fire and poisoning

- Disconnect the vehicle battery before starting any kind of work.
- Before working on the heater, switch the heater off and let all hot components cool down.
- The heater must not be operated in enclosed rooms, e.g. in the garage or multi-storey car park.



Caution!

Safety instructions for installation and operation

- The heater must only be installed by a JE partner authorised by the manufacturer according to the instructions in this manual and possibly according to special installation recommendations; the same applies to any repairs to be carried out in the case or repairs or guarantee claims.
- Repairs by non-authorised third-parties or with not original spare parts are dangerous and therefore not allowed. They result in expiry of the type permit of the heater; consequently, when installed in motor vehicles they can cause expiry of the vehicle operating licence.
- The following measures are not allowed:
 - Changes to components relevant to the heater.
 - Use of third-party components not approved by Eberspächer Climate Control Systems GmbH.
 - Nonconformities in installation or operation from the statutory regulations, safety instructions or specifications relevant to safe operation as stated in the installation instructions and operating instructions. This applies in particular to the electrical wiring, fuel supply, combustion air system and exhaust system.
- Only original accessories and original spare parts must be used during installation or repairs.
- Only original accessories and spare parts may be used for installation or repairs.
- Only the controls approved by Eberspächer may be used to operate the heater.
The use of other controls can result in malfunctions.
- Before the heater is installed again in another vehicle, rinse the heater parts carrying water with clear water.
- When carrying out electric welding on the vehicle, the plus pole cable at the battery should be disconnected and placed at

ground to protect the controller.

- The heater must not be operated where there is a risk of an accumulation of flammable vapours or dust, for example close to
 - fuel depot
 - coal depot
 - wood depot
 - grain depots etc.
- The heater must be switched off when refuelling.
- When the heater is mounted in a safety housing etc., the installation compartment of the heater is not a stowage compartment and must be kept clear.
In particular fuel canisters, oil cans, spray cans, gas cartridges, fire extinguishers, cleaning rags, items of clothing, paper etc. must not be stored or transported on or next to the heater.
- Defect fuses must only be replaced by fuses with the prescribed rating.
- If fuel leaks from the heater fuel system, arrange for the damage to be repaired immediately by a JE service partner.
- When topping up the coolant, only use the coolant permitted by the vehicle manufacturer, see the vehicle operating manual. Any blending with unpermitted coolant can cause damage to the engine and heater.
- After-running of the heater must not be interrupted prematurely e.g. by pressing the battery disconnecting switch, apart from in the case of an emergency stop.

Accident prevention

General accident prevention regulations and the corresponding workshop and operation safety instructions are to be observed.

2 Product information

Scope of supply

Figure No.	Designation	Order No.
1	HYDRONIC 16 – 24 volt Normal version	25 2165 02 00 00
1	HYDRONIC 24 – 24 volt Normal version	25 1817 02 00 00
2	HYDRONIC 24 – 24 volt Compact version	25 1817 05 00 00
1	HYDRONIC 30 – 24 volt Normal version	25 1818 02 00 00
2	HYDRONIC 30 – 24 volt Compact version	25 1818 05 00 00
1	HYDRONIC 35 – 24 volt Normal version	25 1819 02 00 00
2	HYDRONIC 35 – 24 volt Compact version	25 2041 05 00 00

The following additional parts are required to run the heater:

- Additional parts for connection to the water circuit
- Additional parts for the fuel supply
- Additional parts for the exhaust system
- Control unit

Additional parts which have to be ordered separately

Figure No.	Designation	Order No.
3	FLOWTRONIC 5000	25 1818 29 00 00
4	FLOWTRONIC 5000S	25 1818 30 00 00
5	FLOWTRONIC 6000S	25 1818 27 00 00
6	Hose clip, \varnothing 40-47 mm	152 00 158
7	Hose elbow, \varnothing 38 mm	360 00 300
8	Connection pipe, \varnothing 38 mm	25 1214 89 00 21
9	T-piece, \varnothing 38-38-38	25 1371 89 04 00
10	Reducer, \varnothing 38/28 mm	25 1214 89 00 19
11	Hose clip, \varnothing 32-39 mm	152 61 097
12	Pipe elbow, \varnothing 38 mm	25 1214 89 00 03
13	Water hose, \varnothing 38 mm	360 75 096
14	Exhaust pipe socket, \varnothing 70 mm	25 2025 89 01 00
15	Exhaust pipe socket, \varnothing 70 mm	22 1000 40 04 00
16	Exhaust pipe elbow, \varnothing 70 mm	22 1000 40 03 00
17	Fuel filter	330 00 052
18	Banjo bolt, M14 x 1.5	104 10 040
19	Sealing ring, A14 x 18	323 16 006
20	Fuel suction line	25 1698 05 03 00
21	Screw fixing, M14 x 1.5	266 42 004
22	Spherical liner	263 35 080
23	Union nut, M14 x 1.5	116 10 040
24	Fuel pipe, Outer diameter \varnothing 6 x 1 (Cu)	
25	Fuel hose, Inner diameter \varnothing 5 x 3	360 75 350
26	Hose clip, \varnothing 11 mm	10 2063 01 10 98
27	Screw fixing, M14 x 1.5	25 1706 05 01 00
28	Ball valve, M14 x 1.5	330 00 019
29	Fuel return line	25 1698 05 04 00
30	Valve	330 00 210
31	Reducing coupling 8 / 6	266 00 026
32	Shroud with hose connection	22 1000 40 06 00
33	1 m flexible hose, \varnothing 60 mm	10 2114 31 00 00
34	Hose clip	10 2064 05 00 70
35	Air hose fixing kit	22 1000 50 02 00
36	Plastic grille	25 1688 80 06 00

* The fuel pipe must be purchased from a specialist dealer.

Please note!

For further additional parts, see additional parts catalogue.



2 Product information

Scope of supply

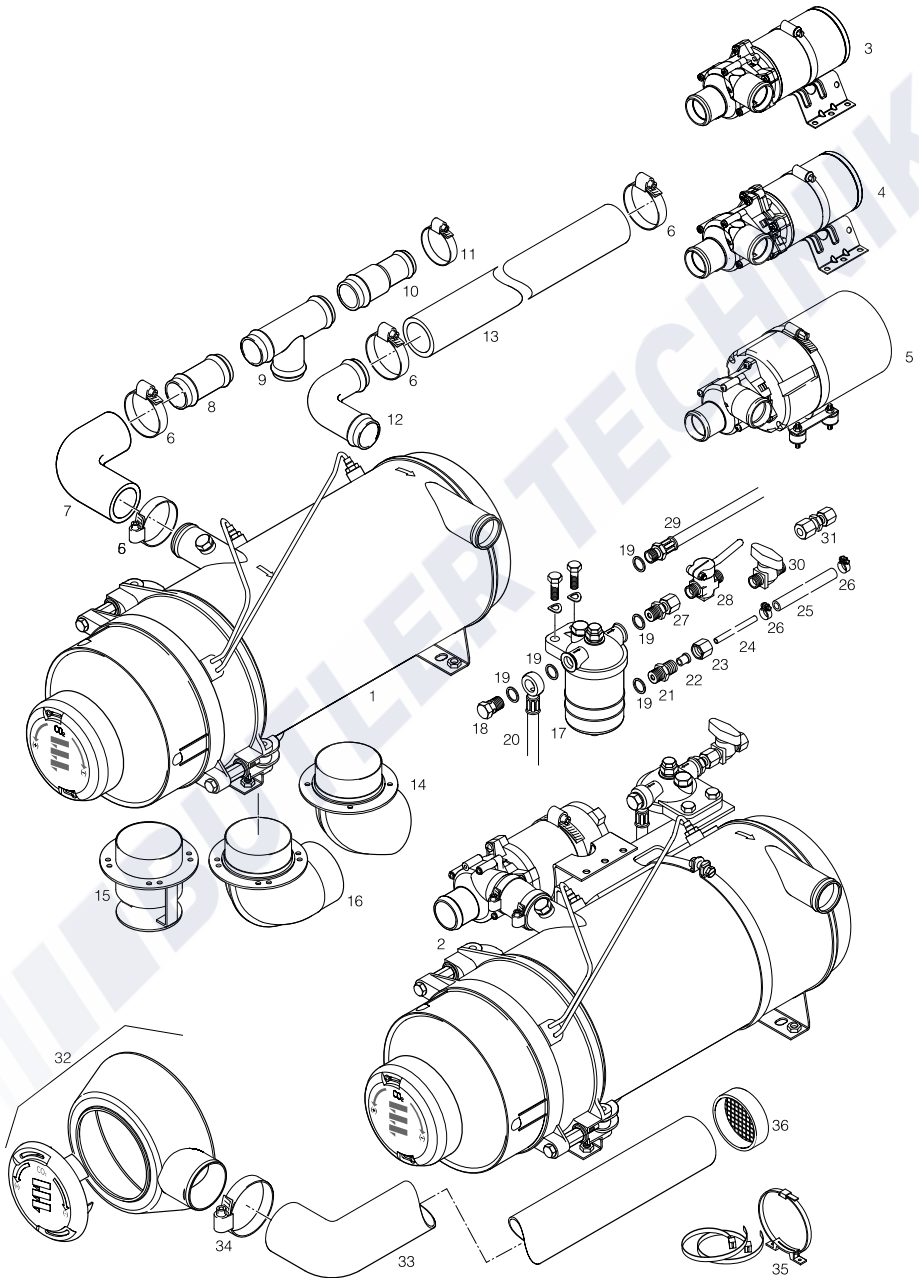

2 Product information

Technical data	HYDRONIC L			
	D 16 W N	D 24 W N	D 30 W N	D 35 W N
Type				
Heating medium	Mixture of water and coolant (max. 50 % coolant)			
Heat flow in watts (at ambient temperature 20 °C)	16 000	24 000	30 000	35 000
Temperature values – at water inlet	ON 73 °C / OFF 78 °C			
Temperature values – at water outlet	ON 85 °C / OFF 118 °C			
Fuel	Diesel – commercially available (DIN EN 590) Heating oil EL (DIN 51603)			
Fuel consumption (at ambient temperature –10 °C)	2.0 l/h	2.9 l/h	3.65 l/h	4.2 l/h
Rated voltage	24 volt			
Operating range				
<ul style="list-style-type: none"> Lower voltage limit: An undervoltage protection installed in the control box switches off the heater if the voltage limit is reached. 	19 volt			
<ul style="list-style-type: none"> Upper voltage limit: An overvoltage protection installed in the control box switches off the heater if the voltage limit is reached. 	30 volt			
Electrical power consumption (in combustion mode / without circulation pump)	60 watt	80 watt	105 watt	120 watt
Water content of the heat exchanger	approx. 2 l			
Water volume of the water circuit	min. 10 l			
Minimum throughput of the heating medium (±200 l/h)	1400 l/h	2000 l/h	2600 l/h	3000 l/h
Permissible ambient temperature	in operation: –40 °C to +85 °C during transport / storage: –40 °C to +100 °C for the combustion air: < 60 °C Pumped fluid: –40 °C to +90 °C, briefly up to +120 °C			
Operating pressure (water circuit)	< 2.5 bar			
CO ₂ values (vol. %)	9 – 11	9 – 11	9 – 11	9,5 – 11,5
CO in the exhaust	< 0.04			
Smoke spot no. (Bacherach)	< 4			
Weight	approx. 18 kg			
Interference suppression class	VHF 4 / SW 3 / MW 5 / LW 3 to DIN 57879 / Part 1 VDE 0879			
Protection	IP 64			

Please note!

Provided no limit values are given, the technical data provided is with the usual heater tolerances of ±10 % at rated voltage, 20 °C ambient temperature and reference altitude Esslingen.



Important!

Safety instructions for technical data

Failure to comply with the technical data can result in malfunctions.



2 Product information

Technical data		FLOWTRONIC 5000	
Heating medium	Mixture of water and coolant (max. 50 % coolant)		
Delivery rate	5200 l/h ± 10 % at 0.2 bar delivery pressure		
Operating pressure, water circuit	max. 2 bar		
Weight (without bracket, clip and coolant)	2.14 kg		
Rated voltage	24 volt		
Operating range	20 – 28 volt		
Power consumption at 5200 l/h and 0.2 bar delivery pressure	104 watt ± 10 %		
Interference suppression class	3 to DIN 57879 / Part 1 VDE 0879		
Protection	IP 54A to DIN 40 050 Sheet 1		
Electrical fusing for third party controls	15 A		
Temperature conditions	Heating medium	-40 °C to 90 °C	short-term (15 min) +115 °C
	Ambient, operating	-40 °C to 90 °C	short-term (15 min) +115 °C
Dry running	No		
Blocking	The engine remains undamaged within a period of max 6 seconds.		
Shaft - impeller connection	Mechanical seal		

Pumping and pressure loss characteristic curves

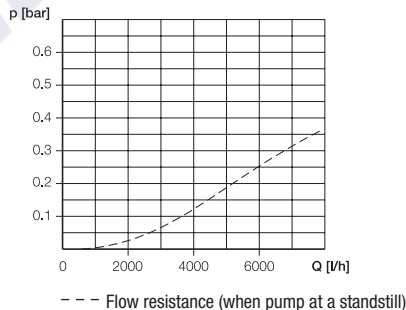
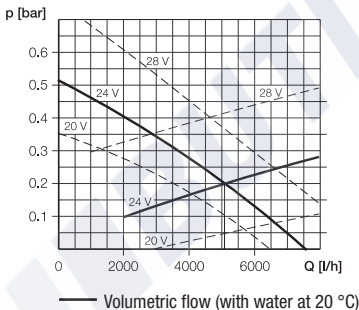

Please note!

- Provided no limit values are given, the technical data provided is with the usual heater tolerances of ± 10 % at rated voltage, 20 °C ambient temperature and reference altitude Esslingen.
- The FLOWTRONIC 5000 water pump is installed in compact heaters.
- If water pumps are ordered separately, please refer to the documentation provided for the relevant technical data, installation positions, etc.



Important!

Safety instructions for technical data

Failure to comply with the technical data can result in malfunctions.

2 Product information

Main dimensions

Heater – normal version

Please note!

- If there is sufficient space the shroud can be removed, the burner swung out and the header pipe dismantled – see sketch.
- The normal version dimensions also apply to the compact version.
- The main dimensions also apply when the shroud is mounted with hose connection.

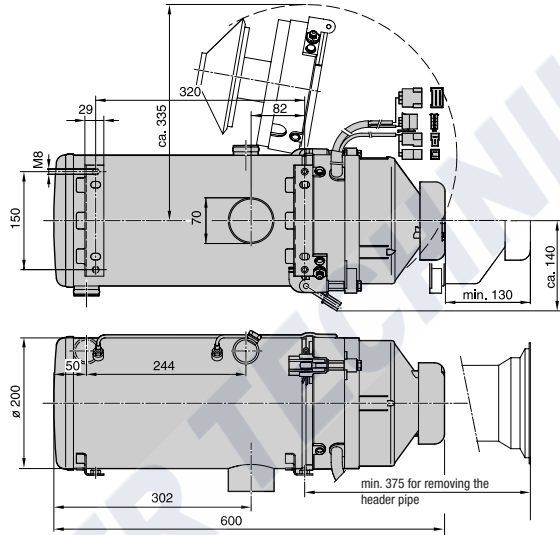
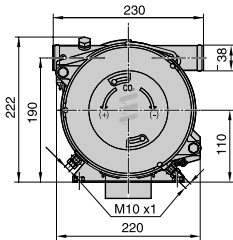

Heaters – compact version

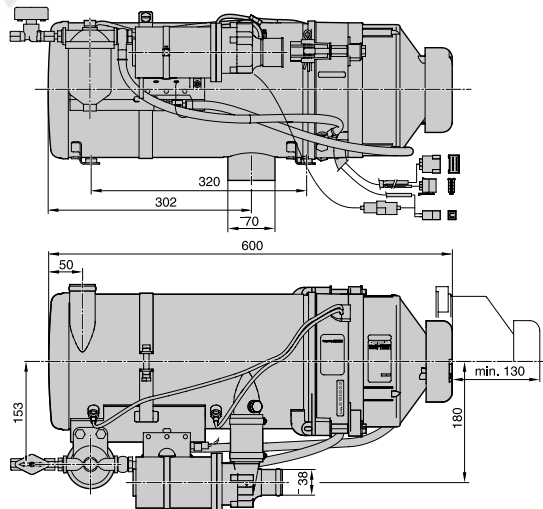
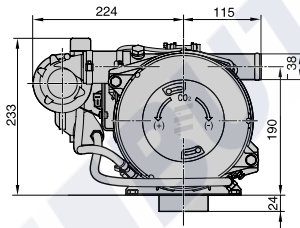



3 Installation

Permissible installation positions and fastening of the heater

The heater should preferably be installed in horizontal position. Transfer the four fastening holes and the through hole for the exhaust fitting to the mounting surface as shown in the drawing and drill accordingly.

Fasten the heater to the vehicle with the two fastening consoles.

Please note!

- The contact surface for the two fastening consoles must be flat.
- Depending on the installation conditions, the heater can be tilted at an angle as shown in the diagrams. In heating mode, the heater can deviate from the normal position by up to +15° in all directions as a result of the slanted position of the vehicle.

Permissible installation positions and hole pattern for the heater – Normal version and compact version

Normal version

– horizontal installation with the deviations shown in the sketch; and vertical installation permissible.

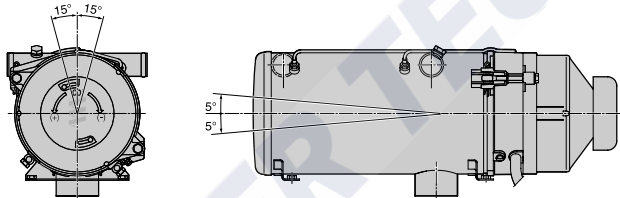

Hole pattern for the heater – Normal and compact version

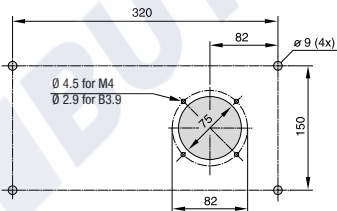

Compact version

– horizontal installation only permitted with the deviations shown in the sketch.

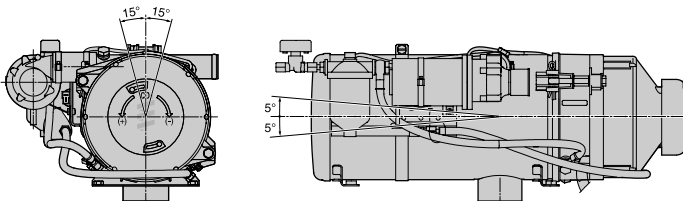

3 Installation

Installation location

The heater should be installed as low as possible in the vehicle, e.g. in the engine compartment or in a stowage compartment. This guarantees automatic ventilation of the heater and the water pump.

Other installation locations are possible if they comply with the installation requirements stated in these installation instructions. When choosing the installation position, space must be left to

dismantle the shroud (130 mm) and the header pipe (375 mm). Breakthroughs to the outside must be splashproof.

Installation example in a bus and in a rail vehicle

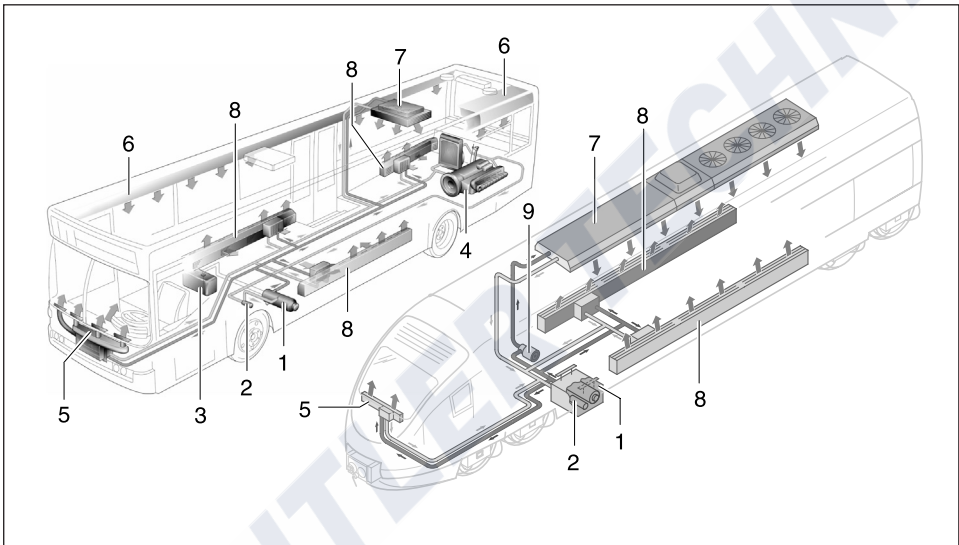

- | | | |
|-------------------|------------------|-------------------------|
| 1 Heater | 4 Vehicle engine | 7 Roof heater |
| 2 Water pump | 5 Front heater | 8 Floor heater |
| 3 Tank connection | 6 Roof air ducts | 9 Additional water pump |

Please note!

- Mount the heater under the minimum cooling water level (header tank, radiator, vehicle heat exchanger).
- Installation requirements (e.g. for boats and ships) are available from the manufacturer on request.



3 Installation

Installing the heater in a box

If the heater cannot be installed in the engine compartment or in a stowage compartment of the vehicle, it can also be installed in a box.

The box with the installed heater is then fixed to the vehicle at a suitable point e.g. longitudinal frame. The installation of a hood with hose connection is recommended for intake of combustion

air.

The combustion air is then sucked in from outside the box through a flexible hose.

A safety grille is to be fitted to the flexible hose.

Installation example – heater in a box

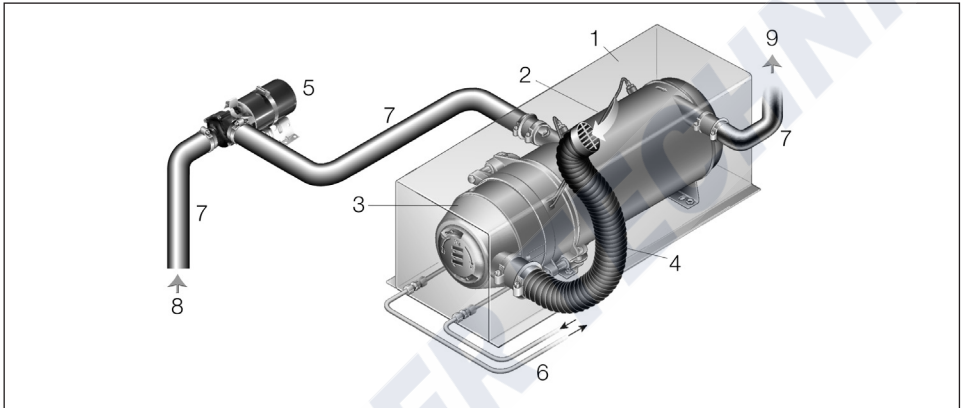

- 1 Box
- 2 Heater
- 3 Shroud with hose connection
- 4 Flexible hose with safety grille
- 5 Water pump
- 6 Fuel lines
- 7 Water hose
- 8 Water inlet
- 9 Water outlet

Please note!

- The box must be adequately ventilated from the outside so that the permissible ambient temperature is not exceeded.
- Ventilation openings must be positioned in the box in such a way that they cannot be clogged up by dirt and snow.
- Any water which penetrates the box must be allowed to drain off.

Nameplate

The nameplate is fastened to the heater. The second nameplate (duplicate) can be adhered to the shroud of the heater, and removed again if necessary.

If required, the duplicate nameplate can be adhered in a clearly visible position on the heater or near to the heater.

Please note!

The regulations and safety instructions to be observed for this chapter are stated on page 5.

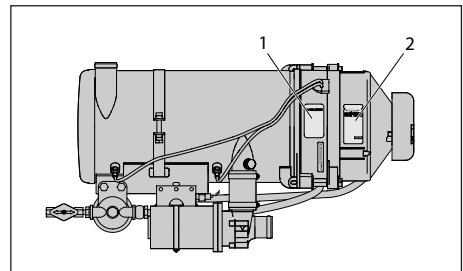

- 1 Original nameplate
- 2 Nameplate (duplicate)

3 Installation

Exhaust system (pipes)



Danger!

Risk of injuries and burns!

Every type of combustion produces high temperatures and toxic exhaust fumes. This is why the exhaust system must always be laid according to these installation instructions.

- Do not perform any work on the exhaust system while the heater is working.
- Before working on the exhaust system, switch off the heater first and wait until all the parts have completely cooled down, wear safety gloves if necessary.
- Do not inhale exhaust fumes.



Important!

Safety instructions for the exhaust system!

- The exhaust pipe must end in the open air.
- The exhaust pipe must not protrude beyond the lateral limits of the vehicle.
- Install the exhaust pipe sloping slightly downwards, if necessary drill a drain hole approx \varnothing 5 mm at the lowest point as a condensation outlet.
- Important functional parts of the vehicle must not be impaired (keep sufficient clearance).
- Install the exhaust pipe with sufficient clearance from heat-sensitive components. Pay particular attention to fuel lines (made of plastic or metal), electrical cables and brake hoses, etc.!
- Exhaust pipes must be safely fixed (recommended clearance of 50 cm) to avoid damage from vibrations.
- Lay the exhaust system so that the outflowing exhaust gases are not sucked in as combustion air.
- The mouth of the exhaust pipe must not become clogged with dirt and snow.
- The mouth of the exhaust pipe must not point in the direction of travel.
- Always fix the exhaust silencer to the vehicle.
- In rail vehicles it is important to ensure that the exhaust opening does not point in one of the possible directions of travel (90° to the direction of travel).

Installing the exhaust system

Push an exhaust pipe elbow or an exhaust pipe socket onto the heater's exhaust connection and fix to the floor of the vehicle. Order No. of the exhaust system parts, see page 8.

As an alternative, a flexible exhaust pipe can be fixed to the heater's exhaust connection with a pipe clip; depending on the installation conditions this can be between 20 cm and max 4 m long.

A rigid or flexible exhaust pipe made from unalloyed or alloyed steel, internal $\varnothing = 70$ mm, is not available at present. If needed the exhaust pipe must be purchased from a specialist store; the wall thickness of the rigid exhaust pipe must be at least 1 mm.

Please note!

- The gas system can be bend by max. $3 \times 90^\circ$, the total length reduces by 0.5 m with each 90° bend.
- Use pipe clips to fix the exhaust pipe to the vehicle floor at suitable places.
- Comply with the regulations and safety instructions for this chapter given on page 4 – 7.



3 Installation

Exhaust system (pipes)

Example for the exhaust system

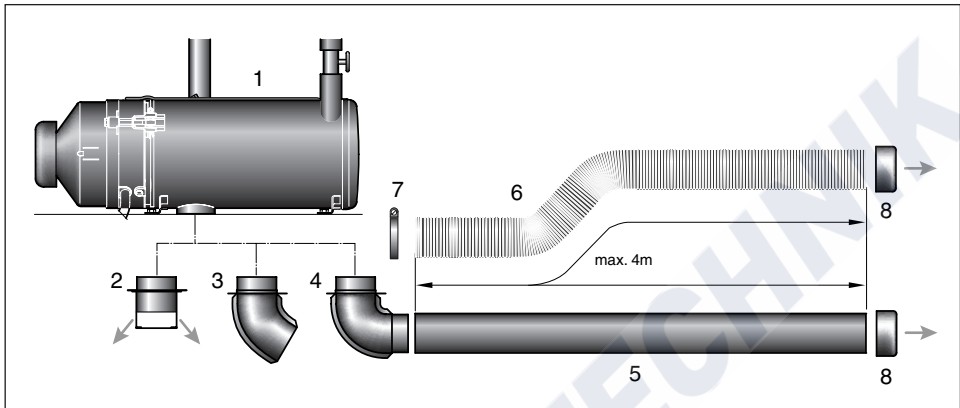

Sketch 1

- 1 Heater
- 2 Exhaust connection
- 3 Exhaust pipe elbow 60°
- 4 Exhaust pipe elbow 90°
- 5 Exhaust pipe
- 6 Flexible exhaust pipe
- 7 Pipe clip
- 8 End sleeve

Please note!

Items 5 – 7 must be purchased from a specialist store.
You must make Item 8 yourself.

End sleeve with separators for exhaust pipe

If necessary you must make an end sleeve with separators (made from metal) for the exhaust pipe yourself.

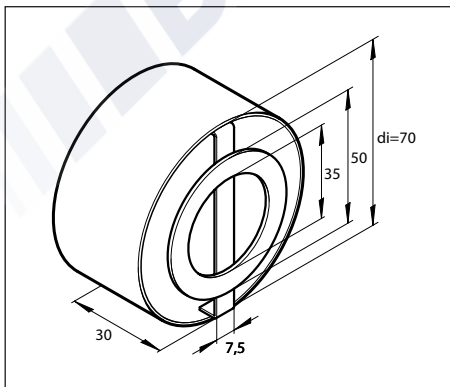

3 Installation

Combustion air system



Important!

Safety instructions for the combustion air system!

- The combustion air opening must be free at all times.
- Position the combustion air intake to be sure that exhaust fumes cannot be sucked in with the combustion air.
- Do not point the combustion air intake against the vehicle's airstream.
- The combustion air intake must not become clogged with dirt and snow.
- Install the combustion air system sloping slightly downwards. If necessary, make a drain hole approx. \varnothing 5 mm at the lowest point as a condensation outlet.
- In rail vehicles it is important to ensure that the combustion air opening does not point in one of the possible directions of travel (90° to the direction of travel).

Please note!

Comply with the regulations and safety instructions for this chapter given on page 4 – 7.

Combustion air intake

The combustion air is routed to the burner in the heater via the hood. No installation work is necessary. If the heater is installed in a box or the installation conditions are very constricted, we recommend fitting a hood with hose connection. The combustion air is then sucked in through a flexible hose. This ensures that the combustion air is sucked in from an area in the right temperature range which is protected from dirt. A safety grille is to be fitted to the flexible hose.

If a hood with hose connection is not used when the heater is installed in a box, the combustion air must be sucked in through a ventilation opening with an effective minimum cross section which corresponds to a pipe with \varnothing 60 mm.

Please note!

The ventilation opening for the combustion air must be positioned on the box so that it cannot become blocked by dirt and snow and exhaust gases cannot be sucked in.

Example for the combustion air system

Combustion air intake through a gill plate.

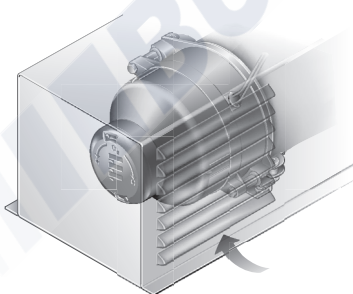

Combustion air intake with a flexible hose \varnothing 60 mm, max 1 m long.

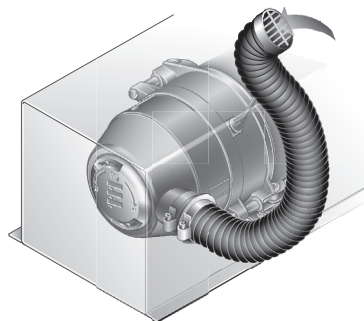



3 Installation

Connection to the cooling water circuit

The heater is integrated in the vehicle's cooling water circuit. An alternative installation option is to install the heater with its own cooling water circuit with a header tank.



Danger!

Risk of injuries and burns!

The cooling water and components of the cooling water circuit can get very hot.

- Parts conveying water must be routed and fastened in such a way that they pose no temperature risk to man, animals or material sensitive to temperature from radiation / direct contact.
- Before working on the cooling water circuit, switch the heater off and wait until all the components have cooled down completely, if necessary wear safety gloves.

Please note!

- When installing the heater, please note the direction of flow of the cooling water circuit.
- Fill the heater and water hoses with cooling water before connecting to the cooling water circuit.
- Route the water hoses without any kinks, and in a rising position if possible.
- When routing the water pipes, observe a sufficient clearance to hot vehicle parts.
- Protect all water hoses / water pipes from chafing and from extreme temperatures.

- Secure all hose connections with hose clips.
- After the vehicle has been operating for 2 hours or travelled 100 km, tighten the hose clips again.
- The minimum water flow rate is only guaranteed if the temperature difference of the heating medium does not exceed 10 K between water inlet and water outlet during heating.
- Only overpressure valves with an opening pressure of min. 0.4 – max. 2 bar may be used in the cooling water circuit.
- The cooling water must contain at least 10 % coolant (antifreeze) all year round as corrosion protection.
- During cold periods the coolant water must contain sufficient coolant (antifreeze).
- Before commissioning the heater for the first time or after changing the cooling water, the whole cooling water circuit including the heater must be vented without bubbles according to the vehicle manufacturer's instructions.
- Only top up with coolant approved by the vehicle manufacturer.
- Insert the water pump preferably in the water inlet line to the heater.

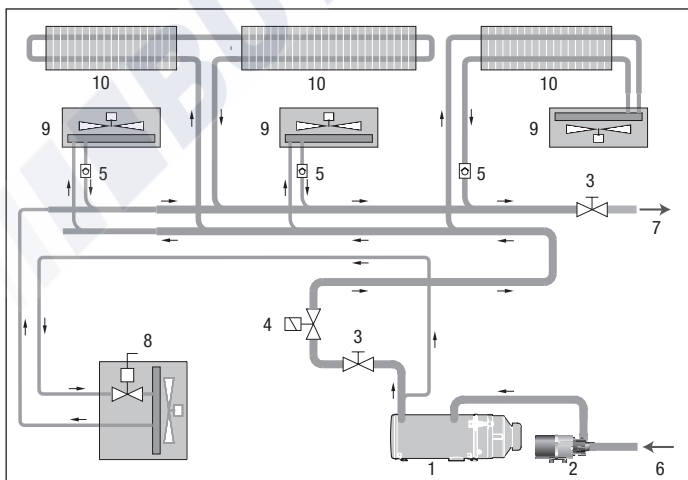

Water circuit

The diagram shows the heater integrated in the cooling water circuit of a bus or coach / rail vehicle.

- 1 Heater
- 2 FLOWTRONIC water pump
- 3 Shutoff valve
- 4 Electrical shutoff valve
- 5 Non-return valve
- 6 From vehicle engine or header tank
- 7 To the vehicle engine or header tank
- 8 Front heater / driver's cab
- 9 Space heater
- 10 Convection heater

3 Installation

Fuel supply

The following safety instructions must always be observed when laying the fuel lines and installing a fuel tank. Deviations from the instructions stated here are not allowed. Failure to comply can result in malfunctions.



Danger!

Risk of fire, explosion, poisoning and injuries!

Caution when handling fuel.

- Switch off the vehicle engine and the heater before refuelling and before working on the fuel supply.
- Avoid naked flames when handling fuel.
- Do not smoke.
- Do not inhale petrol fumes.
- Avoid any contact with the skin.



Important!

Safety instructions for laying the fuel pipes!

- Only use a sharp knife to trim the fuel hoses and pipes. Interfaces must not be crushed and must be free of burrs.
- The intake and return line must be filled with fuel when putting into service. The heater only works with vented pipes and lines (filter).
- Fuel pipes must be securely fixed to avoid any damage and / or noise due to vibrations (recommended guideline value: at spacings of approx. 50 cm).
- Fuel pipes must be protected against mechanical damage.
- Lay the fuel pipes so that any distortion or shaking of the vehicle, engine movements, etc. do not have a disadvantageous effect on the service life.
- Parts carrying fuel must be protected from disruptive heat.
- Never lay or fix the fuel pipes immediately next to the heater's exhaust system pipes or along the vehicle's exhaust system. If the systems cross, always ensure there is sufficient heat clearance. If necessary, install heat deflection plates.
- Dripping or evaporating fuel must never be allowed to collect on hot parts or ignite on electric equipment.
- When connecting fuel pipes with a fuel hose, always mount the

fuel pipes in a butt joint to prevent any bubbles from forming.

Safety instructions for fuel pipes and fuel tanks in buses and coaches

- In buses and coaches, fuel pipes and fuel tanks must not be routed through the passenger compartment or driver's cab.
- Fuel tanks in buses and coaches must be positioned in such a way that the exits are not in immediate danger if a fire occurs.

Please note!

Comply with the regulations and safety instructions for this chapter given on page 4 – 7.



3 Installation

Fuel supply

Fuel quality

The heater runs problem-free on standard commercial quality diesel fuel in accordance with DIN EN 590, which you use to run your vehicle engine.

Fuel for special cases

In special cases (above 0 °C), the heater can also run on fuel oil EL or paraffin.

Fuel for low temperatures

Refineries and petrol stations automatically adjust fuel to normal winter temperatures (winter diesel).

Therefore, difficulties can only occur if there are extreme drops in temperature, the same as applies to the vehicle engine. Please also refer to the vehicle manual.

If the heater is run from a separate tank, please comply with the following rules:

At temperatures above 0 °C, any kind of diesel fuel to DIN EN 590 can be used.

If no special diesel fuel is available for low temperatures, then paraffin or petrol should be mixed with the fuel according to the table below:

Please note!

- Additions of used oil are **not** allowed!
- After refuelling with winter or cold diesel or the listed blends, the fuel lines must be filled with the new fuel by letting the heater run for 15 mins.!

Operation with bio diesel (PME)

The heater is **not** approved for operation with biodiesel.

Temperature	Winter diesel fuel	or	Summer diesel fuel or heating oil EL	+	Admixture	
					Petroleum	Regular petrol (two-star petrol)
0 °C to -10 °C	100 %	or	70 %	+	30 %	or 30 %
-10 °C to -15 °C	100 %	or	50 %	+	50 %	---
-15 °C to -20 °C	70 %	---	---	+	30 %	or 30 %
-20 °C to -25 °C	50 %	---	---	+	50 %	---
-25 °C to -40 °C	100 % special cold diesel fuel (Arctic diesel)					

3 Installation

Fuel supply

Connection of the intake and return pipe to the heater

The fuel is taken from the vehicle fuel tank or a separate fuel tank.

Normal fuel hoses or pipes in vehicle engineering can be used e.g. pipes of steel, copper or plastic.

Fuel hoses and fuel pipes are available as accessory parts, see accessories catalogue.

Allowable dimensions of the fuel pipes

Inner diameter of the suction and return pipe:

- fore connection to the hose insert ring \varnothing 6 mm:
min. \varnothing 5 mm / max. \varnothing 6 mm,
- fore connection to the hose insert ring \varnothing 8 mm:
min. \varnothing 7 mm / max. \varnothing 8 mm.

Please note!

Fuel pipes with inner diameter \varnothing 7 mm / \varnothing 8 mm and hose insert rings with \varnothing 8 mm must be purchased separately from specialist dealers.

Permissible suction height and lengths of the suction line:

- Suction height up to 1.5 m \rightarrow max. length = 25 m
- Suction height 1.5 m to 4.0 m \rightarrow max. length = 15 m

Permissible length of the return line:

- max. length = 18 m

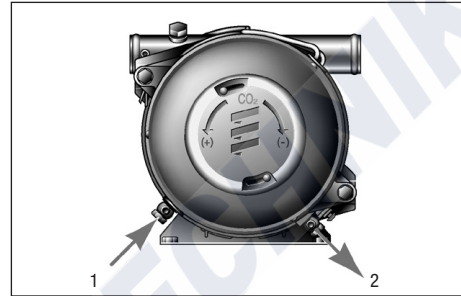

- 1 Connection of the suction pipe to the hose insert ring \varnothing 6 mm or \varnothing 8 mm
- 2 Connection of the return pipe to the hose insert ring \varnothing 6 mm or \varnothing 8 mm

Please note!

Please consult the manufacturer for operation in single line systems.

Functional performance of the heater depending on the fuel pressure

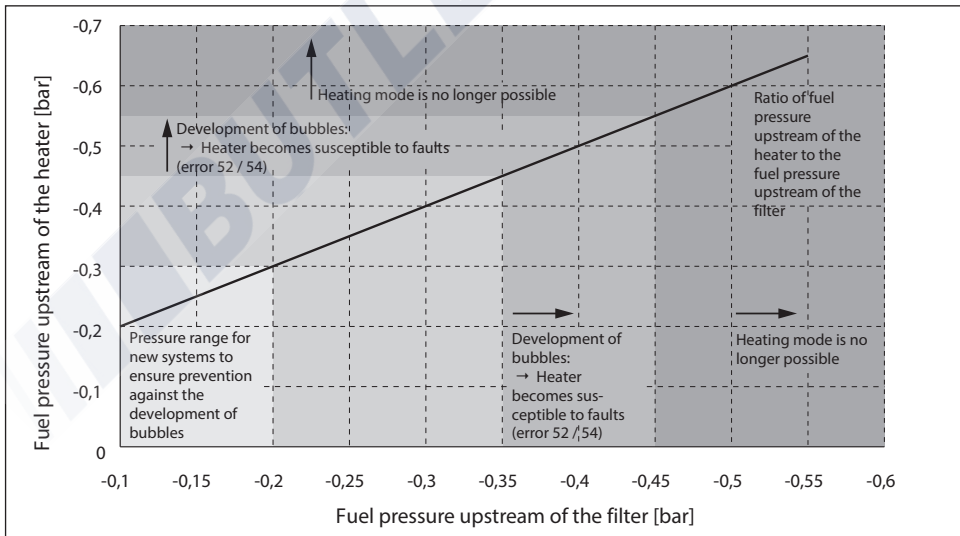

In order to ensure the fuel pump works, it is necessary to ensure that the underpressure in the fuel system is not too large (see diagram).



4 Operation and function

Structure of the heater

The heater consists of a heat exchanger and a removable burner. The heat exchanger contains a combustion chamber consisting of a header pipe with integrated mixer. The header pipe can be pulled out of the heat exchanger if necessary.

The control box and electric motor are fixed to the burner flange under the shroud of the burner. The fuel pump is integrated in the burner housing.

The following additional parts are required to run the heater:

- Water pump
- Additional parts for connection to the water circuit
- Additional parts for the fuel supply
- Additional parts for the exhaust system
- Control unit

For order No. of the additional parts see page 8, for further additional parts see additional parts catalogue.

Special features of the heater

- If the water flow is too low the water discharge temperature is limited by premature compensation.
- The time taken for the temperature rise in the heat distribution medium is monitored. If it rises too fast (water flow too low) the heater automatically switches "OFF" and begins with the after-running, the cycle then begins again.
- Constant comparison of the temperature sensor and overheating sensor measurements provides additional heater safety. If the difference between the measured values is too large (water flow too low) the heater prematurely switches "OFF".

Operating instructions

The heater is operated by a control unit. Detailed operating instructions are supplied with the control unit.

Please note!

You will be issued the operating instructions by the installation workshop.

Important instructions for operation

Safety checks before the start

After a lengthy stoppage (summer months), check all components for secure fit (tighten screws where necessary). Carry out a visual check of the fuel system for leaks.

Before switching on

Before switching on or pre-programming heating mode, switch the vehicle's heating lever to "WARM" (maximum setting) and the blower to "slow level" (low electricity consumption). In vehicles with automatic heating, before switching off the ignition, switch the heating lever to "MAX" and the required damper position to "OPEN".

Heating at high altitudes

When using the heater at high altitudes, please note:

- Heating at altitudes up to 1500 m:
 - Unlimited heating possible.
- Heating at altitudes over 1500 m:
 - You can use the heater at this altitude for short periods (e.g. driving through a mountain pass or taking a break in your journey).
 - For longer stays it is necessary to adjust the level of the fuel supply, please contact a JE partner for further details and advice.

Initial commissioning of the heater

The following points are to be checked by the company installing the heater during initial commissioning.

- After installation of the heater, the coolant circuit and the whole fuel supply system must be vented carefully. Comply with the instructions issued by the vehicle manufacturer.
- Open the coolant circuit before the trial run (set the temperature control to "WARM").
- During the heater trial run, all water and fuel connections must be checked for leaks and secure, tight fit.
- If faults occur while the heater is running, use a diagnostic unit to determine and correct the cause of the fault.

4 Operation and function

Functional description

Switch on the heater

When the heater is switched on a component test is performed (3 seconds), the water pump is then started up.

Note:

If the water temperature is $< 5\text{ }^{\circ}\text{C}$ the nozzle pre-heating is switched on for 60 seconds, the burner start is delayed by this time.

Burner start

The electric motor starts and drives the combustion air impeller and the fuel pump.

After approx 10 seconds the ignition is switched on and then the fuel solenoid valve opens. Within these 10 seconds a rotary check is performed on the electric motor. The fuel and combustion air in the combustion chamber form an ignitable mixture. The mixture is ignited by a high-voltage ignition spark. The flame monitor recognises the flame's flicker frequency and switches off the ignition spark generator. The hot combustion gases flow through the heat exchanger and transfer the heat to the heat distribution medium.

Please note!

- The heater operates depending on the heat requirements, this means the burner's switching on and switching off times vary.
- The water pump remains in service the whole time the heater is running, even during pause mode and during after-running.

Options

- If temperature lowering is activated the "ON / OFF" control temperatures are lowered by approx 8K.
Connection of the ON / OFF switch for temperature lowering, see circuit diagram on page 28.
- The water pump can be run independently of the heater if appropriate controls are installed. For connection of the additional "ON / OFF" switch for separate water pump control, see circuit diagram on page 28.
- With control of the vehicle's blower, the vehicle blower is switched on or off at the following water temperatures.
 - Water temperature $> 55\text{ }^{\circ}\text{C}$
—>Vehicle blower "ON"
 - Water temperature $< 50\text{ }^{\circ}\text{C}$
—>Vehicle blower "OFF"

For control of the vehicle's blower, see circuit diagram on page 28.

Switch off the heater

If the heater is switched off the fuel solenoid valve closes and after-running simultaneously starts for approx 3 minutes. After the after-running has finished the heater is automatically switched off.

Please note!

Until it is switched off, including during the after-running, the fuel is circulated.



4 Operation and function

Control and safety devices

The heater is equipped with the following control and safety devices.

- If the heater does not ignite the control box* is locked after an unpermissible number of unsuccessful start attempts.
- If the water flow is too low the water discharge temperature is limited by premature compensation.
- The time taken for the temperature rise in the heat distribution medium is monitored. If it rises too fast (water flow too low) the heater automatically switches "OFF" and begins with the after-running, the cycle then begins again.
- Constant comparison of the temperature sensor and overheating sensor measured values provides additional heater safety, because if the difference between the measured values is too large (water flow too low) the heater is prematurely switched off (shut-down on fault).
After an impermissible number of shut-downs on fault, the control box is locked.*
- If the lower or upper voltage limit is reached, the heater is automatically switched off.
- If the flame sensor detects a flame during the heater's after-running the heater is automatically switched off.
After an impermissible number of shut-downs on fault, the control box is locked.*

* The lock can be cancelled and faults read out:

- with the modular timer / EasyStart T timer
- with the radio remote control TP5 / EasyStart R+.

For other control units by connecting:

- the diagnostic unit
- the customer service program KD2000 / EDITH.

For operation and fault list, please refer to the enclosed operating instructions or the troubleshooting and repair instructions for the heater.

Emergency stop – EMERGENCY OFF

If an emergency stop – EMERGENCY OFF – is necessary during operation, proceed as follows:

- Switch the heater off at the control unit or
- pull the fuse out or
- disconnect the heater from the battery.

5 Electrical system

Heater wiring



Important! **Safety instructions!**

The heater is to be connected up electrically according to the EMC directives. Improper tampering with the heater can affect the EMC. For this reason, comply with the following instructions:

- Ensure that the insulation of electrical cables is not damaged. Avoid: Chafing, kinking, jamming or exposure to heat.
- Seal any connection chambers of waterproof connectors not in use with filler plugs to ensure they are dirt-proof and water-proof.
- Electrical connectors and earth connections must be free of corrosion and securely connected.
- Lubricate connections and ground connections outside the heater interior with contact grease.

Please note!

Comply with the following when wiring the heater and the control unit:

- Electrical leads, switch and control gear must be positioned in the vehicle so that they can function perfectly under normal operating conditions without impairment (e.g. due to heat exposure, moisture, etc.).
- The following cable cross-sections are to be used between the battery and heater. This ensures that the max. permissible voltage drop in the cables does not exceed 0.5 V for 12 V or 1 V for 24 V rated voltage.
Cable cross-sections for a cable length (plus cable + minus cable) of:
 - up to 5 m = cable cross-section 4 mm²
 - from 5 m to 8 m = cable cross-section 6 mm²
- If the positive cable is to be connected to the fuse box (e.g. terminal 30), the vehicle's cable from the battery to the fuse box must also be included in the calculation for the total cable length and re-dimensioned if necessary.
- Insulate unused cable ends.



5 Electrical system

Heater circuit diagram – Part 1

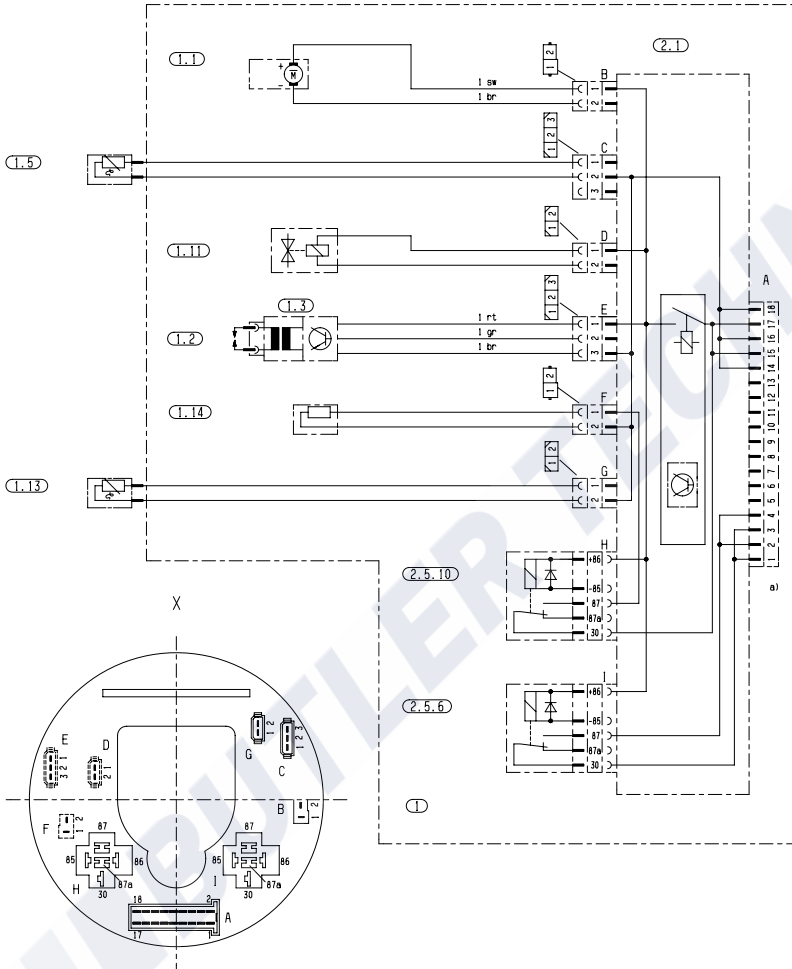

25 1818 00 96 01 D

Parts list

- | | | | |
|-------|---------------------------------------|--------|--|
| 1 | Heater | 2.1 | Control box |
| 1.1 | Burner motor | 2.5.6 | Relay, water pump |
| 1.2 | Ignition electrodes | 2.5.10 | Relay, heating cartridge |
| 1.3 | Ignition spark generator | a) | Connection, control unit |
| 1.5 | Overheating sensor | X | Graphic illustration of the control box from the impeller side |
| 1.1.1 | Fuel solenoid valve | | |
| 1.1.3 | Sensor, control temperature, interior | | |
| 1.1.4 | Heating element for fuel nozzle | | |

Connectors and bush housings are shown from the cable inlet side.

5 Electrical system

Heater circuit diagram – Part 2

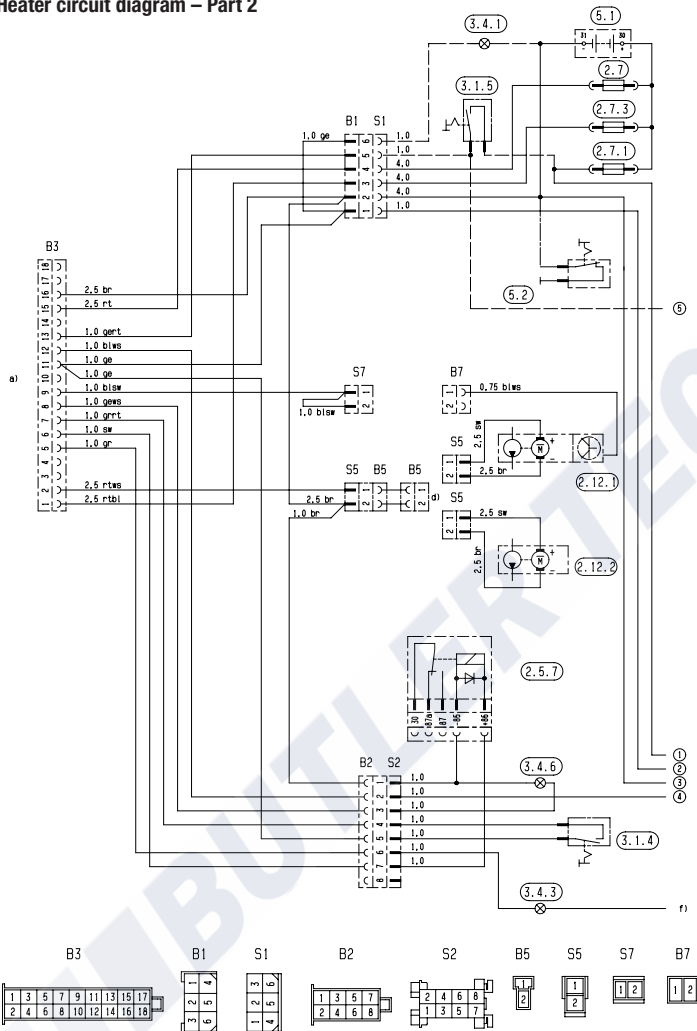

Parts list

- 2.5.7 Relay for control (vehicle blower)
- 2.7 Main fuse 15 A
- 2.7.1 Fuse, actuation 5 A
- 2.7.3 Fuse, water pump 15 A
- 2.12.1 Water pump, FLOWTRONIC 6000S
- 2.12.2 Water pump, FLOWTRONIC 5000 / 5000S
- 3.1.4 Switch, temperature lowering
- 3.1.5 Switch, water pump
- 3.4.1 Switch on control

- 3.4.3 Fault indicator lamp
- 3.4.6 Fuel indicator lamp
- 5.1 Battery
- 5.2 Battery isolating switch

- a) Heater connection
- d) Optionally 2.12.1 or 2.12.2
- f) If using 3.2.6 optionally terminal 15 or terminal 30 – otherwise switch on positive (cable 1² yellow)

25 1818 00 97 01 F



5 Electrical system

Circuit diagram for control units

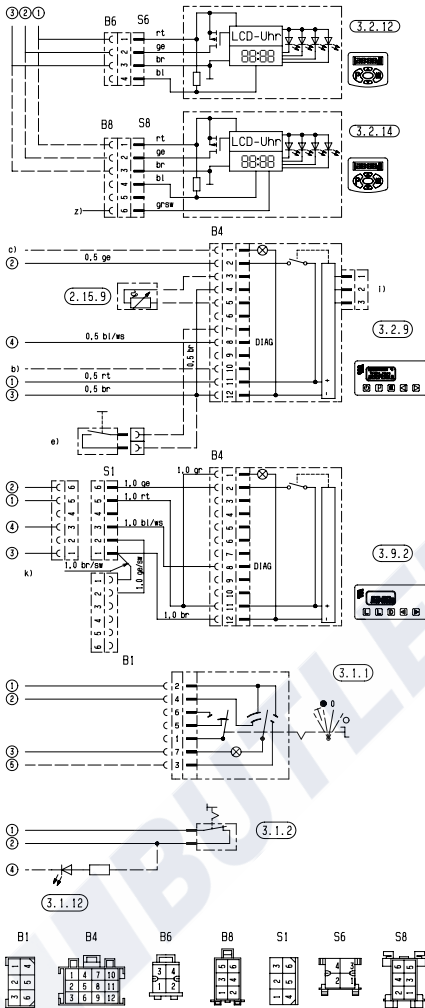

25 1818 00 97 01 F

Parts list

- 2.15.9 Temperature sensor (outside temperature)
- 3.1.1 Universal switch
- 3.1.2 Switch, heat, continuous operation
- 3.1.12 Fault code query
- 3.2.9 Module timer
- 3.2.12 Timer, mini (12 / 24 volt)
- 3.2.14 Timer, mini lighting (12 / 24 volt)
- 3.9.2 Diagnostic unit

- b) Connect to +15
- c) Lighting, terminal 58
- e) External "ON / OFF" button (option)
- i) Connection, radio module
- k) Not included in the scope of supply of 3.9.2
- z) Terminal 58 (lighting)

Insulate unused cable ends.

Connectors and bush housings are shown from the cable inlet side.

5 Electrical system

Parts list for circuit diagram, EasyStart control units

- 2.15.1 Temperature sensor (room temperature)
(with EasyStart R+ included in scope of supply,
with EasyStart T and EasyStart R optional)
- 2.15.9 Temperature sensor (outside temperature)
(optional)
- 3.1.7 "OFF" button
- 3.1.9 "Heat / ventilate" switch
(with EasyStart T included in scope of supply,
with EasyStart R optional)
- 3.1.16 Radio remote control button
- 3.2.15 Timer, **EasyStart T**
- 3.3.9 Radio remote control, **EasyStart R**
(stationary unit)
- 3.3.10 Radio remote control, **EasyStart R+**
(stationary unit)
- 3.6.1 Lead harness
- 3.8.3 Antenna

- c) Terminal 58 (lighting)
- d) Parking / cab ventilation with vehicle blower (optional)
- e) Connection, EasyStart T timer
- g) External "ON / OFF" button (optional)

Cable colours circuit diagrams

- sw = black
- ws = white
- rt = red
- ge = yellow
- gn = green
- vi = violet
- br = brown
- gr = grey
- bl = blue
- li = purple

Connectors and bush housings are shown from the cable inlet side.

Please note!

For circuit diagrams, see page 31 – 33.



5 Electrical system

Circuit diagram, EasyStart R control units

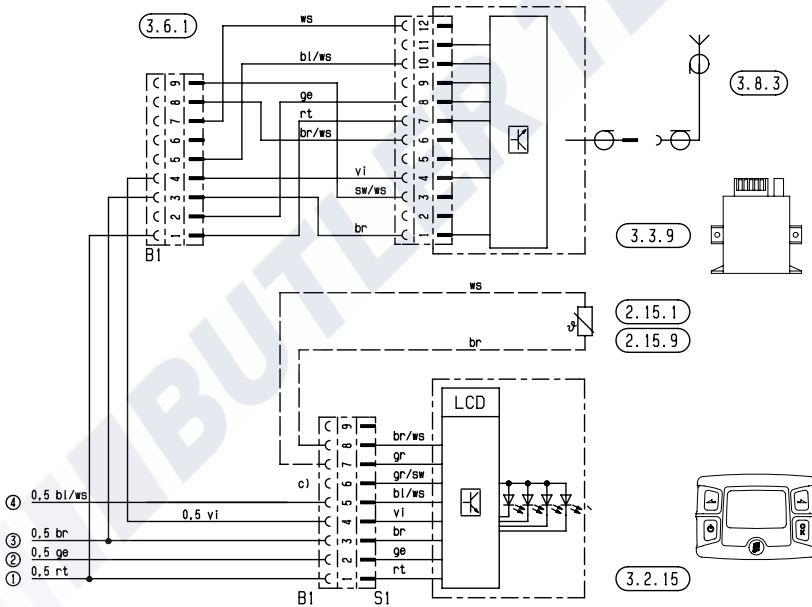
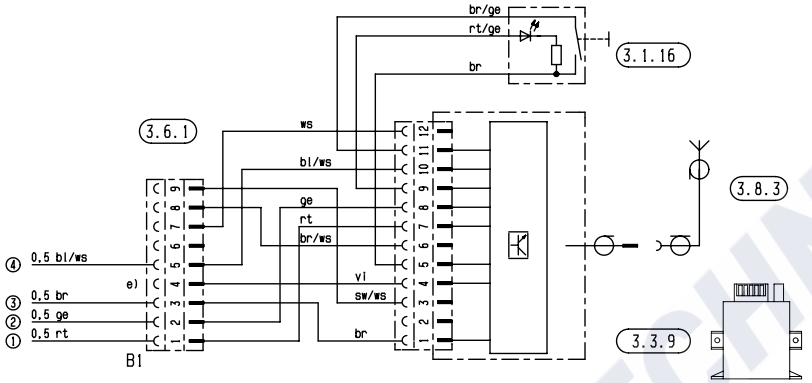

B1

S1



5 Electrical system

Circuit diagram, EasyStart R+ control units

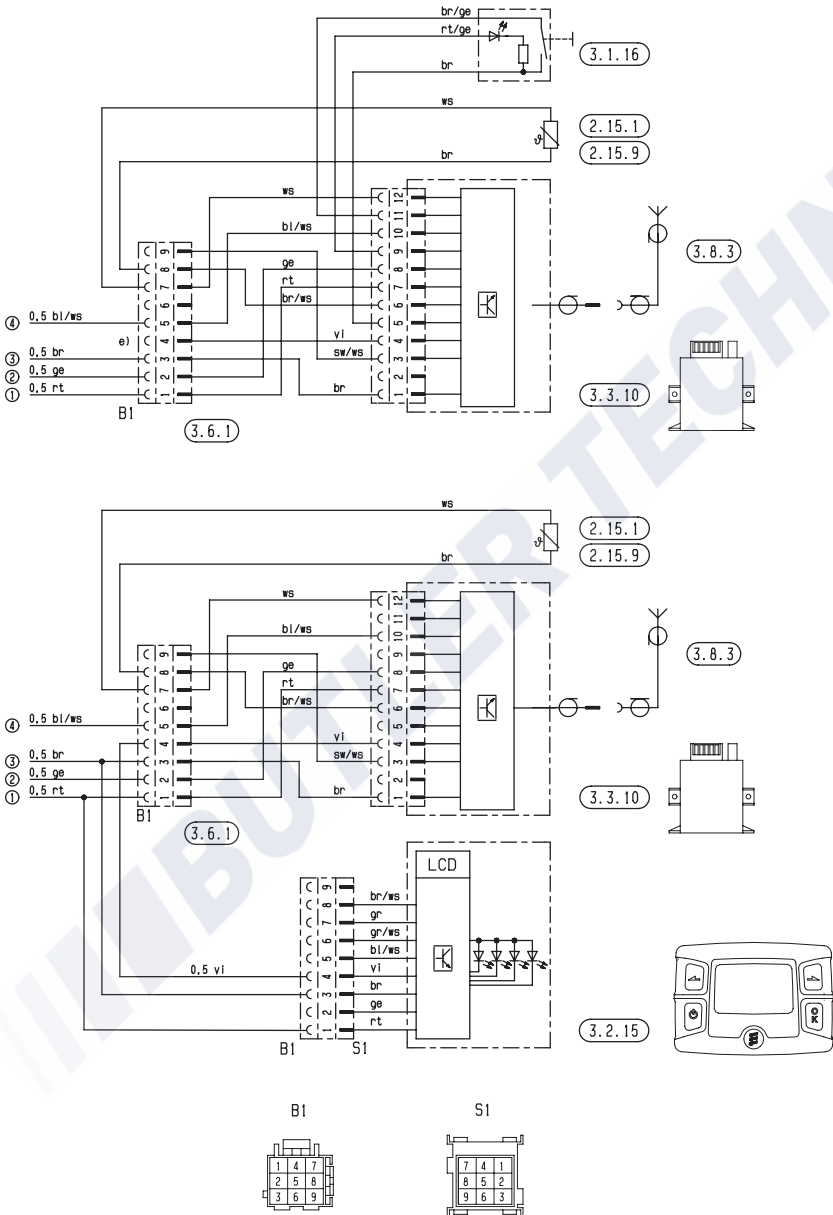



5 Electrical system

Circuit diagram, EasyStart T control units

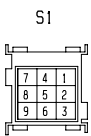
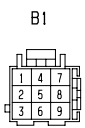
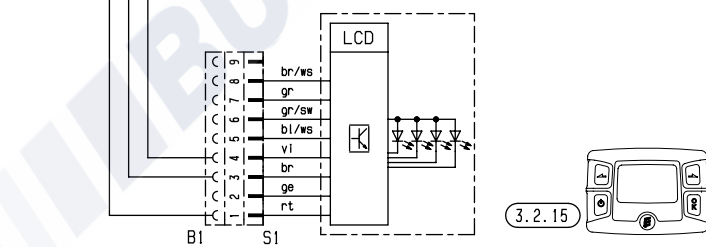
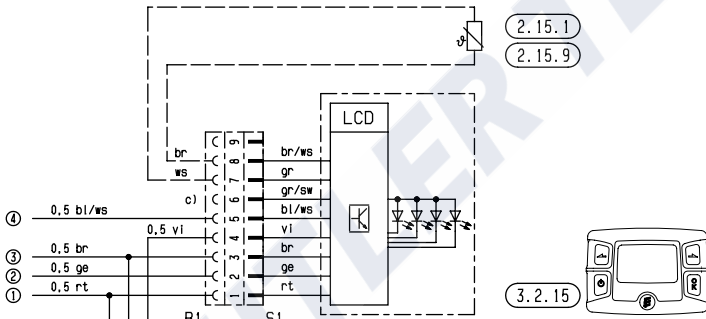
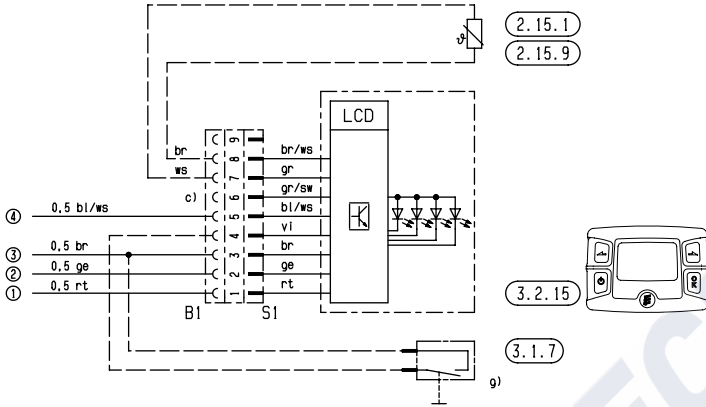

6 Troubleshooting / maintenance / service

If any faults occur, please check the following items

- If the heater does not start after being switched on:
 - Switch the heater off and on again.
- If the heater still does not start, check whether:
 - Fuel in the tank?
 - The fuses are ok?
 - The electrical cables, connections, terminals, are ok?
 - Anything is clogging the combustion air supply or exhaust system?
 - Fuel supply ok?

Troubleshooting

If, after checking these items, the heater is still faulty or another malfunction occurs in your heater, please contact:

- If factory-installed, your contract workshop / garage.
- If subsequently installed, the workshop / garage which installed the heater.

Please note!

Please note that guarantee claims can expire if the heater is modified by a third party or if non-original parts are installed.

Maintenance instructions

- Switch the heater off once a month for about 10 minutes, even outside the heating period.
- Before the heating period starts, a trial run should be carried out for the heater. If thick, persistent smoke develops, unusual burning noises or a clear fuel smell occurs or if electric / electronic parts overheat, the heater must be switched off and put out of service by removing the fuse.
In this case, the heater should not be started up again until it has been checked by qualified staff who have been trained on Eberspächer heaters.
- Check the openings of the combustion air supply and exhaust system after longer standstill periods, clean if necessary!

Initial commissioning

The following points are to be checked by the company installing the heater during initial commissioning.

- After installation of the heater, the coolant circuit and the whole fuel supply system must be vented carefully. Comply with the instructions issued by the vehicle manufacturer.
- Open the cooling water circuit before the trial run (set the temperature control to "WARM").
- During the heater trial run, all water and fuel connections must be checked for leaks and secure, tight fit.
- If faults occur while the heater is running, use a diagnostic unit to determine and correct the cause of the fault.

Changing components

The components listed below must be exchanged at the end of the given operating period:

- Heat exchanger after 5000 operating hours,
- Burner after 3000 operating hours,
- Nozzle after 600 operating hours or at least once per year.

Service

If you have any technical queries or problems with your pre-heater, dial the following service phone number from within Germany:

Hotline
Phone +49 (0) 800 / 12 34 300

Fax hotline
Phone +49 (0) 1805 / 26 26 24

Outside of Germany, please contact the respective Eberspächer national representative.



7 Environment

Certifications

The high quality of Eberspächer's products is the key to our success.

To guarantee this quality, we have organised all work processes in the company along the lines of quality management (QM). Even so, we still pursue a large number of activities for continuous improvement of product quality in order to keep pace with the similarly constantly growing requirements made by our customers.

All the steps necessary for quality assurance are stipulated in international standards. This quality is to be considered in a total sense.

It affects products, procedures and customer / supplier relationships.

Officially approved experts assess the system and the corresponding certification company awards a certificate.

Eberspächer has already qualified for the following standards:

**Quality management in accordance with
DIN EN ISO 9001:2000 and ISO/TS 16949:1999**

**Environmental management system in accordance with DIN
EN ISO 14001:1996**

Disposal

Disposal of materials

Old devices, defective components and packaging materials can all be separated and sorted into pure-grade fractions, if necessary, so that all parts can be disposed of in an environment-friendly way or the materials recycled. Electric motors, control boxes and sensors (e.g. temperature sensors) are deemed to be "electronic scrap".

Dismantling the heater

The heater is dismantled according to the repair stages in the current troubleshooting / repair instructions.

Packaging

The heater's packaging can be kept in case it has to be sent back.

EC Declaration of Conformity

With regard to the following products

Heater type HYDRONIC L

we herewith confirm that it conforms with the prime safety requirements stipulated in the directives of the EU Council for harmonisation of the legal regulations of the member states with regard to electromagnetic compatibility (89 / 336 / EEC).

This declaration applies to all heaters produced according to the production drawings HYDRONIC L which are an integral part of this declaration.

The following standards / directives have been used to assess the product with regard to electromagnetic compatibility:

- EN 50081 – 1 Basic form interference emission
- EN 50082 – 1 Basic form of interference immunity
- 72 / 245 / EEC – Modification status 2005 / 83 / EC interference suppression in motor vehicles.

UKCA Declaration of Conformity

We herewith declare that the version of the heater placed on the market by us conforms to the applicable provisions of the following UK Directive.

Electromagnetic Compatibility, Statutory Instrument 2016, No. 1091



The full Declaration of Conformity can be viewed and downloaded from the download centre at www.eberspaecher.com.

6 Lists

List of key words A – Z

Key word	Page	Key word	Page
A			
Accident prevention	7	M	
Altitude	23	Main dimensions	12
Ambient temperature	10, 11	Maintenance	34
C			
Cable colours	31	Materials	35
Cable lengths	22	Mounting positions	13
Certification	35	N	
Changing components	34	Nameplate	15
Circuit diagrams	27 – 33	Notes	4, 5
Combustion air system	18	O	
Concept of this manual	3	Operating instructions	23
Connection, water cooling circuit	19	Operation	23 – 25
Contents	2	P	
Control devices	25	Picture symbols	4
Cooling water circuit	19	Position of the heater	5
D			
Declaration of conformity	35	Power consumption	10, 11
Disposal	35	R	
E			
EC Declaration of Conformity	35	Rated voltage	10, 11
Electrical system	26 – 33	Regulations	5, 6
Emergency off	25	Representations	4
Environment	35	S	
Exhaust system (pipes)	16	Safety devices	25
Exhaust system	5	Scope of supply	8 – 11
F			
Fixing	13	Special text formats	4
Fuel quality	21	Start procedure	24
Fuel supply	20 – 22	Statutory regulations	5, 6
Fuel supply	5	Storage temperature	10, 11
Functional description	24	Suction head	22
H			
Heat flow	10	Switching on	24
Heating mode	23	T	
Hotline	34	Technical data	10, 11
I			
Information	4	Test mark	5
Initial commissioning	23	Text structure	4
Installation location	14, 15	Troubleshooting	34
Intended use	4	V	
Interference suppression	10, 11	Voltage limit	10, 11
Introduction	2	Voltage	10, 11
L			
List of abbreviations	37	W	
		Weight	10, 11
		Wiring	26



6 Lists

List of abbreviations

ADR

European agreement about the international transport of dangerous goods on the road.

EC type-approval

Permit awarded by the Federal Vehicle Office for the production of a heater for installation in motorised vehicles.

EMC Directive

Electromagnetic compatibility.

JE-partner

Eberspächer partner.

PME

Biodiesel according to DIN V 51606.



BUTLER TECHNIK

/// BUTLER TECHNIK

www.eberspaecher.com

Eberspacher (UK) Ltd.
Climate House, Yeoman Road
Ringwood, Hampshire BH24 3FA
enquiries@eberspaecher.com
www.eberspaecher.co.uk

Eberspacher Climate Control
Systems GmbH
Eberspacherstr. 24
73730 Esslingen
Germany
info@eberspaecher.com
www.eberspaecher.com



Eberspacher