



Water heater B 7 W/D 7 W

Troubleshooting and Repair Manual

J. Eberspächer
Eberspächerstr. 24
D-73730 Esslingen

Telefon (zentral)
(07 11) 9 39-00
Telefax
(07 11) 9 39-05 00

Valid for heater versions

B 7 W

20 1673 05 00 00 – 12 Volt

D 7 W

25 1666 05 00 00 – 12 Volt 25 1807 05 00 00 – 12 Volt

25 1667 05 00 00 – 24 Volt

Contents

	page	
In the event of faults, first check the following points.....	2	New features in version 25 1807 05 00 00 – 12 Volt
Function and fault test.....	2 – 8	• flame control PT 1000 in exhaust fitting
Control in heating operation.....	9	• new control unit
Function sequence.....	10	• spring-loaded overheating switch
Wiring diagrams.....	11 – 14	• wiring diagram page 13, 14
Repair instructions.....	15 – 21	
Measuring the fuel quantity	21, 22	

In the event of faults, first check the following points:

- Fuel in the tank?
- Heater lever (water valve) properly in the „WARM“ position?
- Fuses OK?
- Electrical lines, connectors, connections OK?
- Clogged combustion air line or exhaust line?
- Is the water pump running?

If not – check whether there is voltage at the motor?
if so – replace the water pump
if not – replace the control unit

- Has the overheating switch triggered?

Press the middle raised knob of the rubber cover to unlock the overheating switch located below.

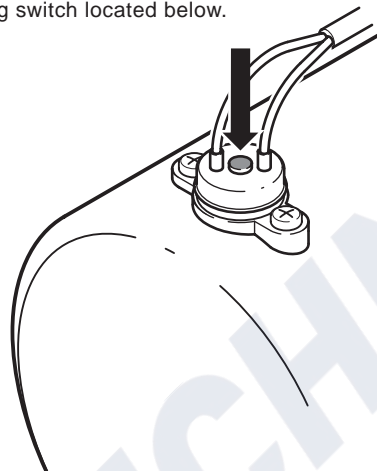

Function and fault test

for 20 1673 05 00 00 – 12 Volt
25 1666 05 00 00 – 12 Volt
25 1667 05 00 00 – 24 Volt

Does the function and fault display (flashing code) integrated in the heating switch indicate a fault?

Identify the signal (flashing code) and rectify the fault according to the function and fault test, page 3 – 5.

If the operating element does not have a fault indicator, an indicator is then fitted to the control unit at the „Test/S“ connection. An LED or an acoustic signal transmitter can be used as the indicator.

Once the heater has been switched on, the indicator will show the signals.

See the function and fault Test on pages 3 – 5 for identifying the signal (flashing code) and remedying the trouble.

for 25 1807 05 00 00 – 12 Volt

Does the function and fault display (flashing code) integrated in the heating switch indicate a fault?

Identify the signal (flashing code) and rectify the fault according to the function and fault test, page 6 – 8.

A diagnosis unit (order no. 22 1512 89 00 00) can be connected up instead of the timer (3.2.5 in wiring diagram) to indicate possible faults.

For instructions, please refer to the operating manual for the diagnosis unit. Troubleshooting (fault list and fault rectification) see function and fault test page 6 – 8.



If the fault is not recognized by the control unit, see page 5 of the function and fault test.



**Function and fault test for unit B 7 W 20 1673 05 00 00 – 12 Volt,
D 7 W 25 1666 05 00 00 – 12 Volt and 25 1667 05 00 00 – 24 Volt**

Fault description	Indication		Cause	Remedy
	Signal	Seconds		
Start, heating phase (trouble-free operation)				
Normal operation (trouble-free operation)				
Delayed shut-off, restart (heater still not shut off or in the control interval when started)			Heater still not shut off Water temperature still above the triggering point for the temperature sensor (approx. 80 °C) Temperature sensor interruption	Wait until end of delayed shut-off Wait until temperature falls below the triggering point Replace temperature sensor
Warning: power supply (undervoltage or overvoltage)			Undervoltage Overvoltage	Charge battery Check regulator
Overheat (automatic cutout)			Electric line to metering pump interrupted Insufficient cooling water Water circuit not properly bled Water pump defective	Check line Top up cooling water Bleed water circuit Replace water pump Operate safety thermal cutout switch
Flame sensor defective (short-circuit)			Flame sensor defective	Replace flame sensor
Flame out L o w (flame goes out by itself in „Low“ setting)			Insufficient fuel Speed of blower not reduced Vapour lock in the fuel line? Control unit defective Flame sensor fouled/defective	Measure fuel quantity Replace partial-load resistor Re-route line Replace control unit Clean/replace flame sensor
Flame out H i g h (flame goes out by itself in „High“ setting)			Insufficient fuel Vapour lock in the fuel line? Flame sensor fouled/defective	Measure fuel quantity Fuel line becomes too hot – re-route line Clean/replace fuel sensor

Function and fault test for unit B 7 W 20 1673 05 00 00 – 12 Volt,
D 7 W 25 1666 05 00 00 – 12 Volt and 25 1667 05 00 00 – 24 Volt

Fault description	Indication		Cause	Remedy
	Signal	Seconds		
Glow plug defective			Glow plug fuse defective Glow plug defective Flame sensor fouled/defective	Replace fuse Replace glow plug Clean/replace flame sensor
Burner motor defective			Heater fuse defective Electric motor defective or blower blocked Flame sensor fouled/defective	Replace fuse Replace blower Clean/replace flame sensor
Cutout due to undervoltage			Undervoltage Corrosion on electrical connections	Charge battery, check battery Clean electrical connections
Cutout due to overvoltage			Overvoltage	Check regulator Connect heater to battery
Non - start Safety time exceeded and automatic cutout			No fuel Metering pump defective Short-circuit at metering pump No pulses at metering pump Fuel line not filled Insufficient fuel Glow plug defective Automatic cutout after 3 – 5 mins. Flame sensor wrongly poled Flame sensor fouled Flame sensor interruption Insufficient fuel	Replace metering pump Check plug Replace control unit Restart, check fuel line Measure fuel quantity Replace glow plug Check connection against wiring diagram Clean flame sensor Replace flame sensor Measure fuel quantity



**Function and fault test for unit B 7 W 20 1673 05 00 00 – 12 Volt,
D 7 W 25 1666 05 00 00 – 12 Volt and 25 1667 05 00 00 – 24 Volt**

Indication	Cause	Remedy
<p>Faults not shown by the indicator:</p>		
<p>Sooty combustion</p>	<p>Combustion air line/exhaust line clogged Metering pump conveying too much Combustion air blower speed too low Deposits in heat exchanger</p>	<p>Remove clog Measure fuel quantity Replace blower Remove and clean heat exchanger</p>
<p>Heater does not regulate in „Low“ setting No warm air in interior</p>	<p>Temperature sensor short-circuited (vehicle blower does not switch on above approx. 55°C water temperature) Heater lever closed Vehicle blower not switched on Vehicle blower relay defective Vehicle blower fuse defective</p>	<p>Remove temperature sensor Open heater lever Switch on vehicle blower Replace relay Replace fuse</p>

**Function and fault test for unit D 7 W 25 1807 05 00 00 – 12 Volt
(Control unit 25 1732 50 00 04 0C)**

		Indication								Remedy		
Fault code	Fault description	Fault signal / flashing code										
		0	1	2	3	4	5	6	7	8	Seconds	
000	No fault	[Solid bar from 0 to 8]										
001	Pre-heating, overvoltage	[Bar 0-1]	[Bar 1-2]	[Solid bar from 2 to 8]								
002	Pre-heating, undervoltage	[Bar 0-1]	[Bar 1-2]	[Solid bar from 2 to 8]								
010	Overvoltage switch-off	[Bar 0-1]	[Bar 1-2]	[Bar 2-3]	[Bar 3-4]							
011	Undervoltage switch-off	[Bar 0-1]	[Bar 1-2]	[Bar 2-3]								
012	Overheating	[Bar 0-1]	[Bar 1-2]	[Bar 2-3]	[Bar 3-4]	[Bar 4-5]	[Bar 5-6]	[Bar 6-7]	[Bar 7-8]			
013	Temperature at heat exchanger to high	[Bar 0-1]	[Bar 1-2]	[Bar 2-3]	[Bar 3-4]	[Bar 4-5]	[Bar 5-6]	[Bar 6-7]	[Bar 7-8]			
020	Glow plug defect	[Bar 0-1]	[Bar 1-2]	[Bar 2-3]								
022	Short circuit in current regulator contacts	[Bar 0-1]	[Bar 1-2]	[Bar 2-3]								
023	Interruption in current regulator	[Bar 0-1]	[Bar 1-2]	[Bar 2-3]								
024	Short circuit in current regulator coil	[Bar 0-1]	[Bar 1-2]	[Bar 2-3]	[Bar 3-4]	[Bar 4-5]	[Bar 5-6]	[Bar 6-7]	[Bar 7-8]			



**Function and fault test for unit D 7 W 25 1807 05 00 00 – 12 Volt
(Control unit 25 1732 50 00 04 0C)**

		Indication								Remedy	
Fault code	Fault description	0	1	2	3	4	5	6	7		8
025	Short circuit at diagnosis output					No flashing code					Check diagnosis lead (connection A1 at control unit). Check connection to control unit.
030											
031	Combustion air fan does not rotate	█									Check combustion air fan. Check motor speed relay (2.5.8). Check connection to control unit (connections A11 and B1).
032											
033											
037	Water pump does not rotate	█	█	█	█	█					Check water pump (external triggering). Check connections to control unit (connections A11 and A13).
047	Short circuit in metering pump	█	█	█	█	█					Check metering pump. Check connections to control unit (connections A10 and B10).
051	Flame sensor defect	█									Temperature at flame sensor does not fall below 80 °C (corresponding to 1300 Ω). Check flame sensor or combustion, possibly replace. (Setpoints: 900 Ω to -25 °C, 1100 Ω to +25 °C).
052	Failure to start/safety time expired	█	█	█	█	█					See D 9 W
053	Flame abort in "large" stage	█	█	█	█	█					See D 9 W
055	Flame abort in "small" stage	█	█	█	█	█					See D 9 W
059	as D 9 W										See D 9 W

**Function and fault test for unit D 7 W 25 1807 05 00 00 – 12 Volt
(Control unit 25 1732 50 00 04 0C)**

		Indication								Remedy		
Fault code	Fault description	0	1	2	3	4	5	6	7		8	
060	Interruption in temperature sensor											Measured temperature lies outside measuring range. Check sensor. (Setpoints: 650 Ω at -25 °C, 1000 Ω at +25 °C). Check connections to control unit (connections A5 and A6).
061	Short circuit in temperature sensor											
064	Interruption in flame sensor											Measured temperature lies outside measuring range. Check sensor. (Setpoints: 900 Ω at -25 °C, 1100 Ω at +25 °C). Check connections to control unit (connections A4 and A5).
065	Short circuit in temperature sensor											
090	Control unit defect (internal reset)											Replace control unit.
092	ROM fault											
093	RAM fault											
094	EEPROM fault											
095	Control unit defect (general fault)											
096	Control unit defect (general fault)											
097	Control unit defect or cable harness fault											Check and where necessary replace control unit. Check cable harness.
091	External interference voltage											Check voltage supply. Check connection to control unit (connections A12 and B12).

For faults not shown here, please see page 5



Control in heating operation

CONTROL DIAGRAM

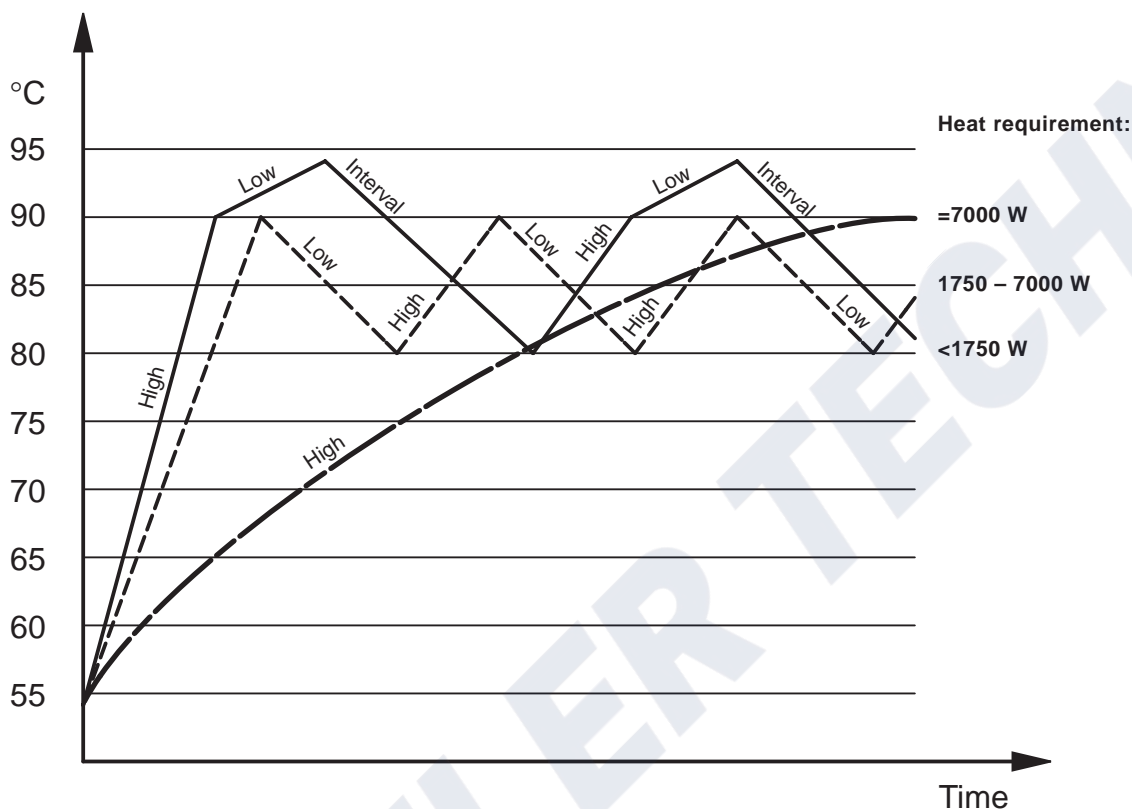

If the heater has ignited properly and is heating without trouble, the temperature sensor switches on the vehicle blower when the cooling water temperature is approx. 55 °C.

Various operating conditions can now result in the heating circuit depending on the heat requirement.

Heat requirement 7000 W

If the heat requirement is 7000 W and more, the heater always operates in the „High” setting.
The cooling water temperature rises to a approx. 90 °C.

Heat requirement 1750 W to 7000 W

After switch-on, the heater operates in the „High” setting.
When a cooling water temperature of approx. 90 °C is reached, the heater switches to the „Low” setting.
Since the heat requirement is greater than 1750 W the cooling water temperature drops.
When approx. 80 °C is reached the heater switches back to the „High” setting.

Heat requirement less than 1750 W

After switch-on, the heater operates in the „High” setting.

When a cooling water temperature of approx. 90 °C is reached, the heater switches to the „Low” setting.
The temperature continues to rise due to the low heat requirement.
At approx. 94 °C the heater starts with delayed shut-off operation and cuts out after approx. 120 seconds.

The water pump and the vehicle blower remain in operation during the delayed shut-off and the control interval. The pilot light stays on.

Once the coolant has cooled down to approx. 80 °C, the heater restarts in the „High” setting.

Function sequence „Starting and control operation”

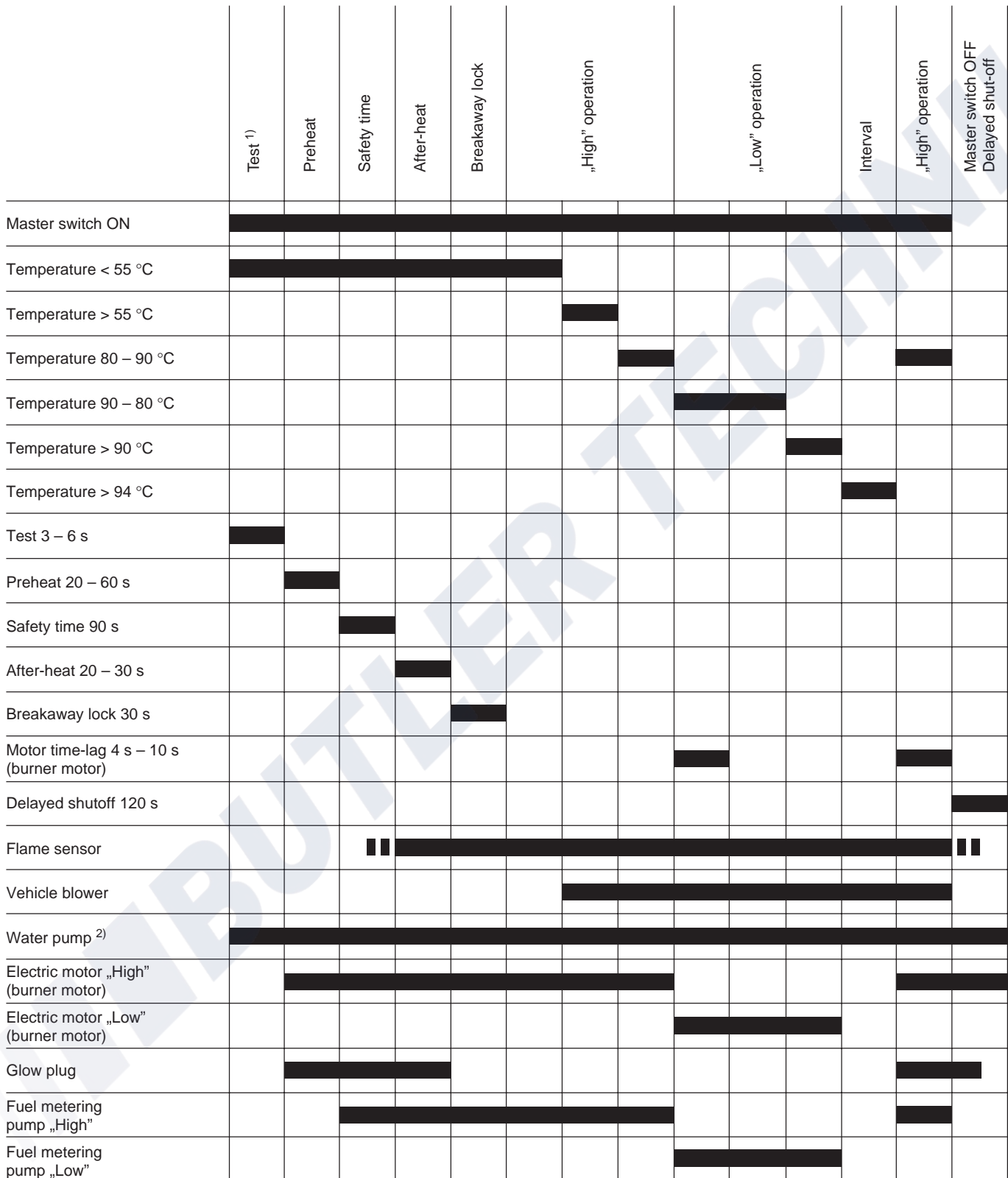

¹⁾ not for unit 25 1807 05 00 00

²⁾ for unit 25 1807 05 00 00: no water pump during test



Wiring diagram for units B 7 W 20 1673 05 00 00 – 12 Volt and D 7 W 25 1666 05 00 00 – 12 Volt

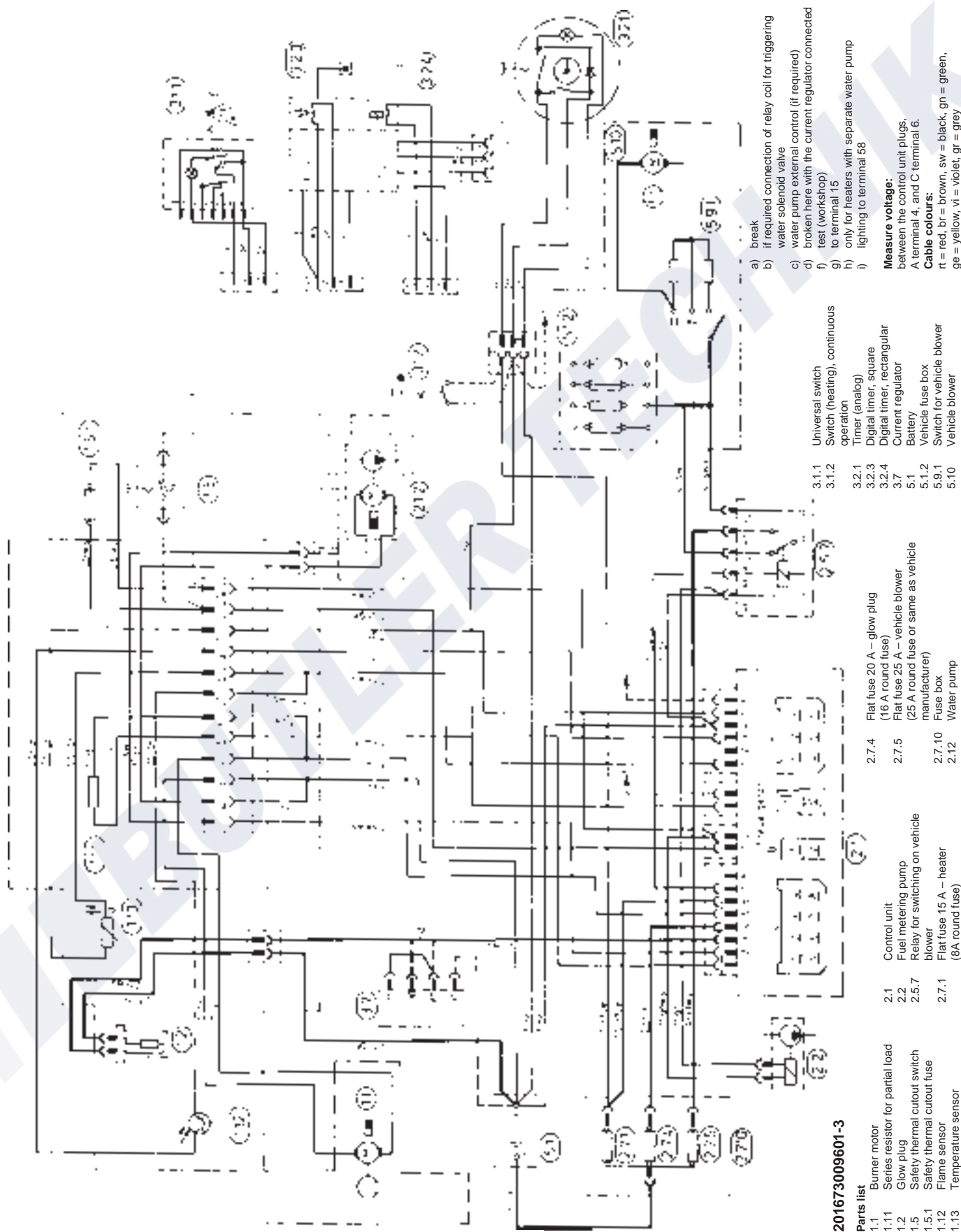

D 7 W 25 1667 05 00 00 – 24 Volt

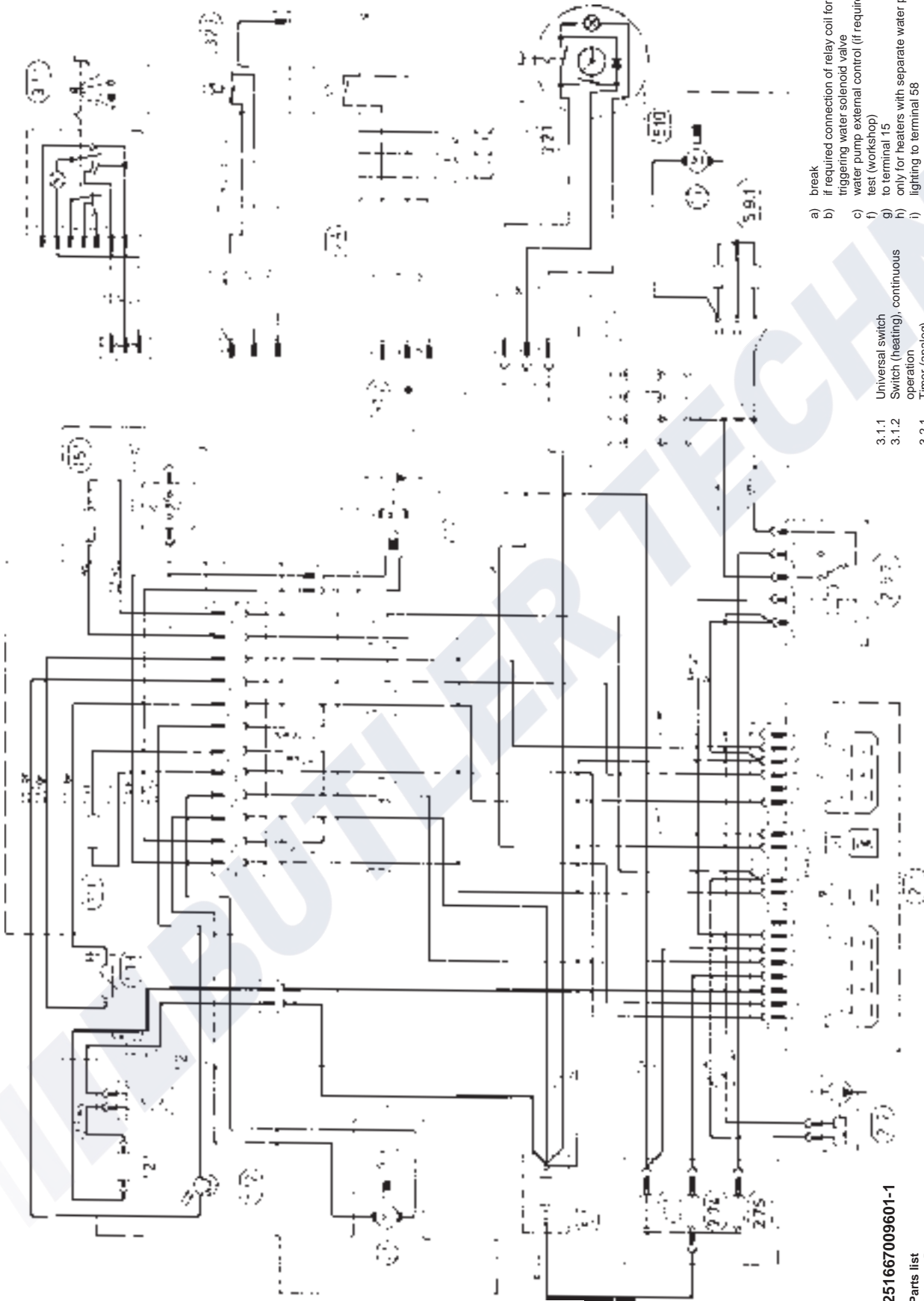

251667009601-1

Parts list

- 1.1 Burner motor
- 1.1.1 Series resistor for partial load
- 1.2 Glow plug
- 1.2.1 Series resistor for glow plug
- 1.5 Safety thermal cutout switch
- 1.5.1 Safety thermal cutout fuse
- 1.12 Flame sensor

- 1.13 Temperature sensor
- 2.1 Control unit
- 2.2 Fuel metering pump
- 2.5.7 Relay for switching on vehicle blower
- 2.7.1 Flat fuse 15 A – heater (8 A round fuse)

- 2.7.4 Flat fuse 20 A – glow plug (16 A round fuse)
- 2.7.5 Flat fuse 25 A – vehicle blower (25 A round fuse or same as vehicle manufacturer)
- 2.12 water pump

- 3.1.1 Universal switch
- 3.1.2 Switch (heating), continuous operation
- 3.2.1 Timer (analog)
- 3.2.3 Digital timer, square
- 3.2.4 Digital timer, rectangular
- 5.1 Battery
- 5.1.2 Vehicle fuse box
- 5.9.1 Vehicle blower switch
- 5.10 Vehicle blower

- a) break
- b) if required connection of relay coil for triggering water solenoid valve
- c) water pump external control (if required)
- f) test (workshop)
- g) to terminal '15'
- h) only for heaters with separate water pump
- i) lighting to terminal 58

Measure voltage:

between the control unit plugs,

A terminal 4, and C terminal 6

Cable colours:
 rt = red, br = brown, sw = black, gn = green,
 ge = yellow, vl = violet, gr = grey



Wiring diagram for unit D 7 W 25 1807 05 00 00 – 12 Volt (Parts list see page 14)

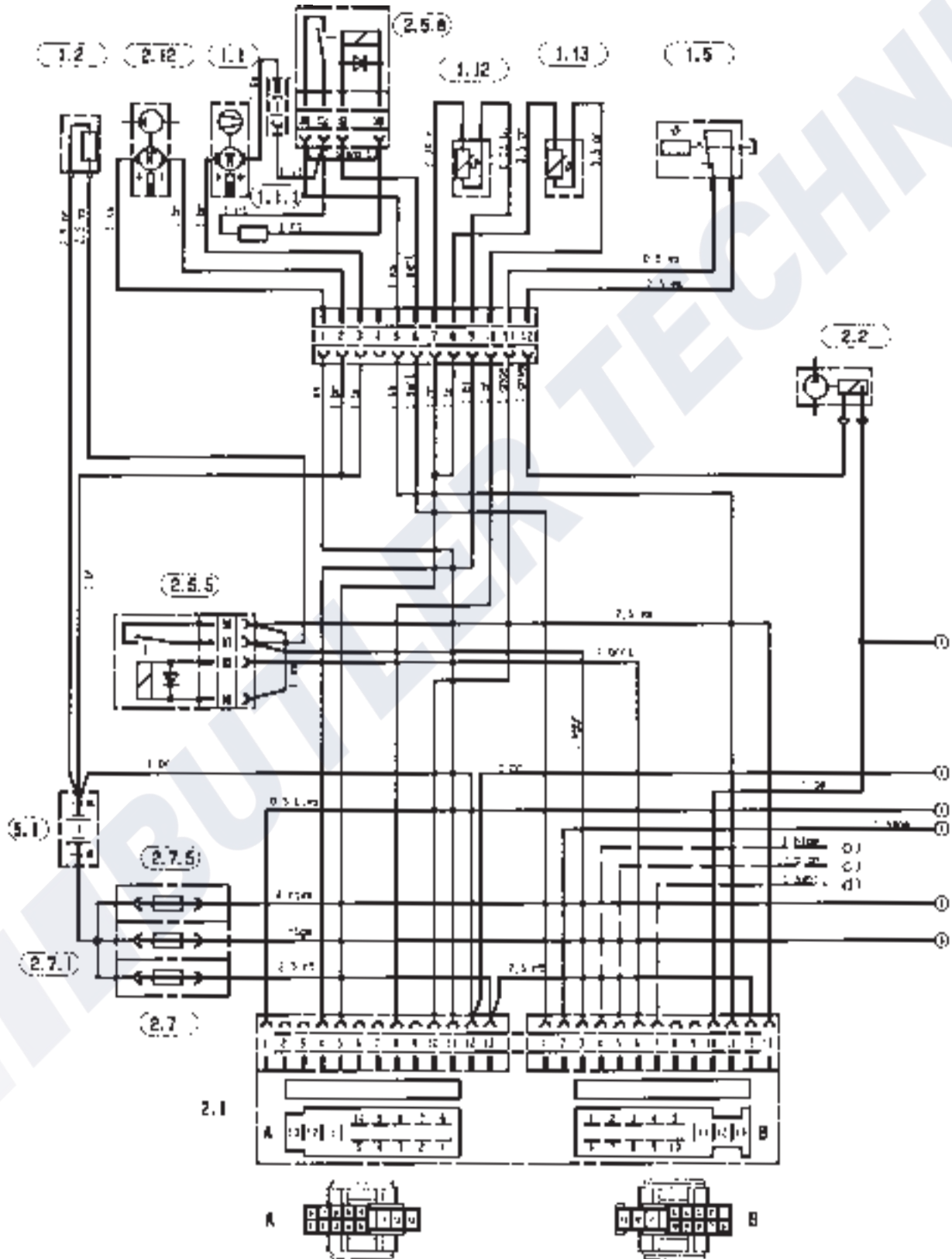

Wiring diagram for unit D 7 W 25 1807 05 00 00 – 12 Volt

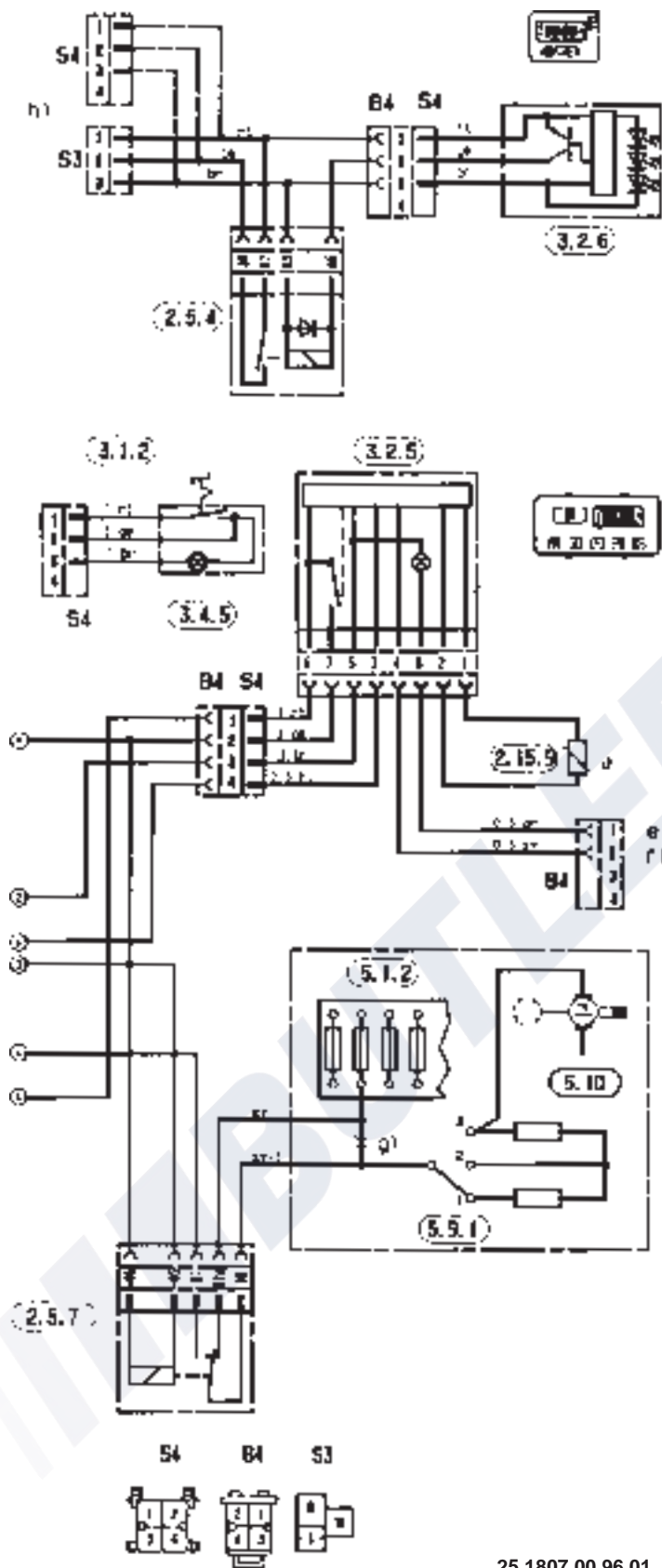

Parts list

- 1.1 Burner motor
- 1.1.1 Resistance for burner motor (partial load)
- 1.2 Glow plug
- 1.5 Overheating switch
- 1.12 Flame controller
- 1.13 Temperature sensor
- 2.1 Control unit
- 2.2 Fuel metering pump
- 2.5.4 Switch-on relay
- 2.5.5 Glow plug timing
- 2.5.7 Relay vehicle fan
- 2.5.8 Relay motor speed switch-over
- 2.7 Main fuse (25 A)
- 2.7.1 Fuse activation (5 A)
- 2.7.5 Fuse vehicle fan (25 A)
- 2.12 Water pump
- 2.15.9 Sensor, outer temperature
- 3.1.2 Heating switch (continuous operation)
- 3.2.5 Timer, 7 days
- 3.2.6 Timer, mini
- 3.4.5 „On“ control lamp
- 5.1 Battery
- 5.1.2 Fuse strip in vehicle
- 5.9.1 Vehicle fan switch
- 5.10 Vehicle fan
- a) Connection for operator device
- b) External triggering for water pump
- c) Temperature lowering
- d) Switch-over solenoid
- e) Illumination terminal 58 to terminal 15
- f) split lead
- g) remove S3 and fit S4

Connector and jack housings are shown from the lead incoming side.



Repair instructions

Available spare parts: see spare parts list

Repair procedures

1. Removing the glow plug
2. Removing the plug filter
3. Removing the series resistor
4. Removing the cover
5. Removing the 12-pin plug

6. Removing the temperature sensor
7. Removing the flame sensor
8. Removing the safety thermal cutout fuse/switch
9. Removing the partial-load resistor

10. Removing the water pump
11. Removing the combustion air blower
12. Removing the burner
13. Removing the heat exchanger
14. Removing the cover and bracket
15. Bleeding the coolant system

1. Removing the glow plug

Remove glow plug cap.
 Unscrew hexagonal nut and take off plug cable.
 Unscrew glow plug.
 Remove any charring on the glow plug coil, or replace glow plug.

Important!

Additional maintenance work when glow plug fails.

Clean flame sensor.
 Clean combustion air intake in glow plug fitting with a brush or with another suitable tool. To do so, unscrew the glow plug and pull out the plug filter.
 If the heater is fitted with a plug adapter, unscrew the adapter.
 Check the plug filter and replace if severely clogged.

For D 7 W only

Measure the glowing time of the glow plug after the flame.

Install and connect up the glow plug.
 Connect a test lamp to the glow plug and keep a stop clock ready.
 Switch on heater and measure glowing time of the glow plug after the flame.
 The glowing time may be 30 – 60 seconds.
 If the glowing time exceeds 60 seconds, measure fuel quantity, check fuel pipes, if necessary replace flame sensor.

2. Removing the plug filter

Unscrew glow plug.
 If the heater is fitted with a plug adapter, unscrew the adapter.
 Remove the plug filter from the glow plug fitting.

Please note:

During installation, please insert the plug filter in the plug fitting as shown in diagram 1 and 2.

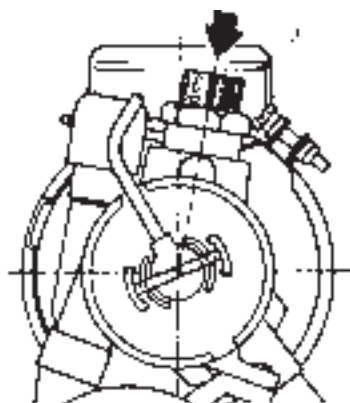

Fig. 1



Fig. 2

Sketch 1



- ① Plug filter
- ② Reduction piece
- ③ Sealing ring

Sketch 2



3. Removing the series resistor

Remove the cap from the series resistor.
Loosen the hex. nut.
Detach the cable.
Unscrew the series resistor.

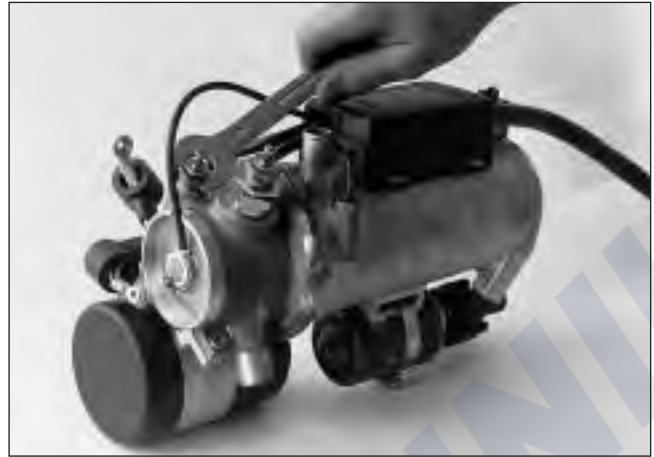

Fig. 3

4. Removing the cover

Unclip the cover from the holder using a screwdriver.

Note when installing:

The cover cap must be fitted splash-water tight, so ensure that all grommets are properly positioned.

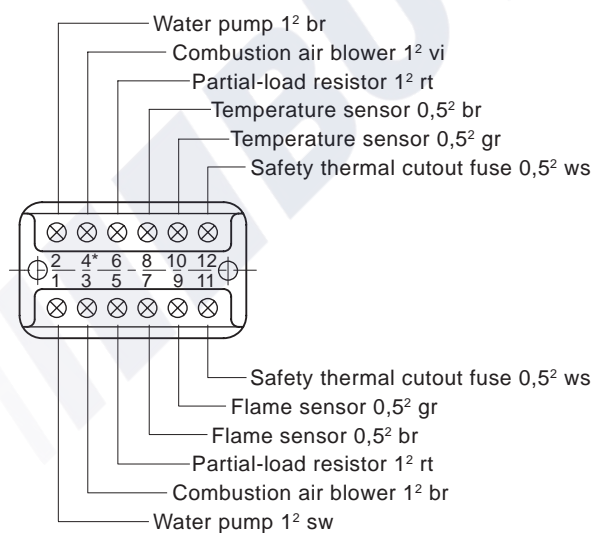

Fig. 4

5. Removing the 12-pin plug

Remove the cover.
Unclip the plug from the holder using a screwdriver.
Dismantle the plug.

Sketch 3



* There is no connector pin 4 in unit 25 1807 05 00 00 – 12 volt.



Fig. 5

Note:

After removing the 12-pin connector, connect cable harness back to connector, then remove connector lid (if cable harness is not connected again, all the connector pins will fall out).



6. Removing the temperature sensor

Before removing the sensor, reduce the excess pressure in the cooling system by opening the radiator filler cap. To prevent the coolant from flowing out pinch the water supply and return hoses shut.

Remove the cover.

Remove the 12-pin plug (note instructions on page 16).

Take the plug pins 8/10 out of the plug housing (see sketch 3 page 16).

Unscrew the temperature sensor.

After installation, bleed the water circuit.

See repair procedure 15.



Fig. 6

7. Remove flame sensor

for units **B 7 W 20 1673 05 00 00 – 12 Volt,**

D 7 W 25 1666 05 00 00 – 12 Volt and 25 1667 05 00 00 – 24 Volt

Remove cover.

Take out 12-pin connector (note instructions on page 16).

Remove connector pins 7/9 from connector housing (see sketch 3 page 16).

Unclip spring retainer.

Remove flame sensor from holder.



Fig. 7

7a. Remove flame sensor

for unit **D 7 W 25 1807 05 00 00 – 12 Volt**

Remove cover.

Take out 12-pin connector (note instructions on page 16).

Remove connector pins 7/9 from connector housing (see sketch 3 page 16).

Unscrew flame sensor from exhaust fitting using wrench size SW 9.



Fig. 7a

**8. Remove overheating switch or overheating fuse for units
B 7 W 20 1673 05 00 00 – 12 Volt,
D 7 W 25 1666 05 00 00 – 12 Volt and 25 1667 05 00 00 – 24 Volt**

First the overpressure in the cooling system must be decreased by opening the lid of the cooler cover.
To prevent the coolant from leaking, pinch off the water inlet and water outlet hoses. Remove the cover.
Remove the 12-pin connector (note instructions page 16).
Take connector pins 11/12 out of the connector housing (see sketch 3 page 16).
Unscrew the overheating switch or overheating fuse.

Note when installing:

The thread of the overheating switch or overheating fuse should be greased with Molykote paste and the O-ring with Vaseline or other suitable lubricants.
Screw in the overheating switch or overheating fuse by hand only until you can feel the resistance indicating that it is in contact with the heat exchanger.

Vent the water circuit after installation (see repair stage 15).



Fig. 8

**8a. Remove overheating switch for unit
D 7 W 25 1807 05 00 00 – 12 Volt**

First the overpressure in the cooling system must be decreased by opening the lid of the cooler cover.
To prevent the coolant from leaking, pinch off the water inlet and water outlet hoses. Remove the cover.
Remove the 12-pin connector (note instructions page 16).
Take connector pins 11/12 out of the connector housing (see sketch 3 page 16).
Unscrew the cross-recessed screws.
Remove the (spring-loaded) overheating switch.

Note when installing:

On removing the overheating screw, the O-ring and seal should be replaced. Grease the O-ring with Vaseline or another suitable lubricant.

Vent the water circuit after installation (see repair stage 15).



Fig. 8a

9. Removing the partial-load resistor

Remove the cover.
Remove the 12-pin plug (note instructions page 16).
Take the plug pins 5/6 out of the plug housing (see sketch 3 page 16).
Remove the retaining clips from the partial-load resistor.
Remove the partial-load resistor.



Fig. 9



10. Removing the water pump

Before removing the pump, reduce the excess pressure in the cooling system by opening the radiator filler cap.

To prevent the coolant from flowing out pinch the water supply and return hoses shut.

Remove the cover.

Remove the 12-pin plug (note instructions page 16).

Take the plug pins 1/2 out of the plug housing (see sketch 3 page 16).

Undo the fastening clip of the water pump.

Remove the water pump.

Note when installing:

A new O-ring must be fitted when the water pump is removed. Grease the O-ring with Vaseline or other suitable lubricants.

After installation, bleed the water circuit.

See repair procedure 15.



Fig. 10

11. Removing the combustion air blower

Remove the cover.

Remove the 12-pin plug (note instructions page 16).

Take the plug pins 3/4 out of the plug housing (see sketch 3 page 16).

Loosen the fastening screw and remove the combustion air blower.

Note when installing:

Grease the O-ring on the combustion air blower connection with Vaseline or other suitable lubricants.

Before fitting the combustion air blower to the heater, turn the fastening screw into the blower housing to cut the tread.



Fig. 11

12. Removing the burner

Before removing the burner, reduce the excess pressure in the cooling system by opening the radiator filler cap.

To prevent the coolant from flowing out pinch the water supply and return hoses shut.

Remove the heater.

Remove the combustion air blower.

Remove the plug cable and – in the case of 24 V heaters – also the cable from the series resistor.

Remove the flame sensor.

Undo the clamping clip and remove the burner.

Note when installing:

Check the O-ring for correct seating.

After installation, bleed the water circuit (see repair procedure 15).

Check for tightness in a trial run.



Fig. 12

13. Removing the heat exchanger

Before removing the heat exchanger, reduce the excess pressure in the cooling system by opening the radiator filler cap. To prevent the coolant from blowing out pinch the water supply and return hoses shut.

Remove the heater.

Remove the burner.

Lift the safety thermal cutout fuse or switch off the heat exchanger by one turn.

Remove the temperature sensor.

Lever the heat exchanger out of the water jacket using screwdrivers. Remove the heater exchanger from the water jacket. (Fig. 13a).

Note when installing:

Fit a new O-ring when the heat exchanger is removed.

Grease the O-ring with Vaseline or other suitable agents.



Fig. 13



Fig.13a

14. Removing the cover and bracket

Remove the cover.

Remove the 12-pin plug.

Detach the 2-pin plug.

Remove the partial-load resistor.

Remove all grommets.

Take the bracket off the jacket.

Note when installing:

The cover cap must be fitted so that it is splash-water tight, so ensure that all grommets are properly positioned.



Fig. 14



15. Bleeding the cooling water system

Se the heater lever fully in the „Warm” setting.
 Top up the cooling water.
 Start the vehicle engine and run it until the radiator thermostat has opened.

**For units B 7 W 20 1673 05 00 00 – 12 Volt,
 D 7 W 25 1666 05 00 00 – 12 Volt and 25 1667 05 00 00 – 24 Volt**
 To vent the cooling water circuit (heater), trigger the water pump at the control unit with +, 6-pin connector, terminal A6 (see sketch 4).

For unit D 7 W 25 1807 05 00 00 – 12 Volt
 To vent the cooling water circuit (heater), trigger the water pump at the control unit with +, 13-pin connector, terminal B4 (see sketch 5).

If necessary top up cooling water.
 Please refer also to the vehicle manufacturer’s instructions on bleeding the water circuit.

Check for tightness in a trial run.

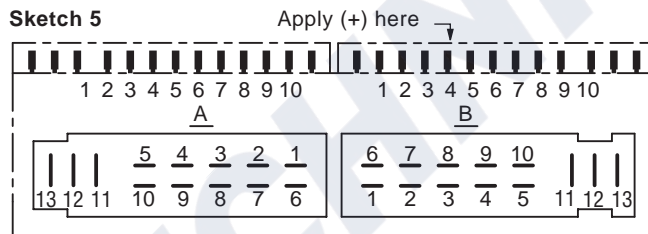
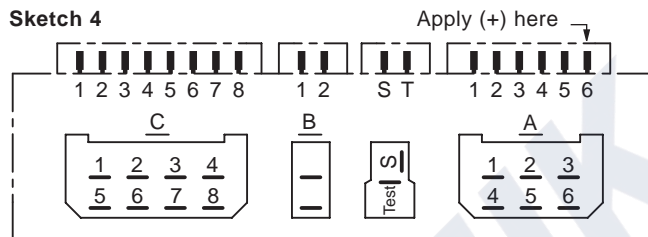

Measuring the fuel quantity

Important: only measure the fuel quantity when the battery is sufficiently charged. At least 11/22 V and at most 13/26 V should be applied at the control unit during measurement.

1. Preparation

Pull out the plug terminal underneath the cap on the heater and connect a test lamp.
 Detach the fuel line from the heater and introduce it into a measuring glass (size 25 cm³).

**For units B 7 W 20 1673 05 00 00 – 12 Volt,
 D 7 W 25 1666 05 00 00 – 12 Volt and 25 1667 05 00 00 – 24 Volt**
 Connect voltmeter to the 8-pin connector terminal C6 (+) and to the 6-pole connector terminal A4 (-) of the control unit.

For unit D 7 W 25 1807 05 00 00 – 12 Volt
 Connect voltmeter to the 13-pin connector terminal A13 (+) and terminal A12 (-) of the control unit.

Switch on the heater. When fuel is being pumped evenly (approx. 25 – 55 seconds after switch-on), the fuel line is filled and bled. Switch off the heater and empty the measuring glass.

2. Measurement

Switch on the heater.
 Fuel starts being pumped some 25 – 55 seconds after switch-on. Hold the measuring glass at the level of the plug during measurement. Read off the voltage at the voltmeter. Fuel feed is cut off automatically after 90 sec. Switch off the heater. Read off the fuel quantity in the measuring glass.

3. Evaluation

Transpose the readings into the appropriate diagram on page 22.
 The fuel consumption is OK if the intersection of the two readings is within the limit curves.
 If the intersection is outside the limit curves, a new fuel metering pump is required.

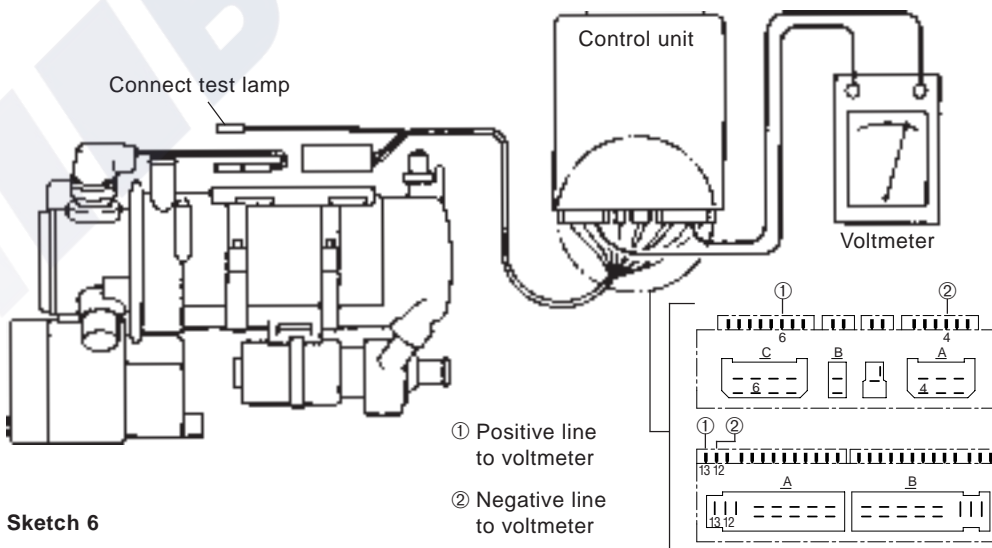

Connection of voltmeter to control unit

**Unit:
 B 7 W 20 1673 05 00 00 – 12 Volt
 D 7 W 25 1666 05 00 00 – 12 Volt
 D 7 W 25 1667 05 00 00 – 24 Volt**

**Unit:
 D 7 W 25 1807 05 00 00 – 12 Volt**

Fuel diagrams

