

DW 80 (Diesel)

List of Contents

1 Introduction

- 1.1 Scope and Purpose 101
- 1.2 Meaning of Warnings, Cautions, and Notes 101
- 1.3 Additional Documentation to be used 101
- 1.4 Safety Information and Regulations..... 101
 - 1.4.1 General Safety Notes 101
- 1.5 Legal Provisions for Installation 102
- 1.6 Corrections and Improvements..... 103

2 General Description

- 2.1 Combustion Air Fan 202
- 2.2 Heat Exchanger 202
- 2.3 Temperature Sensor 203
- 2.4 Temperature Limiter 203
- 2.5 Burner Insert 203
- 2.6 Glow Plug 203
- 2.7 Flame Sensor 203
- 2.8 Combustion Tube 203
- 2.9 Circulation Pump 203
- 2.10 Control Unit..... 203
- 2.11 Dosing Pump 203

3 Troubleshooting

- 3.1 Switch-on 301
- 3.2 Heating Operation..... 301
- 3.3 Control Operation 301
- 3.4 Switch-off 301
- 3.5 Functions of the Heater in TRS Vehicles..... 301
- 3.6 Malfunctions..... 303
 - 3.6.1 Switch-off upon Failure..... 303
 - 3.6.2 Diagnosis after Switch-off upon Failure (Thermo 90)..... 303
 - 3.6.3 Diagnosis after Switch-off upon Failure (Thermo 90 S)..... 303

4 Technical Data..... 401

5 Troubleshooting

- 5.1 General 501
- 5.2 General Failure Symptoms 501
- 5.3 Failure Symptoms after Switch-off upon Failure..... 502
- 5.4 Visual Inspection for Assessment of Burner Condition..... 503
 - 5.4.1 Burner Housing..... 503
 - 5.4.2 Rear Wall with Metal Evaporator 504
 - 5.4.3 Combustion Chamber..... 504
 - 5.4.4 Burner Assembly 504

6 Functional Tests

6.1 General 601

6.2 Adjustments 601

 6.2.1 Adjustment of the CO₂ Contents 601

6.3 Components Testing 601

 6.3.1 Temperature Sensor Resistance Check 601

 6.3.2 Glow Plug Resistance Test 601

 6.3.3 Flame Sensor Resistance Test 601

 6.3.4 Combustion Air Fan Test 601

7 Circuit Diagrams

7.1 General 701

8 Servicing

8.1 General 801

8.2 Work on the Heater 801

8.3 Work on the Vehicle 801

8.4 Heater Test Run 801

8.5 Servicing 801

8.6 Visual Inspections and Installation Regulations 803

 8.6.1 Connection to the Vehicle's Cooling System 803

 8.6.2 Connection to the Vehicle's Fuel System 803

 8.6.3 Dosing Pump 805

 8.6.4 Fuel Filter 806

 8.6.5 Combustion Air Supply 806

 8.6.6 Exhaust Line 806

8.7 Removal and Installation 807

 8.7.1 Heater, Removal and Installation 807

 8.7.2 Replacement of Circulation Pump 807

 8.7.3 Replacement of Temperature Limiter 807

 8.7.4 Replacement of Temperature Sensor 807

 8.7.5 Replacement of Combustion Air Fan 807

8.8 First Operation 807

9	Repair	
9.1	General	901
9.1.1	Work on Components after Disassembly	901
9.2	Disassembly and Assembly	902
9.2.1	Electrical Connections	902
9.2.2	Replacement of Circulation Pump	903
9.2.3	Replacement of Temperature Limiter	904
9.2.4	Replacement of Temperature Sensor	904
9.2.5	Replacement of Combustion Air Fan.....	906
9.2.6	Replacement of Burner, Flame Sensor, and Glow Plug.....	907
9.2.7	Replacement of Burner Head	909
9.2.8	Replacement of Heat Exchanger.....	910
10	Packaging/Storage and Shipping	
10.1	General	1001

List of Figures

301	Functional Sequence	302
501	General Failure Symptoms	501
502	Failure Symptoms after Switch-off upon Failure	502
503	Visual Inspection, Burner Real Wall.....	503
504	Visual Inspection, Pilot Flame Exit Bore	504
505	Visual Inspection, Burner Assembly	504
701	Pin Assignment.....	701
702	Circuit Diagram Automatic Control for Thermo 90, 12 and 24 V with Triple Timer	702
703	Circuit Diagram Automatic Control Thermo 90-TRS, 24 V	703
704	Circuit Diagram Automatic Control for Thermo 90 S, 12 and 24 V with Standard Timer	704
705	Circuit Diagram Automatic Control for Thermo 90 S-TRS, 24 V	705
706	Circuit Diagram Automatic Control for Thermo 90 S-TRS, 24 V without Auxiliary Drive	706
801	Example for Heater Installation in Lorry.....	802
802	Fuel Supply	803
803	Webasto Fuel Tank Tap.....	804
804	Fuel Tapping from Plastic Tank (tapping via fuel drain plug).....	804
805	Fuel Tapping from Plastic Tank (tapping via fitting plate)	804
806	Pipe/Hose Connection	805
807	Dosing Pump, Installation Location and Attachment	805
808	Exhaust Muffler, Direction of Flow	806
901	Electrical Connections	902
902	Replacement of Circulation Pump	903
903	Replacement of Temperature Limiter and Temperature Sensor	905
904	Replacement of Combustion Air Fan.....	906
905	Replacement of Burner, Flame Sensor, and Glow Plug	908
906	Replacement of Burner Head	909

1 Introduction

1.1 Scope and Purpose

This repair shop manual is intended to support familiarised personnel in the repair of Thermo 90 and Thermo 90 S for the Diesel and fuel type.

The water heater may only be operated with the specified fuel (diesel or also fuel oil EL) and the relevant designated type of electrical connection.

1.2 Meaning of Warnings, Cautions, and Notes

WARNINGS, CAUTIONS, and NOTES in this manual have the following meaning:

WARNING

This heading is used to highlight that non-compliance with instructions or procedures may cause injuries or lethal accidents to personnel.

CAUTION

This heading is used to highlight that non-compliance with instructions or procedures may cause damage to equipment.

NOTE

This heading is used to highlight and draw specific attention to information.

1.3 Additional Documentation to be used

This workshop manual contains all information and procedures necessary for the repair of heaters Thermo 90 and Thermo 90 S.

The use of additional documentation is normally not necessary.

Operating instructions/installation instructions and the vehicle specific installation proposal may be used as complementary information as necessary.

1.4 Safety Information and Regulations

The general safety regulations for the prevention of accidents and the relevant operating safety instructions have to be observed at all times. "General Safety Regulations" beyond the scope of these regulations are detailed in the following.

The specific safety regulations applicable to this manual are highlighted in the individual chapters by Warnings, Cautions, and Notes.

1.4.1 General Safety Notes

Within the scope of the StVZO (Road Licensing Regulations of the Federal Republic of Germany) "Design General Approvals", laid down by the Federal-Office for Motor Traffic, exist for the Water Heater Thermo 90 with the following official marks of conformity:

- ~S231 for water heater Thermo 90 and Thermo 90 S Fuel Type BW 80
- ~S232 for water heater Thermo 90 and Thermo 90 S Diesel Type DW 80 and for water heater Thermo 90-TRS and Thermo 90 S-TRS Diesel Type DW 80.

The installation of the heaters is to be performed in accordance with the installation instructions and must be checked in case of

- a) the vehicle type inspection in accordance with § 20 StVZO
- b) the individual inspection in accordance with § 21 StVZO or
- c) the examination in accordance with § 19 StVZO performed by an officially authorised expert or examiner for road traffic, a vehicle inspector or a public servant as per section 7.4a of Annex VIII to the StVZO.

In the event of c) the installation must be certified on the acceptance certificate included in the copy of the "General Operating License" giving details about

- manufacturer
- type of vehicle and
- vehicle identification number.

This validates the "Design General Approval". **The acceptance certificate must be kept with the vehicle.**

The year of first operation must be permanently marked on the identification label by removing the relevant number of the year.

The heaters are cleared for heating the passenger and driver cabins but not for heating compartments used for the transportation of dangerous goods.

The use of the heater in special vehicles (e.g. vehicles for the transportation of dangerous goods TRS) or vehicles not subject to the StVZO (e.g. ships) is partly governed by regional regulations.

1 Introduction

For the installation of the Thermo 90-TRS or Thermo 90 S-TRS in vehicles used for the transportation of dangerous goods, in addition to the StVZO, the requirements in TRS 002 and TRS 003 (Technical Guidelines for the Transportation of Dangerous Goods on Roads) must be met.

The heater may only be installed in motor vehicles or in independent heating systems with a minimum coolant capacity of 6 litres.

The heater must not be installed in the passenger or driver compartments of vehicles. Should the heater nevertheless be installed in such a compartment, the installation box must be sealed tight against the vehicle interior. There must be sufficient ventilation of the installation box from the exterior in order not to exceed a maximum temperature of 60° C in the installation box. Excessive temperatures may cause malfunctions.

WARNING

Due to the danger of poisoning and suffocation, the heater must not be operated in enclosed areas such as garages or workshops without an exhaust venting facility, not even if the start-up is activated by the timer or telestart device.

At filling stations and fuel depots the heater must be switched off as there is a potential danger of explosion.

CAUTION

Where flammable fumes or dust may build up (e.g. in the vicinity of fuel, coal, wood, cereal depots, or similar installations) the heater must be switched off to prevent explosions.

In the vicinity of the water heater a temperature of 85° C must not be exceeded under any circumstances (e.g. during body paint work). A violation of this temperature limit may cause permanent damage to the electronics.

When checking the cooling water level, proceed in accordance with the vehicle manufacturer's instructions. The water in the heating circuit of the heater must contain a minimum of 10% of a quality brand anti-freeze.

Ignoring the installation instructions and its procedures will void the warranty granted by Webasto. The same applies for repairs performed by unskilled personnel and repairs without using original spare parts. This will void the water heater's "Official Marks of Conformity" and thus the vehicle's permit of operation.

1.5 Legal Provisions for Installation

For testing the heater in accordance with § 19, 20, or 21 of the StVZO the following regulations are to be observed in particular (§ 22 a StVZO):

Testing is performed upon presentation of the operating and installation instructions of the manufacturer. The year of the initial operation must be durably marked on the heater identification plate by the installing person.

Extracting combustion air from the vehicle interior is not permissible.

The exhaust line outlet is to be positioned at the top, at the side, or in case of exhaust venting, below the vehicle floor, to the nearest possible location of the vehicle's or cockpit side or rear end. Exhaust pipes must be routed so that exhaust fumes are unlikely to penetrate into the vehicle's interior. The function of any parts vital for vehicle operation must not be impaired. Condensation accumulation in the exhaust line must be directly drained. A condensation drain hole may be provided as required.

In installations the openings of the combustion air inlet and the exhaust outlet must not allow a ball of 16 mm in diameter to be inserted.

Electrical lines, switch gear, and control gear of the heater must be located in the vehicle so that their proper function cannot be impaired under normal operating conditions.

For the routing of fuel lines and the installation of additional fuel tanks, §§ 45 and 46 of the StVZO are to be adhered to. The most important regulations are:

- Fuel lines are to be designed in such a way that they remain unaffected by torsional stresses in the vehicle, engine movement, and the like. They must be protected against mechanical damage. Fuel-carrying parts are to be protected against excessive heat and are to be arranged so that any dripping or evaporating fuel can neither accumulate nor be ignited by hot components or electrical equipment.
- In busses, fuel lines and fuel tanks must not be located in the passenger area or in the driver's compartment. In these type of vehicles the fuel tanks must be located such that they do not pose a direct hazard to the exits in the event of a fire. Fuel supply must not be by means of gravity or pressurisation of the fuel tank.

- Installation Instructions for Webasto fuel tanks for the fuel supply of water heaters in vehicles:
In busses the installation is not permitted in the passengers or driver's compartment.
- The fuel filler neck must not be located in the passengers or driver's compartment of any vehicle.
- Fuel containers for carburettor fuel must not be located immediately behind the front panelling of the vehicle. They must be separate from the engine so that even in case of an accident the inflammation of fuel is unlikely to be expected. This does not apply for towing vehicles with an open cockpit.

All fuel containers offered in the Webasto Accessories Catalogue are suitable for a maximum operating pressure of 0.15 bar overpressure.

All fuel containers offered in the Webasto Accessories Catalogue are subjected during manufacture to individual pressure testing with at least 0.3 bar overpressure.

- The fuel containers must either be equipped with a vent cap or be ventilated in another way (ventilation line).

Only filler caps in accordance with DIN 73400 may be used.
- The operational state of the heater, i.e. an indication "on" or "off", must be easily and clearly visible.

1.6 Corrections and Improvements

Deficiencies, improvements, or proposals for correction of this workshop manual are to be mailed to:

Webasto Thermosysteme International GmbH
Abt. Technische Dokumentation
D-82131 Stockdorf
Telefon: 0 89 / 8 57 94 - 5 42
Telefax: 0 89 / 8 57 94 - 7 57

1 Introduction

2 General Description

The water heater Webasto Thermo 90 and Thermo 90 S in combination with the vehicle's own heating system is used to:

- heat the cabin
- defrost the windshields
- preheat water-cooled engines.

The water heater operates independent from the vehicle engine and is connected to the cooling system, the fuel system, and the electrical system of the vehicle.

The heater, designed to the evaporator principle, operates intermittently and is controlled by the temperature sensor.

Dependent on the deviation of the current coolant temperature from the rated value of the temperature sensor, combustion performance is continuously controlled within the range from 1.8 to 7.6 kW for Diesel operated heaters and within 2.0 to 7.6 kW for fuel operated water heaters. For an extremely high heating performance requirement (preheating) the maximum performance of 9.1 kW is available in case of Diesel operated water heaters for up to 2 hours after equipment activation.

NOTE

One of the newer models shown. Older models have the cable of the temperature sensor located on the side.

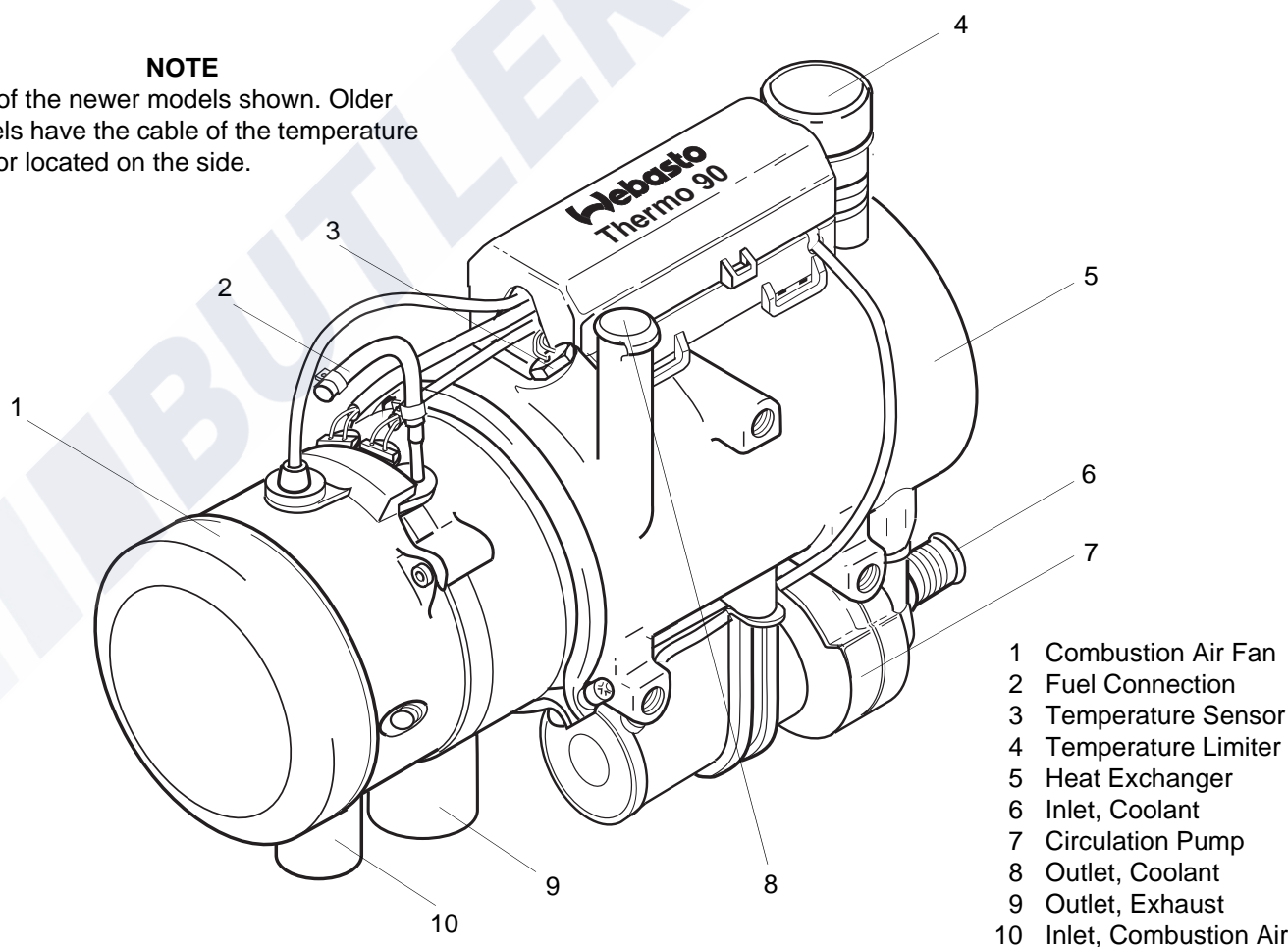

Heater Thermo 90

The water heater Thermo 90 and Thermo 90 S basically consists of:

- combustion air fan
- heat exchange
- burner insert with combustion tube
- circulation pump

For control and monitoring a

- control unit (external)
- flame sensor
- glow plug
- temperature sensor
- temperature limiter

are located inside the unit.

On the Thermo 90 S heater the control unit may also be flanged to the combustion air fan.

Fuel supply is provided externally by a fuel dosing pump.

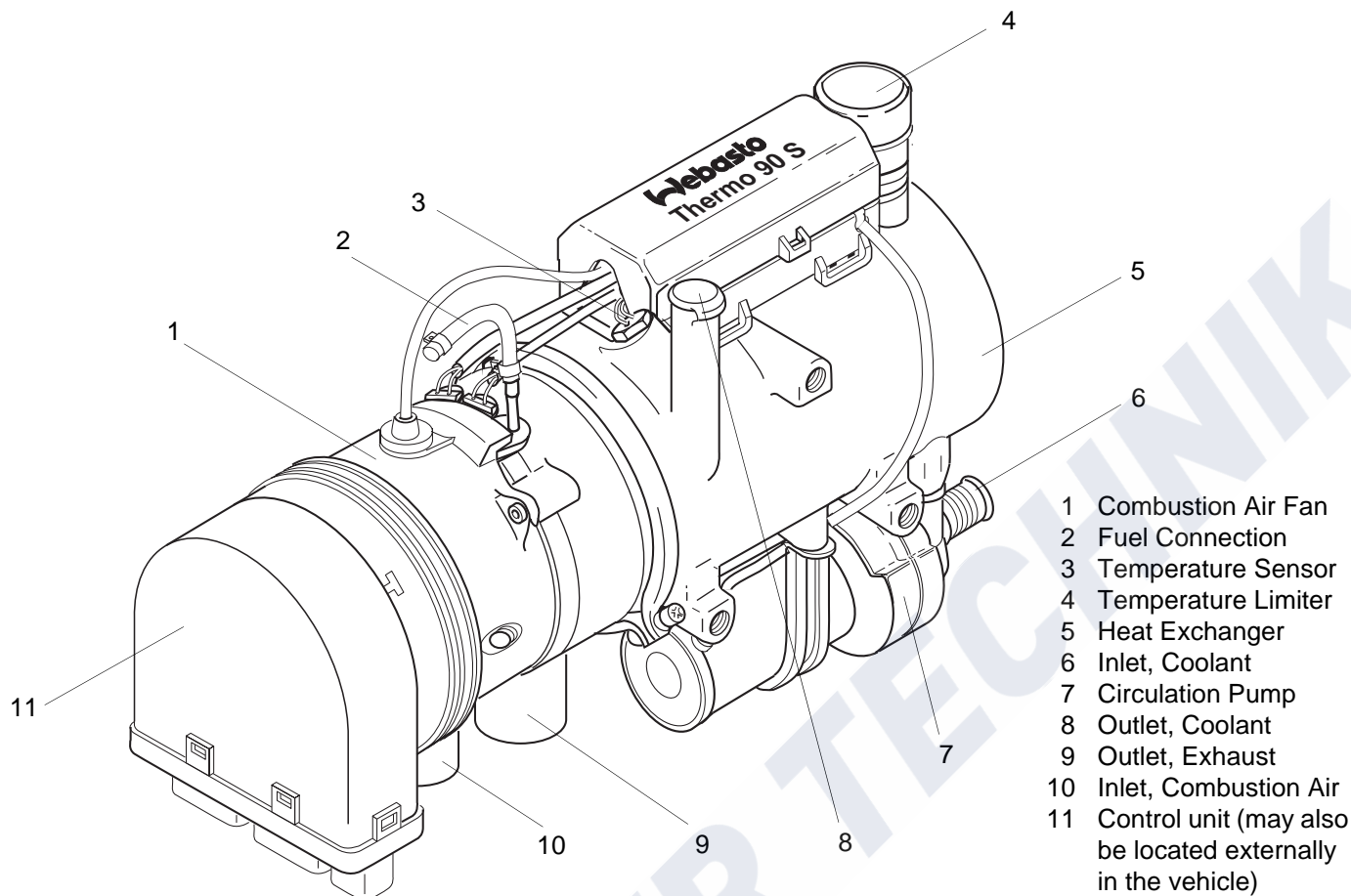

Heater Thermo 90 S

2.1 Combustion Air Fan

The combustion air fan delivers the air required for combustion from the combustion air inlet to the burner insert.

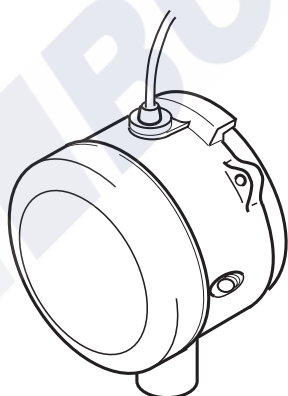

2.2 Heat Exchanger

The heat exchanger dissipates the heat provided by combustion to the coolant circuit.

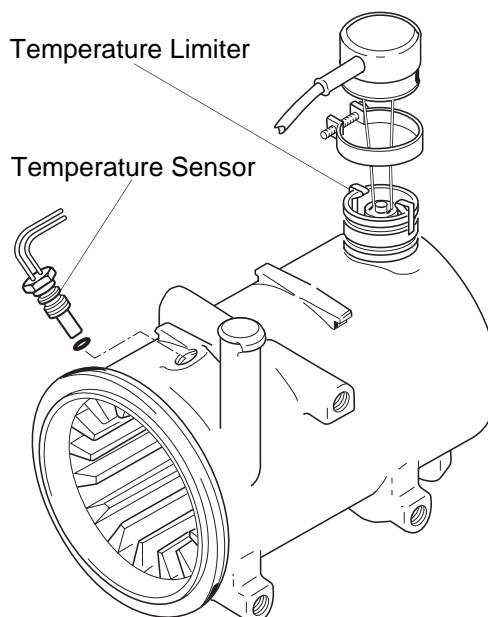

Heat Exchanger

2.3 Temperature Sensor

The temperature sensor senses the coolant temperature in the heat exchanger of the heater unit as electrical resistance. This signal is fed to the control unit for processing.

2.4 Temperature Limiter

The overheat protection (bimetal) protects the heater unit from excessive operating temperatures. The overheat protection responds at a coolant temperature higher than 105° C to switch off the heater.

2.5 Burner Insert

Within the burner insert fuel is distributed in the combustion tube across the burner cross-section.

2.6 Glow Plug

The glow plug ignites the fuel/air mixture at the start of heater operation. The glow plug is acting as an electrical resistor and is located in the burner insert opposite to the flame source.

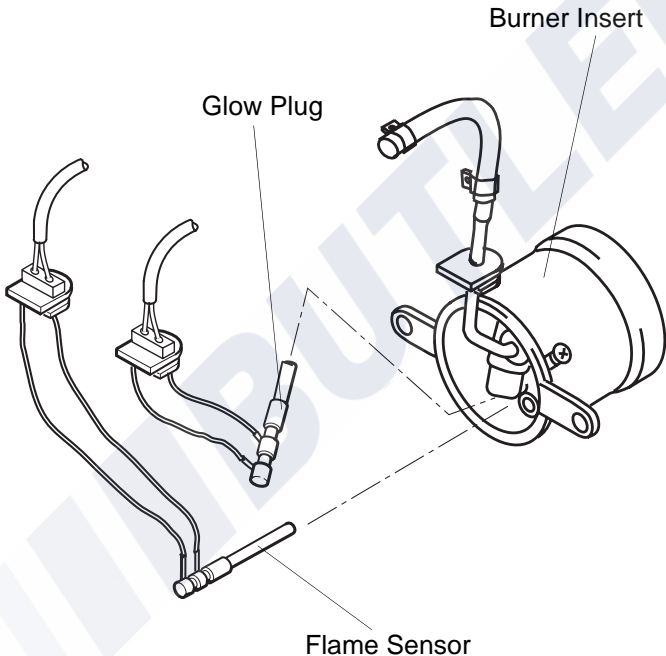

2.7 Flame Sensor

The flame sensor is a low-Ohm PTC resistor, changing its resistance dependent on its heating by the flame. The signals are routed to the control unit for processing. The flame sensor monitors the flame operating condition over the complete duration of heater operation.

2.8 Combustion Tube

Inside the combustion tube the combustion of the fuel/air mixture takes place, heating up the heat exchanger.

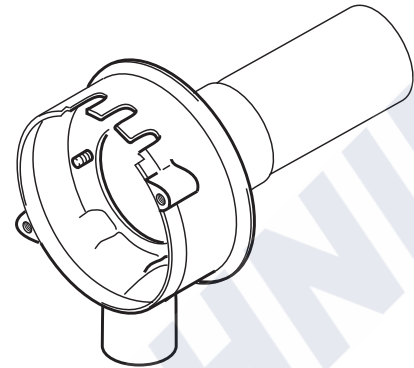

2.9 Circulation Pump

The circulation pump provides for circulation of the coolant in the vehicle and heater circuits. The control unit switches the pump on for operation throughout the entire time of heater operation (also in control idle).

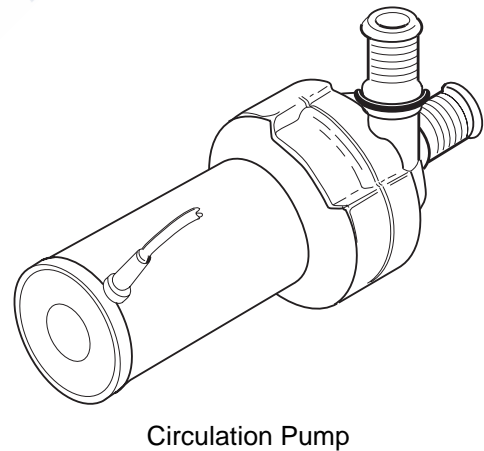

2.10 Control Unit

The control unit is the central controlling device for functional sequencing and monitoring of the combustion operation. It is located externally in the vehicle, but may also be flanged to the combustion air fan on Thermo 90 S heaters.

2.11 Dosing Pump

Fuel supply to the heater and its dosing is ensured externally by a dosing pump. When the heater is deactivated, it also serves as a shut-off facility. The magnetic coil of the dosing pump receives the pulses from the microprocessor of the control unit.

3 Functional Description (Fig. 301)

3.1 Switch-on

When operating the push button "Immediate Heating", the "Operating Indicator" on the timer illuminates

or

by activation with the switch, the operating indicator integrated in the switch illuminates.

Circulation pump, glow plug, and combustion air fan are put into operation.

3.2 Heating Operation

After approx. 50 seconds, combustion commences with the automatically controlled heating operation in full load for a maximum of 2 hours.

The vehicle's own heating blower starts to operate only after the heat carrier (coolant) has accumulated enough heat. After reaching the pre-coded rated temperature (see table Control Temperatures) heating performance precision control will take over in stages down to the lowest part load operation.

3.3 Control Operation

If the coolant temperature rises up to the control idle threshold, the heater enters the control idle phase. The circulation pump, the vehicle's own blower, and the operating indicator remain in operation during the control idle period.

After the coolant has cooled down to the precoded reactivation temperature, the heater resumes operation.

Diesel Operated Water heaters

If the water heater's water temperature is above the rated temperature but has not yet reached the threshold for control idle with the temperature dropping within 10 minutes back to rated temperature (after reaching it for the first time), the water heater reverts to the 9.1 kW heating stage. Should the rated temperature be obtained after 10 minutes, there will be an automatic reactivation only up to heating stage 7.6 kW.

Fuel Operated Water Heaters

The maximum heating performance of fuel operated water heaters is always 7.6 kW.

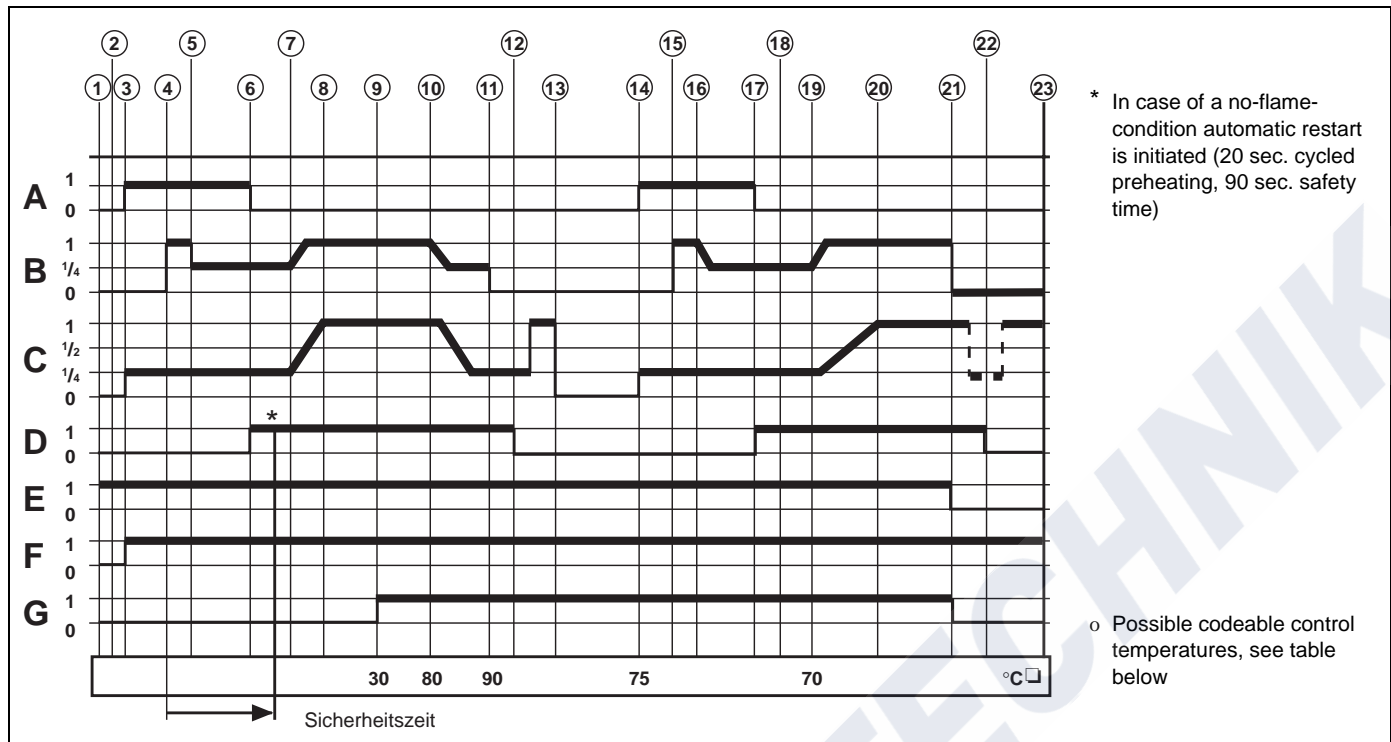

3.4 Switch-off

Vehicles

When switching the heater off, the operation indicator on the timer/switch extinguishes. Combustion ends and run-down is initiated. Circulation pump and combustion air fan, however, continue operation to cool down the heater (run-down) and are automatically deactivated after about 90 seconds. A reactivation of the heater during run-down is permitted.

Room temperature control by means of the vehicle's own heating blower may be provided in addition to employing a room thermostat.

3.5 Functions of the Heater in TRS

The heater is started using the switch. A TRS condition (forced deactivation) will be released after

- the vehicle engine is turned off
- a conveyor facility is started

with the short run-down terminating after 20 seconds.

Then the control unit is in the "error lockout" mode. Prior to reactivation the On/Off switch must be set to "Off".

The isolation switch (emergency off switch) must only be operated in case of emergency, as the heater is switched off without run-down (overheating possible).

Fig. 301 Functional Sequence

Functional Sequence for Thermo 90

- ① Switch-on
- ② Configuration Check
- ③ Preheating 40 sec. (cycled)
- ④ Dosing Pump Priming 5 - 7 sec. (1)
- ⑤ Dosing Pump / Part Load (1/4)
- ⑥ Flame Sensor Take-over
- ⑦ Stabilisation Time
- ⑧ Full Load
- ⑨ Vehicle Blower »On«
- ⑩ Control Range
- ⑪ Control Idle
- ⑫ Flame Sensor »cold« (0)
- ⑬ Run-down completed
- ⑭ Preheating 15 - 20 sec. (cycled)

- ⑮ Dosing Pump Priming 5 - 7 sec. (1)
- ⑯ Dosing Pump / Part Load (1/4)
- ⑰ Flame Sensor Take-over
- ⑱ Stabilisation Time
- ⑲ Coolant Temperature down
- ⑳ Full Load
- ㉑ Switch-off (run-down)
- ㉒ Flame Sensor "cold" (0)
- ㉓ Run-down completed

- A** Glow Plug
B Dosing Pump
C Combustion Air Fan
D Flame Sensor
E Operation Indicator Light
F Circulation Pump

G Vehicle Blower**Setting of Control Temperatures Thermo 90**

Table	Rated Temp. at Sensor	Control Idle	Reactivation after Control Idle
Minus to B6	80° C	90° C	75° C
B6 not used	72° C	82° C	67° C
Plus to B6	65° C	75° C	60° C

On the standard wiring harness B6 is not in use.

NOTE

The selected control idle temperature of the heater should be below the opening temperature of the cooler thermostat!

Setting of Control Temperatures Thermo 90 S

Connection of signal "motor on"/ "motor off" (terminal D+) to the control unit (connector X12, contact 7) will enable different threshold values.

Table	Rated Temp. at Sensor	Control Idle	Reactivation after Control Idle
"Motor on"	72° C	82° C	67° C
"Motor off"	80° C	90° C	75° C

If the signal terminal D+ is not connected, temperatures will be those listed for "motor off".

NOTE

The selected control idle temperature of the heater should be below the opening temperature of the cooler thermostat!

3.6 Malfunctions**3.6.1 Switch-off upon Failure**

In case of a no-flame condition fuel is delivered for a max. of 180 seconds.

In the event of a flame-out during operation fuel is delivered for a max. of 90 seconds.

Should an overheat condition exist (after response of the temperature limiter), no fuel will be delivered.

After switch-off by low voltage protection

	Thermo 90	Thermo 90 S
12 Volt	10.5 V ± 0.5 V	10.5 V – 0.5 V
24 Volt	21 V ± 1 V	21 V – 1 V

for more than 20 seconds there will be no fuel supply.

After removal of the fault there will be an error lock-out. Reset by switch-off and reactivation of the heater.

In case of overheating, the knob of the temperature limiter has to be reset after the unit has cooled down.

CAUTION

To avoid damage to the component, do not attempt to reset the temperature limiter by force while hot.

3.6.2 Diagnosis after Switch-off upon Failure (Thermo 90)

When operated with switch or triple timer the type of error lock-out condition is indicated by an operation indicator light flash code while the heater is in run-down.

After five short signals the following long flash pulses are counted:

- 1x No start (after 2 start attempts)
- 2x Flame-out during operation (repeated > 5)
- 3x Voltage too low
- 4x Premature flame detection
- 5x Flame sensor open or short circuit
- 6x Temperature sensor open or short circuit
- 7x Dosing pump open or short circuit
- 8x Fan motor open or short circuit or wrong speed of fan motor
- 9x Glow plug open or short circuit

3 Functional Description

DW80

3.6.3 Diagnosis after Switch-off upon Failure (Thermo 90 S)

When equipped with a standard timer an error will cause an output to the timer display:

- F 01 No start (after 2 start attempts)
- F 02 Flame-out during operation (repeated > 5)
- F 03 Voltage too low or too high
- F 04 Premature flame detection
- F 05 Flame sensor open or short circuit
- F 06 Temperature sensor open or short circuit
- F 07 Dosing pump open or short circuit
- F 08 Fan motor open or short circuit or wrong speed of fan motor
- F 09 Glow plug open or short circuit
- F 10 Overheating
- F 11 Circulation pump open or short circuit

When operated with switch the type of error lock-out condition is indicated by an operation indicator light flash code while the heater is in run-down.

After five short signals the following long flash pulses are counted:

- 1x No start (after 2 start attempts)
- 2x Flame-out during operation (repeated > 5)
- 3x Voltage too low or too high
- 4x Premature flame detection
- 5x Flame sensor open or short circuit
- 6x Temperature sensor open or short circuit
- 7x Dosing pump open or short circuit
- 8x Fan motor open or short circuit or wrong speed of fan motor
- 9x Glow plug open or short circuit
- 10x Overheating
- 11x Circulation pump open or short circuit

BUTLER TECHNIK

4 Technical Data

As long as no threshold values are given, the following technical data are understood to include tolerances of $\pm 10\%$ usual for heaters at an ambient temperature of $+20^\circ\text{C}$ and at nominal voltage and conditions.

Electrical Components:

Control unit, combustion air fan motor and dosing pump, glow plug, control switch and timer are either of the 12 V or 24 V type.

The components temperature limiter, temperature sensor, and flame sensor are identical in the 12 V and 24 V units.

* not for Thermo 90-TRS

Water Heater	Operation	Thermo 90 Fuel	Thermo 90 Diesel Thermo 90-TRS
Type		BW 80	DW 80
Mark of conformity		~ S231	~ S232
Heater type		Water heater with Ferro-Tec-Technology	
Heat flow	max. control range	2.0 – 7.6 kW	9.1 kW 1.8 – 7.6 kW
Type of fuel		Benzin	Diesel
Fuel consumption	max. control range	0.25 – 1.0 l/h	1.1 l/h 0.19 – 0.9 l/h
Nominal voltage		12 Volt	12 or 24 Volt ¹⁾
Operating voltage range		10 ... 15 Volt	10 ... 15 or 20 ... 30 Volt
Rated power consumption with circulation pump (without vehicle blower)	max. control range	37 W – 83 W	90 W 37 W – 83 W
Permitted ambient temperature:			
Heater	– operation – storage		–40 ... +110° C –40 ... +130° C
Control unit	– operation – storage		–40 ... + 75° C –40 ... + 85° C
Dosing pump	– operation – storage	–40 ... +20° C	–40 ... +40° C –40 ... + 85° C
Permitted overpressure (heat exchanger)	max.		2.0 bar
Heat exchanger capacity			0.15 l
Max. combustion air intake temperature			+40° C
Coolant circuit minimum capacity			6.00 l
Volume flow of circulation pump against 0.15 bar			1650 l/h
CO ₂ in exhaust (perm. operating range)	max.		10 ... 12.0 Vol.-%
CO ₂ -setting values at approx. +20° C and geograph. height above SL	max.	0 m 10 %	500 m 10.6 % 1000 m 11.3 %
Dimensions heater (Tolerance ± 3 mm)		Length Width Height	310 mm (355 mm) ²⁾ 133 mm 220 mm
Weight			4.8 kg

¹⁾ Thermo 90-TRS 24 Volts only

²⁾ Thermo 90-S with control unit mounted on heater

BUTLER TECHNIK

5 Troubleshooting

5.1 General

This section describes troubleshooting procedures for the Water Heater Thermo 90 and Thermo 90 S.

CAUTION

Troubleshooting requires profound knowledge about structure and theory of operation of heater components and may only be performed by skilled personnel.

In cases of doubt refer to Sections 2 or 3 for functional interrelations.

CAUTION

Troubleshooting is normally limited to the isolation of defective components. The following defects are not included in the trouble shooting procedures. Before troubleshooting, check for and eliminate these defects:

- **corrosion on connector**
- **loose contact on connector**
- **wrong crimping on connector**
- **corrosion on electrical wiring and fuses**
- **corrosion on battery terminals**

After any correction of a failure a functional test has to be performed in the vehicle; before switch the heater off and on again.

5.2 General Failure Symptoms

The following table (Fig. 501) lists possible, general failure symptoms.

Failure Symptom	Failure Symptom	Remedy
Heater switches off automatically	No combustion after start or repeat start	Control unit goes to error lock-out. Switch heater off and on again
	Flame extinguishes during operation	If a no-heating condition persists contact Webasto service agent
	Heater overheats due to lack/loss of coolant	Replenish coolant. After cool-down of unit, push button of temperature limiter before reactivation or replace temperature limiter
	Low voltage condition for more than 20 seconds	Check fuses, connections, and charge of battery.
	Switch-off caused by temperature limiter	After cool-down of unit, push button of temperature limiter before reactivation or replace temperature limiter.

Fig. 501 General Failure Symptoms

NOTE

In many cases the probable cause of failure may be the burner. Perform a visual inspection according to 5.4.

5.3 Failure Symptoms after Switch-off upon Failure

The heater Thermo 90 S with standard timer outputs errors to the timer display for indication (see 3.6.3). The following table may also be used as representative reference.

NOTE

When operated with a switch the type of failure is indicated by a flash code of the operation indicator light during heater run-down.

After five short signals the long flash pulses are counted.

Failure Symptom	Failure Symptom	Remedy
No function	Electrical wiring, fuses	Check fuses Check battery connections + at A5 / – at A3 / + from A1 (Thermo 90) + at 12 / – at 9 / + at 3, connector X12 (Thermo 90 S)
1 Flash pulse (no start)	Control unit defective	Replace control unit
	Fuel system	Check fuel level Check fuel filter Bleed fuel system
	Combustion air/exhaust duct	Check combustion air/exhaust duct for foreign matter and clean as required
2 Flash pulses (flame-out during operation)	Burner	Clean burner or replace as necessary
	Fuel supply	Check fuel level Check fuel filter Bleed fuel system
3 Flash pulses (low voltage)	Burner	Clean burner or replace as necessary
	Electrical power supply	Check battery Check electrical connections
4 Flash pulses (flame sensor continuously hot)	Flame sensor defective	Replace flame sensor
5 Flash pulses (flame sensor defective)	Wiring	Check wiring for damage, open connections or short circuit
	Flame sensor defective	Replace flame sensor
6 Flash pulses (temperature sensor defective)	Wiring	Check wiring for damage, open connections or short circuit
	Temperature sensor	Replace temperature sensor
7 Flash pulses (dosing pump defective / overheat protection defective)	Coolant circuit	Check coolant level Bleed coolant circuit Reset temperature limiter
	Wiring	Check wiring for damage, open connections or short circuit
	Dosing pump defective	Replace dosing pump

Fig. 502 Failure Symptoms after Switch-off upon Failure (Sheet 1 of 2)

Failure Symptom	Failure Symptom	Remedy
8 Flash pulses (combustion air fan defective)	Wiring	Check wiring for damage, open connections or short circuit
	Combustion air fan defective	Replace combustion air fan
9 Flash pulses (glow plug defective)	Wiring	Check wiring for damage, open connections or short circuit
	Glow plug defective	Replace glow plug

Fig. 502 Failure Symptoms after Switch-off upon Failure (Sheet 2 of 2)

5.4 Visual Inspection for Assessment of Burner Condition

Burner and evaporator have specific features indicating their need for replacement or their serviceable condition. The following describes the criteria for a correct inspection.

5.4.1 Burner Housing

- The starting air bore (Fig. 502) must not be clogged, otherwise there will be no start.

Remedy

Carefully remove any contamination (e.g. with a wire of 1.5 mm diameter). Remove glow plug first.

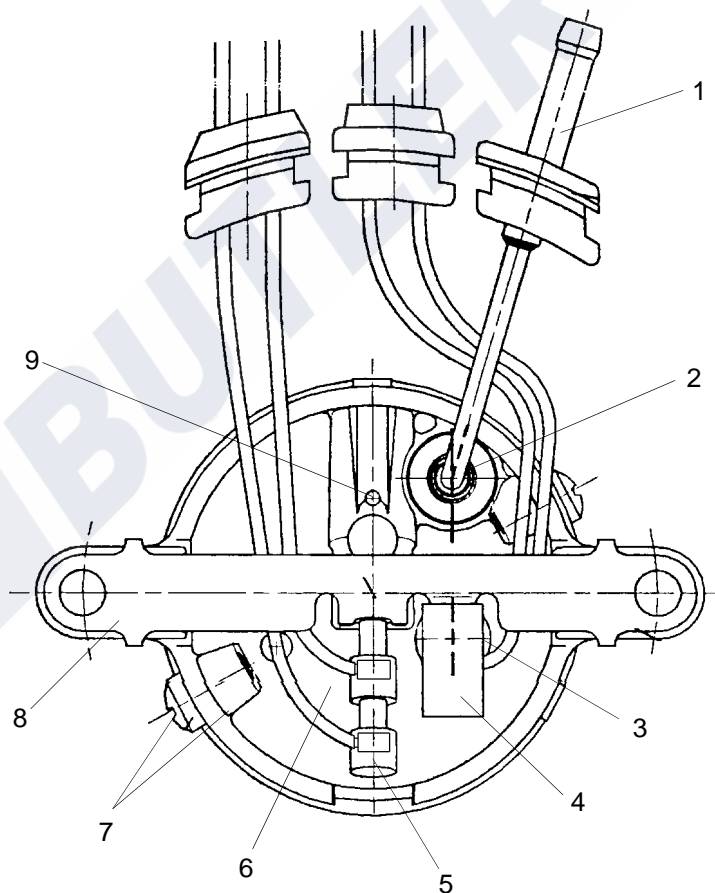

- 1 Combustion Tube
- 2 O-Ring
- 3 Flame Sensor
- 4 Insulation
- 5 Glow Plug
- 6 Housing
- 7 Screw
- 8 Bracket
- 9 Starting Air Bore

Fig. 503 Visual Inspection, Burner Real Wall

5.4.2 Rear Wall with Metal Evaporator

- The pilot flame exit bore (Fig. 504) must not be clogged, otherwise there will be no start.

Remedy

Replace burner

- Cracks, delaminations, as well as black or other discolorations of the evaporator do not cause a burner failure and are meaningless.
- Coke deposits on the evaporator surface (except for the pilot flame exit bore) are usual and must not be removed. When the load changes from full load to part load and vice versa the burner normally is self-cleaning.

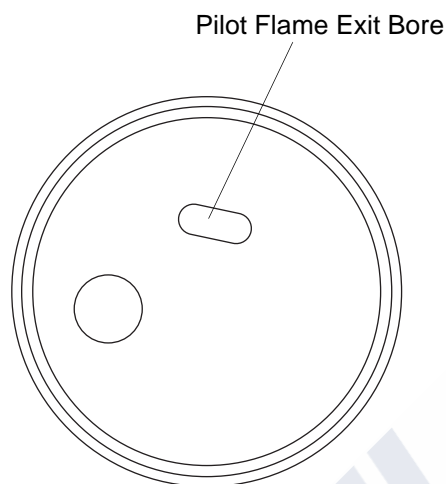

Metal Evaporator, Fuel

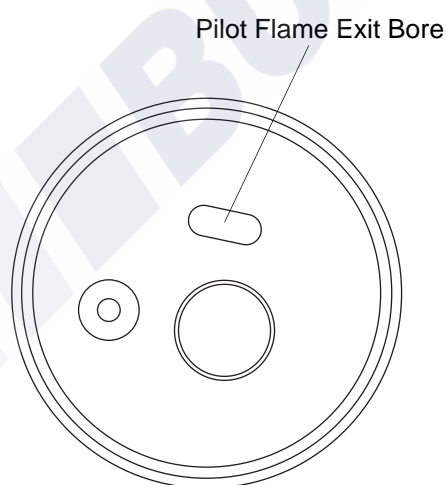

Metal Evaporator, Diesel

5.4.3 Combustion Chamber

- The combustion chamber (Fig. 505) should not be damaged (e.g. dented). A combustion chamber with dents may cause insufficient combustion or coking of the heater.

Remedy

Replace burner

- The air bores (Fig. 505) in the combustion chamber must not be coked. Coked air bores may cause a no-start or insufficient combustion.

Remedy

Removal of coke deposits by careful scraping.

5.4.4 Burner Assembly

- The cables of glow plug and flame sensor must be routed as shown in Fig. 503.
- The screwed connection of the housing and combustion chamber must be secure (Fig. 505).
- Housing and combustion chamber (Fig. 505) must be connected securely without any play (check by slight movement of fuel pipe).
- The O-ring must have a tight fit around the fuel chamber upper edge (Fig. 503) and must seal completely.
- The gap between housing edge and combustion chamber upper edge (Fig. 505) must not be equal around the entire circumference.
- The insulation (Fig. 503) must be present.

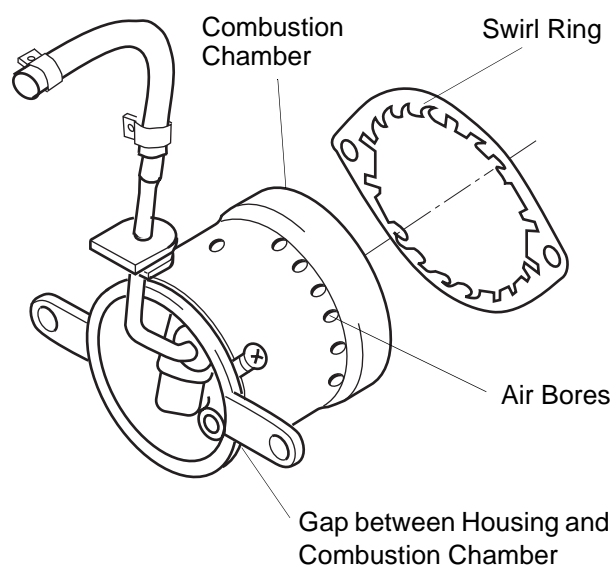

Fig. 505 Visual Inspection, Burner Assembly

Fig. 504 Visual Inspection, Pilot Flame Exit Bore

6 Functional Tests

6.1 General

This section describes the on-vehicle and off-vehicle testing of the heater to check its proper operation.

WARNING

The heater shall not be operated in enclosed areas like garages or workshops not provided with exhaust venting facilities.

6.2 Adjustments

6.2.1 Adjustment of the CO₂ Contents

A change of the combustion air volume set by the manufacturer may be performed by rotating the air set screw.

Setting Procedure

Clockwise rotation: CO₂ value decreases (prior to measurement; heater must have been in operation for at least 5 min).

Coarse setting: Rotate air set screw clockwise fully in and then back one turn.

6.3 Components Testing

6.3.1 Temperature Sensor Resistance Check

During electrical testing of the temperature sensor using a digital multimeter, the following readings should be obtained:

Resistance at 25° C:	990 ... 1010 Ω
Test current:	< 1 mA

6.3.2 Glow Plug Resistance Test

During electrical testing of the glow plug using a digital multimeter, the following readings should be obtained:

Glow plug:	12 Volt (red)	24 Volt (green)
Resistance at 25° C:	0.3 ... 0.6 Ω	1.3 ... 1.44 Ω
Test current:	< 5 mA	< 5 mA

6.3.3 Flame Sensor Resistance Test

During electrical testing of the flame sensor using a digital multimeter, the following readings should be obtained:

Cold test:

Resistance at 25° C:	2.6 ... 3.4 Ω
Test current:	< 5 mA

Hot test:

Resistance at 800 – 1000° C:	12 ... 15 Ω
(ceramic rod red hot over a length of approx. 20 mm)	
Test current:	< 5 mA

6.3.4 Combustion Air Fan Test

The motor speed check must be performed with the heater assembled and within the operating voltage range. During the test check for grinding noises.

NOTE

For the motor speed check the fan cover must be removed. Prior to re-installation the gasket is to be renewed.

CAUTION

Pay attention not to break off the locking cams, otherwise renew cover and gasket.

Speed in control range min.	1800 min ⁻¹	(± 9%)
Speed in control range max.	6100 min ⁻¹	(± 9%)

In case speed values are out of tolerance replace combustion air fan (see 9.2.5).

NOTE

On the Thermo 90 the function of the combustion air fan can be checked with the diagnostic computer or the components tester.
On the Thermo 90 S the check is performed by means of the PC heater diagnosis.

BUTLER TECHNIK

7 Circuit Diagrams

7.1 General

The circuit diagrams (Figs. 702 and 703) show possible circuits of the heater Thermo 90 with

- 3-times-clock
- TRS equipment

The circuit diagrams (Figs. 704 through 706) show possible circuits of the heater Thermo 90 S with

- standard timer
- TRS equipment
- TRS equipment without auxiliary drive

Fig. 701 shows the pin assignment (X1) for Thermo 90 and Thermo 90 S.

CAUTION

The –poles must not be looped or reversed as some components are controlled by negative polarity.

- 1 = Glow Plug +
- 2 = Temperature Limiter +
- 3 = Flame Sensor +
- 4 = Temperature Sensor +
- 5 = Circulation Pump +
- 6 = Combustion Air Fan +
- 7 = Combustion Air Fan –
- 8 = Circulation Pump –
- 9 = Temperature Sensor –
- 10 = Flame Sensor –
- 11 = Temperature Limiter –
- 12 = Glow Plug –

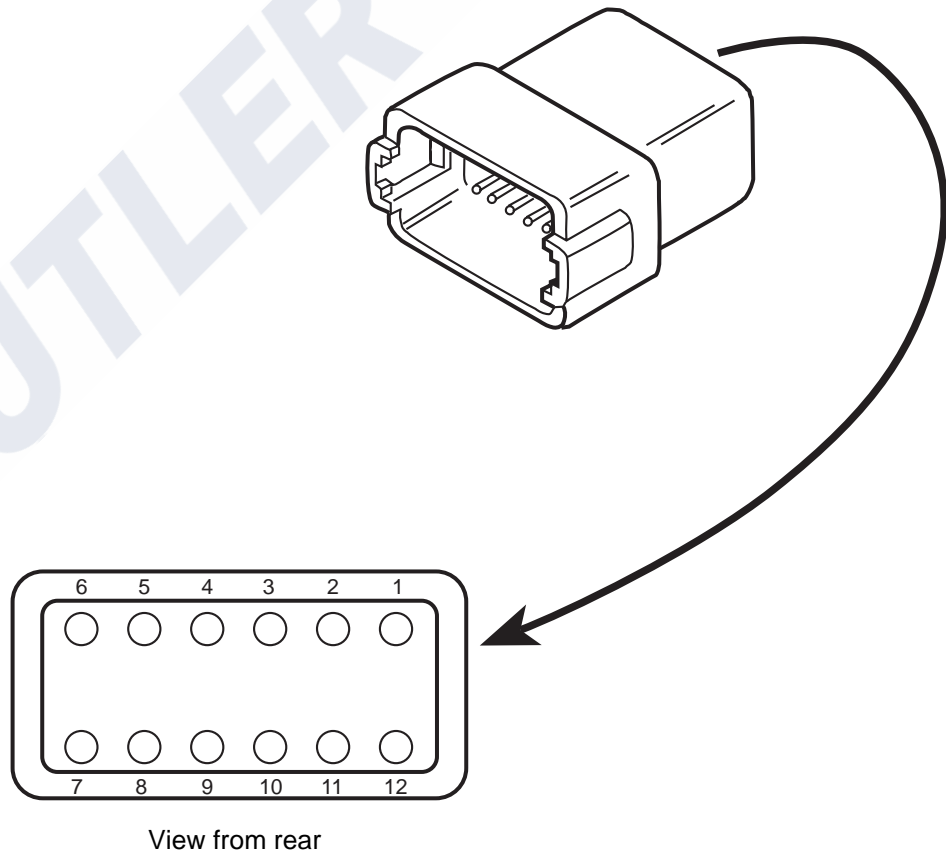
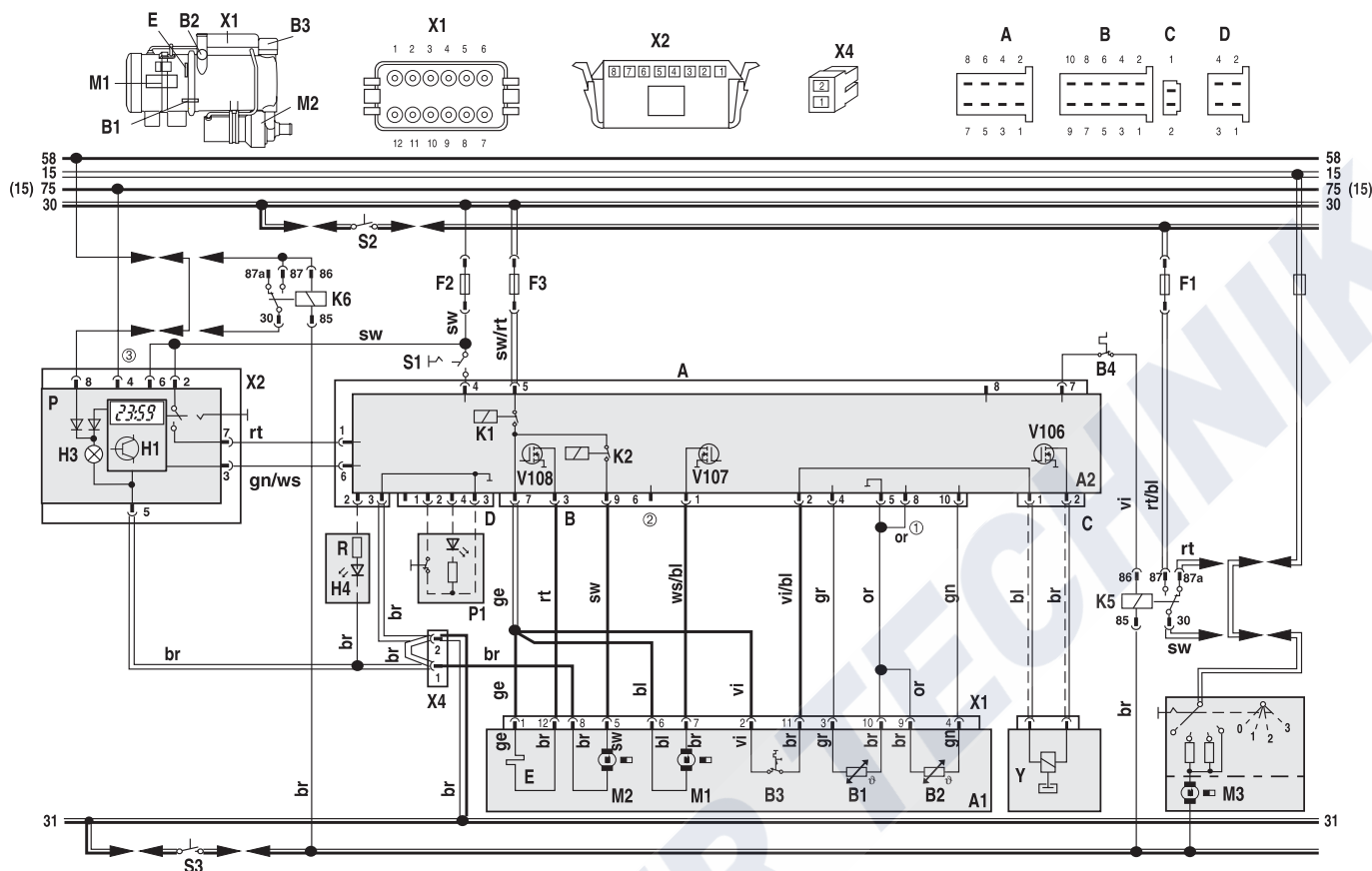

Fig. 701 Pin Assignment

7 Circuit Diagrams

DW80



- ① For fuel heaters remove this connection
- ② Temperature coding (temperature at water outlet): see table page 302
- ③ Timer P:
with plus at connection 4 = permanent operation in immediate heating
without plus at connection 4 = heating period 1 hour

Wire gauges	
	< 7.5 m
	7.5 - 15 m
	0.75 mm ²
	1.5 mm ²
	1.0 mm ²
	1.5 mm ²
	2.5 mm ²
	2.5 mm ²
	4.0 mm ²
	4.0 mm ²
	6.0 mm ²

Wire colors	
bl	blue
br	brown
ge	yellow
gn	green
gr	gray
or	orange
rt	red
sw	black
vi	violet
ws	white

Item	Nomenclature	Remark
A1	Heater	Thermo 90
A2	Control Unit	SG 1569
B1	Flame Sensor	
B2	Temperature Sensor	
B3	Temperature Limiter	
B4	Room Thermostat	
E	Glow Plug	
F1	Fuse 20 A	Flat Fuse SAE J 1284
F2	Fuse 5 A	Flat Fuse SAE J 1284
F3	Fuse 20 A	Flat Fuse SAE J 1284
H1	Symbol for "Heating" in Display	Operation indication (in item P)
H3	Light	Symbol illumination (in item P)
H4	LED	max. 20 mA Flame indication (option)
K1	Relay (in item A2)	Master relay
K2	Relay (in item A2)	for circulation pump
K5	Relay	for vehicle blower
K6	Relay	only required for battery switch in minus

Item	Nomenclature	Remark
M1	Motor	Combustion air fan
M2	Motor	Circulation pump
M3	Motor	Vehicle blower
P1	Test Unit	for diagnosis
P	Timer 1529	for pre-timed operation
R	Resistor	Resistor for H4
S1	Switch for Circulation Pump	for separate switch-on
S2	Switch	Battery switch in plus
S3	Switch	Battery switch in minus
V106	Transistor	in item A2
V107	Transistor	in item A2
V108	Transistor	in item A2
X1	Connection 12-pole	on item A1
X2	Connection 8-pole	on item P
X4	Connection 2-pole	
Y	Dosing Pump	

Fig. 702 Circuit Diagram Automatic Control for Thermo 90, 12 and 24 V with Triple Timer

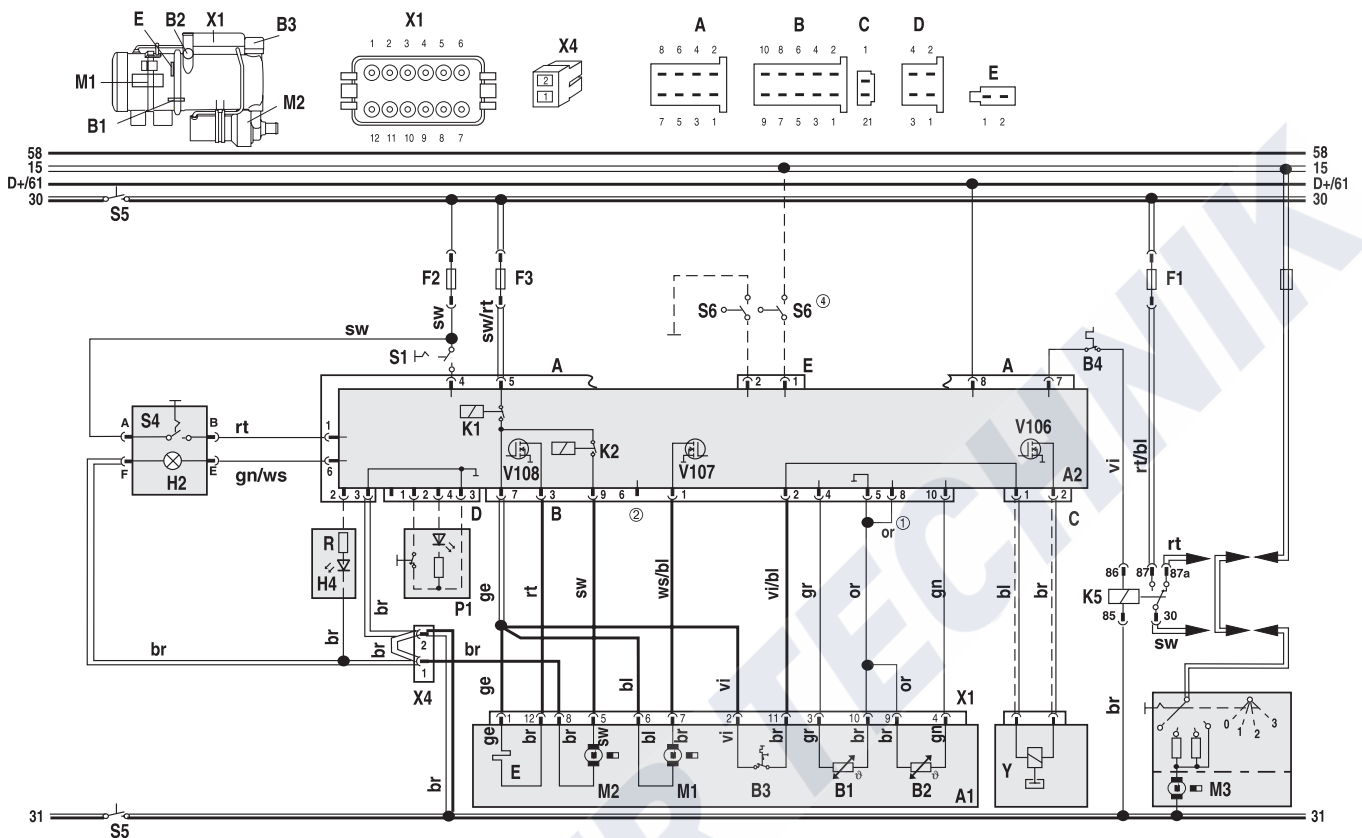

- ① For fuel heaters remove this connection
- ② Temperature coding (temperature at water outlet): see table page 302
- ③ Switch S6 must be installed so that plus or minus potential is applied to the relevant control inputs of the control unit when a conveyor facility is put into operation.

Wire gauges		
	< 7.5 m	7.5 - 15 m
	0.75 mm ²	1.5 mm ²
	1.0 mm ²	1.5 mm ²
	1.5 mm ²	2.5 mm ²
	2.5 mm ²	4.0 mm ²
	4.0 mm ²	6.0 mm ²

Wire colors	
bl	blue
br	brown
ge	yellow
gn	green
gr	gray
or	orange
rt	red
sw	black
vi	violet
ws	white

Item	Nomenclature	Remark
A1	Heater	Thermo 90
A2	Control Unit	SG 1569
B1	Flame Sensor	
B2	Temperature Sensor	
B3	Temperature Limiter	
B4	Room Thermostat	
E	Glow Plug	
F1	Fuse 20 A	Flat Fuse SAE J 1284
F2	Fuse 5 A	Flat Fuse SAE J 1284
F3	Fuse 20 A	Flat Fuse SAE J 1284
H2	Light in item S4	Operation indication (max. 2 W)
H4	LED	max. 20 mA Flame indication (option)
K1	Relay (in item A2)	Master relay
K2	Relay (in item A2)	for circulation pump
K5	Relay	for vehicle blower
M1	Motor	Combustion air fan
M2	Motor	Circulation pump
M3	Motor	Vehicle blower

Item	Nomenclature	Remark
P1	Test Unit	for diagnosis
R	Resistor	Resistor for H4
S1	Switch for Circulation Pump	for separate switch-on
S4	Switch	ON / OFF
S5	Isolation Switch 1-pole or 2-pole	Emergency off switch electr. or pneum.
S6	Switch on Conveyor Facility	to plus or minus
V106	Transistor	in item A2
V107	Transistor	in item A2
V108	Transistor	in item A2
X1	Connection 12-pole	on item A1
X4	Connection 2-pole	
Y	Dosing Pump	

Fig. 703 Circuit Diagram Automatic Control Thermo 90-TRS, 24 V

7 Circuit Diagrams

DW80

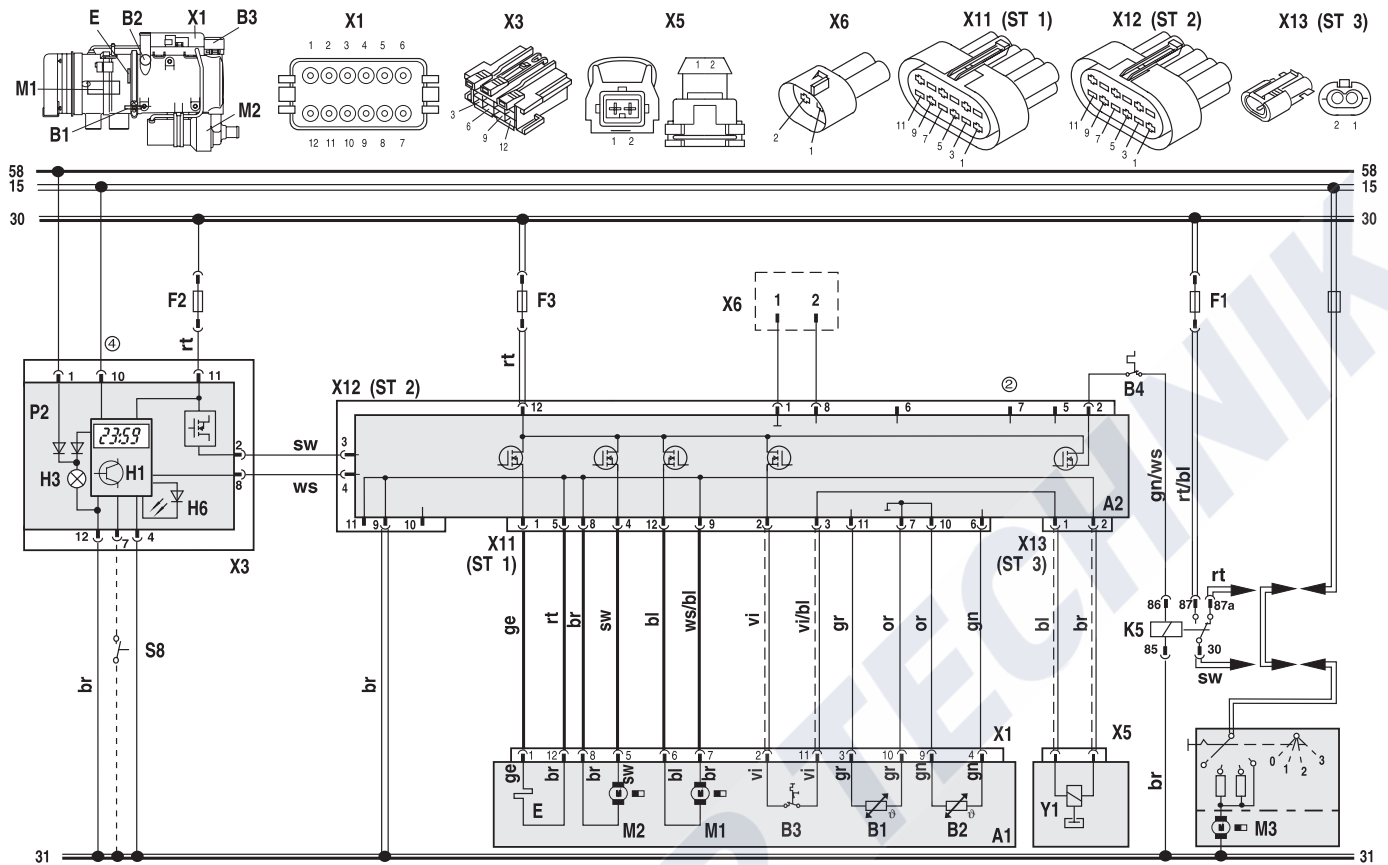

② Temperature coding (temperature at water outlet): see table page 302

④ Timer P2:
 with plus at connection 10 = permanent operation in instant heating
 without plus at connection 10 = heating period programmable (10 min to 120 min); basic setting 120 min

Wire gauges	
< 7.5 m	7.5 - 15 m
0.75 mm ²	1.5 mm ²
1.0 mm ²	1.5 mm ²
1.5 mm ²	2.5 mm ²
2.5 mm ²	4.0 mm ²
4.0 mm ²	6.0 mm ²

Wire colors	
bl	blue
br	brown
ge	yellow
gn	green
gr	gray
or	orange
rt	red
sw	black
vi	violet
ws	white

Item	Nomenclature	Remark
A1	Heater	Thermo 90 / Thermo 90 S
A2	Control Unit	
B1	Flame Sensor	
B2	Temperature Sensor	
B3	Temperature Limiter	
B4	Room Thermostat	
E	Glow Plug	
F1	Fuse 20 A	Flat Fuse SAE J 1284
F2	Fuse 5 A	Flat Fuse SAE J 1284
F3	Fuse 20 A	Flat Fuse SAE J 1284
H1	Symbol for "Heating" in Display	Operation indication (in item P1 or P2)
H3	Light	Symbol illumination (in item P1 or P2)
H6	LED red (in item P2)	Illumination instant heat switch, standby indication, on indication
K5	Relay	for vehicle blower
M1	Motor	Combustion air fan
M2	Motor	Circulation pump
M3	Motor	Vehicle blower

Item	Nomenclature	Remark
P2	Standard Timer (1531)	for pre-timed operation
S8	Switch Button	Instant heat switch remote control
X1	Connection 12-pole	on item A1
X3	Connection 12-pole	on item P2
X5	Connection 2-pole	
X6	Connection 2-pole	Diagnosis
X11	Connection 12-pole	on item A2 (ST 1)
X12	Connection 12-pole	on item A2 (ST 2)
X13	Connection 2-pole	on item A2 (ST 3)
Y1	Dosing Pump	

Fig. 704 Circuit Diagram Automatic Control for Thermo 90 S, 12 and 24 V with Standard Timer

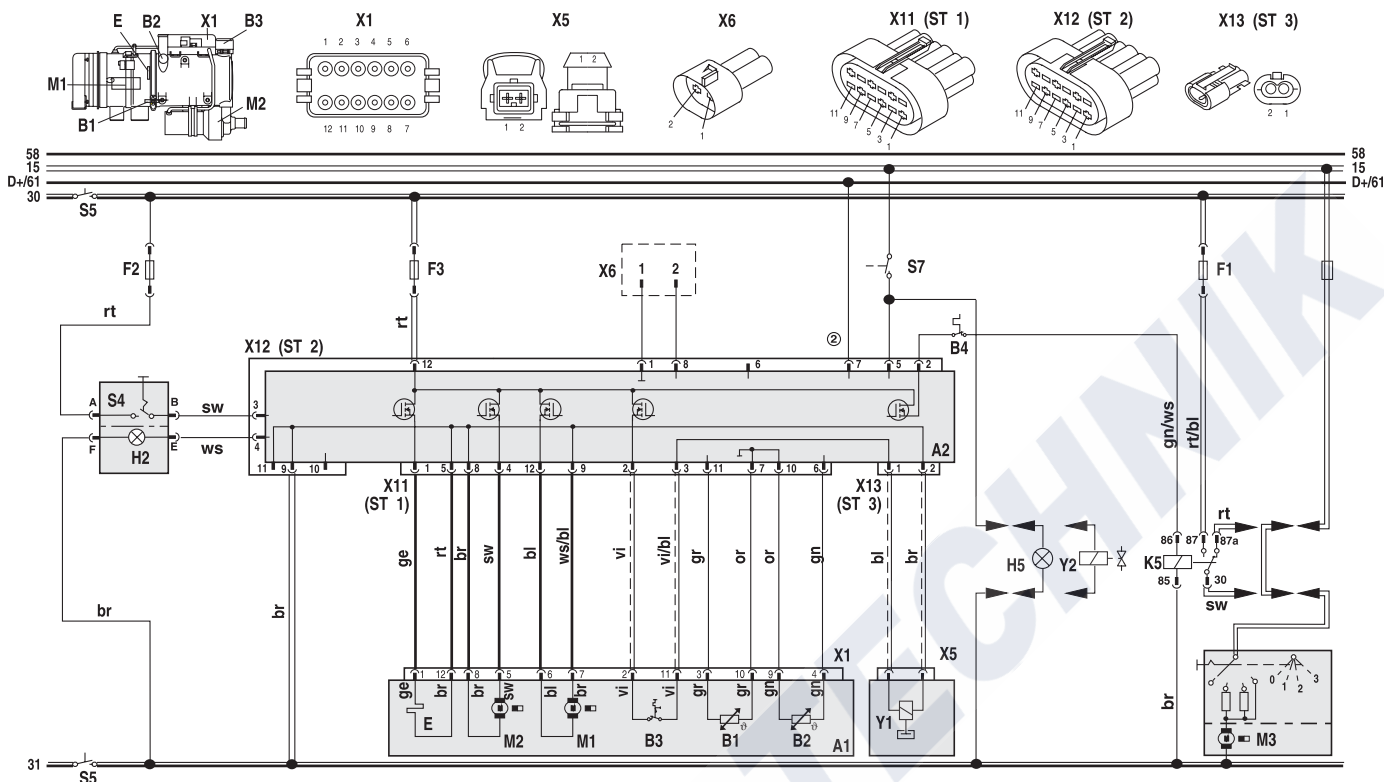

② Temperature coding (temperature at water outlet): see table page 302

Wire gauges		
	< 7.5 m	7.5 - 15 m
	0.75 mm ²	1.5 mm ²
	1.0 mm ²	1.5 mm ²
	1.5 mm ²	2.5 mm ²
	2.5 mm ²	4.0 mm ²
	4.0 mm ²	6.0 mm ²

Wire colors	
bl	blue
br	brown
ge	yellow
gn	green
gr	gray
or	orange
rt	red
sw	black
vi	violet
ws	white

Item	Nomenclature	Remark
A1	Heater	Thermo 90 / Thermo 90 S
A2	Control Unit	
B1	Flame Sensor	
B2	Temperature Sensor	
B3	Temperature Limiter	
B4	Room Thermostat	
E	Glow Plug	
F1	Fuse 20 A	Flat Fuse SAE J 1284
F2	Fuse 5 A	Flat Fuse SAE J 1284
F3	Fuse 20 A	Flat Fuse SAE J 1284
H2	Light in item S4	Operation indication (max. 2 W)
H5	Lamp, at least 1.2 W	On indication conveyor equipment
K5	Relay	for vehicle blower
M1	Motor	Combustion air fan
M2	Motor	Circulation pump
M3	Motor	Vehicle blower
S4	Switch	ON / OFF
S5	Isolation Switch 1-pole or 2-pole	Emergency off switch electr. or pneum.

Item	Nomenclature	Remark
S7	Switch conveyor equipment	to Plus
X1	Connection 12-pole	on item A1
X5	Connection 2-pole	
X6	Connection 2-pole	Diagnosis
X11	Connection 12-pole	on item A2 (ST 1)
X12	Connection 12-pole	on item A2 (ST 2)
X13	Connection 2-pole	on item A2 (ST 3)
Y1	Dosing Pump	
Y2	Solenoid valve	for conveyor equipment

Fig. 705 Circuit Diagram Automatic Control for Thermo 90 S-TRS, 24 V

7 Circuit Diagrams

DW80

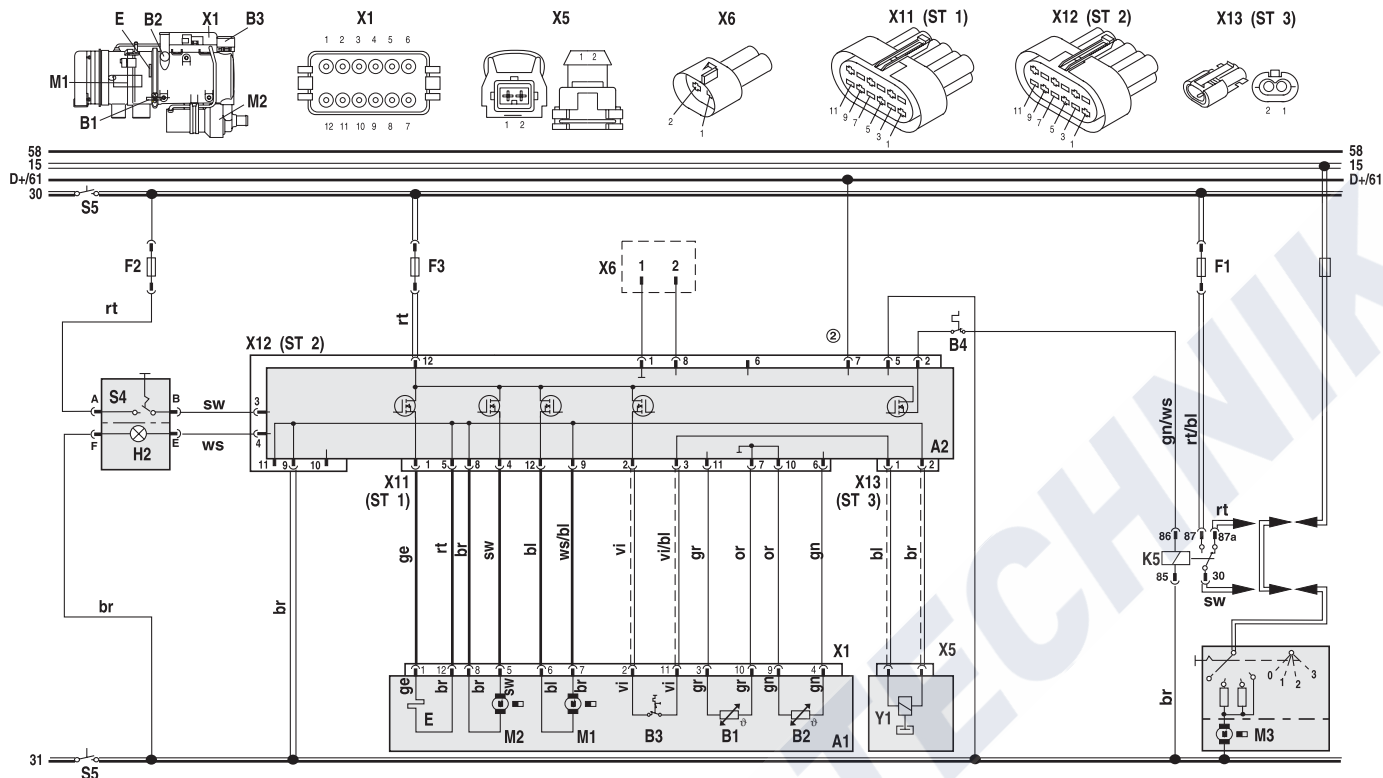

② Temperature coding (temperature at water outlet): see table page 302

Wire gauges		
	< 7.5 m	7.5 - 15 m
	0.75 mm ²	1.5 mm ²
	1.0 mm ²	1.5 mm ²
	1.5 mm ²	2.5 mm ²
	2.5 mm ²	4.0 mm ²
	4.0 mm ²	6.0 mm ²

Wire colors	
bl	blue
br	brown
ge	yellow
gn	green
gr	gray
or	orange
rt	red
sw	black
vi	violet
ws	white

Item	Nomenclature	Remark
A1	Heater	Thermo 90 / Thermo 90 S
A2	Control Unit	
B1	Flame Sensor	
B2	Temperature Sensor	
B3	Temperature Limiter	
B4	Room Thermostat	
E	Glow Plug	
F1	Fuse 20 A	Flat Fuse SAE J 1284
F2	Fuse 5 A	Flat Fuse SAE J 1284
F3	Fuse 20 A	Flat Fuse SAE J 1284
H2	Light in item S4	Operation indication (max. 2 W)
K5	Relay	for vehicle blower
M1	Motor	Combustion air fan
M2	Motor	Circulation pump
M3	Motor	Vehicle blower
S4	Switch	ON / OFF
S5	Isolation Switch 1-pole or 2-pole	Emergency off switch electr. or pneum.

Item	Nomenclature	Remark
X1	Connection 12-pole	on item A1
X5	Connection 2-pole	
X6	Connection 2-pole	Diagnosis
X11	Connection 12-pole	on item A2 (ST 1)
X12	Connection 12-pole	on item A2 (ST 2)
X13	Connection 2-pole	on item A2 (ST 3)
Y1	Dosing Pump	

Fig. 706 Circuit Diagram Automatic Control for Thermo 90 S-TRS, 24 V without Auxiliary Drive

8 Servicing

8.1 General

This section describes the servicing procedures that may be performed with the heater installed.

8.2 Work on the Heater

Prior to performing any work, it is mandatory to disconnect the vehicle battery main lead. As long as the heater is in operation or in run-down, the battery main supply must not be disconnected due to the danger of overheating resulting in a response of the overheat protection. When performing extensive repairs on the heater, a complete removal is advisable. After work on the heating circuit, a coolant mixture consisting of water and anti-freeze must be replenished in accordance with manufacturer instructions followed by a careful bleeding of the heating circuit.

When performing repairs requiring a relocation of the installation position, the relevant installation instructions and the vehicle-specific installation proposal have to be observed.

8.3 Work on the Vehicle

CAUTION

In the vicinity of the heater, a temperature of 130° C must not be exceeded under any circumstances (e.g. during body paint work).

8.4 Heater Test Run

WARNING

The heater must not be operated, not even with timer, in enclosed areas like garages or workshops not equipped with an exhaust venting facility.

8.5 Servicing

Before or after each heating season the following servicing should be performed to maintain the heater's functional reliability:

- Clean heater exterior (prevent the ingress of water).
- Examine electrical connections for corrosion of contacts and for security.
- Check exhaust combustion air lines for damage and for foreign matter and contamination.
- Check fuel lines and fuel filter for leakage.
- Check coolant circuit and circulation pump for leakage.
- Check hoses for cracks.
- Replace fuel filter if installed.

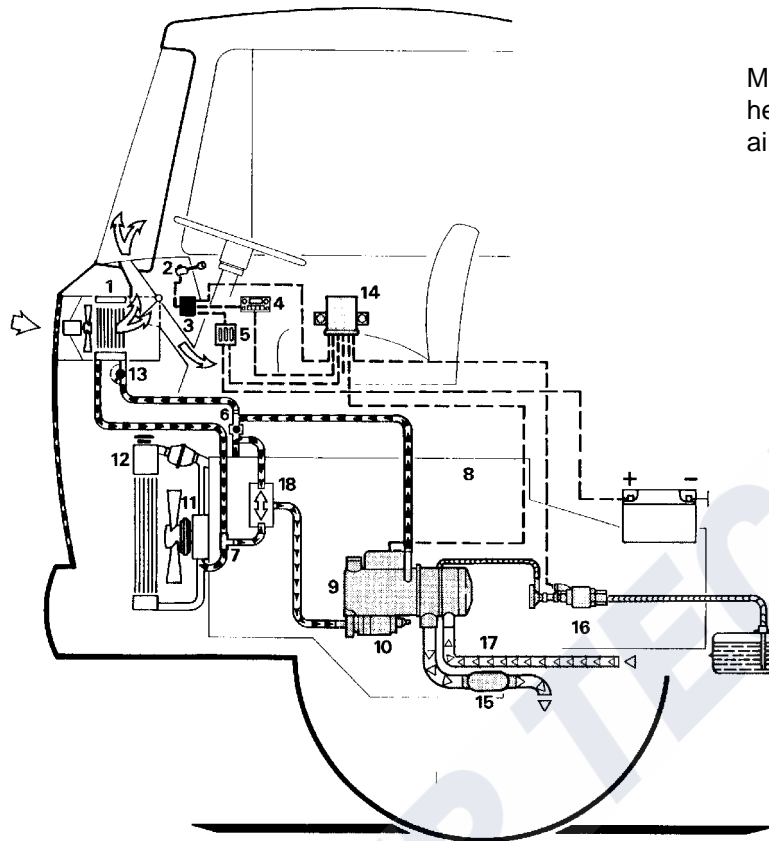

With Check Valve and Thermostat

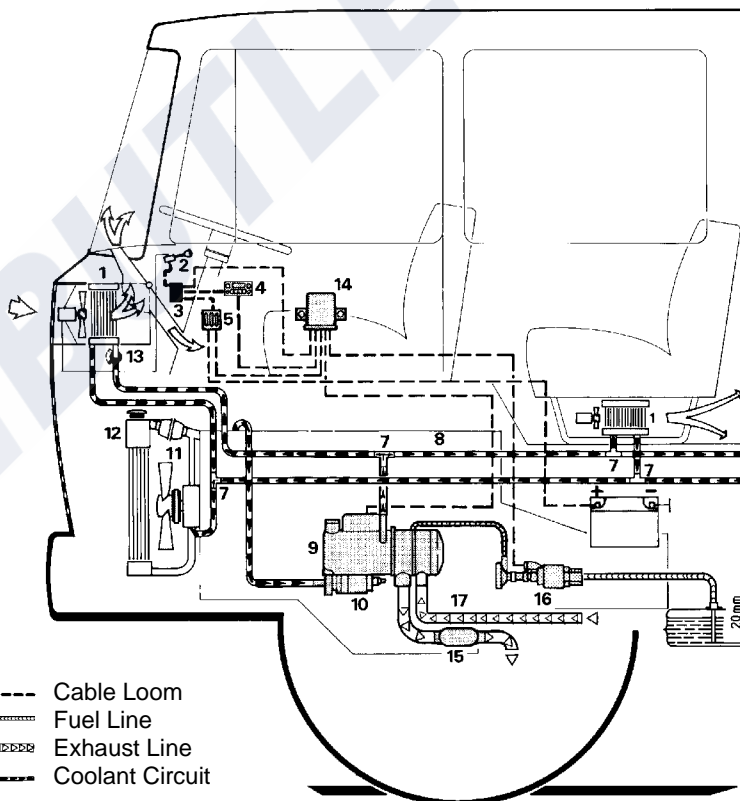

Without Check Valve

NOTE

Manufacturer mounts control unit of heaters Thermo 90 S to combustion air fan.

- Cable Loom
- Fuel Line
- Exhaust Line
- Coolant Circuit

- 1 Heat Exchanger, Vehicle Heating System
- 2 Blower Switch Vehicle Heating System
- 3 Relay for Vehicle Blower
- 4 Timer
- 5 Fuse Box in Vehicle
- 6 Check Valve with Drain Hole
- 7 T-Junction
- 8 Vehicle Engine
- 9 Heater Unit
- 10 Circulation Pump
- 11 Water Pump
- 12 Radiator
- 13 Regulating Valve
- 14 Control Unit
- 15 Exhaust Muffler
- 16 Dosing Pump
- 17 Combustion Air Intake Line
- 18 Thermostat

Fig. 801 Example for Heater Installation in Lorry

8.6 Visual Inspections and Installation Regulations

8.6.1 Connection to the Vehicle's Cooling System

In thermostat circuits only thermostats opening at < 65° C are to be used.

The installation of the heater should be in a location as low as possible to ensure self-venting of the heater and circulation pump. This applies in particular for the circulation pump, which is not self-sucking.

The heater is to be connected to the cooling system according to Fig. 801. The amount of coolant in the cooling system must be at least 6 litres.

As a rule, the coolant hoses supplied by Webasto together with the heater are to be used. Otherwise the hoses must at least meet the requirements of DIN 73411. The hoses must be routed without kinking, and for proper venting where possible in an upwards direction.

Hose connections must be secured with hose clamps to prevent slippage.

NOTE

Hose clamps must be torqued to 1.5 Nm (clamps previously in use) or to 5.0 Nm (new, wide clamps).

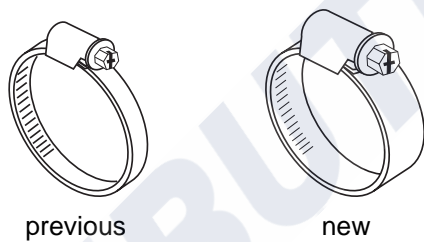

Prior to first operation of the heater or after replacement of the coolant, bleed the cooling circuit. Heater and lines have to be installed so that a static venting is guaranteed.

Insufficient venting during heating operation may cause failure due to overheating.

Proper venting is indicated by a circulation pump almost noiseless in operation. Insufficient venting during heating operation may cause release of the resettable temperature limiter.

8.6.2 Connection to the Vehicle's Fuel System

Fuel is tapped from the fuel reservoir of the vehicle or from a separate fuel container.

The rated pressure at the fuel tapping location is shown in the following table.

Permissible fuel feed height H (m)	at max. permissible over-pressure (bar) in fuel tank
0.00	0.20
1.00	0.11
2.00	0.03
Permissible fuel suction height S (m)	at max. permissible low pressure (bar) in fuel tank
0.00	- 0.10
0.50	- 0.06
1.00	- 0.02

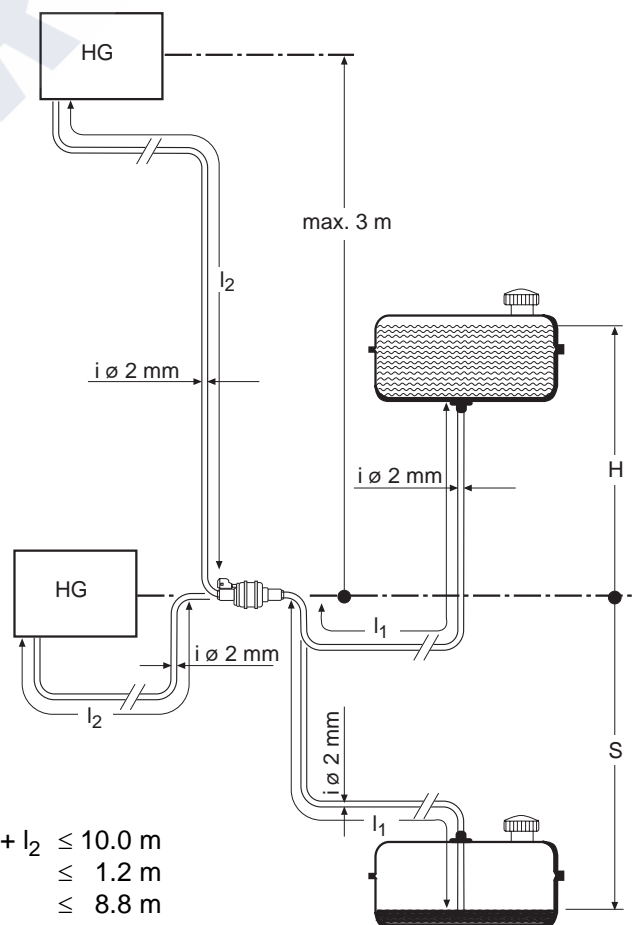

Fig. 802 Fuel Supply

8.6.2.1 Fuel Tapping

Fuel tapping must be from the fuel reservoir or from a separate tank (Figs. 803, 804, and 805). This separate fuel tapping avoids an influence on the pressure.

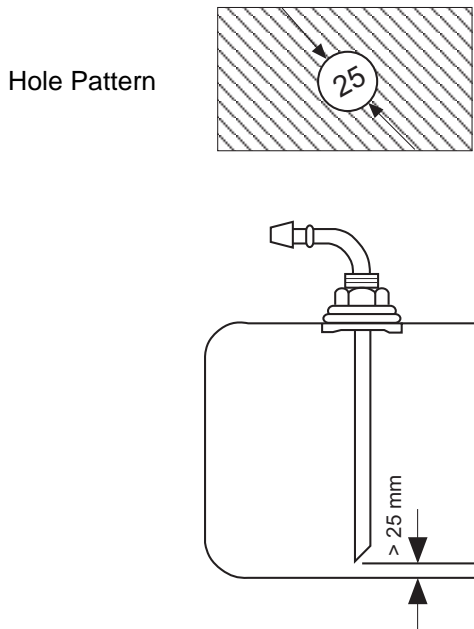

Fig. 803 Webasto Fuel Tank Tap

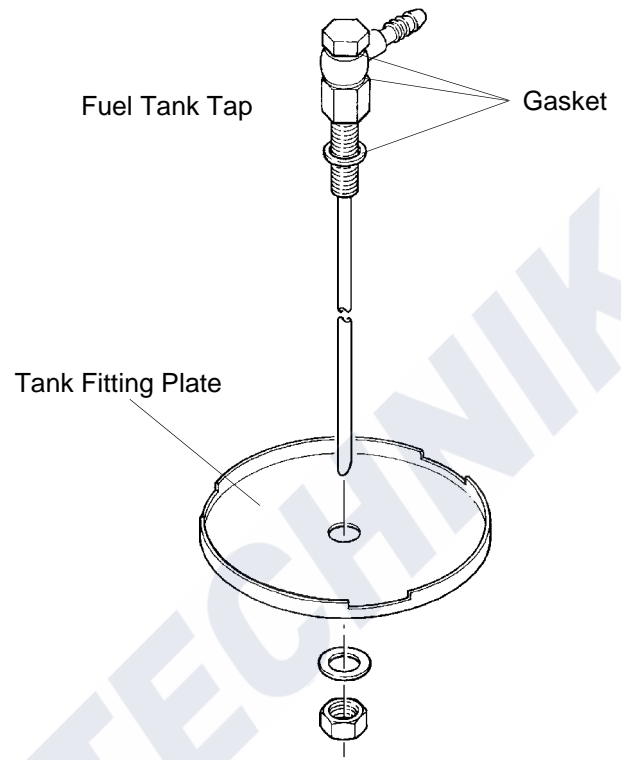

Fig. 805 Fuel Tapping from Plastic Tank (tapping via fitting plate)

* Use fuel tank tap only on metal fuel tanks

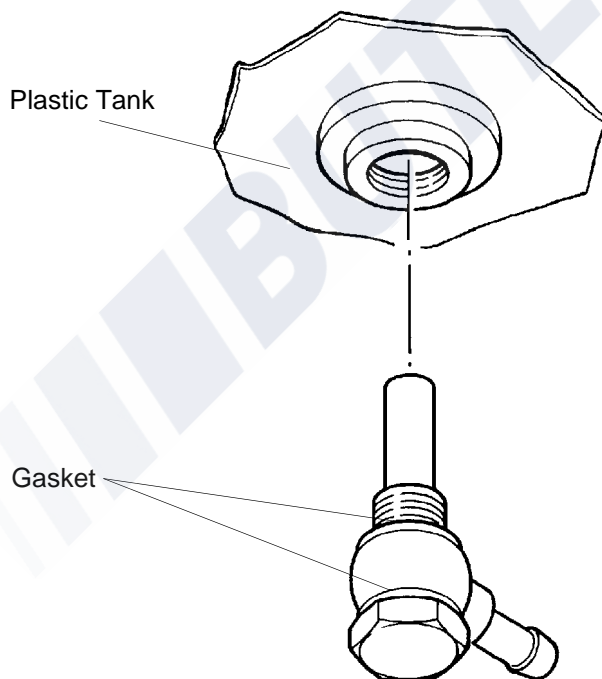

Fig. 804 Fuel Tapping from Plastic Tank (tapping via fuel drain plug)

NOTE

The fitting plate must be made of sheet metal.

Vehicles with Fuel Engines

In combination with carburettor or fuel injection engines with return line the heater's fuel system integration must be in the return.

Carburettor engines without return line must have the heater integrated in the fuel supply between the vehicle's fuel tank and fuel pump.

NOTE

- A fuel supply line can normally be identified by an installed fuel filter.
- If an exhalation vessel is installed in the vehicle's fuel system, fuel tapping must be upstream of the exhalation vessel.

For fuel tapping from the supply or return line only the specific Webasto fuel tap, e.g. Ident. No. 470 910 for Ø 8 mm may be used. The fuel tap must be mounted so that the air or gas bubbles can escape towards the fuel tank. Air or gas bubbles may build up in the vehicle fuel line in case of a leak in the vehicle's carburettor or fuel pump or when environmental temperatures are higher than the fuel evaporation temperature.

The fuel tap should not be located in the engine compartment because the radiation of engine heat may cause gas bubbles to build up in the fuel lines causing malfunctions in the combustion operation.

When installing the heater in vehicles with fuel injection system the fuel pump's location within or outside the fuel tank must be investigated first.

If the fuel pump is fitted inside the fuel tank, the fuel may be tapped only from the return line ensuring that the return line is routed almost to the tank floor. If this is not the case the fuel line may be lengthened.

In case of a fuel pump mounted externally to the tank the fuel tap can be located between fuel tank and fuel pump.

8.6.2.2 Fuel Lines

Fuel lines may only be steel, copper, or plastic lines made of unhardened, light and temperature stabilised PA 11 or PA 12 (e.g. Mecanyl RWTL) according to DIN 73378. As in most cases a permanently rising fuel line routing cannot be ensured, the inner diameter must not exceed a certain value. Starting from an inside diameter of 4 mm, air or gas bubbles accumulate resulting in malfunctions should the lines be descending or having sags. The diameters specified in Fig. 802 ensure a non-accumulation of air bubbles.

A descending line routing from the dosing pump to the heater should be avoided.

Loose fuel lines must be secured in order to avoid sagging. The installation must ensure protection against stone impacts and **undue temperatures** (exhaust line).

The fuel line joints are to be secured against loosening with hose clamps.

Connection of 2 Pipes with Hose

The proper connection of fuel lines with hoses is shown in Fig. 806.

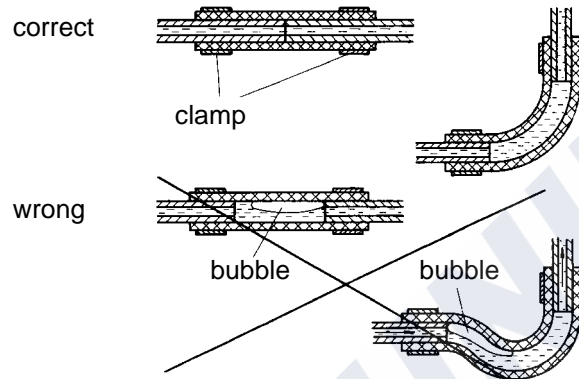
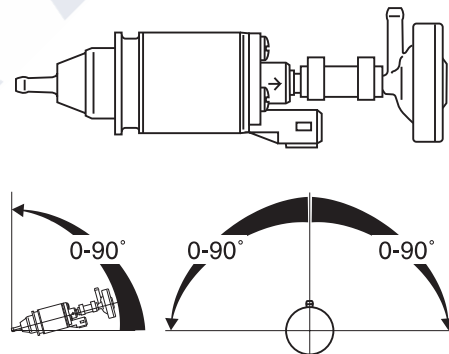

Fig. 806 Pipe/Hose Connection

8.6.3 Dosing Pump

The dosing pump is a combined delivery, dosing, and shut-off system and is subject to certain installation criteria (see Figs. 802 and 807).



Thermo 90, 12 Volt – Fuel

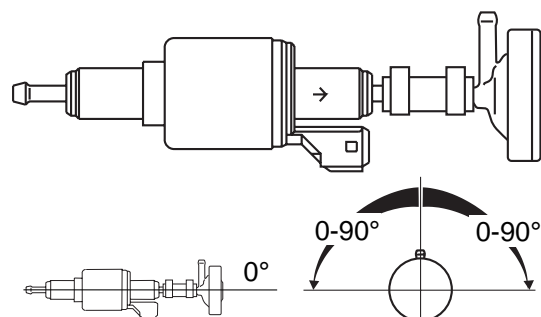

Thermo 90, 12 Volt and 24 Volt – Diesel DP 30
Installation Position Horizontal only

Fig. 807 Dosing Pump, Installation Location and Attachment

8.6.3.1 Installation Location

It is advantageous to mount the dosing pump in a cool location as near as possible to the tank. The ambient temperature must never exceed +20° C for fuel and +40° C for Diesel operated installations at any time while in operation. The maximum pressure at the tapping location must be below 1.5 bar.

Dosing pump and fuel lines must not be installed in locations exposed to heat radiated by hot vehicle components. A heat shield is to be provided as required.

8.6.3.2 Installation and Attachment

The dosing pump is to be attached with anti-vibration mounts. The installation location is limited according to Fig. 807 to ensure sufficient self-venting capability. Due to the danger of corrosion the plug connection between dosing pump and dosing pump cable loom may only use Webasto original parts.

8.6.4 Fuel Filter

If there is the probability of contaminated fuel, only the Webasto filter, Order No. 487 171, may be used. The filter can be installed anywhere between the vertical and horizontal positions, but must be installed in the direction of flow.

8.6.5 Combustion Air Supply

Combustion air must under no circumstances be extracted from rooms with persons. The combustion air inlet must not point towards the forward direction of motion. It must be located so that no clogging by contamination, impact of snow, or intake of splash water is possible.

The combustion air intake line (inner diameter at least 30 mm) may have a length from 0.5 m to 5 m with several bends of a total of 360°. Smallest bending radius is 45 mm.

The combustion air inlet must not be located above the exhaust outlet.

NOTE

The combustion air intake line is to be routed in a downwards direction. If this is not possible, a water drain hole (4 mm Ø) must be provided at the lowest point.

If the heater is located near the fuel tank in a common installation compartment, combustion air must be taken in from, and the exhaust routed to, the exterior. The feed-throughs must be splash waterproof.

If the heater is located in a closed installation box, a vent port of at least 6 cm² is required. If the temperature in the installation box exceeds the permitted ambient temperature of the heater (see Technical Data), the vent port must be enlarged consulting Webasto.

8.6.6 Exhaust Line

The exhaust line (inner diameter 38 mm) may have a length from 0.5 m to 5 m and be routed with several bends (a total of 360°, smallest bending radius 85 mm). The exhaust muffler is mandatory and to be mounted near the heater.

In order to ensure the angle of 90° ± 10°, an attachment is required not further than 150 mm away measured from the exhaust pipe end.

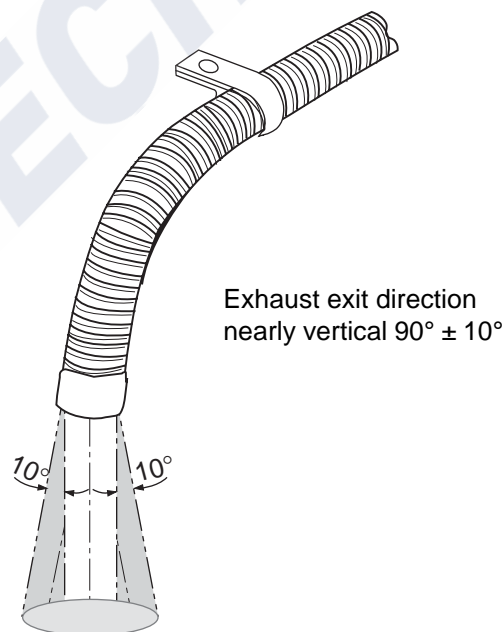

Fig. 808 Exhaust Muffler, Direction of Flow

The exhaust pipe outlet opening must not point in the direction of motion (see Fig. 808).

The exhaust pipe outlet opening must be located so as not to allow clogging by snow or mud.

Rigid exhaust-line pipes can be made of unalloyed or alloyed steel, but must have a minimum wall thickness of 1.0 mm. Flexible exhaust pipes must be made only of alloyed steel. The exhaust pipe is secured to the air heater with a clamp. For further requirements refer to official regulations.

For Thermo 90 TRS only: For official regulations concerning the exhaust pipe installation refer to Technical Information E3 - 5.10 (Order No. 776 623).

8.7 Removal and Installation

CAUTION

In installed condition, only the following removal and disassembly procedures are allowed as long as the top cover is accessible for removal and sufficient space for removal is available:

- replacement of circulation pump
- replacement of temperature limiter
- replacement of temperature sensor
- replacement of combustion air fan
- replacement of control unit (Thermo 90 S)

8.7.1 Heater, Removal and Installation

8.7.1.1 Removal

1. Disconnect battery terminal leads.

NOTE

On heater Thermo 90 S with control unit flanged to combustion air fan only connectors X12 and X13 require disconnection from control unit.

2. Remove top cover.
3. Disconnect plug of cable loom from heater.
4. Disconnect fuel inlet on heater.
5. Loosen hose clamps and disconnect coolant hoses from heater.
6. Disconnect connections of combustion air intake and exhaust outlet on heater.
7. Remove three nuts and washers from heater mount.
8. Remove heater.

8.7.1.2 Installation

1. Locate heater in installation position and secure with three nuts and washers.
2. Reconnect coolant hoses and secure with hose clamps. Torque tighten clamps with 5 Nm.
3. Secure connection for fuel inlet on heater.
4. Secure connections for combustion air inlet and exhaust outlet on heater.

NOTE

On heater Thermo 90 S with control unit flanged to combustion air fan reconnect connectors X12 and X13 to control unit.

5. Connect plug of cable loom to heater.
6. Plug on top cover and arrest.
7. Reconnect battery terminal leads.
8. Bleed fuel supply system.
9. Bleed coolant circuit.

8.7.2 Replacement of Circulation Pump

NOTE

The procedure for replacement of the circulation pump is identical with the heater removed or installed. Replacement is to be performed in accordance with 9.2.2.

8.7.3 Replacement of Temperature Limiter

NOTE

The procedure for replacement of the temperature limiter is identical with the heater removed or installed. Replacement is to be performed in accordance with 9.2.3.

8.7.4 Replacement of Temperature Sensor

NOTE

The procedure for replacement of the temperature sensor is identical with the heater removed or installed. Replacement is to be performed in accordance with 9.2.4.

8.7.5 Replacement of Combustion Air Fan

NOTE

The procedure for replacement of the combustion air fan is identical with the heater removed or installed. Replacement is to be performed in accordance with 9.2.5.

8.8 First Operation

After installation of the heater, the fuel supply system and the cooling circuit must be thoroughly bled observing the vehicle manufacturer's instructions. During the test run of the heater all connections are to be checked for leakage and tight fit. Should the heater during operation assume an error lock-out condition, perform troubleshooting (see Section 5).

BUTLER TECHNIK

9 Repair

9.1 General

This section describes the repairs that may be performed on the heater Thermo 90 when removed. Any further disassembly will void the warranty. For re-assembly only Webasto-authorized spare parts kits are to be used.

9.1.1 Work on Components after Disassembly

CAUTION

All gaskets located between disassembled components must always be replaced and discarded.

9.1.1.1 Cleaning

- All disassembled components must be cleaned.

9.1.1.2 Visual Inspection

- Examine all components for damages (cracks, deformation, wear, etc.) and replace as necessary.
- Examine connectors and wiring for corrosion, loose contacts, wrong crimping, etc. and repair as necessary.
- Check terminals for corrosion and contacts for security. Repair as required.

9.2 Disassembly and Assembly

9.2.1 Electrical Connections (Fig. 901)

9.2.1.1 Disconnecting Electrical Connections (Connection X1)

NOTE

All electrical connections are joined in the connector. Prior to removal of a component, the relevant electrical connections first have to be disconnected.

On heater Thermo 90 S with flanged combustion air fan connector X1 on heater and connection X12 on control unit must be disconnected and reconnected after making electrical connections.

1. Remove top cover from heater.
2. Using removal tool (hook end) withdraw lock wedge from connector.
3. Using removal tool (screw driver end) press down relevant locking tab and keeping tab depressed withdraw cables from connector.

9.2.1.2 Making Electrical Connections

1. Slide cable into relevant contact pocket until locked.
2. Using removal tool (screw driver end) insert lock wedge in connector and press in until locked.
3. Fit top cover.

NOTE

One of the newer models Thermo 90 shown. Older models have the cable of the temperature limiter located on the side. Heater Thermo 90 S may have the control unit located on the combustion air fan.

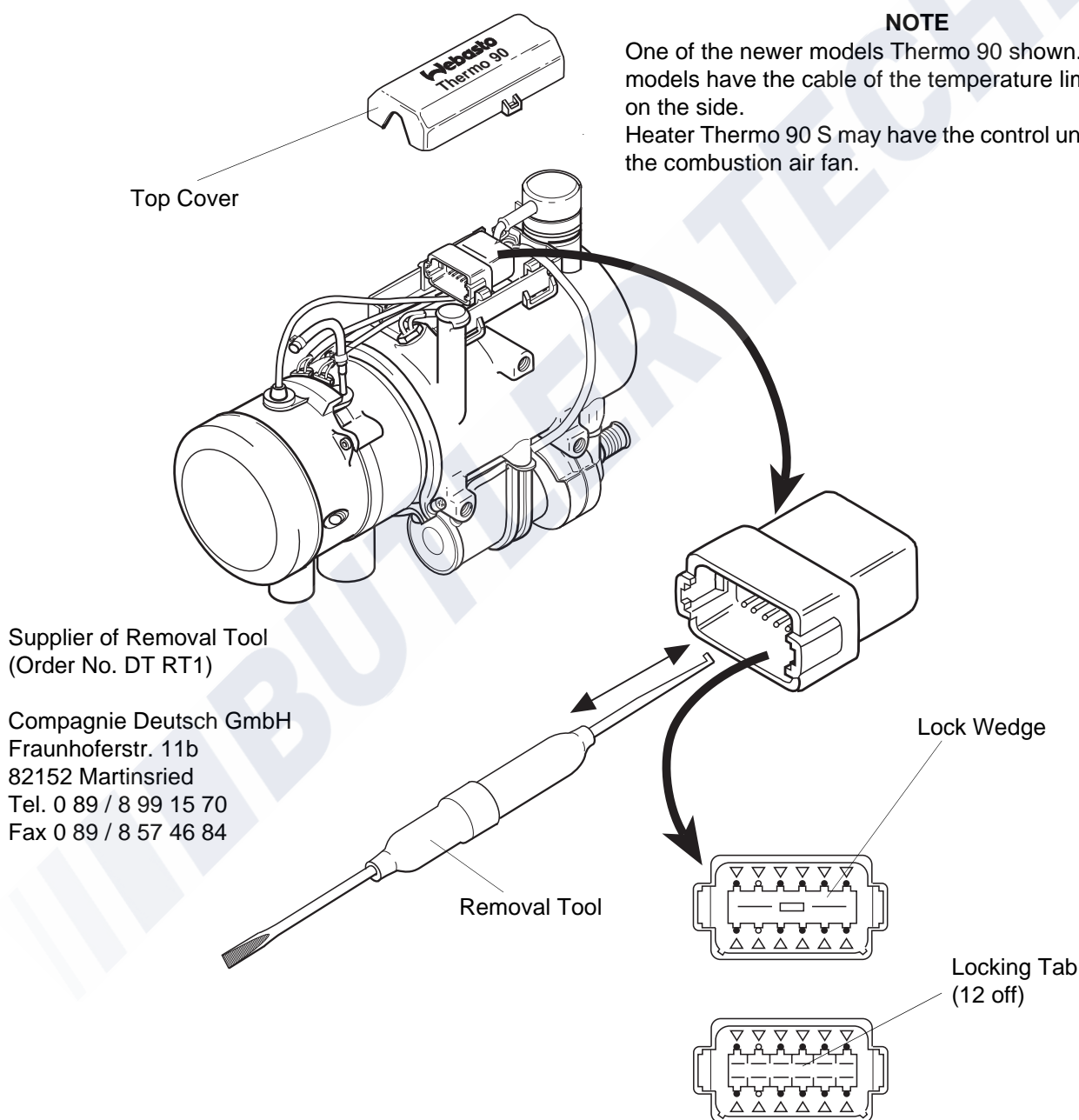

Fig. 901 Electrical Connections

9.2.2 Replacement of Circulation Pump

9.2.2.1 Removal

1. Remove heater (see 8.7.1.1).
2. Disconnect electrical connections (see 9.2.1.1).
3. Remove screws (4, Fig. 902).
4. Remove clamp (3) and circulation pump (2).
5. Perform procedures on components after disassembly (see 9.1.1).

9.2.2.2 Installation

1. Apply acid free grease (Vaseline) to gasket (1, Fig. 902)
2. Bring circulation pump (2) in assembly position and secure using clamp (3) and screws (4).
3. Torque screws (4) to 3 Nm \pm 10%.
4. Make electrical connections (see 9.2.1.2).
5. Install heater (see 8.7.1.2).

NOTE

One of the newer models Thermo 90 shown. Older models have the cable of the temperature limiter located on the side. Heater Thermo 90 S may have the control unit located on the combustion air fan not affecting the replacement of the circulation pump.

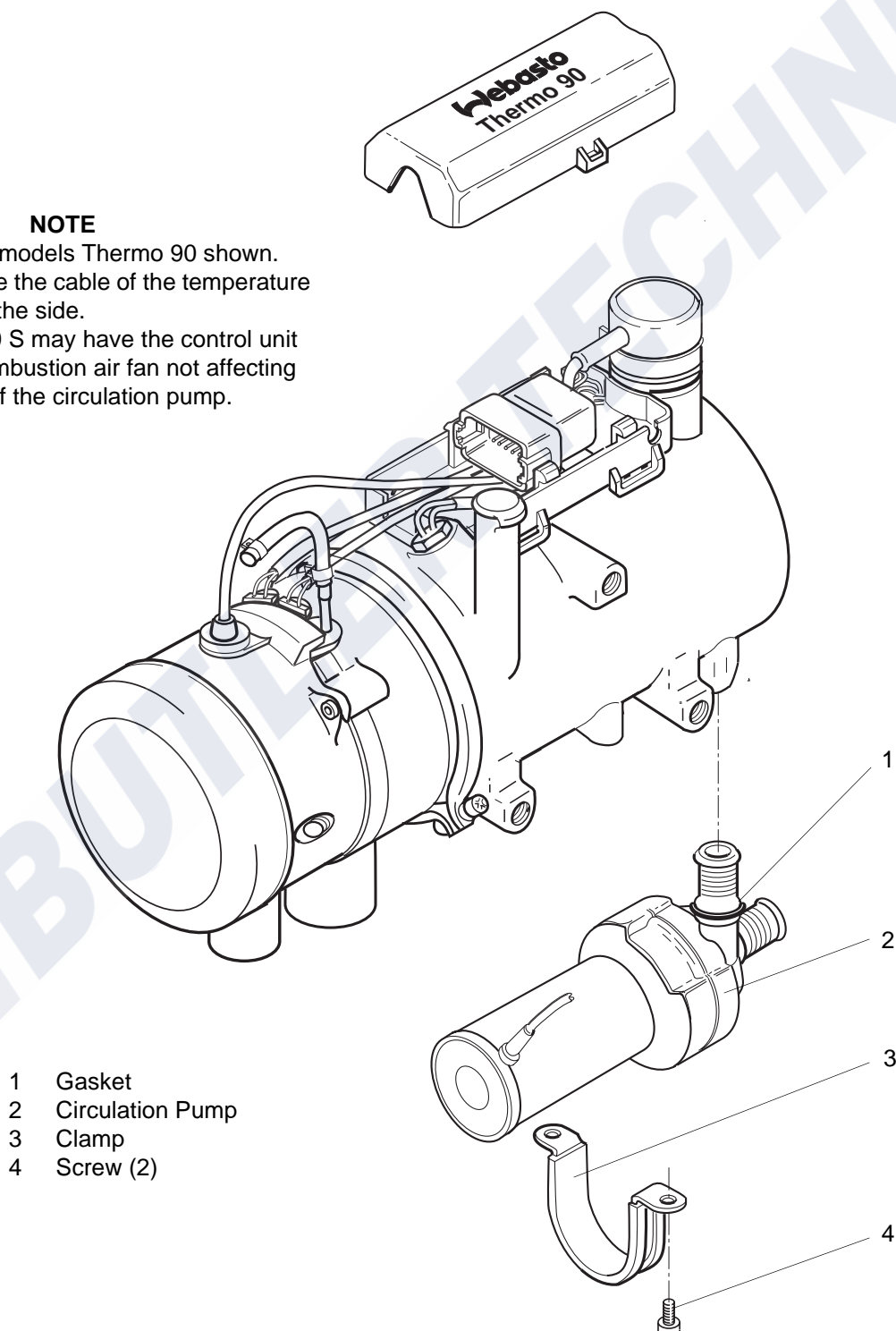

Fig. 902 Replacement of Circulation Pump

9.2.3 Replacement of Temperature Limiter

9.2.3.1 Removal

NOTE

Perform the following procedure only when the temperature limiter needs replacement.

A functional check has to be performed when the temperature limiter is installed.

1. Remove heater (see 8.7.1.1).
2. Disconnect electrical connections (see 9.2.1.1).
3. Remove clamp (2, Fig. 903) and withdraw protective cap (1).
4. Using screw driver, lever off retaining clip and remove temperature limiter (3).
5. Perform procedures on components after disassembly (see 9.1.1).

NOTE

Whenever the temperature limiter is removed, it must be renewed.

9.2.3.2 Installation

CAUTION

Wrong installation will cause melting of the heat exchanger.

1. Insert the temperature limiter (3, Fig 903) into the heat exchanger (4) and press down retaining clip.

NOTE

Make sure the retaining clip is heard to click fully in place. Only then will the temperature limiter be in proper installation position.

If clip does not audibly engage

- clean seat of the temperature limiter on the heat exchanger
 - clean groove on heat exchanger
 - ensure that the locking cams are present on both sides of the spring. Renew temperature limiter if necessary.
2. Fit protective cap (1) and secure with clamp (2).
 3. Torque tighten hose clamp with $1 \text{ Nm} \pm 10\%$.
 4. Make electrical connections (see 9.2.1.2).
 5. Install heater (see 8.7.1.2).

9.2.4 Replacement of Temperature Sensor

9.2.4.1 Removal

1. Remove heater (see 8.7.1.1).
2. Disconnect electrical connections (see 9.2.1.1).

WARNING

Escaping hot coolant may cause burns.

3. Unscrew temperature sensor (6, Fig. 903) and remove together with O-ring (5).
4. Perform procedures on components after disassembly (see 9.1.1).

9.2.4.2 Installation

1. Apply acid free grease (Vaseline) to O-ring (5, Fig. 904).
2. Screw temperature sensor (6) with O-ring (5) into heat exchanger (4) and torque tighten with $1.5 \text{ Nm} \pm 10\%$.
3. Make electrical connections (see 9.2.1.2).
4. Install heater (see 8.7.1.2).

NOTE

One of the newer models Thermo 90 shown. Older models have the cable of the temperature limiter located on the side. Heater Thermo 90 S may have the control unit located on the combustion air fan not affecting the replacement of the temperature limiter and temperature sensor.

- 1 Protective Cap
- 2 Clamp
- 3 Temperature Limiter
- 4 Heat Exchanger
- 5 O-Ring
- 6 Temperature Sensor

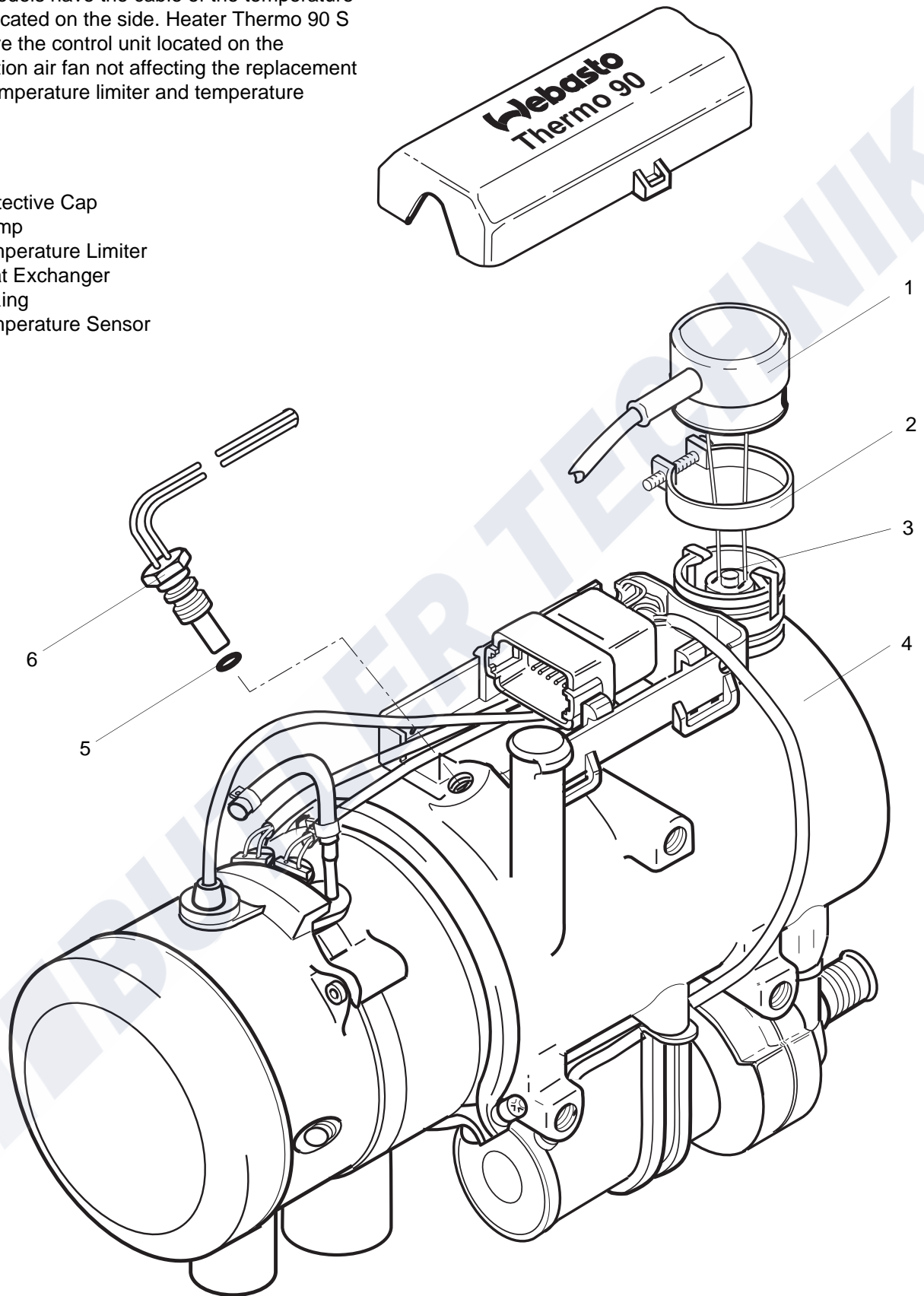

Fig. 903 Replacement of Temperature Limiter and Temperature Sensor

9.2.5 Replacement of Combustion Air Fan

9.2.5.1 Removal

1. Remove heater (see 8.7.1.1).
2. Disconnect electrical connections (see 9.2.1.1).
3. Remove screws (2, Fig. 904).
4. Pull combustion air fan (1) from burner head (4) and remove together with profiled packing ring (3).

NOTE

On heater Thermo 90 S with flanged control unit remove control unit as required.

5. Perform procedures on components after disassembly (see 9.1.1).

9.2.5.2 Installation

NOTE

Locate packing ring (3, Fig. 904) properly; do not squeeze.

1. Bring combustion air fan (1) with new profiled packing ring (3) in assembly position and secure with screws (2).
2. Torque tighten screws (2) with $3 \text{ Nm} \pm 10\%$.

NOTE

On heater Thermo 90 S with flanged control unit install control unit as required.

3. Make electrical connections (see 9.2.1.2).
4. Install heater (see 8.7.1.2).

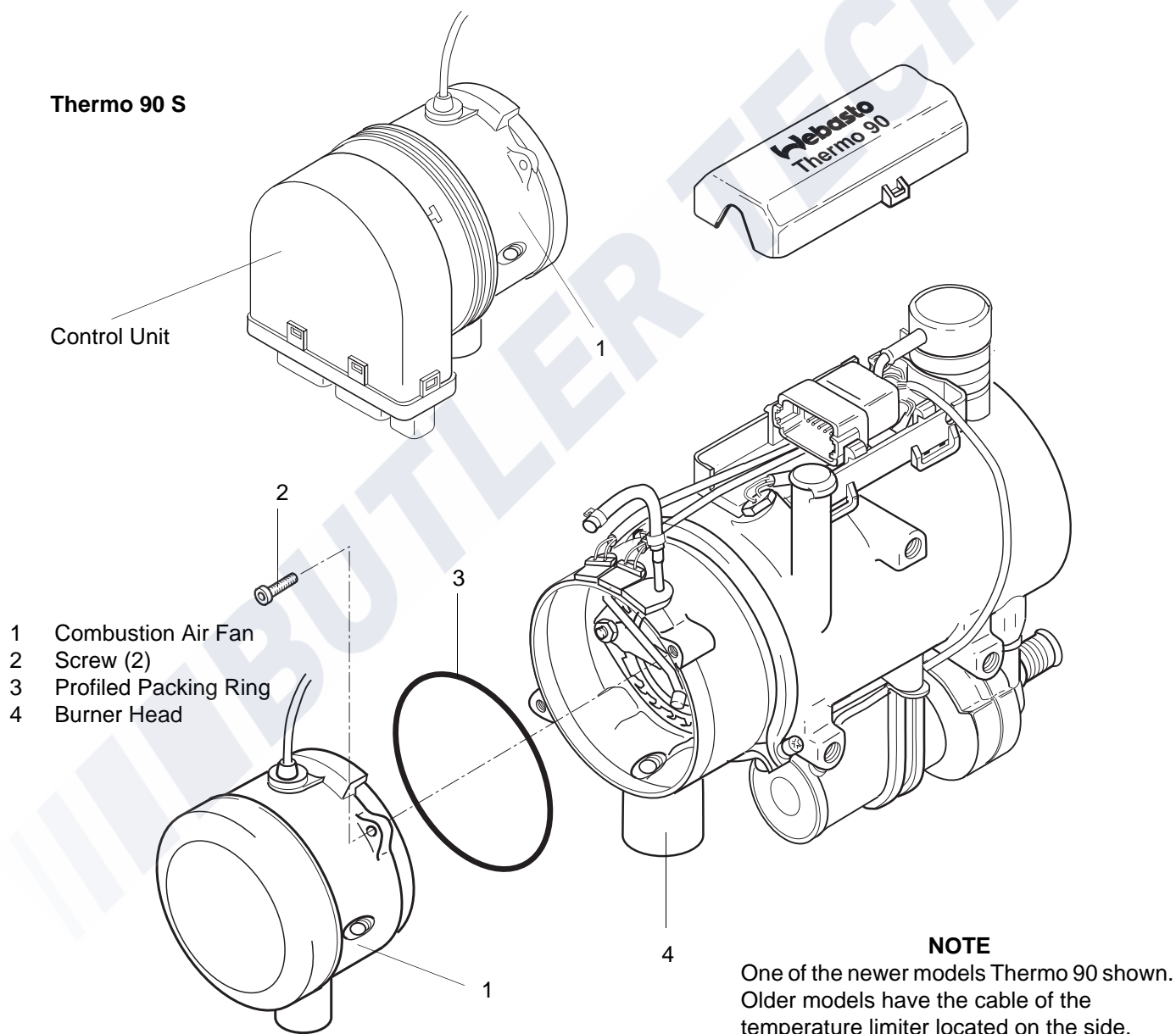

Fig. 904 Replacement of Combustion Air Fan

9.2.6 Replacement of Burner, Flame Sensor, and Glow Plug

9.2.6.1 Removal

1. Remove heater (see 8.7.1.1).
2. Remove combustion air fan (see 9.2.5.1).
3. Remove screw (5, Fig. 905) and washer (4).
4. Remove nuts (10) and withdraw bracket.
5. Withdraw grommets (11 and 12) from slots in housing of combustion tube (3).
6. Withdraw grommet (13) and burner (1) from burner head and remove together with swirl ring (2).
7. Pull flame sensor (7) and glow plug (6) out of burner (1) and remove.
8. Perform burner visual inspection for assessment of condition (see 5.3).
9. Perform procedures on components after disassembly (see 9.1.1).

9.2.6.2 Installation

1. Locate swirl ring (2, Fig. 905) on burner (1).
2. Carefully and fully insert flame sensor (7) and glow plug (6) into burner against stop and slide grommets (11 and 12) down slots in housing of combustion tube (3).
3. Position burner (1) and grommet (13) in burner head (3).

CAUTION

When performing the following step ensure that cables of flame sensor (7) and glow plug (6) are routed as shown in figure.

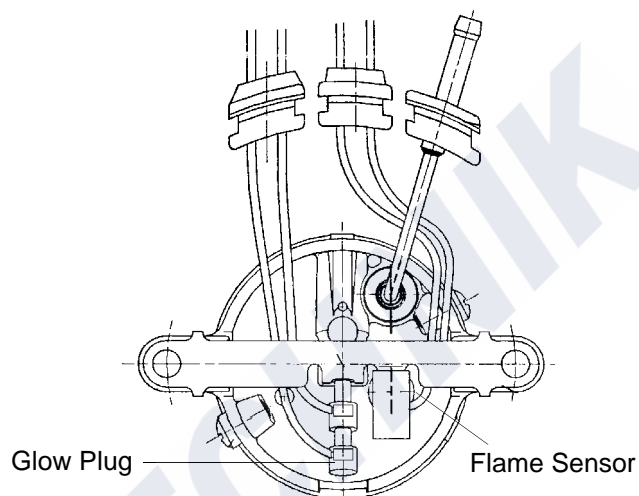

4. Slide insulation (9) onto bracket and locate bracket (8) in assembly position.

NOTE

Route cables of flame sensor and glow plug as shown in Figure!

5. Secure bracket (8) using nuts (10). Torque nuts to $3 \text{ Nm} \pm 10\%$.
6. Secure fuel line with screw (5) and washer (4). Torque screw to $3 \text{ Nm} \pm 10\%$.
7. Mount combustion air fan (see 9.2.4.2).
8. Make electrical connections (see 9.2.1.2).
9. Install heater (see 8.7.1.2).

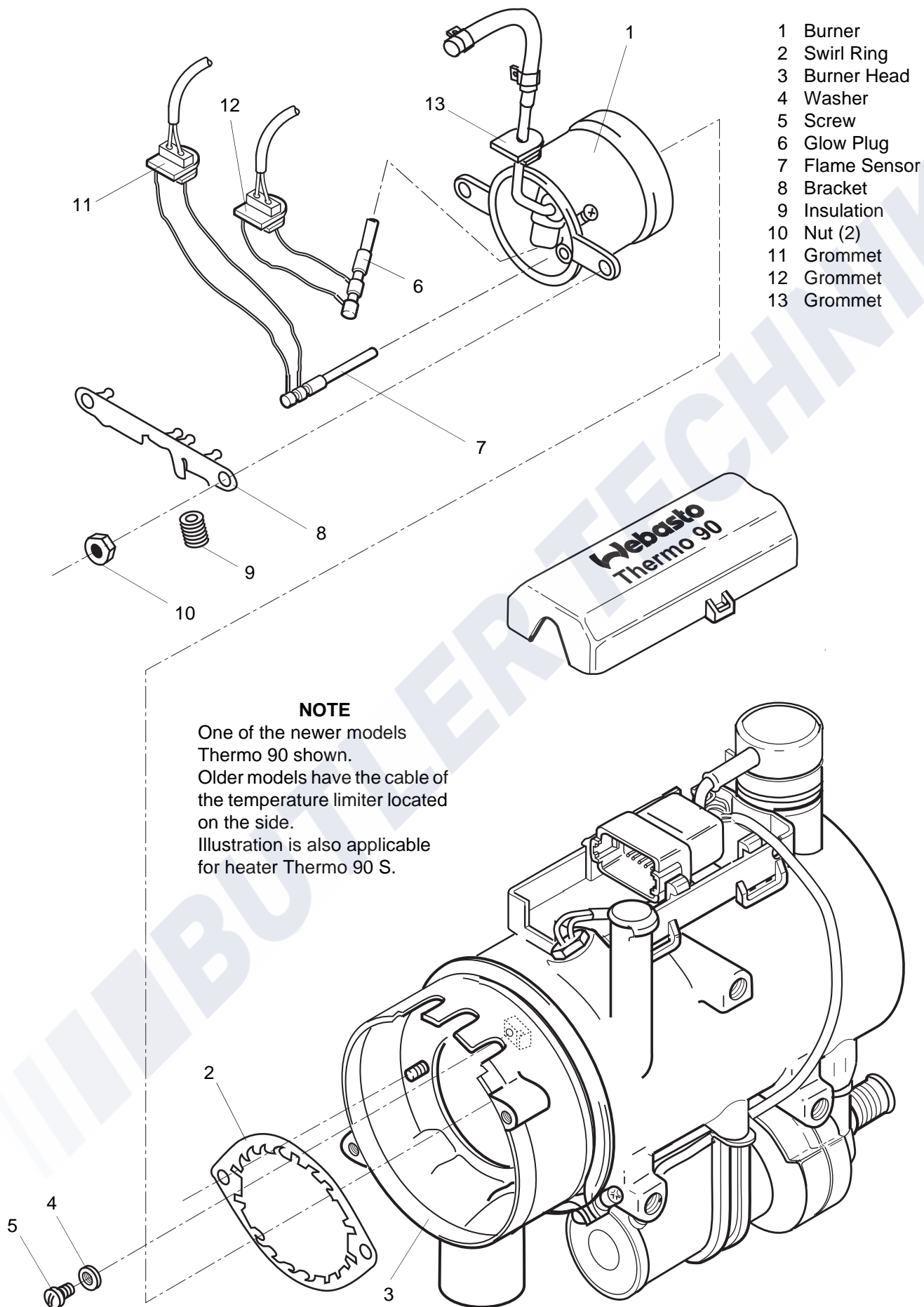

Fig. 905 Replacement of Burner, Flame Sensor, and Glow Plug

9.2.7 Replacement of Burner Head

9.2.7.1 Removal

1. Remove heater (see 8.7.1.1).
2. Remove combustion air fan (see 9.2.5.1).
3. Remove burner, flame sensor, and glow plug (see 9.2.6.1).
4. Remove attachment screw of V-clamp (2, Fig. 906) and pull off clamp.
5. Withdraw burner head (1) from heat exchanger (3) and remove.
6. Perform procedures on components after disassembly (see 9.1.1).

9.2.7.2 Installation

NOTE

Burner head and exhaust outlet pipe can still be aligned during installation in vehicle.

1. Insert burner head (1, Fig. 906) into heat exchanger (3), align as necessary and secure with V-clamp (2).
2. Torque attachment screw of V-clamp to $3 \text{ Nm} \pm 10\%$ as required.
3. Install burner, flame sensor, and glow plug (see 9.2.6.2).
4. Install combustion air fan (see 9.2.5.2).
5. Install heater (see 8.7.1.2).

NOTE

One of the newer models Thermo 90 shown. Older models have the cable of the temperature limiter located on the side.

Illustration is also applicable for heater Thermo 90 S.

- 1 Burner Head
- 2 V-Clamp
- 3 Heat Exchanger

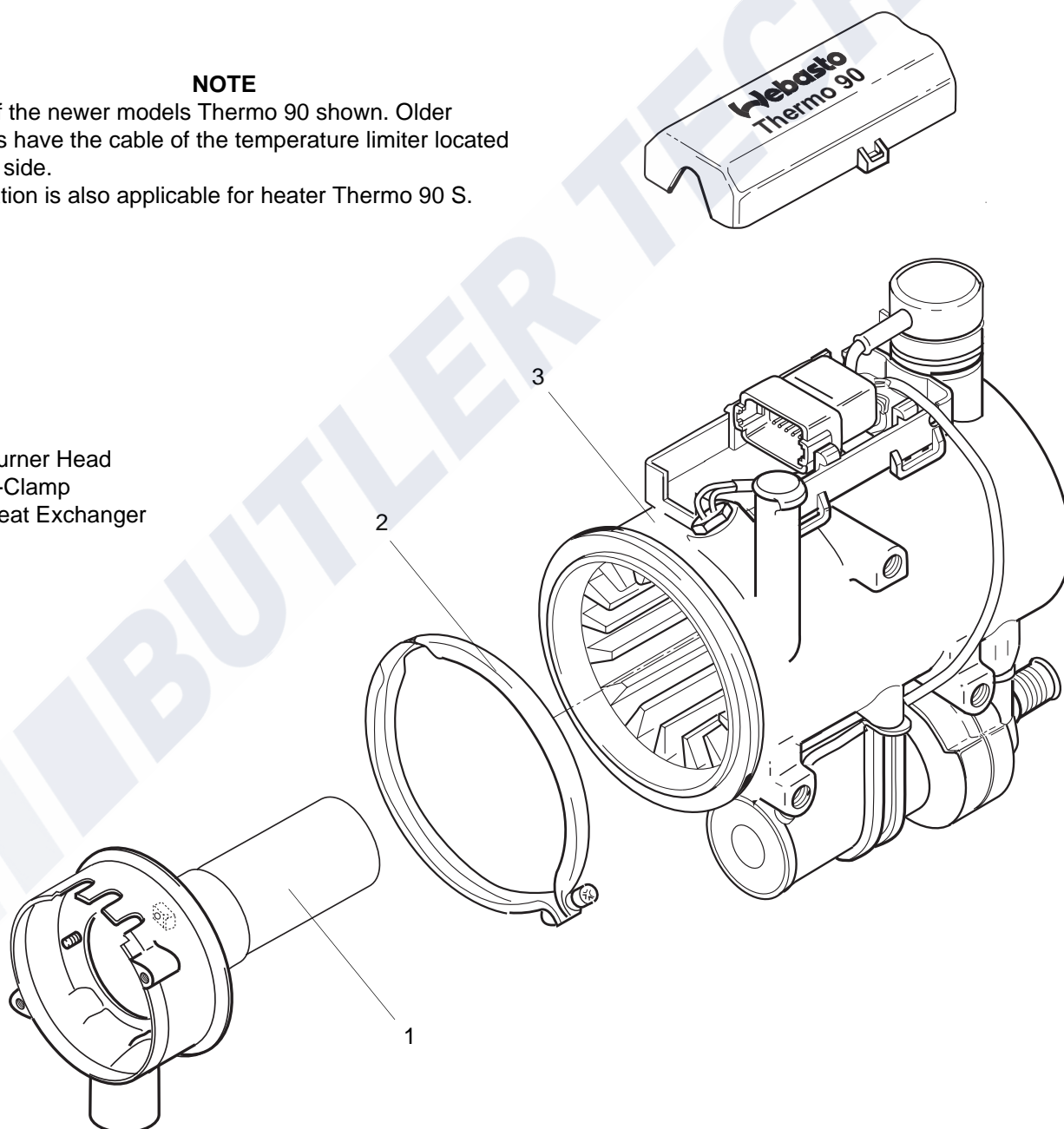

Fig. 906 Replacement of Burner Head

9.2.8 Replacement of Heat Exchanger

9.2.8.1 Removal

1. Remove heater (see 8.7.1.1).
2. Remove circulation pump (see 9.2.2.1).
3. Remove temperature limiter (see 9.2.3.1).
4. Remove temperature sensor (see 9.2.4.1).
5. Remove combustion air fan (see 9.2.5.1).
6. Remove burner, flame sensor, and glow plug (see 9.2.6.1).
7. Remove burner head (see 9.2.7.1).
8. Remove connector and connector housing.
9. Perform procedures on components after disassembly (see 9.1.1).

9.2.8.2 Installation

1. Clip connector housing onto heat exchanger and engage connector in connector housing.
2. Install burner head (see 9.2.7.2).
3. Install burner, flame sensor, and glow plug (see 9.2.6.2).
4. Install combustion air fan (see 9.2.5.2).
5. Install temperature sensor (see 9.2.4.2).
6. Install temperature limiter (see 9.2.3.2).
7. Install circulation pump (see 9.2.2.2).
8. Install heater (see 8.7.1.2).

10 Packaging/Storage and Shipping

10.1 General

The heater and its components shipped to Webasto Thermosysteme GmbH for inspection or repair are to be cleaned and packaged so that they are protected against damage during handling, transportation, and storage.

CAUTION

Should a complete heater assembly be shipped it must be totally emptied. When packaging or shipping it must be ensured that no fuel or coolant is able to escape.

The coolant pipe joints are to be sealed with plugs.

In storage, ambient temperatures detailed in Section 4 must not be exceeded.

BUTLER TECHNIK