

Air heaters

Workshop Manual

Air Top Evo 3900

Type Air Top Evo 3900/5500 B
(Petrol)

Type Air Top Evo 3900/5500 D
(Diesel/PME)



Improper installation or repair of Webasto heating and cooling systems can cause fire or the leakage of deadly carbon monoxide leading to serious injury or death.



To install and repair Webasto heating and cooling systems you need to have completed a Webasto training course and have the appropriate technical documentation, special tools and special equipment.

Only genuine Webasto parts may be used. See also Webasto air and water heaters accessories catalogue.

NEVER try to install or repair Webasto heating or cooling systems if you have not completed a Webasto training course, you do not have the necessary technical skills and you do not have the technical documentation, tools and equipment available to ensure that you can complete the installation and repair work properly.

ALWAYS carefully follow Webasto installation and repair instructions and heed all WARNINGS.

Webasto rejects any liability for problems and damage caused by the system being installed by untrained personnel.

BUTLER TECHNIK

Table of Contents

1	Introduction	101
1.1	Contents and purpose	101
1.1.1	Use of the air heaters	101
1.2	Meaning of signal words	101
1.3	Additional documentation to be used	101
1.4	Statutory regulations and safety instructions	101
1.4.1	Statutory regulations governing installation	101
1.4.2	General safety information	103
2	General description	201
2.1	Drive unit	201
2.2	Heat exchanger	202
2.3	Burner insert with combustion chamber	202
2.4	Control unit	202
2.5	Glow plug / Flame monitor	203
2.6	Overheating sensor	203
2.7	Metering pump	203
3	Function Description	301
3.1	Control element	301
3.2	Operating modes of heater	301
3.2.1	Comfort heating	301
3.2.2	Eco mode	301
3.2.3	Plus mode	301
3.2.4	Altitude compensation	301
3.2.5	Ventilation	301
3.3	Switching on	301
3.4	Heating mode	302
3.5	Control mode	302
3.6	Control pause	302
3.7	Switching off	302
3.8	Functions of Air Top Evo AM System	302
3.8.1	System design	302
3.8.2	Initial Installation/Initial Operation	303
3.8.3	Resetting Master/Slave System	303
3.9	Heater functions when installed in ADR vehicles	303
3.9.1	Extract of the directives 2001/56/EG Annex IX and ECE R122 Annex 9	303
3.10	Fault lock-out	304
3.10.1	Error monitoring	304
3.10.2	Reset a fault lock-out	305
4	Technical data	401
5	Troubleshooting	501
5.1	General	501
5.2	General error symptoms	501
5.3	Error symptoms during function	502
5.4	Error code output	503

6	Function Tests	601
6.1	General	601
6.2	Required test and measuring equipment	601
6.3	Settings	602
6.3.1	Setting CO2 content	602
6.3.2	CO2 setting of reference heater	603
6.4	Testing individual components	603
6.4.1	Burner component	604
6.4.2	Combustion and hot air fan component	605
6.4.3	Glow plug component	605
6.4.4	Drive component	607
6.4.5	Overheating sensor component	608
6.4.6	Control unit component	609
6.4.7	Heater component	610
7	Circuit diagrams	701
7.1	General	701
7.2	Legend for circuit diagrams	707
8	Servicing work	801
8.1	General	801
8.2	Work on the heater	801
8.3	Work on the vehicle	801
8.4	Heater trial	801
8.5	Servicing work	801
8.6	Visual inspections and installation instructions	801
8.6.1	Hot air system	801
8.6.2	Fuel supply	802
8.6.3	Metering pump	804
8.6.4	Fuel filter	805
8.6.5	Combustion air supply	805
8.6.6	Exhaust pipe	805
8.6.7	Combustion air inlet and exhaust lines	805
8.6.8	Electrical connections	806
8.7	Removal and installation	809
8.7.1	Heater, removal and installation	809
8.8	Start-up	809

9	Repair	901
9.1	General.....	901
9.1.1	Work on stripped down components	901
9.1.2	Carrying out modifications	901
9.2	Dismantling and assembling	902
9.2.1	Remove the casing parts	902
9.2.2	Fit the casing parts	902
9.2.3	Change the control unit	904
9.2.4	Change the overheating sensor	904
9.2.5	Change combustion and hot air fan (drive unit)	904
9.2.6	Change burner and glow plug/flame sensor	906
9.2.7	Change the combustion chamber and the heat exchanger	906
10	Packaging, storage and shipping	1001
10.1	General.....	1001

List of Illustrations

Fig. 201	Air Top Evo 3900/5500 air heater.	201
Fig. 202	Air Top Evo 3900/5500 air heater without casing.	201
Fig. 203	Drive unit.	201
Fig. 204	Heat exchanger	202
Fig. 205	Burner insert (diesel) and combustion chamber.	202
Fig. 206	Burner insert (petrol) and combustion chamber	202
Fig. 207	Control unit.	202
Fig. 208	Glow plug / Flame monitor.	203
Fig. 209	Overheating sensor	203
Fig. 210	Metering pump DP2 / DP 30.2.	203
Fig. 401	Technical data of Air Top Evo 3900/5500	401
Fig. 402	Setpoint values for resistance values of components.	402
Fig. 501	General error symptoms.	501
Fig. 502	Error symptoms during function.	502
Fig. 503	Troubleshooting (Page 1 of 2)	503
Fig. 503	Troubleshooting (Page 2 of 2)	504
Fig. 601	Characteristic resistance values of a PT 2000 overheating system in a temperature range of 10 °C to 30 °C.	608
Fig. 701	Plug assignment.	701
Fig. 702	System circuit diagram 12V/24V with control element and vehicle blower	702
Fig. 703	System circuit diagram 24V ADR operation with control element	702
Fig. 704	System circuit diagram 12V/24V with combination timer and vehicle blower	703
Fig. 705	System circuit diagram (diesel) 12V/24V with combination timer and electrical battery isolation switch.	703
Fig. 706	System circuit diagram (diesel) 12V/24V with Control Panel MC04/05 and vehicle blower	704
Fig. 707	System wiring diagram Air Top Evo 3900 / 5500 AM "Master heater unit", 12V/24V Diesel with controls	704
Fig. 708	System wiring diagram Air Top Evo 3900 / 5500 AM "Slave heater unit", 12V/24V Diesel	705
Fig. 709	Schematic connection of the combination timer.	705
Fig. 710	Schematic connection of the Control Panel MC04/05.	706
Fig. 711	Connection diagram of Air Top Evo 3900/5500 AM (connection of combination timer 1531 and setpoint generator possible).	706
Fig. 801	Fuel supply.	802
Fig. 802	Webasto tank connector	803
Fig. 803	Fuel extractor from the plastic tank (extraction through tank drain screw)	803
Fig. 804	Fuel extractor from the plastic tank (extraction through tank fitting).	803
Fig. 805	Pipe/Hose connections	804
Fig. 806	Metering pump, installation position	804
Fig. 807	Fuel filter	805
Fig. 808	Exhaust silencer	805
Fig. 809	Exhaust pipe ends, installation position.	806
Fig. 810	Remove the fastening plate on the fuse holder.	806
Fig. 811	Fuse holder, installation position.	806
Fig. 812	Control element.	807
Fig. 813	Disconnect the plug	807
Fig. 814	Installation example for heater in recirculation mode	808
Fig. 901	External temperature sensor.	901
Fig. 902	Remove/fit the casing parts	903
Fig. 903	Change control unit, overheating sensor and combustion and hot air fan (drive unit)	905
Fig. 904	Change burner, glow plug/flame sensor, combustion chamber and heat exchanger	907

1 Introduction

1.1 Contents and purpose

This workshop manual is designed to assist trained personnel, with repairing both the petrol and the diesel versions of the Air Top Evo 3900/5500 air heaters.

1.1.1 Use of the air heaters

The Webasto Air Top Evo 3900 and Air Top Evo 5500 air heaters are designed

- to heat cabins, boats, trucks, minibuses, vans, ambulances and motorhomes
- to defrost vehicle windows
- to heat cargo

They are not designed for heating cargo areas used to carry hazardous substances.

The heaters operate independently of the engine and are connected directly to the fuel tank and the electrical system of the vehicle.

They may be used for vehicles with either water or air-cooled engines.

1.2 Meaning of signal words

Throughout this manual, the signal words WARNING, IMPORTANT and NOTE have the following meanings:

WARNING

This heading is used to highlight operating instructions or procedures which, if not or not correctly followed, may result in personal injury or fatal accidents.

IMPORTANT

This heading is used to highlight operating instructions or procedures which, if not or not correctly followed, may result in damage to the equipment or its components.

NOTE

This heading is used to direct your attention to a special feature deemed essential to highlight.

1.3 Additional documentation to be used

This workshop manual contains all the information and instructions required for repairing the Air Top Evo 3900 and Air Top Evo 5500 air heaters.

Normally, there is no need to use additional documentation. If necessary the operating / installation instructions and the installation suggestion for the specific vehicle may also be used.

1.4 Statutory regulations and safety instructions

In principle, the general accident prevention regulations and current works safety instructions are applicable.

The "General safety regulations" that go beyond the scope of the above regulations are stated below.

Any special safety regulations relevant to this instruction manual will be highlighted in the relevant sections or text passages of the procedures.

1.4.1 Statutory regulations governing installation

The Air Top Evo 3900 and Air Top Evo 5500 heaters have been type-tested and approved in accordance with Directives ECE R10 and EC 72/245/EEC (EMC) and ECE R122 and 2001/56/EC (heater) with the following EC permit numbers:

EMC: e1*72/245*2006/96*5529*__
(Air Top Evo 3900 / 5500)
E1 03 5529 (Air Top Evo 3900 / 5500)

Heater: e1*2001/56*2006/119*0255*__
(Air Top Evo 3900)
E1 00 0255 (Air Top Evo 3900)
e1*2001/56*2006/119*0256*__
(Air Top Evo 5500)
E1 00 0256 (Air Top Evo 5500)

Primarily the regulations of Annex VII of the Directive 2001/56/EC and Part I and Annex 7 of the directive ECE R122 must be observed for the installation.

NOTE

The specifications of this Directive are binding in the scope of the Basic Directive EEC/70/156 and/or EC/2007/46 (for new vehicle models from 29/04/2009) and should also be observed in countries in which no special regulations exist.

Extract from the directives 2001/56/EC Annex VII and ECE R122 Part I and Annex 7

Start of extract.

ANNEX VII

REQUIREMENTS FOR COMBUSTION HEATERS AND THEIR INSTALLATION

1. GENERAL REQUIREMENTS

1.7.1. / 7.1. (Annex 7) A clearly visible tell-tale in the operator's field of view shall inform when the combustion heater is switched on or off.

2. / 5.3. (Part I) VEHICLE INSTALLATION REQUIREMENTS

2.1. / 5.3.1. (Part I) Scope

2.1.1. / 5.3.1.1. (Part I) Subject to paragraph 2.1.2. / 5.3.1.2. (Part I) combustion heaters shall be installed according to the requirements of this Annex.

2.1.2. / 5.3.1.2. (Part I) Vehicles of category O having liquid fuel heaters are deemed to comply with the requirements of this Annex.

2.2. / 5.3.2. (Part I) Positioning of heater

2.2.1. / 5.3.2.1. (Part I) Body sections and any other components in the vicinity of the heater must be protected from excessive heat and the possibility of fuel or oil contamination.

2.2.2. / 5.3.2.2. (Part I) The combustion heater shall not constitute a risk of fire, even in the case of overheating. This requirement shall be deemed to be fulfilled if the installation ensures an adequate distance to all parts and suitable ventilation, by the use of fire resistant materials or by the use of heat shields.

2.2.3. / 5.3.2.3. (Part I) In the case of M2 and M3 vehicles, the heater must not be positioned in the passenger compartment. However, an installation in an effectively sealed envelope which also complies with the conditions in paragraph 2.2.2. / 5.3.2.2. (Part I) may be used.

2.2.4. / 5.3.2.4. (Part I) The label referred to in paragraph 1.4 / Annex 7 paragraph 1.4. or a duplicate, must be positioned so that it can be easily read when the heater is installed in the vehicle.

2.2.5. / 5.3.2.5. (Part I) Every reasonable precaution should be taken in positioning the heater to minimise the risk of injury and damage to personal property.

2.3. / 5.3.3. (Part I) Fuel supply

2.3.1. / 5.3.3.1. (Part I) The fuel filler must not be situated in the passenger compartment and must be provided with an effective cap to prevent fuel spillage.

2.3.2. / 5.3.3.2. (Part I) In the case of liquid fuel heaters, where a supply separate to that of the vehicle is provided, the type of fuel and its filler point must be clearly labelled.

2.3.3. / 5.3.3.3. (Part I) A notice, indicating that the heater must be shut down before refuelling, must be affixed to the fuelling point. In addition a suitable instruction must be included in the manufacturer's operating manual.

2.4. / 5.3.4. (Part I) Exhaust system

2.4.1. / 5.3.4.1. (Part I) The exhaust outlet must be located so as to prevent emissions from entering the vehicle through ventilators, heated air inlets or opening windows.

2.5. / 5.3.5. (Part I) Combustion air inlet

2.5.1. / 5.3.5.1. (Part I) The air for the combustion chamber of the heater must not be drawn from the passenger compartment of the vehicle.

2.5.2. / 5.3.5.2. (Part I) The air inlet must be so positioned or guarded that blocking by rubbish or luggage is unlikely.

2.6. / 5.3.6. (Part I) Heating air inlet

2.6.1. / 5.3.6.1. (Part I) The heating air supply may be fresh or recirculated air and must be drawn from a clean area not likely to be contaminated by exhaust fumes emitted either by the propulsion engine, the combustion heater or any other vehicle source.

2.6.2. / 5.3.6.2. (Part I) The inlet duct must be protected by mesh or other suitable means.

2.7. / 5.3.7. (Part I) Heating air outlet

2.7.1. / 5.3.7.1. (Part I) Any ducting used to route the hot air through the vehicle must be so positioned or protected that no injury or damage could be caused if it were to be touched.

2.7.2. / 5.3.7.2. (Part I) The air outlet must be so positioned or guarded that blocking by rubbish or luggage is unlikely.

2.8. / 5.3.8. (Part I) Automatic control of the heating system

2.8. / 5.3.8.1. (Part I) The heating system must be switched off automatically and the supply of fuel must be stopped within five seconds when the vehicle's engine stops running. If a manual device is already activated, the heating system can stay in operation.

End of extract.

1.4.2 General safety information

The mouth of the exhaust pipe should be installed upwards, to the side or, if the exhaust pipe passes under the floor of the vehicle, to the side or rear limit of the driver's cab or the vehicle.

The function of important parts of the vehicle must not be adversely affected. It must not be possible for condensate or water to collect in the exhaust pipe. Drain holes may be used.

The electric cables and controls for the air-conditioning system must be arranged in the vehicle so that their proper functioning cannot be adversely affected in normal operating conditions.

Compliance with §§ 45 and 46 of the Road Vehicle Licensing Act must be ensured for the installation of fuel lines and the installation of additional fuel tanks.

The main points from this law:

- Fuel pipes must be designed in such a way that torsion in the vehicle, movements by the engine and the like do not have a negative effect on their durability. They must be protected from mechanical damage.
- Parts that carry fuel must be protected from heat that will adversely affect their function and positioned so that dripping or evaporating fuel cannot collect or ignite on hot parts or on electrical equipment.

The air heater's heat exchanger can be used for a maximum of 10 years and must then be replaced by the manufacturer or one of its authorised workshops using a genuine spare part. A label must then be affixed to the heater showing the date of sale and the wording "Genuine spare part".

When you change the heat exchanger it is essential that you also replace the overheating protection element (temperature sensor) to prevent possible function faults caused by using the old temperature sensor.

The Air Top Evo 3900 and Air Top Evo 5500 air heaters are prepared for interior installation and sealing direct on the cabin floor or a cabin wall. Non-release connections must be used in the interior for combustion air and exhaust pipes with the accessories available from Webasto.

The seal between the heater mounting and the vehicle floor must always be installed, otherwise harmful emissions may get into the interior of the vehicle.

The hot and combustion air intake openings must be positioned in such a way that no water can ingress into them if the vehicle drives through a water hazard for which it has been approved.

The heater must not be installed in the driver's or passenger cabin of buses (vehicle classes M₂ and M₃). If the heater is nevertheless installed in such a place, the installation box must be tightly sealed against the vehicle interior. The installation box must have sufficient external ventilation to ensure that a maximum temperature of 40 °C is not exceeded in the box. Fault faults may occur if the temperature exceeds this level.

The heater must be switched off at filling stations and tank farms as a result of the risk of explosion.

Wherever inflammable vapours or dust may form (for example in the vicinity of fuel, carbon, wood dust or cereal stores or the like), the heater must be switched off as a result of the risk of explosion.

The heater must not be operated in enclosed areas such as garages and workshops without an emissions extraction system, even if you use the timer, because of the risk of asphyxiation and poisoning.

In the event of lengthy heavy smoke development, unusual combustion noise or a smell of fuel, the heater must be put out of action by removing the fuse and must not be started again until it has been examined by Webasto-trained personnel. Claims can only be made if it can be verified that the claimant has complied with the servicing and safety instructions.

Installation regulations for Webasto fuel tanks for supplying fuel to heaters in vehicles:

- The tank must not be installed in the passenger or driver's cabin of buses.
- The fuel filler neck must not be inside the passenger or driver's cabin in any vehicle.
- Fuel tanks for normal and super grades of petrol must not be immediately behind the front trim of the vehicle. They must be separated from the engine in such a way that in the event of an accident the fuel will not be expected to ignite. This does not apply to tractor units with an open driver's seat.

The fuel lines (Mecanyl hose) must not be immediately next to the exhaust pipe and must be thermally insulated if necessary, otherwise they will pose a fire risk.

All pipes that come into contact with fuel must have sealed connections, they must not be damaged in any way and the must be checked at regular intervals (at least the same intervals as an inspection of the vehicle as a whole).

NOTE

If any damage or leaks are found on the fuel line, the heater must not be used until the damage has been rectified by an authorised Webasto workshop.

Put the heater out of action by removing the fuse.

Overheating

Keep the hot air inlet and hot air outlet free of dirt and foreign bodies. Dirty, blocked air lines can cause the heater to shut down due to overheating.

After an overheating lock-out, check that the air system is clear, remove any materials that may block the air current and have any damage to the air lines repaired by an authorised Webasto workshop. After this the heater lockout can be cancelled by switching it off and then on again. If this action does not produce the required success (if the heater overheats again) take it to a Webasto-authorised workshop.

The air outlet jets or air vents with adjustable flaps must always be opened to some extent so that the air current through the heater is not completely blocked. At least one air vent must be non-closable.

If the heater is installed in a storage area, you must ensure that no inflammable substances are kept in this area and that other material does not restrict the air supply to the heater.

Air lines must be securely fixed to the heater (using pipe clips, for example) and all other connection points (for example vents).

IMPORTANT

The errors described below are to be avoided at all costs:

- Do not stand on the heater and do not place any heavy items on the heater or throw items at the heater.
- Do not place any items of clothing, textiles or similar materials over the heater or in front of the hot air inlet and the hot air outlet.
- The current of hot air in the heater must not be restricted or blocked by highly inflammable substances or materials such as rags, cleaning wool, etc.
- Inflammable or explosive substances and gases must not be placed near or in contact with the heater, the hot air line, the current of hot air or the exhaust pipe.
- The heater must not be cleaned with a high pressure cleaner.
- Do not switch the heater off at the main battery switch or battery isolation switch since otherwise it is possible that it may suffer long term damage if it is switched off frequently using the battery isolation switch and this can cause damage and negative influences on the function of the heater.

NOTE

Failure to follow the installation instructions and the notes contained therein will lead to all liability being refused by Webasto. The same applies if repairs are carried out incorrectly or with the use of parts other than genuine spare parts. This will result in the invalidation of the type approval for the heater and therefore of its homologation / EC type licence.

You must read the operating manual before starting the heater for the first time.

2 General description

The Air Top Evo 3900 and Air Top Evo 5500 air heaters are based on the evaporator principle and essentially consist of the following

- The drive unit with a combustion and hot air blower
- The heat exchanger
- The burner insert with combustion chamber
- The control unit

To control and monitor it, the heater has the following components inside it:

- a control unit with temperature sensor
- a glow plug / flame monitor
- an overheating sensor

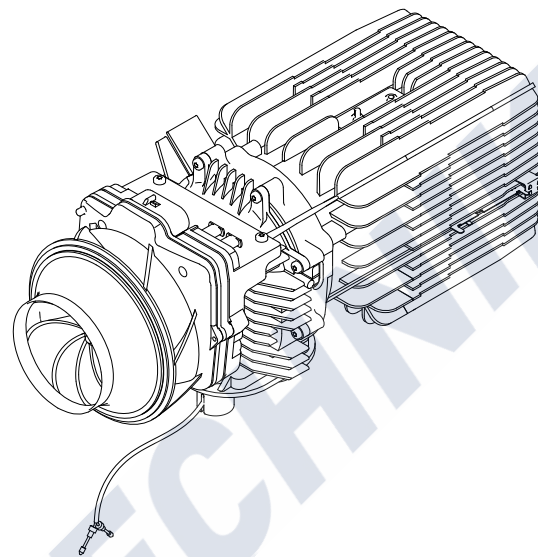

Fig. 202 Air Top Evo 3900/5500 air heater without casing

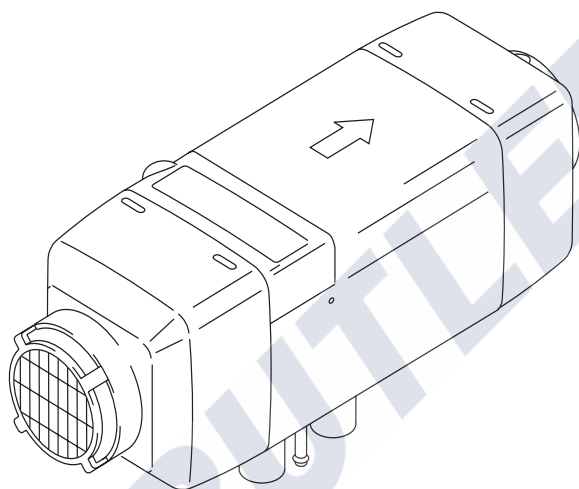

Fig. 201 Air Top Evo 3900/5500 air heater

The fuel supply is provided from an external source using a metering pump.

If a fault occurs, an error code will be output in the display of the combination or standard timer. If the heater has a control element, the ON control light will flash. In addition the heater can be checked using a personal computer (see PC heater diagnostic operating manual).

The heater may be controlled using an external temperature sensor instead of the internal temperature sensor.

2.1 Drive unit

The drive unit consists of the drive motor, the combustion air blower, the heat air blower and the intake casing. The combustion air blower supplies the air required for the combustion process from the combustion air inlet to the burner insert.

The hot air blower transports the hot air from the hot air inlet via the heat exchanger to the hot air outlet.

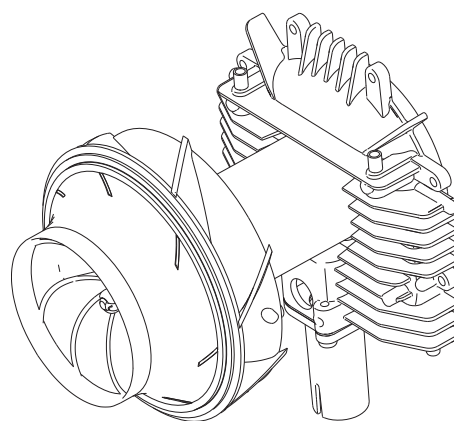

Fig. 203 Drive unit

2.2 Heat exchanger

The heat generated by the combustion process is transferred to the air transported by the combustion and hot air blowers in the heat exchanger.

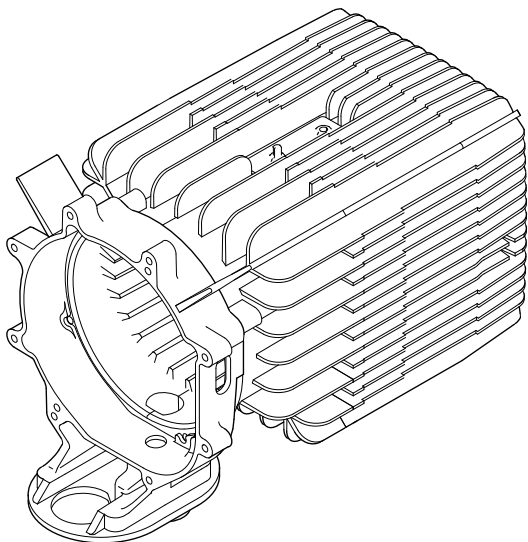

Fig. 204 Heat exchanger

2.3 Burner insert with combustion chamber

The fuel is distributed over the burner cross-section in the combustion chamber in the burner insert. The mixture of fuel and air burns in the combustion chamber, thus causing the heat exchanger to become hot.

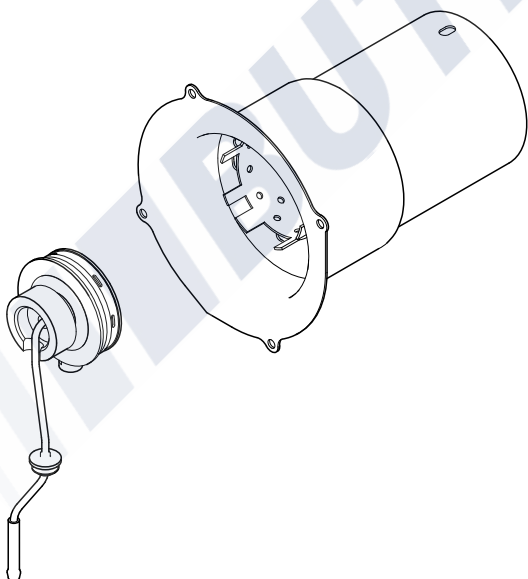

Fig. 205 Burner insert (diesel) and combustion chamber

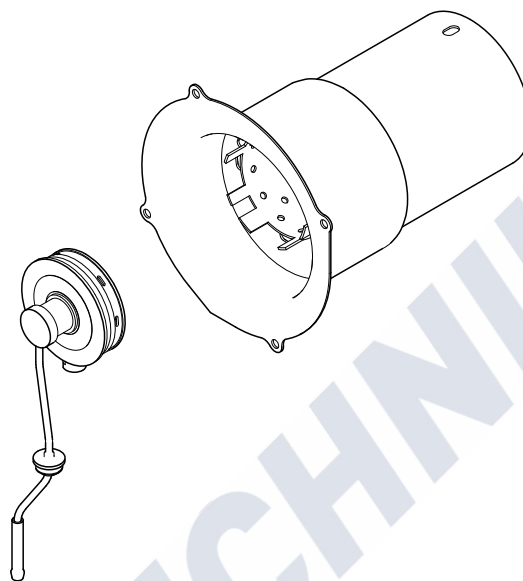

Fig. 206 Burner insert (petrol) and combustion chamber

2.4 Control unit

The control unit is the central component for ensuring the function is maintained and for monitoring the heater's operation. A temperature sensor in the control unit is designed to control the room temperature. An external temperature may also be connected to all the heaters.

If a fault occurs, an error code will be output in the display of the combination timer. If the heater has a control element, the ON control light will flash. In addition the heater can be checked using a personal computer (see PC heater diagnostic operating manual).

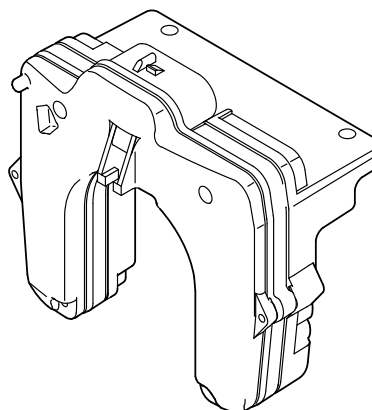

Fig. 207 Control unit

2.5 Glow plug / Flame monitor

The glow plug also acts as a flame monitor. The mixture of fuel and air is ignited by the glow plug when the heater is started. The glow plug takes the form of an electrical resistor and is positioned in the burner on the side facing the flame.

As a flame sensor the glow plug reacts in the same way as a low ohm PTC resistor, which changes its resistance depending on the heat emitted by the flame. The signals are fed to the control unit where they are processed.

The flame status is monitored by the flame sensor whenever the heater is operating.

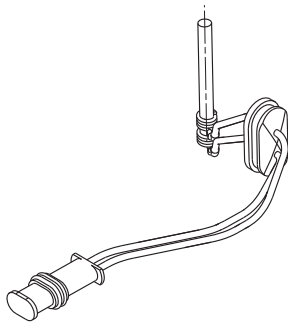

Fig. 208 Glow plug / Flame monitor

2.6 Overheating sensor

The overheating sensor measures the temperatures in the rib area of the heat exchanger whenever the heater is operating.

The control unit evaluates the signal and protects the heater from hot air outlet temperatures above 150 °C and surface temperatures above 80 °C by shutting down the combustion process and blowing cold air over the heater. The heater then suffers a fault lock-out and can be restarted by being switched off and on again (see 3.2).

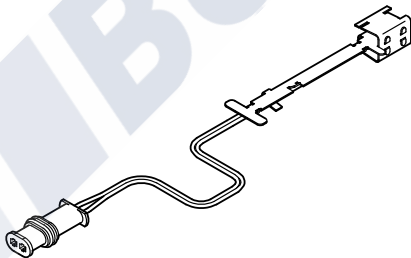

Fig. 209 Overheating sensor

2.7 Metering pump

The metering pump is a combined transport, metering and shut-off system for supplying fuel from the vehicle's tank to the heater.

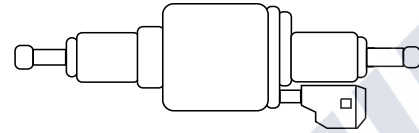

Fig. 210 Metering pump DP2 / DP 30.2

3 Function Description

3.1 Control element

The control element is designed to switch the heater on and off, adjust the required room temperature (intake temperature between approx. 5 °C and 35 °C) and to reset the heater after a fault.

In addition, other comfort functions (Eco, Normal, Plus, Ventilation, Altitude Compensation) can also be activated with the MC04/05 heater control.

The integral green LED is designed to act

- as an ON signal,
- as a fault signal,
- as service display (LED flashes).

NOTE

ADR operation:

After an operating voltage has been applied by switching the battery isolation switch and control element to "ON", the control unit will be set to the "Fault lock-out" position. Before it can be restarted, the control element must be set to "OFF".

3.2 Operating modes of heater

The Air Top Evo 3900 and Air Top Evo 5500 can be activated with the heater controls rotary selector, combination timer or MC04/05.

3.2.1 Comfort heating

Comfort functions (Eco, Plus, Altitude Compensation and Ventilation) can be selected manually with the MC04/05 heater control. They can be implemented in special heater variants.

3.2.2 Eco mode

This is a specific energy-saving mode. The heater will operate at approx. 70 % of its maximum output. This reduces both fuel and electrical consumption. This mode is especially used for maintenance heating.

3.2.3 Plus mode

The heater is operated for a limited time at an increased heating capacity of 110 % to enable fast heat-up. When the set temperature is reached, the heater automatically switches back to its normal capacity. The increased heating capacity can also be switched on during ongoing operation if necessary (sudden drop in temperature due, for example, to opening the cab door). The maximum duration of the increased heating capacity is 60 minutes for the Air Top Evo 3900 and 30 minutes for the Air Top Evo 5500

(continuously or in time increments).

3.2.4 Altitude compensation

With the altitude compensation function, optimum combustion operation at over 1,200 m up to 2,200 m above sea level is achieved (the air becomes thinner, the CO₂ content rises, the fan speed increases and the heating capacity and metering pump frequency are reduced). In special variants, a pressure sensor assumes the automatic altitude control.

3.2.5 Ventilation

The fan speed for the fresh air supply is adjusted with the temperature selector.

IMPORTANT

If the heater is in combustion operation, an approx. 3 minute long cooling phase is carried out before ventilation is activated.

3.3 Switching on

Set the control element to the required temperature.

If the hot air temperature is lower than the nominal temperature the heater will start

NOTE

If the temperature of the hot air intake is above the set nominal temperature, only the motor for the hot and combustion air blower will start (control pause). Special feature: The control pause speed is 0 rpm if an external temperature sensor is used (not with special variants).

The function of the flame sensor is checked. If the flame sensor now reports "light", the system will attempt to cool the flame sensor for 60 seconds. If the flame sensor still reports "light" the control unit will suffer a fault lock-out. If another monitored component has suffered a fault, the fault lock-out will take effect without any slow down time.

Start

When the heater is switched on the ON signal light will be lit and the glow plug will be switched on (cycled). The motor for the hot and combustion air blower will be set to approx. 50% of its maximum speed.

After approx. 40 seconds the fuel metering pump will start and the flame formation will begin. To improve the starting quality, the metering pump and combustion air blower are started with different frequencies and speeds. After a further 90 seconds the glow plus will be switched off and the existence of the flame established.

Automatic restart

If the flame sensor does not find a flame, the starting procedure will be repeated. The glow plug will be switched on again (cycled). The motor for the hot and combustion air blower will be set to approx. 50% of its maximum speed.

After approx. 40 seconds the fuel metering pump will start and the flame formation will begin.

After a further 50 seconds the glow plus will be switched off and the existence of the flame established.

If the heater has again failed to ignite properly, the it will be shut down using a fault slow down procedure at maximum speed after 180 seconds and will suffer a fault lock-out.

NOTE

After a restart the heater will suffer a fault lock-out. To reset the fault switch the heater off briefly (at least 2 seconds) and then on again.

3.4 Heating mode

Whilst the heater is operating the combustion gases pass through the heat exchanger. During this process the combustion heat is given off to the walls of the heat exchanger, absorbed by the hot air transported by the hot air fan and fed into the interior of the vehicle.

The temperature of the hot air intake is measured by a temperature sensor in the control unit or an external temperature sensor. If the measured temperature is lower than the value set on the control element, the output of the heater is increased to maximum heat output.

To increase the burner service life when it is used continuously the transport capacity of the metering pump is reduced for 10 seconds every 10 minutes.

In addition, the heating mode is briefly interrupted after every 8 hours and then automatically restarted in the same way as for a control pause. This ensures controlled combustion operation.

3.5 Control mode

In the control mode the fan speed and the metering-pump pumping quantity are dependent on the heating capacity. The glow plug is off.

3.6 Control pause

After the temperature set on the control element has been reached the heat output is reduced. The speed of the heating and combustion air blower and the delivery rate of the metering pump are reduced.

If, at minimum heat output, the intake temperature set on the control element is exceeded, the metering pump is shut down and the combustion process ended. To burn off the flame properly the blower speed falls after 20 seconds to low-fire rate speed and then returns to the initial speed after 15 seconds, after which it falls to the control pause speed in 3 minutes, where it remains for the entire control pause. The control pause speed is 0 if an external temperature sensor is used.

If the temperature set on the control element is exceeded at the temperature sensor, the heater will restart.

NOTE

Changes to the setting on the control element are implemented by the control unit and heater after a delay.

3.7 Switching off

When the heater is switched off the ON control LED on the control element goes out. If no fuel has been transported yet or if the heater is in the control pause, the heater is switched off immediately without a run-on period.

If the fuel transport has been started it is ended when the heater is switched off. The heater is switched off using the same method as the transition from control mode to control pause. The heater is then switched off automatically.

NOTE

The heater may be switched on again during the slow down time. In this case the slow down time is completed and the heater is then restarted.

3.8 Functions of Air Top Evo AM System

3.8.1 System design

The Air Top Evo 3900 Automatic AM Diesel and Air Top Evo 5500 Automatic AM Diesel variants offer the option of operating up to 4 heaters in one system. Here Unit 1 is defined as the master heater and others as slave heaters. The heater control and an external temperature sensor (T) are connected to the master heater (see wiring diagram in Figure Fig. 707).

The slave heater is connected as shown in the wiring diagram (see Fig. 708) . The units communicate with each other via a serial bus system.

This system can therefore be individually adapted to the applications by combining several heaters.

IMPORTANT

The use of an Air Top Evo 3900 AM or Air Top Evo 5500 AM system is not approved for dangerous goods transports (ADR)!

3.8.2 Initial Installation/Initial Operation**Installation**

1. Installation of the heaters according to installation instructions for Air Top Evo 3900/5500
2. Ensure that the electrical connections are in accordance with the system wiring diagram (Fig. 707, Fig. 708, Fig. 711)
3. Installation of heater control and external temperature sensor

Initial start-up

1. Start master heater with controls
=> Master heater "starts up"
2. Produce connection between Master and Slave 1 (see system wiring diagram)
=> Slave 1 heater switches into "Ventilation" state
3. Produce connection from Slave 1 to Slave 2 (see system wiring diagram)
=> Slave 2 heater switches into "Ventilation" state
4. Teach additional slave heaters (repeat Point 2 and 3)
5. Switch off master heater with heater control
=> Initial start up completed

NOTE:

Teaching a slave heater is only possible for a limited time (120 sec)! If this time is exceeded, teaching is no longer possible and the system must be reset.

3.8.3 Resetting Master/Slave System

If for some reason (communication error, time expired, etc.) teaching is not continued, it is possible to reset the system to the original state.

1. Switch master heater into "Ventilation"
2. De-energise/pull fuse

NOTE:

All connected heaters must be disconnected from Terminal 30!

3. Connect voltage and repeat teaching process (see "Initial installation/Initial operation").

3.9 Heater functions when installed in ADR vehicles**NOTE 24V**

Only for Air Top Evo 3900/5500 D heaters that are installed in vehicles for transporting hazardous substances (ADR).

If the heater is switched off using the control element the slow down time remains unchanged.

A brief slow down time (max. 40 seconds) is started automatically if

- the vehicle's engine is switched off
- a transport device is started.

After an ADR shut down process the control unit is in the "Fault lock-out" position. Before it can be restarted the control element must be set to "OFF".

3.9.1 Extract of the directives 2001/56/EG Annex IX and ECE R122 Annex 9

Start of extract.

ANNEX IX / 9**3. Technical specifications for heater units for installation in dangerous goods transporters (Annex 9)****3.1. General (EX/II, EX/III, AT, FL and OX vehicles)**

3.1.1. The combustion heaters and their exhaust gas routing shall be designed, located, protected or covered so as to prevent any unacceptable risk of heating or ignition of the load. This requirement shall be considered as fulfilled if the fuel tank and the exhaust system of the appliance conform to the provisions set out in the points 3.1.1.1 and 3.1.1.2. Compliance with those provisions shall be verified on the completed vehicle.

3.1.1.1. Any fuel tanks for supplying the appliance shall meet the following requirements:

- d) in the event of any leakage, the fuel shall drain to the ground without coming into contact with hot parts of the vehicle or the load;
- e) fuel tanks containing petrol shall be equipped with an effective flame trap at the filler opening or with a closure enabling the opening to be kept hermetically sealed.

3.1.1.2. The exhaust system as well as the exhaust pipes shall be so directed or protected to avoid any danger to the load through heating or ignition. Parts of the exhaust system situated directly below the fuel tank (diesel) shall have a clearance of at least 100 mm or be protected by a thermal shield.

3.1.2. The combustion heater shall be switched on manually. Programming devices shall be prohibited.

3.2. EX/II and EX/III vehicles

Combustion heaters using gaseous fuels are not permitted.

3.3. FL vehicles

3.3.1. The combustion heaters shall be put out of operation by at least the following methods:

- a) intentional manual switching off from the driver's cab;
- b) stopping of the vehicle engine; in this case the heating device may be restarted manually by the driver;
- c) start-up of a feed pump on the motor vehicle for the dangerous goods carried.

End of extract.

3.10 Fault lock-out

Errors on the various heater components and faults in the starting process and in heating mode are identified in the control unit. The heater is switched off and goes into fault lock-out if the following conditions occur:

- No or incorrect start
- Temperature sensor defective
- Overheating sensor interrupt or short circuit
- Overheating sensor installed incorrectly
- Glow plug/Flame monitor interrupt or short circuit
- Fan motor overload or blocked or short circuit or interrupt
- Error in metering pump circuit
- Undervoltage below 10.5 V/21 V for longer than 20 seconds
- Overvoltage above 16 V/32 V for longer than 6 seconds
- Control unit defective
- Overheating

The fuel supply is stopped if the heater overheats.

The heater continues to run in the same way as if it is switched off manually.

After it stops the control unit will be set to fault lock-out. The overheating is indicated by the indicator flashing 10 times.

Rectify the cause of the fault.

To reset the fault switch the heater on and off briefly (at least 2 seconds).

3.10.1 Error monitoring

The overheat, incorrect start and flame failure errors are counted and cause the heater to suffer a fault lock-out after an error has occurred the maximum number of times.

The incorrect start counter FSZ is incremented by 1 each time the heater fails to start. If the incorrect start counter reaches its maximum value of 9 the heater will go into the heater lock-out status HGV.

The error counter SZ is incremented by 1 each error for which there is no separate counter. If the error counter reaches its maximum value of 5 the heater will go into the heater lock-out status HGV.

The overheating counter ÜHZ is incremented by 1 each time the heater overheats. If the overheating counter reaches its maximum value of 5 the heater will go into the heater lock-out status HGV.

After a flame abort FAZ, a restart is automatically carried out. The condition for a restart is that the heater was in the control mode directly beforehand. During the restart the cycle repetition counter ZWZ is increased by one. This process is repeated until the heater either burns properly again or the maximum value of 3 for the cycle repetition counter has been reached.

The flame abort counter FAZ is increased by 1 when the cycle repetition counter ZWZ has reached the maximum value. If the flame abort counter reaches its maximum value of 3 the heater will go into the heater lock-out status.

Automatic reset:

Following each heater start-up, the cycle repetition counter ZWZ is set to 0. The fault counter is set to 0 after a fault-free transition to the control mode and the flame abort counter FAZ, overheating counter UHZ, false starting counter FSZ and cycle repetition counter ZWZ are set to 0 after(!) fault-free combustion operation (20 min.).

3.10.2 Reset a fault lock-out

The various fault statuses can be reset as follows.

Fault lock-out: Switch off heater with heater control, wait at least 2 seconds and switch back on.

Heater fault lock-out: When heater is switched on Fault code F12 is displayed. Remove fuse. Switch off heater with heater control. Insert fuse again after more than 2 seconds. Switch on heater again with heater control.

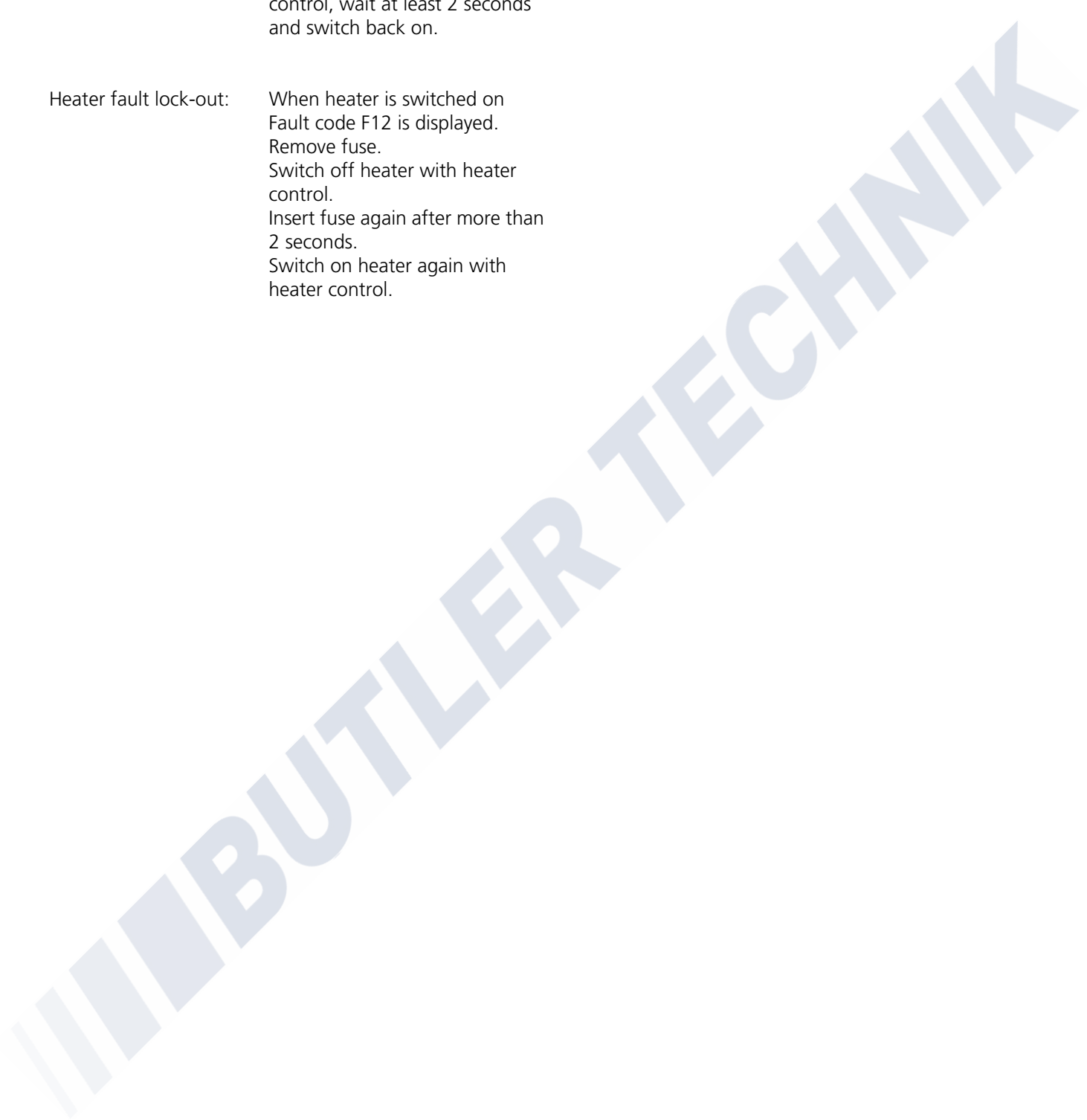

4 Technical data

Except where limit values are specified, the technical data listed in the table refer to the usual heater tolerances of ±10% at an ambient temperature of +20 °C and at the rated voltage and in rated conditions.

Electrical components:

The control unit, combustion air blower, metering pump, timer*, glow plug/flame monitor and control element are designed for 12 V or 24 V. The voltage is immaterial for the temperature sensor.

* not for ADR

Fuel for Air Top Evo 3900/5500 B (petrol):

The fuel specified by the manufacturer in accordance with DIN EN 228 must be used

Fuel for Air Top Evo 3900/5500 D (diesel/PME):

The diesel fuel specified by the manufacturer in accordance with DIN EN 590 must be used

We know of no negative influences due to additives.

If fuel is extracted from the vehicle's tank, follow the additive instructions issued by the vehicle manufacturer.

If you change to low-temperature fuel, the heater must be operated for approx. 15 minutes so that the fuel system is filled with the new fuel.

The Air Top 3900/5500 ST D heater is also licensed for use with PME (bio-diesel), which complies with DIN EN 14214.

In the table (Fig. 401), the values in brackets stand for the expanded heating capacity "Plus", which can be activated with the MC heater control.

Heater	Operation	Air Top Evo 3900 B	Air Top Evo 5500 B	Air Top Evo 3900 D	Air Top Evo 5500 D
Type test permit		EMC: e1*72/245*2006/96*5529*__ (Air Top Evo 3900/5500) E1 03 5529 (Air Top Evo 3900/5500) Heater: e1*2001/56*2006/119*0255*__ (Air Top Evo 3900) E1 00 0255 (Air Top Evo 3900) e1*2001/56*2006/119*0256*__ (Air Top Evo 5500) E1 00 0256 (Air Top Evo 5500)			
Model		Air heater with evaporation burner			
Heat output	Control range	1.7 - 3.5 (3.9) kW	1.7 - 5.0 (5.5) kW	1.5 - 3.5 (3.9) kW	1.5 - 5.0 (5.5) kW
Fuel		Petrol EN 228		Diesel/PME EN 590 DIN EN 14214	
Fuel consumption	Control range	0.18 - 0.37 (0.41) kg/h 0.23 - 0.48 (0.54) l/h	0.18 - 0.52 (0.57) kg/h 0.23 - 0.69 (0.75) l/h	0.16 - 0.37 (0.41) kg/h 0.19 - 0.44 (0.49) l/h	0.16 - 0.52 (0.57) kg/h 0.19 - 0.63 (0.69) l/h
Rated voltage		12 V		12/24 V	
Operating voltage range		10.5 - 16 V		10.5 - 16 V/20.5 - 31 V	
Rated power consumption	Control range	15 - 40 (55) W	15 - 95 (130) W	15 - 40 (55) W	15 - 95 (130) W
Permissible ambient temperature:					
Heater	– Operation – Storage	–40 °C - +40 °C –40 °C - +85 °C			
Metering pump	– Operation – Storage	–40 °C - +20 °C –40 °C - +85 °C			
Heater control	– Operation – Storage	–40 °C - +75 °C –40 °C - +85 °C			
Permissible combustion-air intake temperature		–40 °C - +20 °C			
Adjustment range for interior temperature	Control range	+5 °C - +35 °C			

Fig. 401 Technical data of Air Top Evo 3900/5500

Technical data

Air Top Evo 3900/5500

Heater	Operation	Air Top Evo 3900 B	Air Top Evo 5500 B	Air Top Evo 3900 D	Air Top Evo 5500 D
Volume flow of hot air	against 0.5 mbar	max. 132 (139) m ³ /h	max. 200 (220) m ³ /h	max. 132 (139) m ³ /h	max. 200 (220) m ³ /h
CO ₂ in exhaust gas (permitted function range)		1.7 kW: 5.0 - 8.0 % 3.5/5.0 kW: 9.0 - 12.5 %		1.5 kW: 6.5 - 8.0 % 3.5/5.0 kW: 9.0 - 12.5 %	
Heater dimensions			Length Width Height	423 ± 2 mm 148 ± 1 mm 162 ± 1 mm	
Heater weight		5.9 kg			

Fig. 401 Technical data of Air Top Evo 3900/5500

Setpoint values:

		12 V	24 V
Glow plug	At 25 °C Test current: < 5 mA	No marking 0.190 - 0.250 ohms	Green marking 0.740 - 0.940 ohms
Drive unit	Outside	< 6 ohms	
Overheating temperature sensor	at 25 °C	2,195 ohms	
External temperature sensor	at 25 °C	10,000 ohms	
Undervoltage switch-off (triggering time > 20 s)		≤ 10.5 V	≤ 20.5 V
Oversvoltage switch-off (triggering time > 6 s)		≥ 15 V	≥ 31 V

Fig. 402 Setpoint values for resistance values of components

5 Troubleshooting

5.1 General

This section describes how to identify and deal with errors on the Air Top Evo 3900 and Air Top Evo 5500 heaters.

If a fault occurs, an error code will be output in the display of the combination timer.

If the heater has a control element, the ON control light will flash.

In addition the heater can be checked using a personal computer (see PC heater diagnostic operating manual).

IMPORTANT

Troubleshooting work demands precise knowledge of the structure and theory of operation of the various components and must be carried out by trained personnel only. If in doubt, refer to sections 2 and 3 for a description of how the functions interact.

NOTE

For ADR mode only

After an ADR shut-down or an operating voltage has been applied by switching the main vehicle switch and control element to "ON" the control unit will be set to the "Fault lock-out" position. Before it can be restarted the control element must be set to "OFF" or the Immediate heat button pressed on the combination timer.

IMPORTANT

The troubleshooting guide is restricted to the localisation of defective components.

The following potential sources of malfunctions are not taken into account and should always be checked so that they can then be excluded as the cause of the particular fault:

- **Corroded plugs**
- **Loose plug contacts**
- **Poor crimp contacts on plugs**
- **Corroded cables and fuses**
- **Corroded battery terminals**

If you wish to check individual components, the electrical plug connectors on the control unit must be disconnected.

Conduct a function test in the vehicle after rectifying each fault.

5.2 General error symptoms

The following table (Fig. 501) lists the possible error symptoms.

Error symptom	Possible cause	Remedy
Heater unit cuts out automatically	No combustion after start and restart ON indicator flashes	Switch heater off and then on again
	Flame extinguishes during operation ON indicator flashes	Switch heater off and then on again
	Heater unit overheats ON indicator flashes	Check that the hot air system is clear, allow the heater to cool, switch heat off briefly and then on again
	Vehicle voltage too low ON indicator flashes	Charge battery Switch heater off and then on again
Heater unit emits black smoke	Combustion air and/or exhaust system blocked	Check that the combustion air and exhaust systems are clear

Fig. 501 General error symptoms

5.3 Error symptoms during function

The following table (Fig. 502) lists the possible error symptoms in the order in which they may occur during operation.

In the event of a fault, the error is to be located using this table and rectified. It is important that the error symptom is correctly identified.

If the error symptom is not included in this table or if the fault is not found under the specific error symptom heading,

in an emergency you can contact our technicians on our service hotline.

NOTE

Every fault is indicated by the flashing LED on the control element after the slow down time has finished. If the other components are OK, a defective control unit may be the cause of all the faults.

There are states which are equivalent to faults.

Error symptom	Occurrence	possible causes
No start and no illumination of the LED on the control element	immediate	Incorrect cabling, defective fuse
No start but LED is lit	immediate	The unit immediately goes into a control pause when switched on; the control pause speed is 0 rpm when an external temperature sensor is used.

Fig. 502 Error symptoms during function

5.4 Error code output

If the heater is fitted with a combination timer, an error code output will appear on the display of the timer after a fault occurs.

NOTE

The error code is output if the heater is fitted with a control element after an error has occurred by the switch-on indicator/error code indicator flashing. After 5 seconds of fast flashing, the error code will be output by a sequence of long flash pulses, the number of flashes is shown in the table below (for example F04 = 4 long flash pulses).

Error code	Error (group)	Additional information during PC diagnostic	Troubleshooting
F 00	Control unit error/ incorrect parameter set/ warm-start detection	01 Control unit error 81 EOL checksum error 11 Incorrectly coded control unit or incorrect heater (fuel type) installed (the heater will not work if this error occurs) 91 Neutrally coded or disabled control unit (the heater will not work if this error occurs) 92 Maintain command failed (the heater will not work if this error occurs). 18 Customer bus defective	Replace control unit
F 01	No start (after 2 starting attempts)/ no flame formation	02 Even after the restart, no flame has formed 82 No start in test	Check fuel supply (tank empty, lines blocked) Clean burner insert, replace flame sensor
F 02	Flame abort (repeated >3)	03 The flame has gone out during operation and has not reformed after a restart attempt 83 The flame has gone out during a heating cycle more than FAZ times (EEPROM)	Check fuel supply (tank empty, lines blocked) Clean burner insert, replace flame sensor
F 03	Undervoltage or overvoltage	84 The voltage was less than 10.5 V or 21 V for longer than 20 seconds 04 The voltage was more than 16 V or 32 V for longer than 6 seconds	
F 04	Premature flame recognition	05 The flame sensor recognised a flame before combustion had started	Replace flame sensor
F 06	External temperature sensor break or External temperature sensor short circuit	14 Temperature sensor circuit short circuit to earth 94 Temperature sensor circuit break or short circuit to +Ub	Check cables, replace temperature sensor Check cables and terminating resistor, replace temperature sensor

Fig. 503 Troubleshooting (Page 1 of 2)

Error code	Error (group)	Additional information during PC diagnostic	Troubleshooting
F 07	Metering pump interrupt or metering pump short-circuit	88 Break or short circuit to +Ub 08 Short circuit to earth	Check cables, replace metering pump Check cables, replace metering pump
F 08	Fan motor interrupt or fan motor short-circuit or fan motor overload or fan motor blocked	89 Break or short circuit to +Ub 09 The switched drive unit cable (combustion and hot air blower) has a short circuit to earth or the drive unit is overloaded 15 Burner motor block guard has tripped 95 Burner motor not turning easily sensor has tripped	Check magnets Replace drive unit (combustion and hot air blower) Eliminate the cause of the blockage / difficulty in movement Replace drive unit (combustion and hot air blower)
F 09	Glow plug interrupt or glow plug short-circuit	8A Glow plug/Flame monitor: Break or short circuit to +Ub 19 Glow circuit: The switched cable of the element has a short circuit to earth	Replace glow plug / flame monitor Replace glow plug / flame monitor
F 10	Overheating	06 The overheating fault lock-out has tripped (heater overheated) 17 Incorrect application or illegal insulation (OHS gradient too high)	Find and remove the cause of the overheating NOTE If no other cause can be found for the overheating, the pressure losses caused by the hot air distribution (too many resistance points) are too high or a hot air filter is soiled
F 11	Overheating sensor interrupt or overheating sensor short circuit	AB Overheating sensor circuit: break or short circuit to +Ub 1B Overheating sensor circuit: the switched cable of the element has a short circuit to earth	Replace overheating sensor Replace overheating sensor
F 12	Heater unit lock-out	07 The permanent heater fault lock-out has been activated	Heater unit is switched on, Fault code F12 is shown. Remove fuse. Switch off heater unit with heater control. Insert fuse again after more than 2 seconds. Switch on heater unit again with heater control. NOTE The following error has occurred several times: Fault counter more than 5 times Incorrect start counter more than 9 times Flame failure counter more than 5 times
F 14	Overheating sensor incorrect position	97 Incorrect position of the overheating sensor (OHS gradient too low)	Position the overheating sensor correctly
F 15	Setpoint generator short circuit	9B Nominal value potentiometer circuit break or short circuit to + Ub	Check cables, replace control element

Fig. 503 Troubleshooting (Page 2 of 2)

6 Function Tests

6.1 General

This section describes the tests conducted on the heater when it is installed and not installed to verify that it is in working order.

WARNING

The heater must not be operated in enclosed areas such as garages and workshops without an emissions extraction system.

6.2 Required test and measuring equipment

The test and measuring equipment must be calibrated and proof of measuring certificates must be available.

Digital multimeter

Testing of electrical resistance [ohms], electrical continuity ≤ 0.1 ohms
Test current < 5 mA

Voltage source, adjustable

Measuring of electrical voltage [V]
10 - 30 V
 ≥ 30 A

CO₂ measuring unit

Testing of CO₂ value [vol. %]
Maximum ± 0.3 vol. %

Heater test bench *1)

Heater function test
Regarding contact Webasto heater test bench:
International Technical Support - International Hotline:
hotline@webasto.nl

PC (personal computer)

System requirements:

- IBM-compatible PC, 486 or higher in accordance with the operating system requirements
- Main memory ≥ 8 MB in accordance with the operating system requirements
- Microsoft Windows 98, ME, NT4, 2000, XP or newer versions
- COMCTL32.DLL, Version 4.70 or higher (can be downloaded on the Internet (<http://www.microsoft.com>))
- 3 MB of free memory on the hard disk
- a free COM port (RS232C) or a free USB port
- Optional: Internet connection (for software updates)
- Webasto Thermo Test does not run under Windows 3.1 with Win32s

Webasto Diagnosis Adapter incl. software

Diagnosis Adapter ID No. 9009064_ is available from Webasto Thermo & Comfort SE.
Display of fault memory, operating data and control unit information.

Reference heater Air Top Evo 3900/5500

The reference heater must be subjected to continual operating checks.

*1)

The following schematic diagram shows the components necessary for operating a heater. Application-specific interfaces must be taken into account. A calibrated metering pump, which is subjected to continual operating checks, must be used for testing. The technical requirements are contained in the Webasto product documentation. It is preferable to use Webasto components. Particular attention must be paid to work and occupational safety.

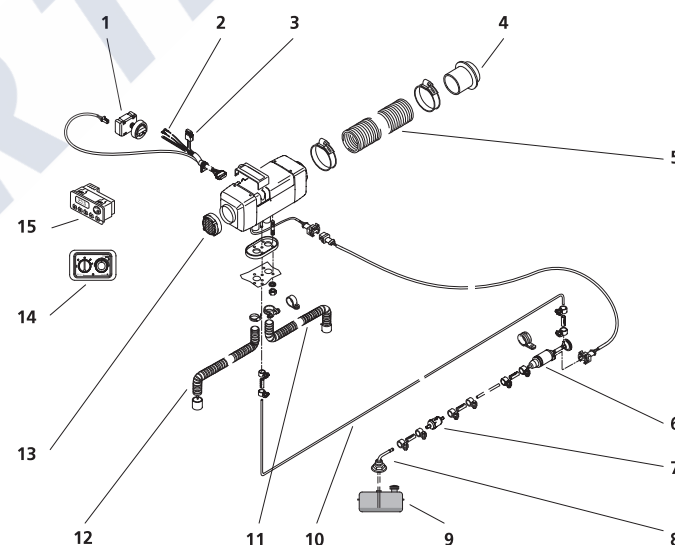

- | | |
|--------------------------------|-------------------------------|
| 1 Setpoint generator | 8 Fuel standpipe |
| 2 Electrical vehicle interface | 9 Fuel tank |
| 3 Heater fuse | 10 Fuel line |
| 4 Hot air outlet | 11 Exhaust pipe |
| 5 Heating-air outlet hose | 12 Combustion-air intake pipe |
| 6 Metering pump | 13 Heating-air intake grill |
| 7 Fuel filter | 14 Multi Comfort Control |
| | 15 Combination timer |

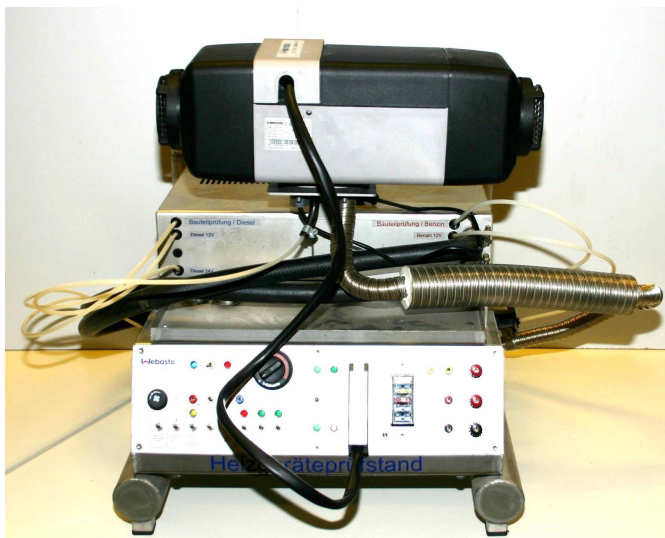

6.3 Settings

6.3.1 Setting CO₂ content

The CO₂ content in the emissions is set using the temperature selector on the control element. Activate any desired heating mode (Eco, Normal or Plus) in the process with the MC04/05 heater control.

IMPORTANT

The CO₂ measuring instruments must be calibrated. The heater must be switched off.

1. Connect the CO₂ line to minus.
2. Turn the adjustment knob on the control element to the centre setting. The heater will start and go automatically to low-fire rate mode.

NOTE

If the heater can be adjusted the operating indicator will flash as if the control unit has suffered an error.

Diesel units:

3. Set the CO₂ value by turning the adjustment knob. Turning it anticlockwise will reduce the CO₂ value, whilst turning it clockwise will increase it. The measured CO₂ content at partial load (1.5 kW) must be between 5.0 % and 8.0 %. At full load the CO₂ content is to be 10.3 +/- 0.5 vol. % after adjustment.

Petrol units:

3. The CO₂ content may only be adjusted with the unit at operating temperature. The unit must be operated for at least 8 minutes for this purpose. Then the CO₂ content must be set to 6.1 to 6.3 vol. % at partial load (1 KW). At full load the CO₂ content is to be 9.9 +/- 0.4 vol. % after adjustment.

Diesel and petrol units:

4. If the CO₂ value is in the permissible range, disconnect the CO₂ line from minus. This saves the setting.

NOTE

The heater will now run in normal mode again and can be switched off as normal using the control element. The heater is set at the factory to match the fitted combustion air blower.

6.3.2 CO₂ setting of reference heater

The reference heater is set to 10.3 vol. % CO₂ at a geodetic altitude of 0 metres at the factory. For later resetting, a CO₂ value must be set in accordance with the following table as per the geodetic altitude.

Also see paragraph 6.3.1.

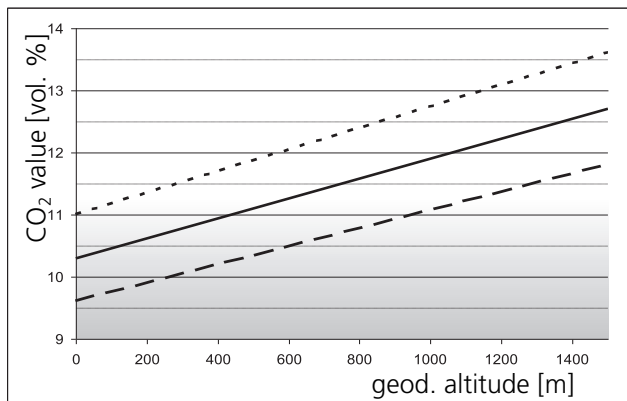

—	CO ₂ [vol. %]
- -	min. tolerance for operation [vol. %]
- . - .	max. tolerance for operation [vol. %]

6.4 Testing individual components

IMPORTANT

For function tests always disconnect the connection between the control unit and the component to be tested.

NOTE

If an error occurs which cannot be detected with this procedure, the unit/component must be sent in to the Webasto Warranty Department.

For details please contact your Webasto representative.

NOTE



Damage caused by soiling will not be recognised by Webasto!

Graph legend

- ① Repair/replace component. Send component to Webasto within the warranty period.
- ② Repair/replace component if necessary and put heater into operation.
- ③ Repair/replace component. Only send defective component (not entire heater) to Webasto within warranty period.

6.4.1 Burner component

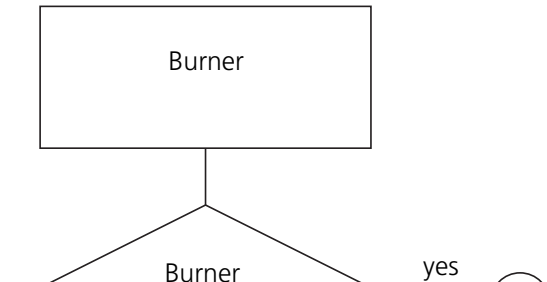
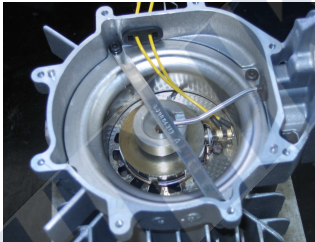
See Fig. 904, Item 33 and Item 7

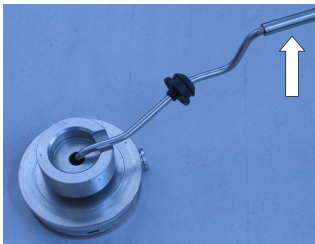
Procedure	Testing and measuring equipment	Visual
		
<p>yes 2</p> <p>no</p>	<p>Visual inspection</p>	
<p>no</p> <p>No blockages in the fuel pipe?</p>	<p>no 1</p> <p>Blow through with breathing air</p>	
<p>no 1</p> <p>Check function on heater test bench</p>	<p>Conduct function test with reference heater. Set reference unit to nominal CO₂ value locally after 5 minutes of full-load operation in accordance with the graphic, install the burner to be tested in the reference unit and measure the CO₂ value after 5 minutes of full-load operation</p>	
<p>no 1</p> <p>Can CO₂ value be adjusted with to the correct value?</p>	<ul style="list-style-type: none"> - Heater test bench - CO₂ measuring unit - Webasto Diagnosis Adapter - PC (personal computer) - Reference heater 	
<p>yes 2</p>		

6.4.2 Combustion and hot air fan component

See Fig. 903, Item 1

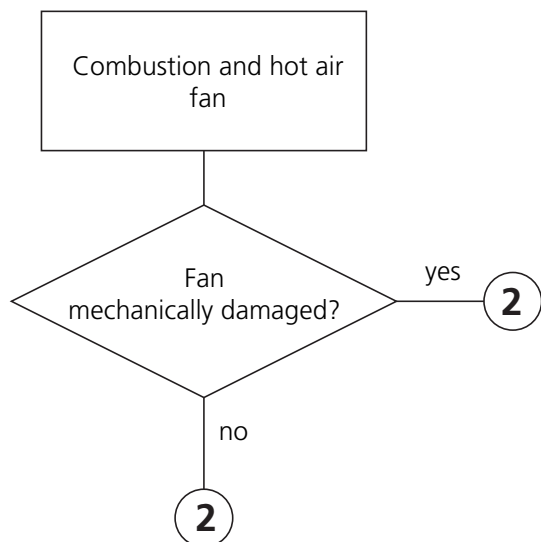

Procedure	Testing and measuring equipment	Visual
Visual inspection – Deformation – Magnets present – Plastic broken		

6.4.3 Glow plug component

See Fig. 904, Item 8

NOTE

The resistance test must be carried out with an ohmmeter suitable for small resistance values. A resistance test with a simple digital multimeter is too inaccurate to find the precise values. A new glow plug can be measured to act as a reference.

The glow plug should have the following values in the test:

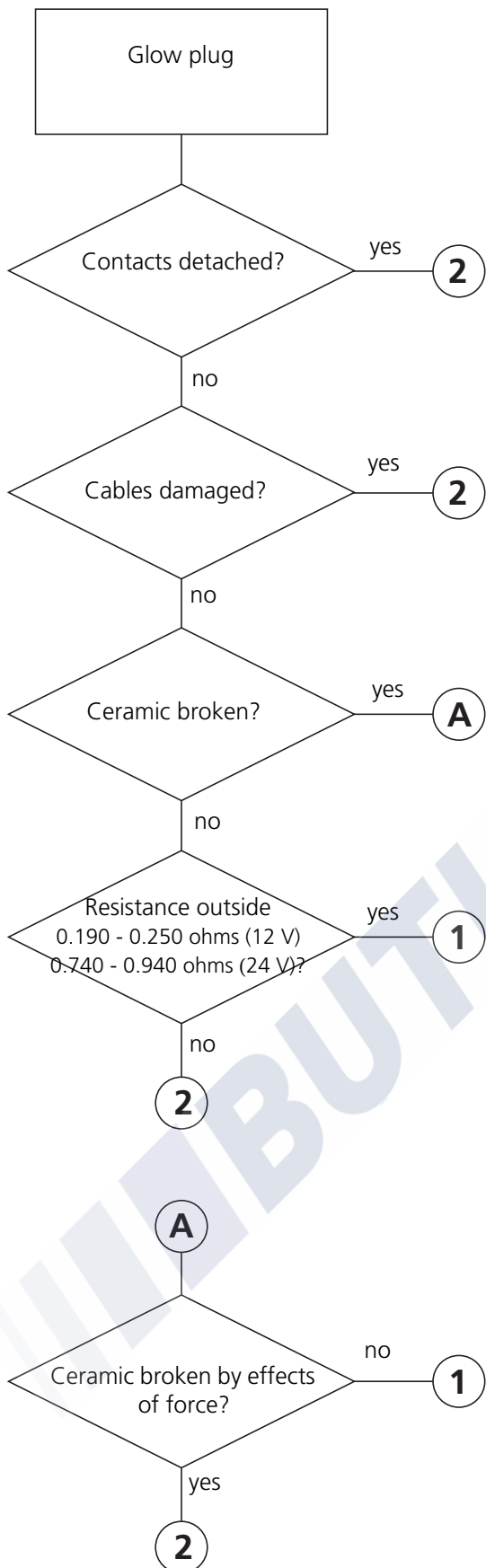

Glow plug:	12 V (no marking)	24 V (green marking)
Resistance at 25 °C:	0.190 - 0.250 ohms	0.740 - 0.940 ohms
Test current:	< 5 mA	<5 mA

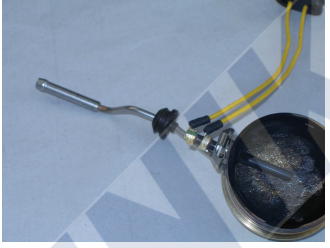
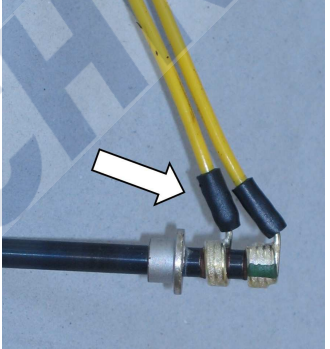
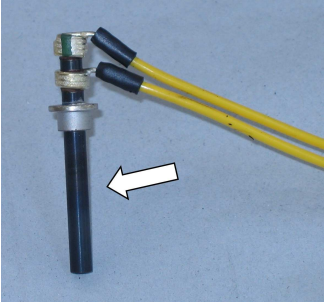

Procedure	Testing and measuring equipment	Visual
Visual inspection		
Visual inspection		
Visual inspection		
Resistance measurement	Digital multimeter	

6.4.4 Drive component

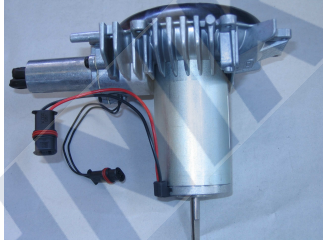
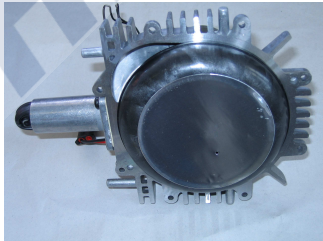
See Fig. 903, Item 1

Drive unit	Procedure	Testing and measuring equipment	Visual
<p>Externally damaged?</p> <p>yes 2</p> <p>no</p>	Visual inspection		
<p>Installation of component in unit => short circuit to metal parts (heat exchanger etc.)?</p> <p>yes 1</p> <p>no</p>	Continuity measurement	Digital multimeter	
<p>Resistance outside 0 - 6 ohms?</p> <p>yes 1</p> <p>no</p>			
<p>Start at 10/16 V?</p> <p>no 1</p> <p>yes</p>	Motor start-up	Voltage source	<p>IMPORTANT</p> <p>Ensure correct polarity (+)/(-)</p> <p>(-) = black</p> <p>(+) = red</p>
<p>Bearing noises?</p> <p>yes 1</p> <p>no</p>	Subjective test		
<p>2</p>			

6.4.5 Overheating sensor component

See Fig. 903, Item 8

If you conduct this resistance test with a digital multimeter, the overheating sensor must have the values shown in the following diagram:

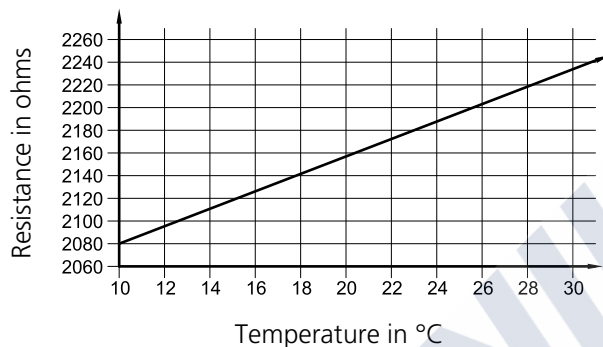
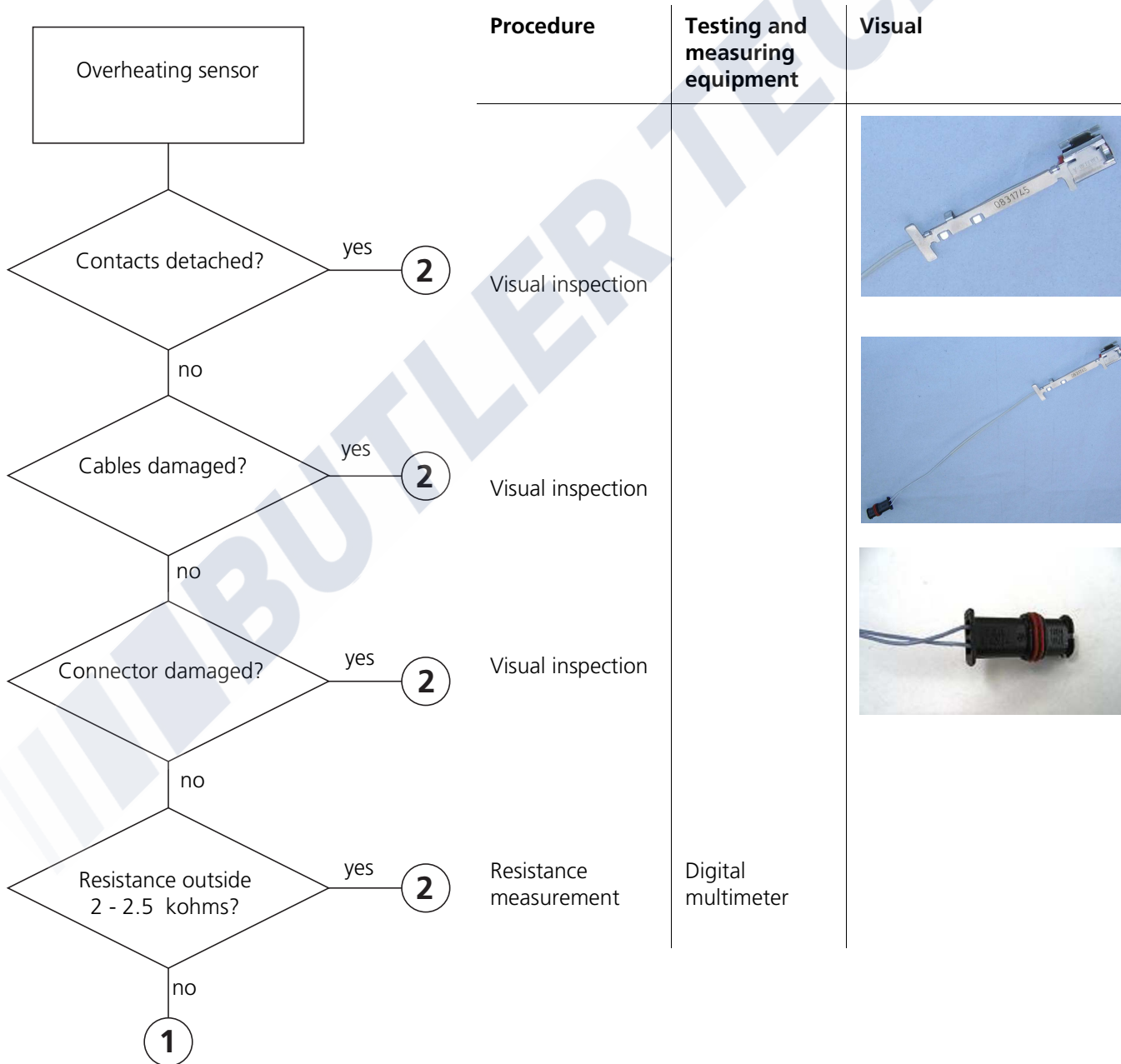
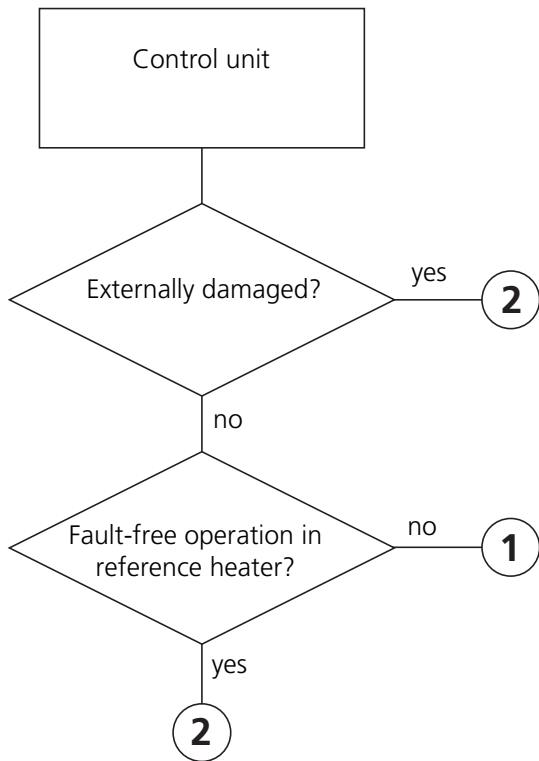



Fig. 601 Characteristic resistance values of a PT 2000 overheating system in a temperature range of 10 °C to 30 °C



6.4.6 Control unit component

See Fig. 701 and Fig. 903, Item 3



Procedure	Testing and measuring equipment	Visual
<p>Visual inspection</p> <p>Conduct function test with the reference unit, mount the control unit to be tested in the reference heater and conduct the function test again</p>	<ul style="list-style-type: none"> - Heater test bench - PC (personal computer) - Webasto Diagnosis Adapter - Reference heater 	

6.4.7 Heater component

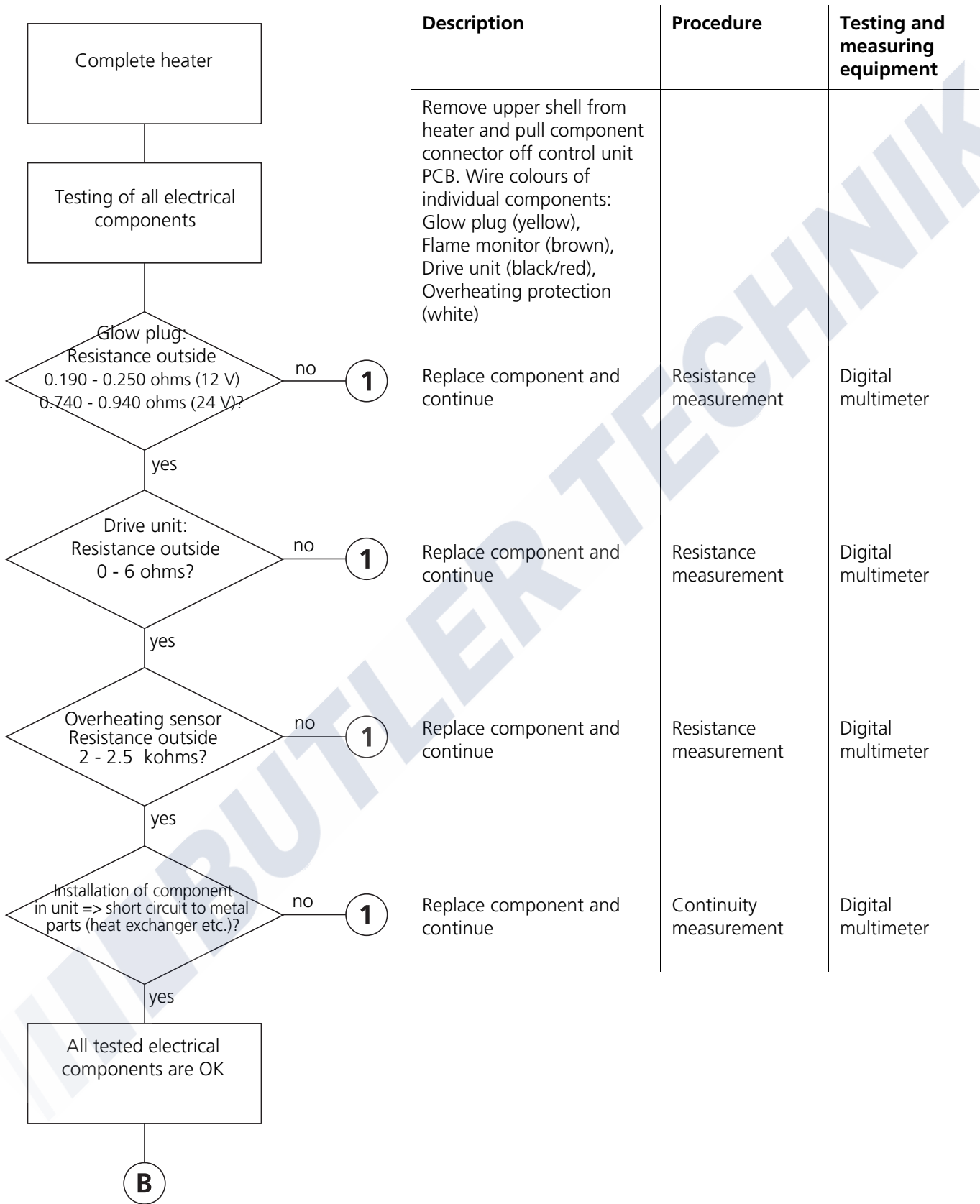

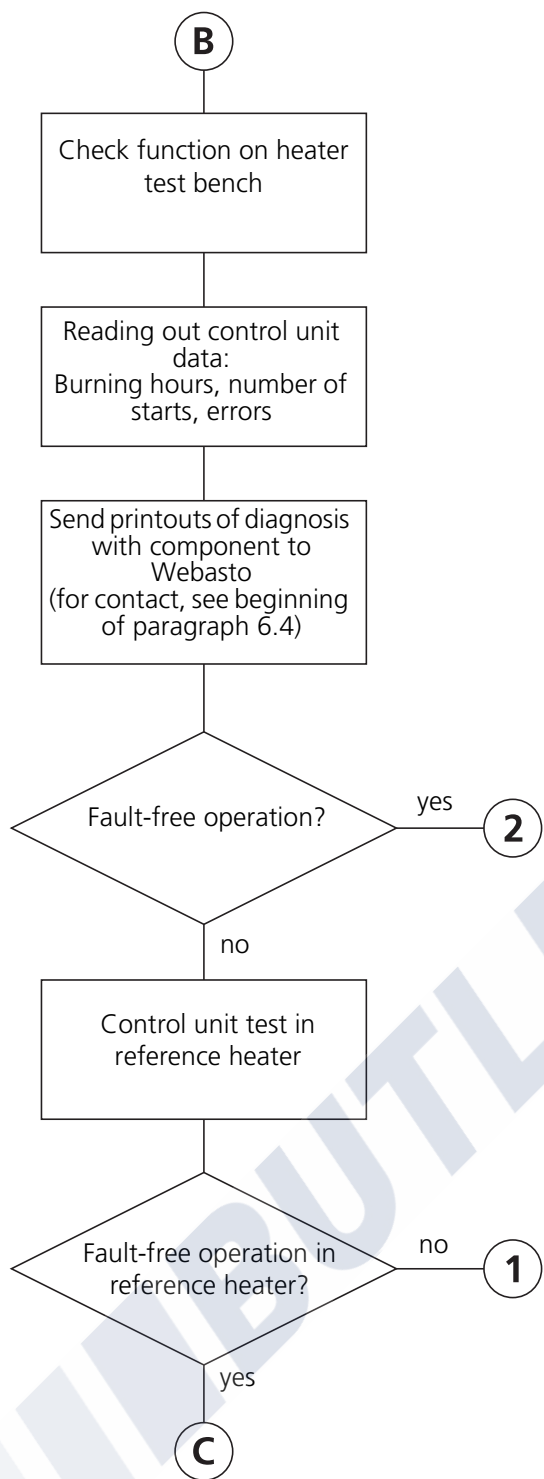

Description	Procedure	Testing and measuring equipment
	Function test	<ul style="list-style-type: none"> - Heater test bench - CO₂ measuring unit - PC (personal computer) - Webasto Diagnosis Adapter - Reference heater
	Function test	

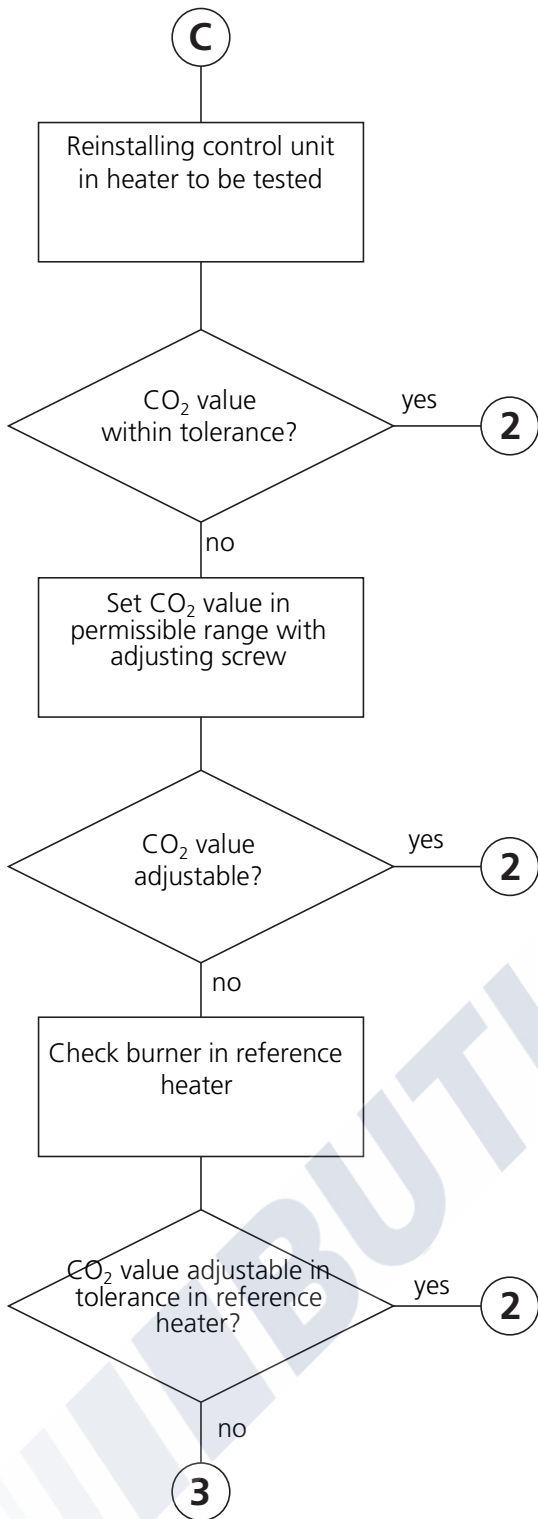

Description

Procedure

Testing and measuring equipment

Function test

CO₂ measurement

Conduct function test with reference heater. Set reference unit to nominal CO₂ value locally after 5 minutes of full-load operation in accordance with graphic, install burner to be tested in reference unit and measure CO₂ value after 5 minutes of full-load operation

- Heater test bench
- CO₂ measuring unit
- PC (personal computer)
- Webasto Diagnosis Adapter
- Reference heater

7 Circuit diagrams

7.1 General

The Air Top Evo 3900 and Air Top Evo 5500 heater units can be operated with the heater control (setpoint generator/switch), a combination timer or the MC04/05 heater control.

The circuit diagrams (Fig. 702 to Fig. 708) show the possible circuits for 12 or 24 Volt with

- Control element and vehicle blower
- ADR operation with control element
- Combination timer and vehicle blower
- Combination timer and electrical battery isolation switch
- Control Panel MC04/05 and vehicle blower
- "Master heater unit" with controls
- "Slave heater unit"

Fig. 701 shows the plug assignment on the control unit.

Fig. 709 shows the schematic connection of the combination timer.

Fig. 710 shows the schematic connection of the Control Panel MC04/05.

See Paragraph 7.2 for the legend of the wiring diagrams.

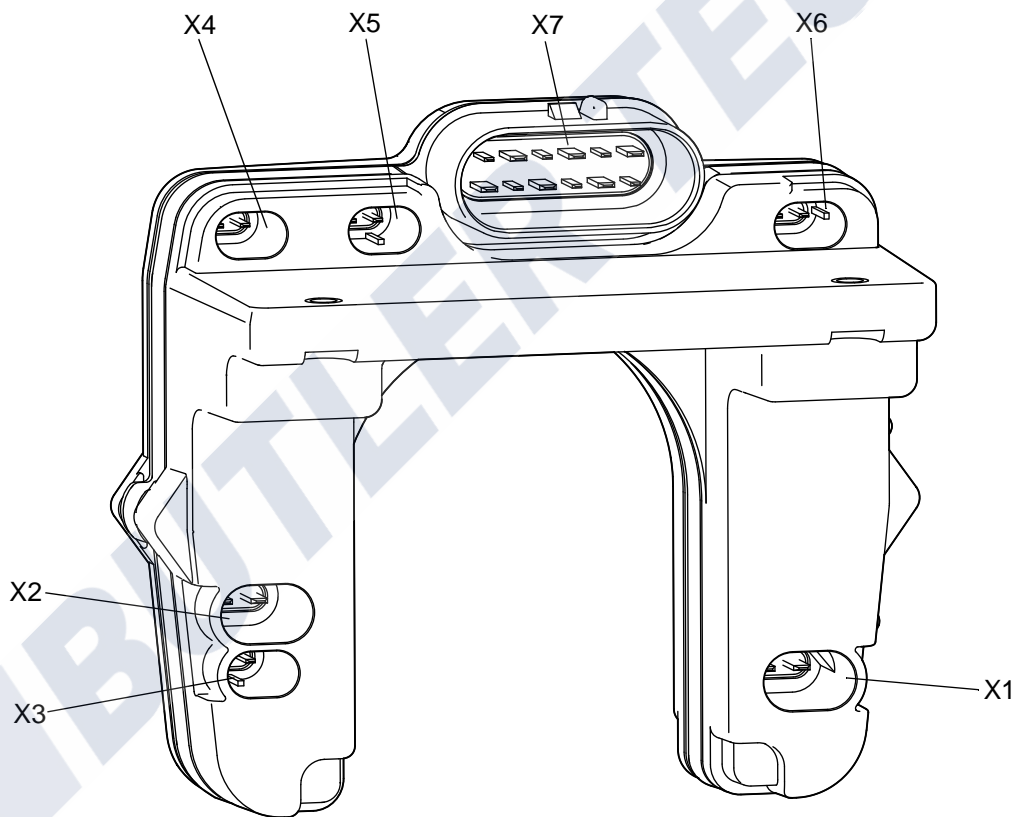

- X1 = Combustion and hot air blower connection
- X2 = Glow plug / Flame sensor connection
- X3 = Overheating sensor connection
- X4 = Metering pump connection
- X5 = External temperature sensor or terminating resistor connection
- X6 = D+ and auxiliary drive unit connection
- X7 = Heater wiring harness connection

Fig. 701 Plug assignment

7 Circuit diagrams

Air Top Evo 3900/5500

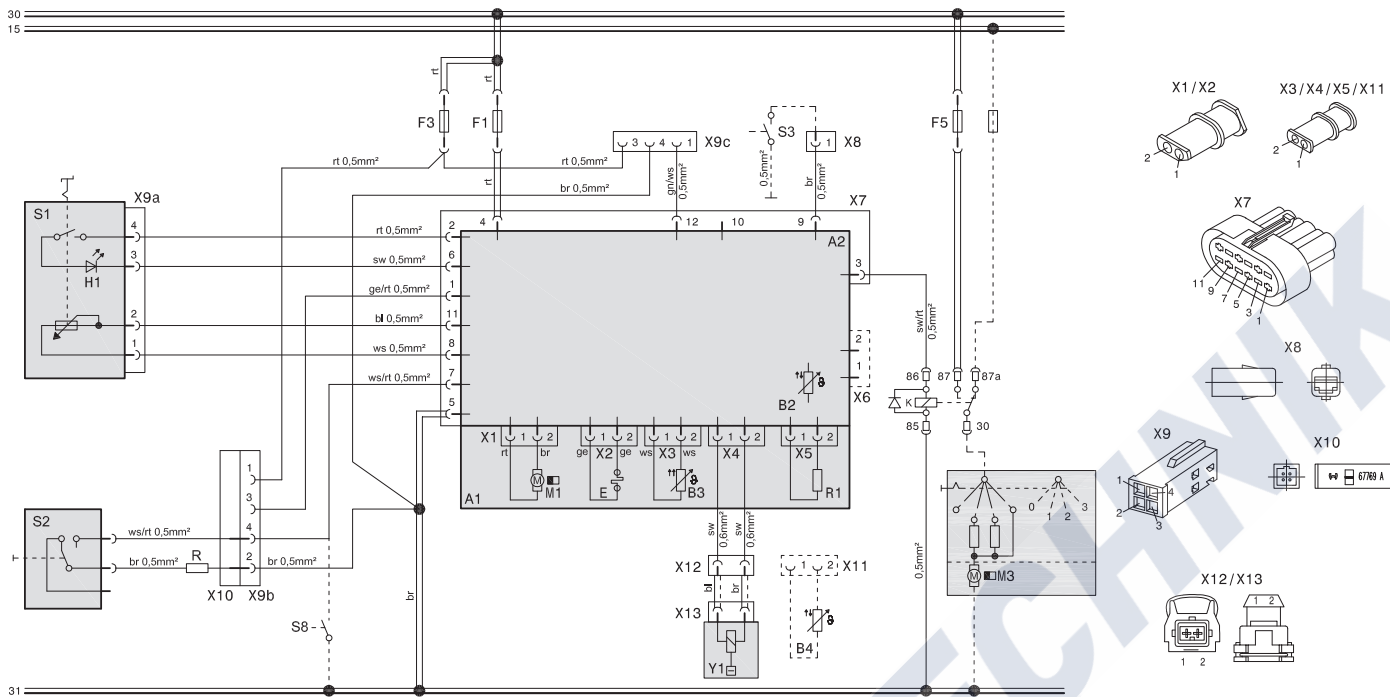

Fig. 702 System circuit diagram 12V/24V with control element and vehicle blower

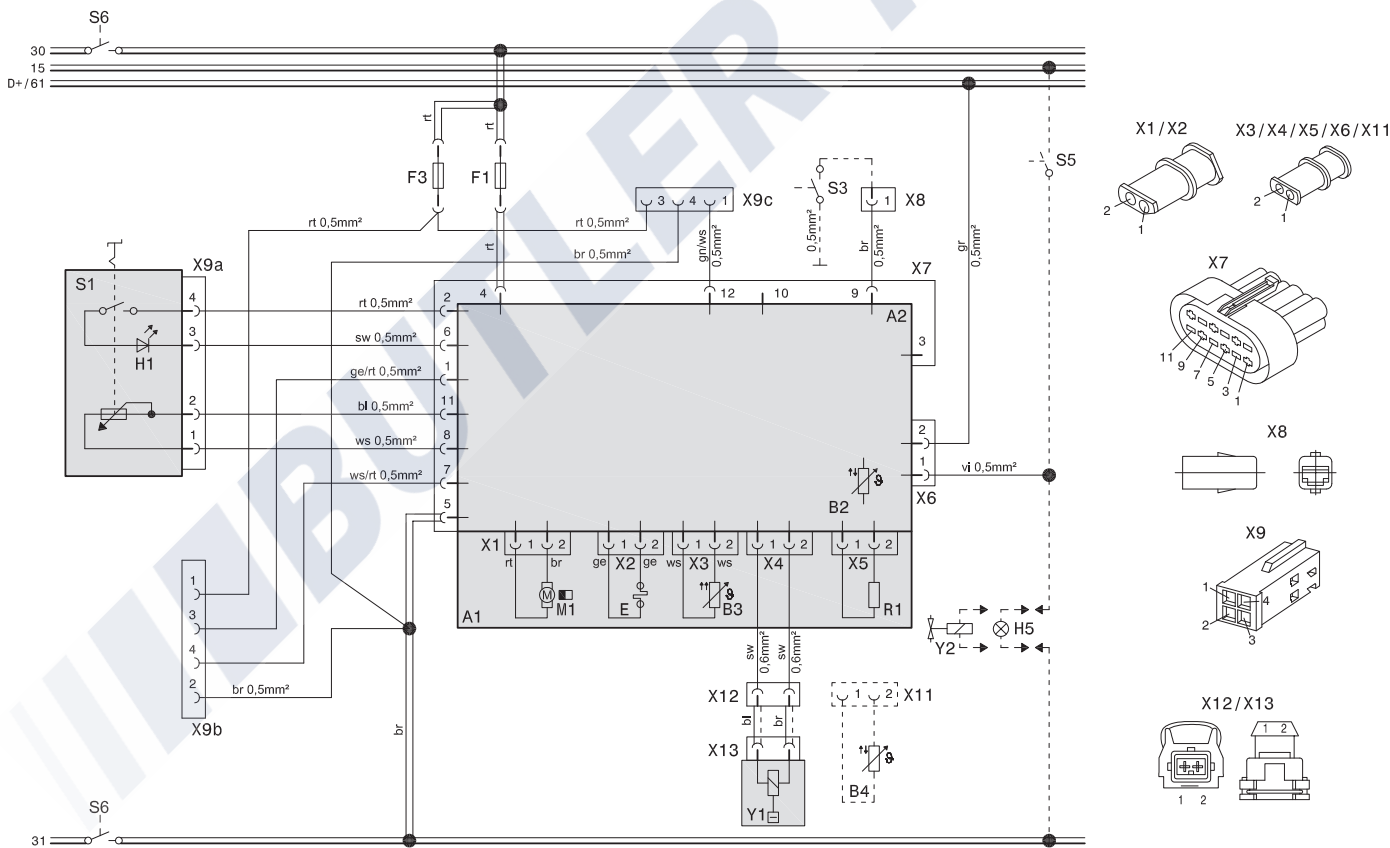

Fig. 703 System circuit diagram 24V ADR operation with control element

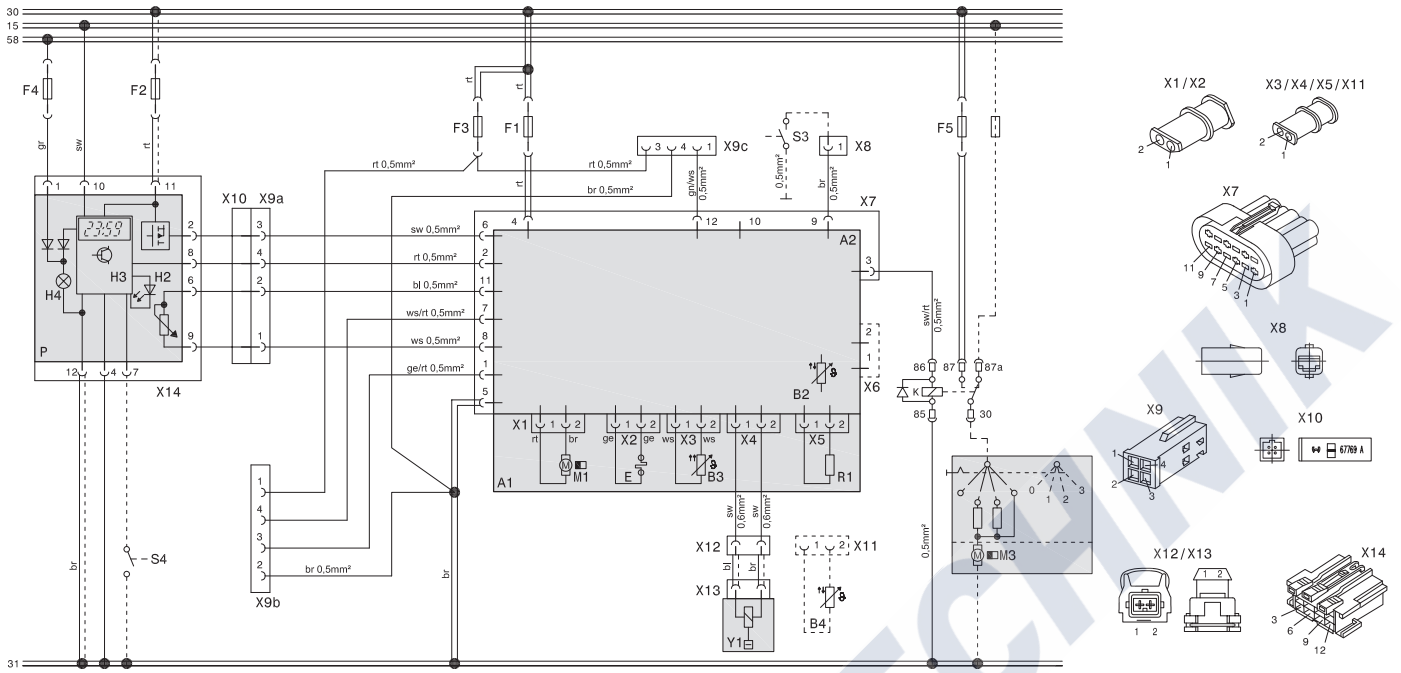

Fig. 704 System circuit diagram 12V/24V with combination timer and vehicle blower

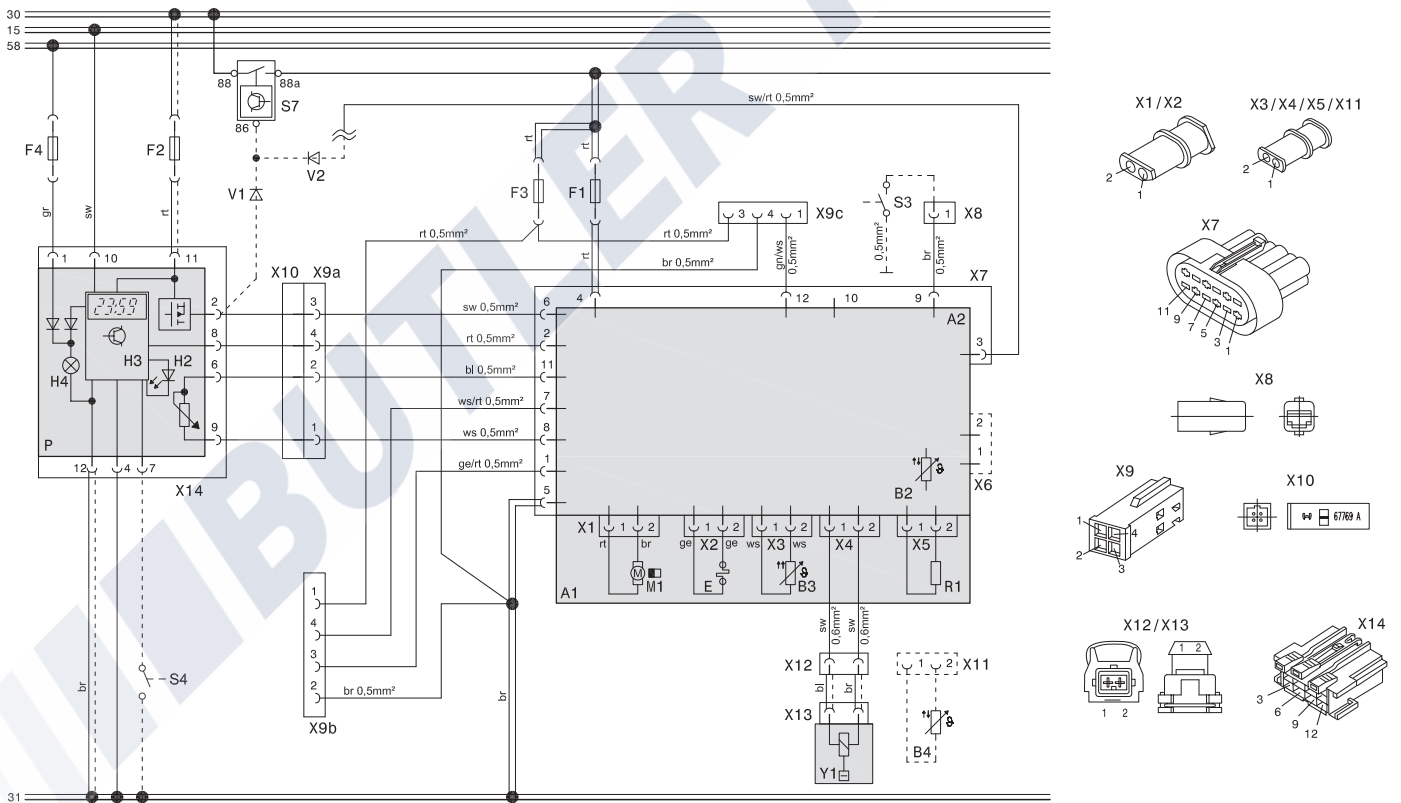

Fig. 705 System circuit diagram (diesel) 12V/24V with combination timer and electrical battery isolation switch

7 Circuit diagrams

Air Top Evo 3900/5500

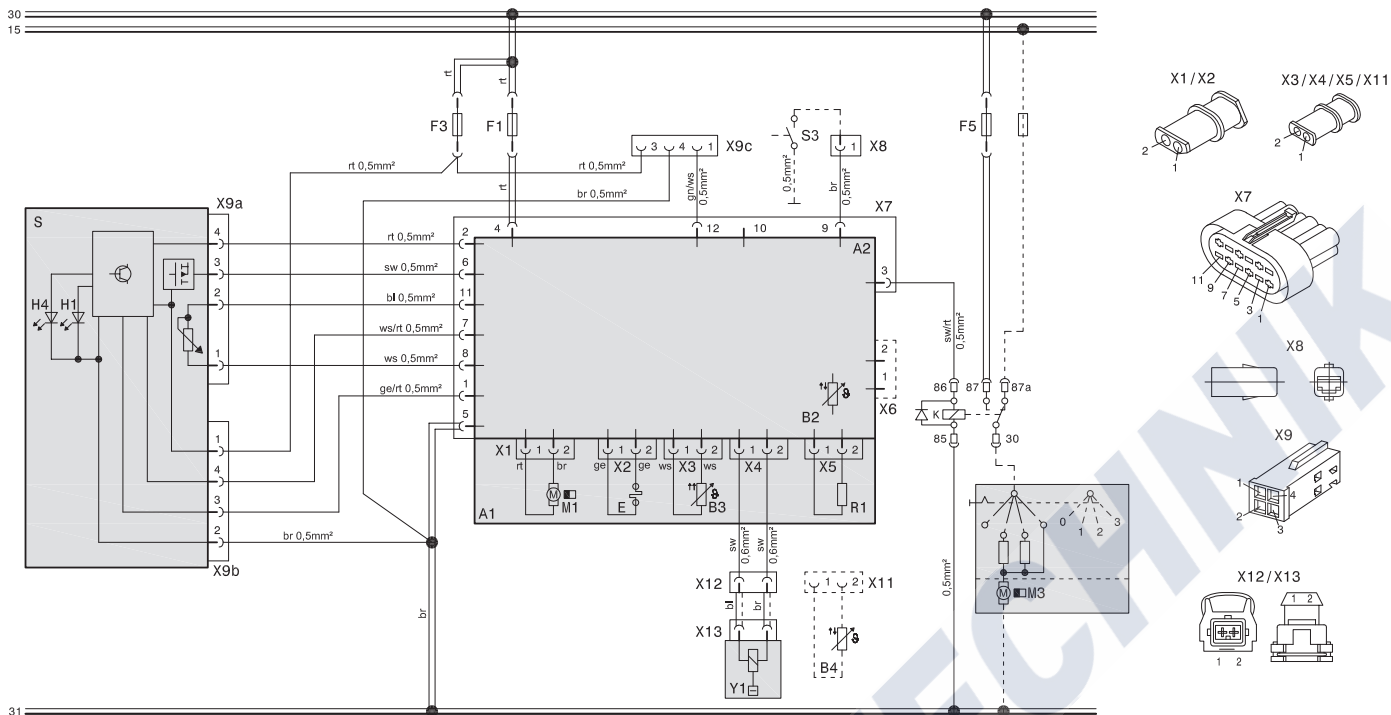

Fig. 706 System circuit diagram (diesel) 12V/24V with Control Panel MC04/05 and vehicle blower

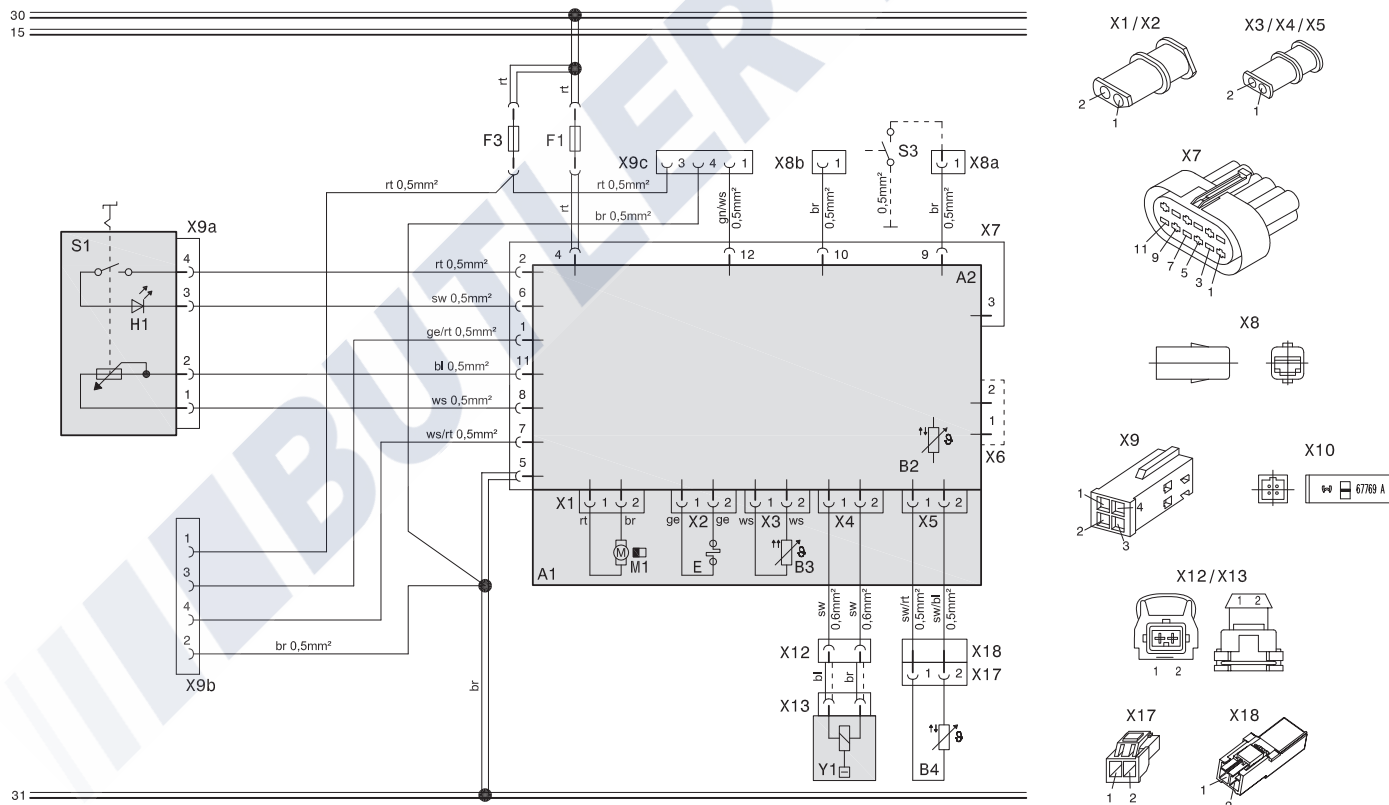

Fig. 707 System wiring diagram Air Top Evo 3900 / 5500 AM "Master heater unit", 12V/24V Diesel with controls

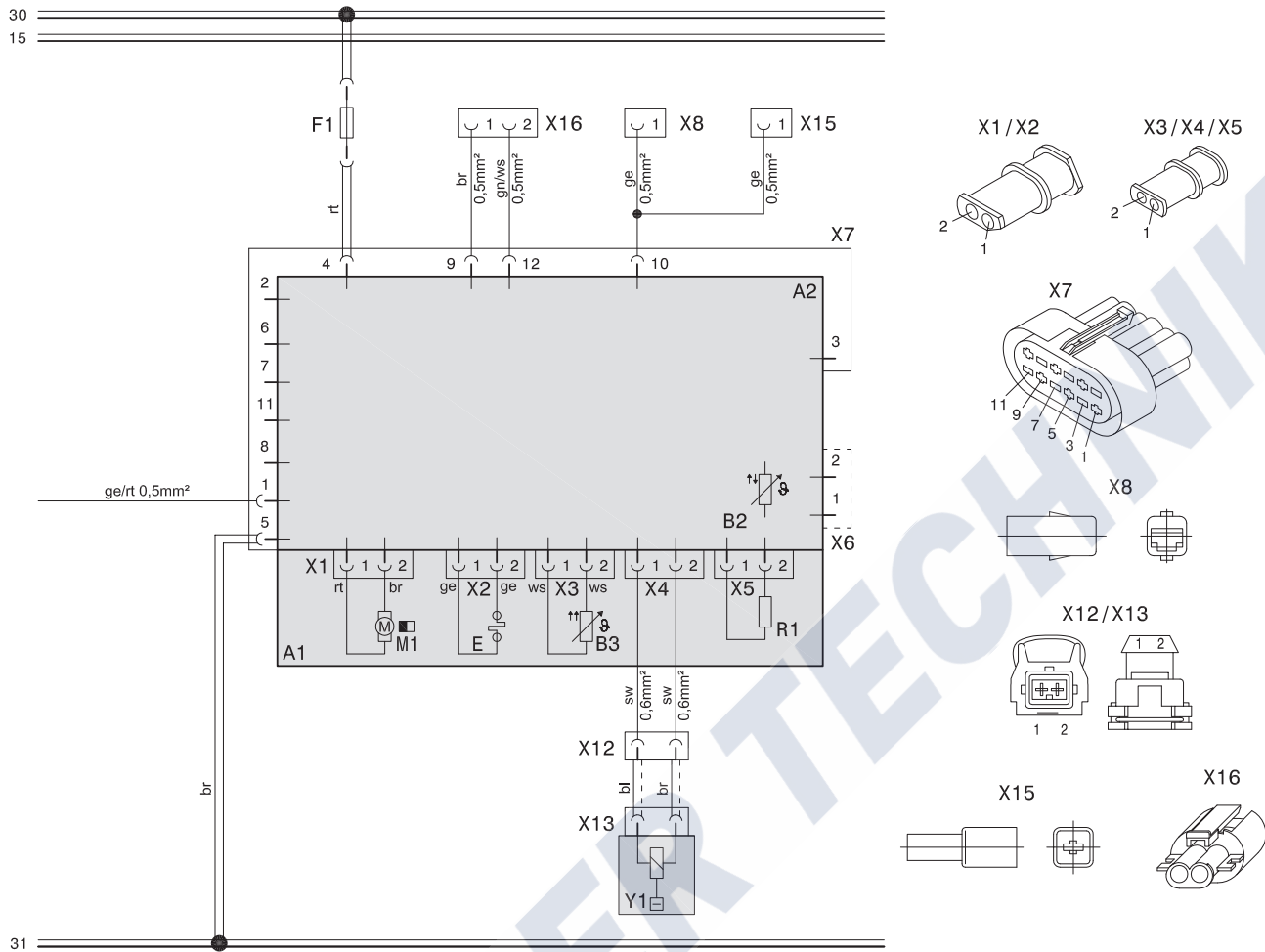

Fig. 708 System wiring diagram Air Top Evo 3900 / 5500 AM "Slave heater unit", 12V/24V Diesel

Combination timer 1531

black: Terminal 15

red: Terminal 30

grey: Terminal 58

brown: Terminal 31

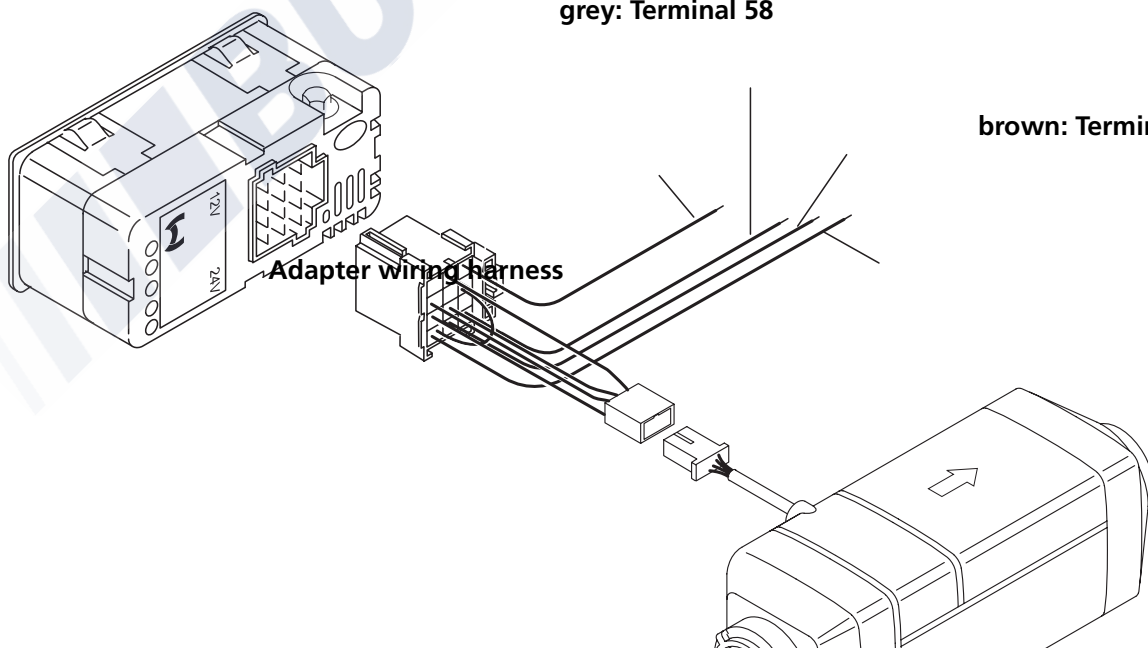

Fig. 709 Schematic connection of the combination timer

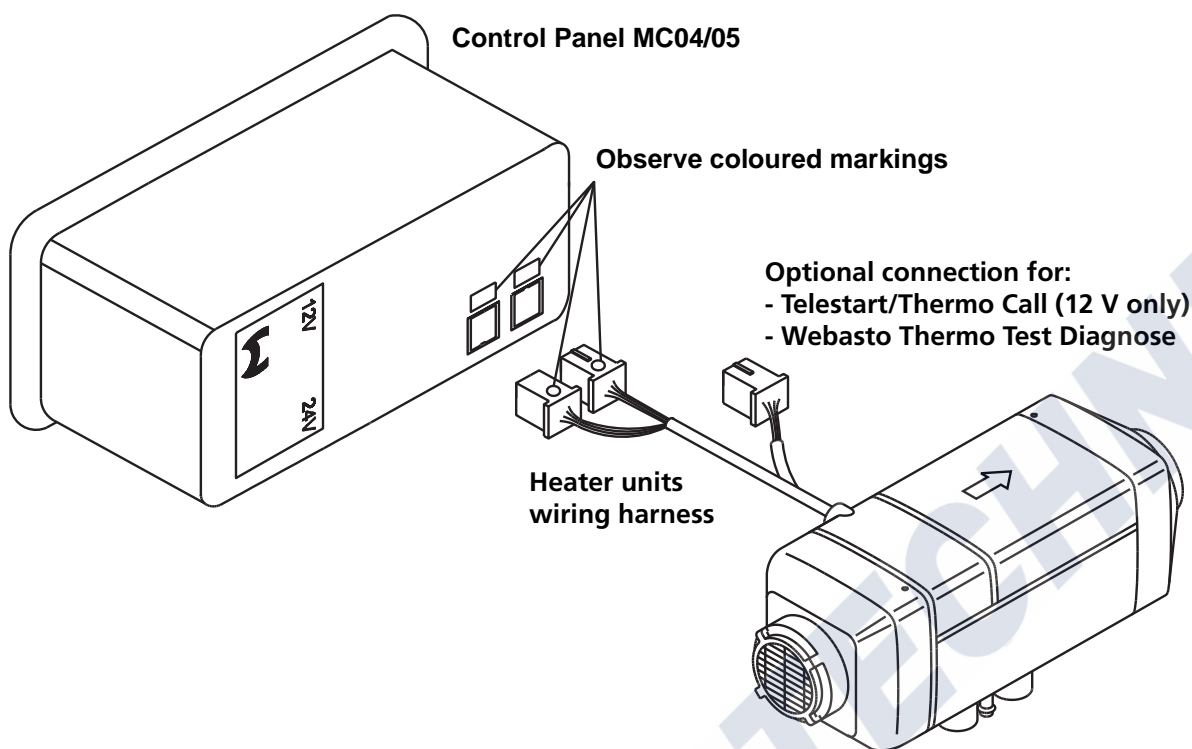

Fig. 710 Schematic connection of the Control Panel MC04/05

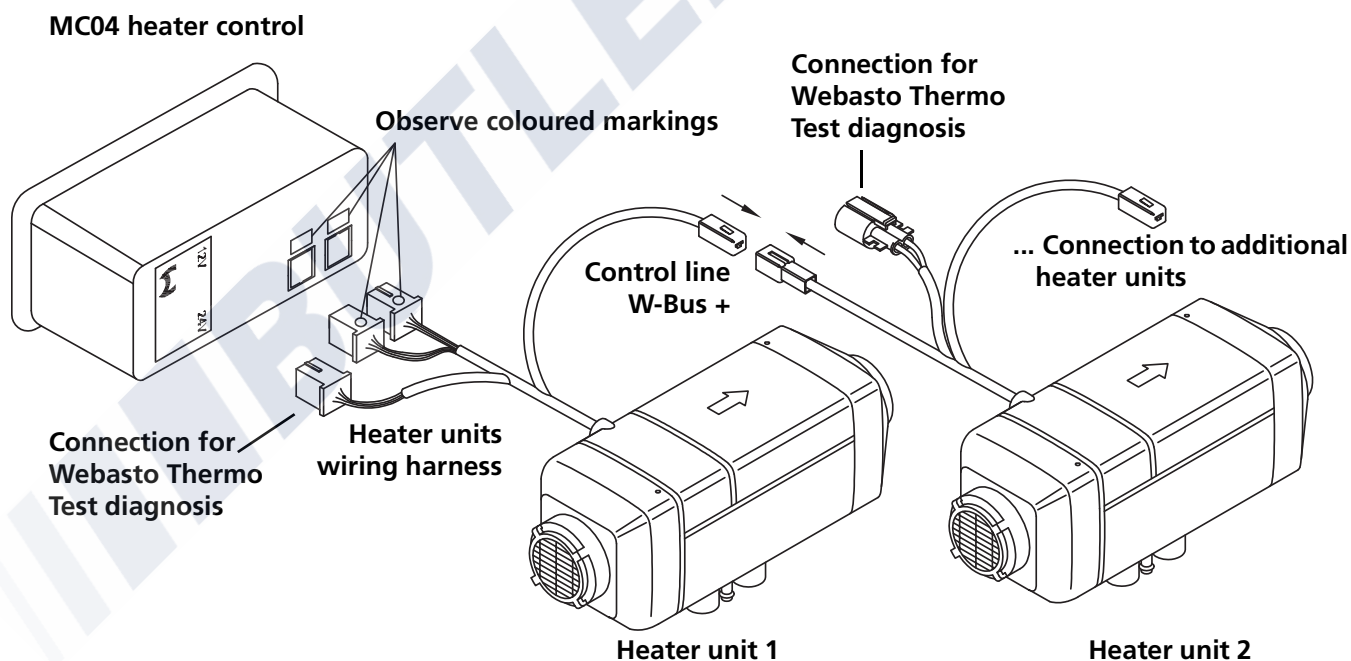

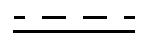

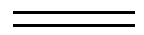



Fig. 711 Connection diagram of Air Top Evo 3900/5500 AM (connection of combination timer 1531 and setpoint generator possible)

7.2 Legend for circuit diagrams

Cable cross-sections		
	< 7.5 m	7.5 - 15 m
	0.75 mm ²	1.0 mm ²
	1.0 mm ²	1.5 mm ²
	1.5 mm ²	2.5 mm ²
	2.5 mm ²	4.0 mm ²
	4.0 mm ²	6.0 mm ²

Cable colours	
bl	blue
br	brown
ge	yellow
gn	green
gr	grey
or	orange
rt	red
sw	black
vi	violet
ws	white

Item	Description	Comment
A1	Heater	Air Top Evo 3900/5500
A2	Control unit	Control unit 1580
B2	Temperature sensor	Internal
B3	Overheating sensor	Overheating guard
B4	Temperature sensor	External
E	Glow plug / Flame monitor	
F1	Fuse 15 A (24 V) or 20 A (12 V)	Flat fuse SAE J 1284
F2	Fuse 4 A	Blade fuse SAE J 1284 not contained in wiring harness
F3	Fuse 1 A	Flat fuse SAE J 1284
F4	Fuse 4 A	Blade fuse SAE J 1284 not contained in wiring harness
F5	Fuse	Value in [A] to be selected depending on line cross-section
H1	LED green (in item S1)	Indicator
H2	LED red (in item P)	Light in immediate heat button, ready indicator, switch-on indicator
H3	Heating symbol in the display (in item P)	Indicator
H4	Light bulb/LED (in item P and S)	Display and button lighting
H5	Light bulb/LED	Switch-on indicator pumping device
K	Relay with free-wheeling diode	for vehicle fan
M1	Motor	Combustion and hot air fan
M3	Motor	Vehicle fan
P	Combination timer (1531)	Timer and setpoint generator
R	Resistor	In adapter wiring harness
R1	Resistor 620 Ω	With internal temperature sensor only

Item	Description	Comment
S	Control Panel MC04/05	On/Off switch, setpoint generator and selector switch for additional functions
S1	Basic heater control	On/Off switch and setpoint generator
S2	Switch	Ventilation
S3	Switch	CO ₂ setting
S4	Push button	External instant heat button
S5	Switch	Pumping devices/ auxiliary drive
S6	Switch, single or two-pin	Isolation switch
S7	Battery isolation switch	Electronically controlled isolation switch
S8	Switch	Boost (e.g. door contact on ambulance)
X1-X7	Plug connector	on item A2
X8a	Plug connector	to item S3
X8b	Plug connector	Connection of additional heater units via serial bus interface
X9a	Plug connector	on item S or S1
X9b	Plug connector	on item S or S2
X9c	Plug connector	W bus, optional connection of Telestart (12 V) or Thermo Call
X10-X12	Plug connector	
X13	Plug connector	to item Y1
X14	Plug connector	to item P
X15	Plug connector	Connection of additional heater units via serial bus interface
X16	Plug connector	W bus
X17-X18	Plug connector	
Y1	Metering pump	
Y2	Solenoid valve/pump	Pumping devices/ auxiliary drive

BUTLER TECHNIK

8 Servicing work

8.1 General

This section describes the servicing work that can be carried out on the heater when it is installed.

8.2 Work on the heater

Disconnect the main power cable from the vehicle's battery before carrying out any work on the heater. The main battery power must not be disconnected whilst the heater is operating or slowing down as a result of the risk of the heater overheating and the overheating guard thus being tripped.

If you wish to carry out extensive repair work on the heater, it may be a good idea to remove it completely.

Refer to the relevant installation instructions and the installation proposal for the heater for the specific vehicle for repairs that necessitate the installation position being changed.

8.3 Work on the vehicle

IMPORTANT

A temperature of 85 °C must not be exceeded in the vicinity of the heater in any circumstances (for example when competing painting work on the vehicle).

8.4 Heater trial

WARNING

The heater must not be operated in enclosed areas such as garages and workshops without an emissions extraction system, even if you use the timer.

IMPORTANT

The heater must not be operated without the cover for the control unit as this will cause it to overheat.

8.5 Servicing work

NOTE

To prevent mechanical parts seizing, the heater should be operated for approx. 10 minutes every four weeks.

The heater requires no servicing. However, it should be checked at regular intervals, at the latest at start of the heating period (the time after which the heater will be used due to adverse weather conditions) by Webasto-trained personnel.

After 3,000 operating hours a flash code (flashing pulses at one-second intervals) are output with the operation indicator. This code indicates the need for maintenance/servicing of the heater to the user. The service signal is output for 10 seconds during each heater unit start-up and can be reset with the Webasto diagnosis by pulling the fuse or with "Delete fault".

The following servicing work is to be carried out to maintain the functional reliability of the heater:

- Check the hot air inlet and outlet for dirt and foreign bodies. (Dirty or blocked hot air lines may cause overheating.)
- Clean the exterior of the heater (avoid the ingress of water).
- Check the electrical connections for contact corrosion and to ensure that they are secure.
- Check the exhaust and combustion air lines for signs of damage and to ensure that they are clear.
- Replace the fuel filter if there is one.
- Check the fuel line and filter for leaks.

8.6 Visual inspections and installation instructions

8.6.1 Hot air system

IMPORTANT

The integration of the heater into the vehicle's own air system is not permitted as a result of the high pressure in the vehicle's system.

Inside the control unit there is a temperature sensor, which operates the heater in the appropriate heat output range in conjunction with the control element depending on the intake temperatures and the position of the setpoint generator. The heat output is set so that after the selected interior temperature has been reached quickly, it is then kept at this selected value.

Alternatively the Air Top Evo 3900/5500 heaters can be operated with an external temperature sensor (see 9.1.2).

NOTE

Only materials that can permanently withstand temperatures of at least 130 °C may be used for the hot air line.

Maximum pressure drop between the inlet and outlet side of the hot air line:

Air Top Evo 3900	2.0 hPa
Air Top Evo 5500	3.0 hPa

1 hPa corresponds to 1 mbar corresponds to 10 mm H₂O (water column).

If this value is exceeded the heat output may be reduced as a result of the hot air outlet temperature control.

8 Servicing work

Air Top Evo 3900/5500

The heater can be used with grills on the air inlet and outlet side if it is used in an air circulation system. Do not short circuit the current of hot air.

Minimum internal diameter of the main section of hot air line:

80 mm for the Air Top Evo 3900
90 mm for the Air Top Evo 5500

The hot air hose must be secured at its connection points.

IMPORTANT

In vehicles used to transport people, the air outlet opening is to be directed in such a way that it is at least 20 cm away from all body parts.

The heaters check the internal temperature rise automatically each time they are switched on. If this is above the specified limits, the start is cancelled and error messages F10 is displayed. To ensure that the heater functions stably, the flow resistance of the connected hot air system must be reduced.

If a filter is used for the hot air, it must have the following properties:

- The current of air must not carry any inflammable and/or harmful fibres or particles into the heater or the interior of the vehicle.
- The filter material must be able to withstand temperatures of at least 60 °C
- The filter must be resistant to all the substances that may be drawn in with the hot air (for example moisture, salt, fuel vapours, etc.).
- The resistance of the filter must be taken into consideration when designing the hot air system

8.6.2 Fuel supply

The fuel is taken from the vehicle fuel tank or from a separate fuel tank. The values for the maximum pressure at the fuel extraction point are shown in Figure Fig. 801.

Permissible fuel inflow height H [m]	At max. perm. pressure [bar] in fuel line
0.00	0.20
1.00	0.11
2.00	0.03
Maximum fuel intake height S [m]	At max. perm. negative pressure [bar] in the fuel tank
0.00	-0.10
0.50	-0.06
1.00	-0.02

8.6.2.1 Fuel extraction.

Vehicles with diesel engines

The fuel must be taken from the vehicle fuel tank or from a separate tank (see Fig. 802, Fig. 803 or Fig. 804). This separate fuel pickup precludes any effect of pressure.

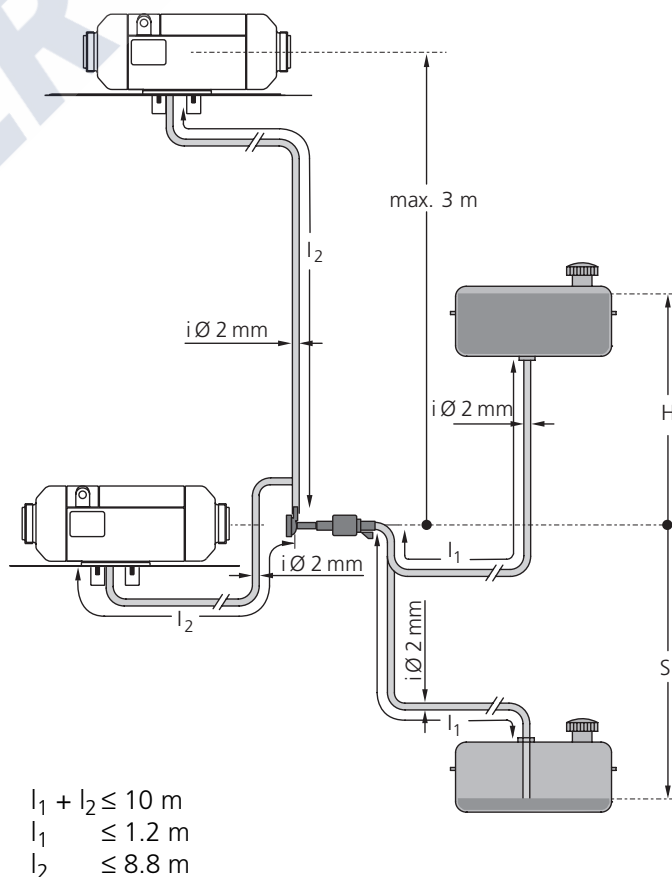

Fig. 801 Fuel supply

Vehicles with carburettor engines

The fuel may only be extracted on cars using the special Webasto fuel extractor (for example Part No. 470 910) as close to the tank as possible. The connect may be made in either the supply or return line, in which case the return line must lead almost to the base of the tank. If this is not the case the return line may be extended.

The fuel extractor must be fitted in such a way that any air or gas bubbles are automatically discharged towards the tank.

The fuel extractor should not be located near the engine, as gas bubbles may form in the lines on account of heat radiated from the engine. This may cause problems during combustion.

Vehicles with injection engines

When installing the heater in a vehicle with fuel injection system, it is important to establish whether the vehicles fuel pump is located inside or outside the tank.

If the fuel pump is located inside the tank, fuel can only be extracted from the return line using the Webasto fuel extractor (for example Part No. 470 910), in which case it must be ensured that the return line continues almost to the bottom of the tank. If this is not the case Webasto fuel extractor (see Fig. 802, Fig. 803 or Fig. 804) may be used.

If the fuel pump is installed outside the tank, the fuel connection may also be made between the tank and the fuel pump, again using only the Webasto fuel extractor (for example Part No. 470 910).

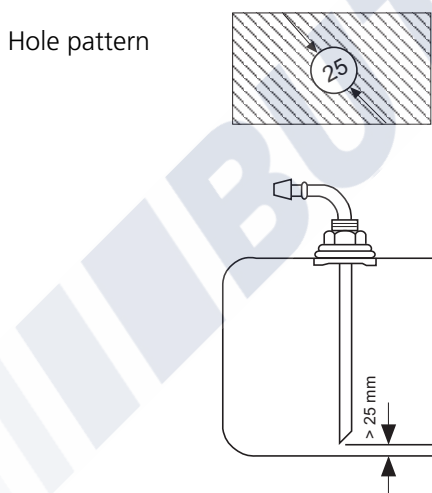

NOTE

Only use a tank extractor with metal fuel tanks

Fig. 802 Webasto tank connector

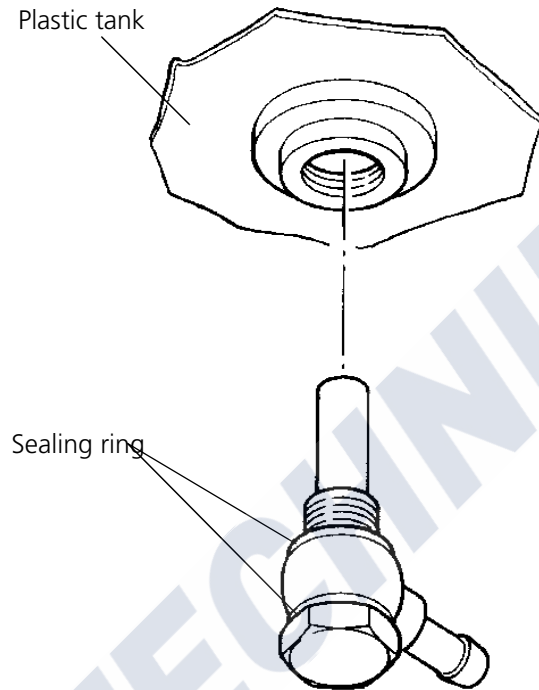
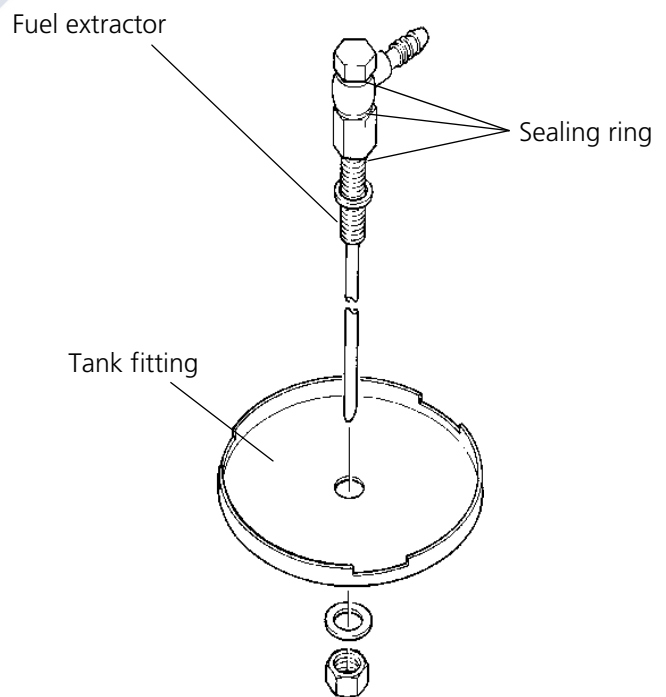

Fig. 803 Fuel extractor from the plastic tank (extraction through tank drain screw)



NOTE

The fitting must be made from metal!

Fig. 804 Fuel extractor from the plastic tank (extraction through tank fitting)

8.6.2.2 Fuel lines

Only steel, copper and plastic lines of plasticised, light and temperature-stabilised PA11 or PA12 (e.g. Mecanyl RWTL) pursuant to DIN 73378 may be used for the fuel lines. Since the lines cannot always be routed with a constant rising gradient, the internal diameter must not be allowed to exceed a certain size. Air or gas bubbles will accumulate in lines with an internal diameter of more than 4 mm and these will cause malfunctions if the lines sag or are routed downwards. The diameters specified in Fig. 801 will ensure that bubbles do not form.

The lines should not be routed downwards from the metering pump to the heater.

Unsupported fuel lines must be secured to prevent them sagging. They must be installed in such a way that they cannot be damaged by flying road chippings and **high temperatures** (exhaust line).

The fuel lines must be secure at the connections using hose clips to prevent their slipping.

Connecting two pipes with a hose

The correct procedure for connecting fuel lines with hosing is shown in Fig. 805.

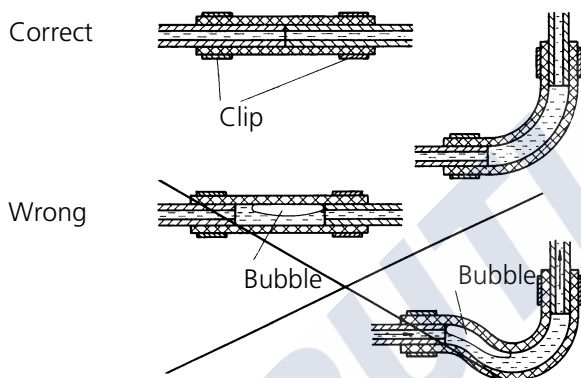
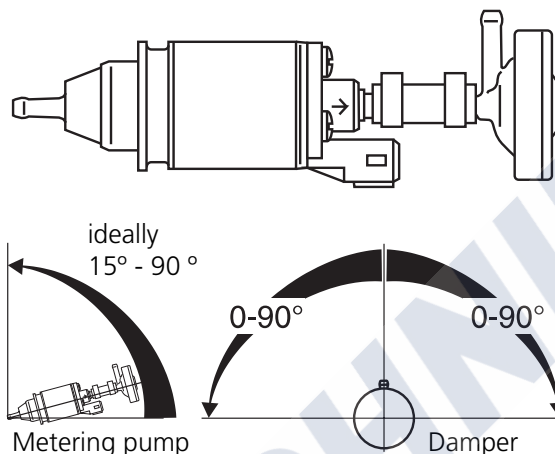

Fig. 805 Pipe/Hose connections

8.6.3 Metering pump

The metering pump is a combined delivery, metering and shutoff system and is subject to specific installation criteria (Fig. 801 and Fig. 806).

Air Top Evo 3900 / Air Top Evo 5500 12 V - petrol DP2 metering pump (with damper)



Air Top Evo 3900 / Air Top Evo 5500 12 V and 24 V - diesel DP 30.2 metering pump

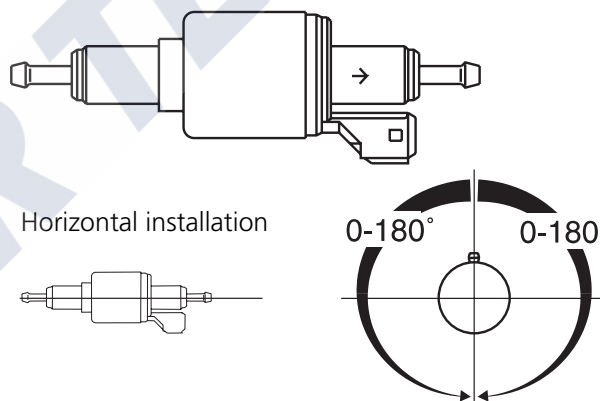

Fig. 806 Metering pump, installation position

8.6.3.1 Installation location

It is advisable to install the metering pump in a cool place. The maximum ambient temperature must not exceed +20 °C at any time during operation. The metering pump and fuel lines must not be installed within range of the radiated heat from hot vehicle parts. A heat shield must be used if necessary.

8.6.3.2 Installation and attachment

The metering pump must be secured with a vibration-dampening mounting. Its installation position is limited as shown in Fig. 806 in order to ensure effective automatic bleeding. As a result of the risk of corrosion, only genuine Webasto parts may be used for the plug connections between the metering pump and the metering pump wiring harness.

8.6.4 Fuel filter

Only a Webasto filter, ident. no. 487 171, is allowed to be used if the fuel is expected to be contaminated. Install vertically if possible, however at least horizontally (check flow direction).

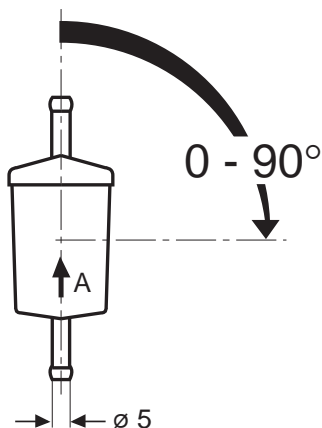

Fig. 807 Fuel filter

8.6.5 Combustion air supply

Under no circumstances may the combustion air be taken from areas occupied by people. The combustion air intake opening must not point in the direction of travel. It must be located so that it cannot become clogged with dirt.

NOTE

The combustion air must be extracted using a combustion air line from a position that is as cool as possible and protected from splashing water for petrol heaters.

If the heater is in a sealed installation box, the combustion air must be drawn in from the outside and the emissions fed to the outside. Pipe passage holes must be made in such a way as to ensure that the ingress of exhaust fumes into the interior of the vehicle should not occur.

If dirty combustion air is expected, a combustion air filter may be fitted.

(Air Top Evo 3900/5500 D only). An intake silencer must be used for an intake hose length of < 0.6 m.

8.6.6 Exhaust pipe

Rigid pipes of unalloyed or alloyed steel with a minimum wall thickness of 1.0 mm or flexible piping of alloyed steel only must be used as exhaust line.

The exhaust pipe must be secured to the heater and exhaust silencer with a pipe clip, Part No. 20 965A.

The exhaust silencer (Fig. 808) should ideally be installed near the heater.

The flow direction is arbitrary.

The heater may also be operated without a silencer.

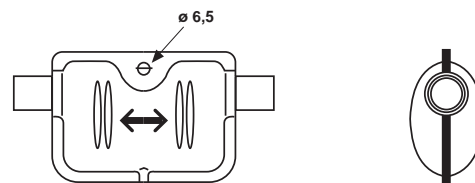

Fig. 808 Exhaust silencer

8.6.7 Combustion air inlet and exhaust lines

NOTE

To prevent damaging the metering pump cable, exhaust line must not be used to extend the combustion air supply line.

Length of the combustion air intake and exhaust lines:
 with silencer: max. 2.0 m
 without silencer: max. 5.0 m

Both lines are to be installed falling away from the heater. If this is not possible, a condensate drain hole with a diameter of 4 mm must be made at its lowest point or a connection element with a condensate drain used.

Internal diameter of the lines:
 Combustion air line: 25 mm
 Exhaust line: 24 mm

NOTE

If the exhaust line is 2 m or more, insulated exhaust lines must be used (to prevent the temperature falling below the dew point).

Minimum bending radius: 50 mm

Total bends:
 Combustion air line: max. 270°

Exhaust line: max. 270°

An attachment is required no further than 150 mm from the end of the exhaust pipe to ensure that the angle of $90^\circ \pm 10^\circ$ is achieved.

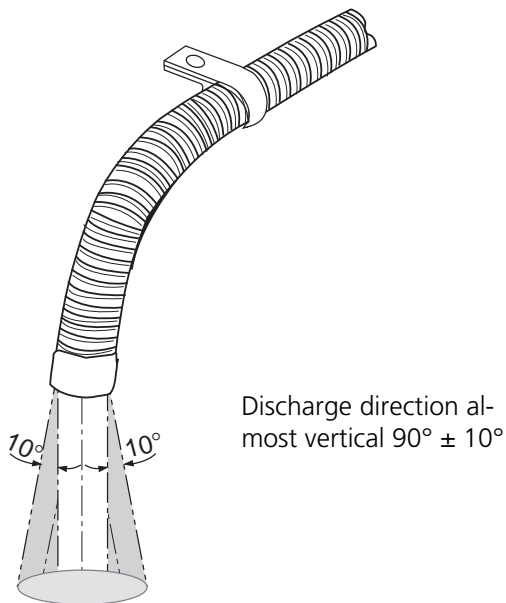

Fig. 809 Exhaust pipe ends, installation position

WARNING

If the exhaust pipe ends is other than as shown in the Fig. 809 it will pose a fire risk.

8.6.8 Electrical connections

8.6.8.1 Heater connection, control element

The electrical connection is to be made as shown in the appropriate circuit diagram (see section 7).

To connect the wiring harness, remove the cover (see 9.2.1.1) on the heater and connect the wiring harness plug to the control unit.

Before using the heater for the first time fit the cover to prevent the illegal escape of hot air (heater overheating).

The wiring harness can be fed out of the left or right side of the heater.

8.6.8.2 Supply voltage connection

Ideally from the vehicle's central electrical system.

An additional blade terminal fuse holder is to be fitted to protect the heater (supplied with the heater). The fuse holder may only be installed in the interior of the vehicle.

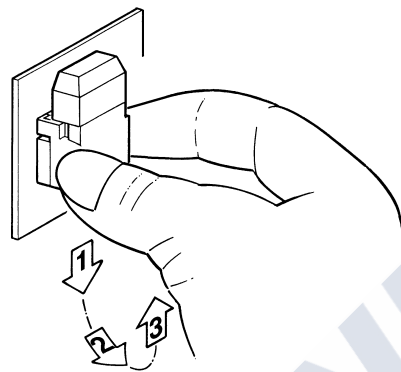

Fig. 810 Remove the fastening plate on the fuse holder

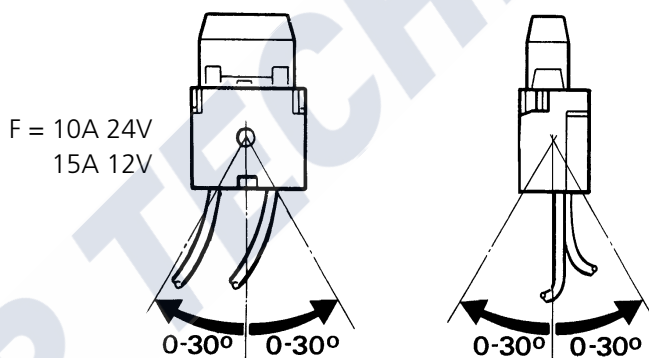

Fig. 811 Fuse holder, installation position

8.6.8.3 Control element connection

The wiring harness is prepared for connection to the control element.

Simply pull on connector housing to unplug the connector (Fig. 813).

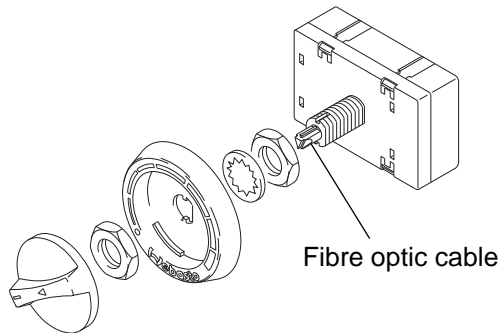

Fig. 812 Control element

NOTE

The fibre optic cable must be in contact with the rotary knob.

NOTE

The connector housing can be locked (self-locking action) by simply pulling on the wiring harness.

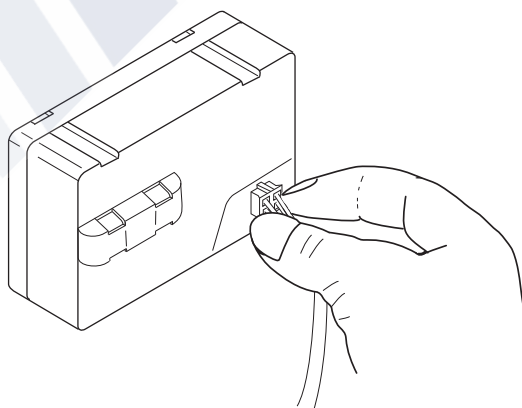
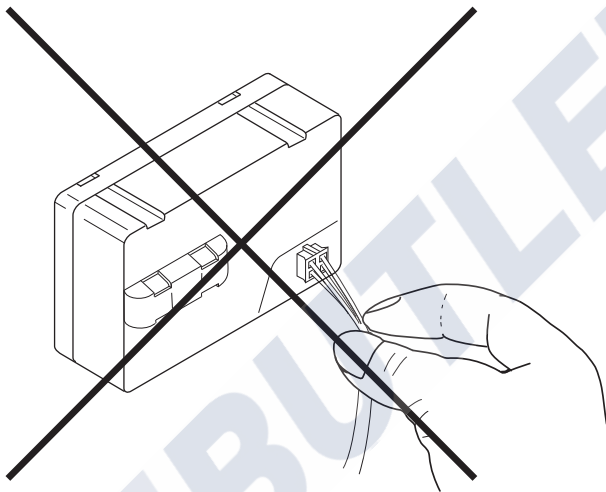
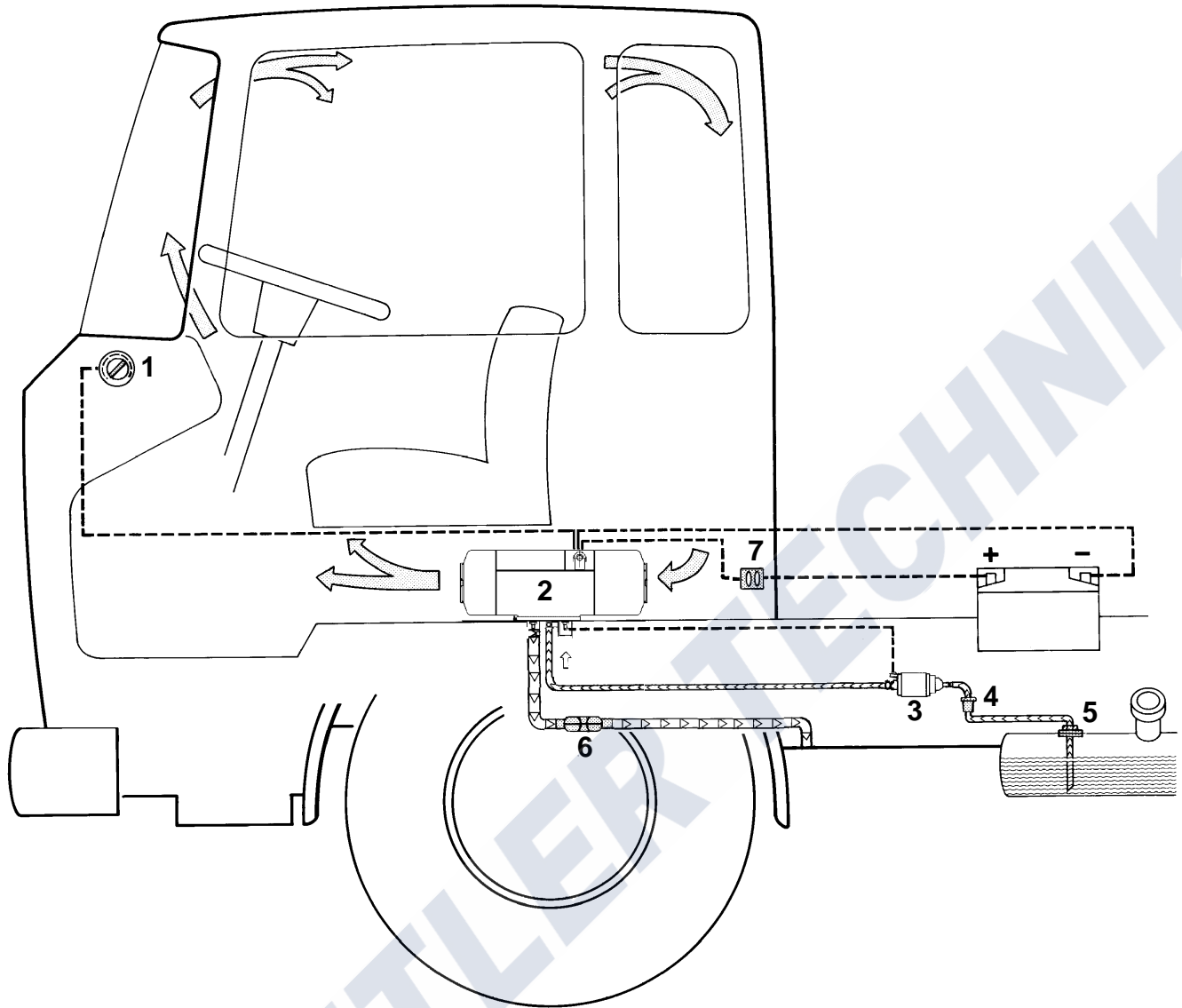

Fig. 813 Disconnect the plug



- 1 Control element
- 2 Heater
- 3 Metering pump
- 4 Fuel filter (accessory)
- 5 Tank connector
- 6 Exhaust silencer
- 7 Fuse

Fig. 814 Installation example for heater in recirculation mode

8.7 Removal and installation

IMPORTANT

When the heater is installed it must not be dismantled.

8.7.1 Heater, removal and installation

8.7.1.1 Removal

1. Disconnect the battery.
2. Pull the cover off the top shell as described in 9.2.1.1
3. Disconnect the wiring harness plug from the control unit.
4. Disconnect the cable to the metering pump at the disconnection point.
5. If necessary disconnect the hot air hose or hoses connection.
6. Disconnect the connection for the combustion air inlet on the heater.
7. Disconnect the connections for the combustion air inlet and exhaust outlet on the heater.
8. Remove four nuts and locking washers from the heater.
9. Remove the heater and discard the seal on the exhaust outlet.

8.7.1.2 Installation

1. Place the heater with a new seal on the exhaust outlet in the installation position and secure it with 4 nuts and locking washers (use only genuine Webasto nuts).
2. Tighten the nuts to 6 +1 Nm.
3. Secure the connection for the combustion air inlet on the heater.
4. Secure the connections for the combustion air inlet and exhaust outlet on the heater.
5. Connect the metering pump cable to the metering pump wiring harness.
6. Connect the wiring harness plug to socket X7 on the control unit.
7. Fit the cover as described in 9.2.2.5 and secure it.
8. If necessary fit the hot air hose or hoses and secure them.
9. Connect the battery.
10. Bleed the fuel supply system.

8.8 Start-up

After you have installed the heater, bleed the fuel supply system carefully.

NOTE

As a result of the low fuel consumption the heater must be switched on several times to fill the fuel line.

Conduct a trial of the heater to check all the connections for leaks and to ensure that they are secure. If the heater suffers a fault during operation, the fault must be located and remedied.

9 Repair

9.1 General

This section describes the repair work that may be carried out on the Air Top 3900/5500 heater after it has been removed from the vehicle.

Any further dismantling will invalidate the warranty. Only use the spare parts from the appropriate spare parts kits for assembling the heater.

9.1.1 Work on stripped down components

IMPORTANT

All sealing elements between the stripped down components and the seal on the exhaust outlet must always be discarded and replaced.

9.1.1.1 Cleaning

- Clean all stripped down components with benzene and then dry them with compressed air.
- Remove all seal residue on the components in full care-fully using a suitable tool.

9.1.1.2 Visual inspection

- Check all components for damage (cracks, deformation, wear, etc.) and fit new ones if necessary.
- Inspect the plugs and cables for corrosion, loose con-tacts, crimping faults, etc. and repair them if necessary.
- Check plug strips for signs of corrosion and contacts to ensure they are secure. Repair them if necessary.

9.1.2 Carrying out modifications

NOTE

The constant development of our heaters is aimed at opti-mising them so as to prevent failures and malfunctions. Generally it is possible to modify heaters that are already in use. We can supply the appropriate modification kits for this purpose.

The following describes modifications that can be carried out without any great effort during standard repair work:

- Installation of an external temperature sensor for better temperature control (see 9.1.2.1).

9.1.2.1 Installation of an external temperature sensor

General

The Air Top Evo 3900 or Air Top Evo 5500 heater can con-trol the required temperature perfectly if its temperature sensor is exposed to the air temperature of the main area of the vehicle.. In certain circumstances, this is not always pos-sible using the temperature sensor integrated in the control unit due to the installation circumstances. In this case per-fect temperature control can be ensured using an external temperature sensor fitted in the appropriate area.

Method

1. Select a suitable position for an external temperature sensor.

NOTE

- The temperature sensor should not be in the direct line of hot air and not close to heat sources (for example the vehicle's own heating system).
 - The sensor is to be installed at medium height in the ve-hicle cabin on surfaces that are as vertical as possible.
 - The installation site should not be exposed to direct sun-light.
 - Do not install the temperature sensor behind curtains or the like.
2. Remove cover and pull terminating resistor (5, Fig. 903) off control unit (connector X5).
 3. Install the external temperature sensor and route the ca-ble to the heater.
 4. Connect the plug on the external temperature to socket X5 on the control unit and fit the cover.
 5. Conduct a trial and check the control properties.

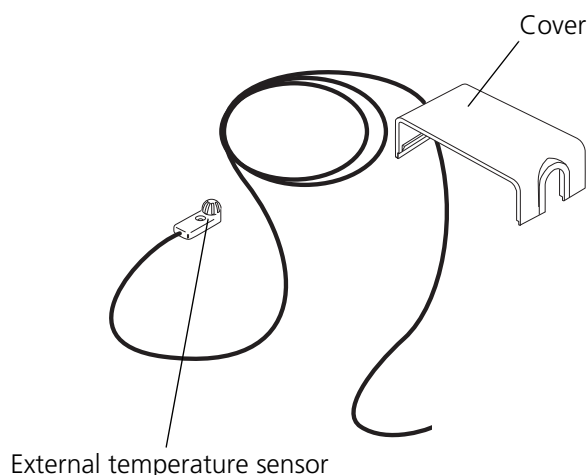

Fig. 901 External temperature sensor

9.2 Dismantling and assembling

9.2.1 Remove the casing parts

9.2.1.1 Cover for electrical connection

The cover (1, Fig. 902) can be carefully levered off using a blunt blade in the areas marked "X".

9.2.1.2 Grill for hot air inlet and outlet

The grill (6, Fig. 902) can be released from its mounting by twisting it and then pulled off forwards.

9.2.1.3 Covers for hot air inlet and outlet

Both covers (3 and 5, Fig. 902) can be released from their mountings and removed by pressing the four detents at the top and bottom using a suitable tool.

9.2.1.4 Top shell

NOTE

The covers for the hot air inlet and outlet must have been removed.

The top shell (2, Fig. 902) can be raised after the covers for the hot air inlet and outlet have been removed.

9.2.1.5 Bottom shell

Remove the seal from the exhaust outlet.

By pulling the bottom shell (4), on both sides gently around areas "Y", you can release the fixing and the shell can be taken off the motor casing. Take off the 4 insulators (7) at the same time.

9.2.2 Fit the casing parts

9.2.2.1 Bottom shell

1. Ensure that the 4 insulators (7) are properly positioned on the heat exchanger.

IMPORTANT

When you fit the bottom shell (4), spread it slightly so that the spacers on the overheating sensor (8, Fig. 903) are not damaged.

2. Expand the bottom shell (4, Fig. 902) slightly at the side and fit it to the heater from underneath until the securing pins on the heater engage in the holes in the shell.
3. Fit a new seal on the exhaust outlet.

9.2.2.2 Top shell

Place the top shell (2, Fig. 902) on the heater and secure it in the grooves in the bottom shell.

9.2.2.3 Cover for hot air inlet and outlet

NOTE

The covers for the hot air inlet and outlet are different. Fit the cover with the larger opening at the front on the hot air fan.

Push on the covers (3 and 5, Fig. 902) until the four securing holes engage properly in the detents on the bottom and top covers.

9.2.2.4 Grill for hot air inlet and outlet

Fit the grills (6, Fig. 902) on the covers for the hot air inlet and outlet and twist them to secure them.

9.2.2.5 Cover for electrical connection

NOTE

The wiring harness is to be guided out to the left or right of the heater to suit the installation situation.

Slide on the cover (1, Fig. 902) until it audibly engages in the top cover.

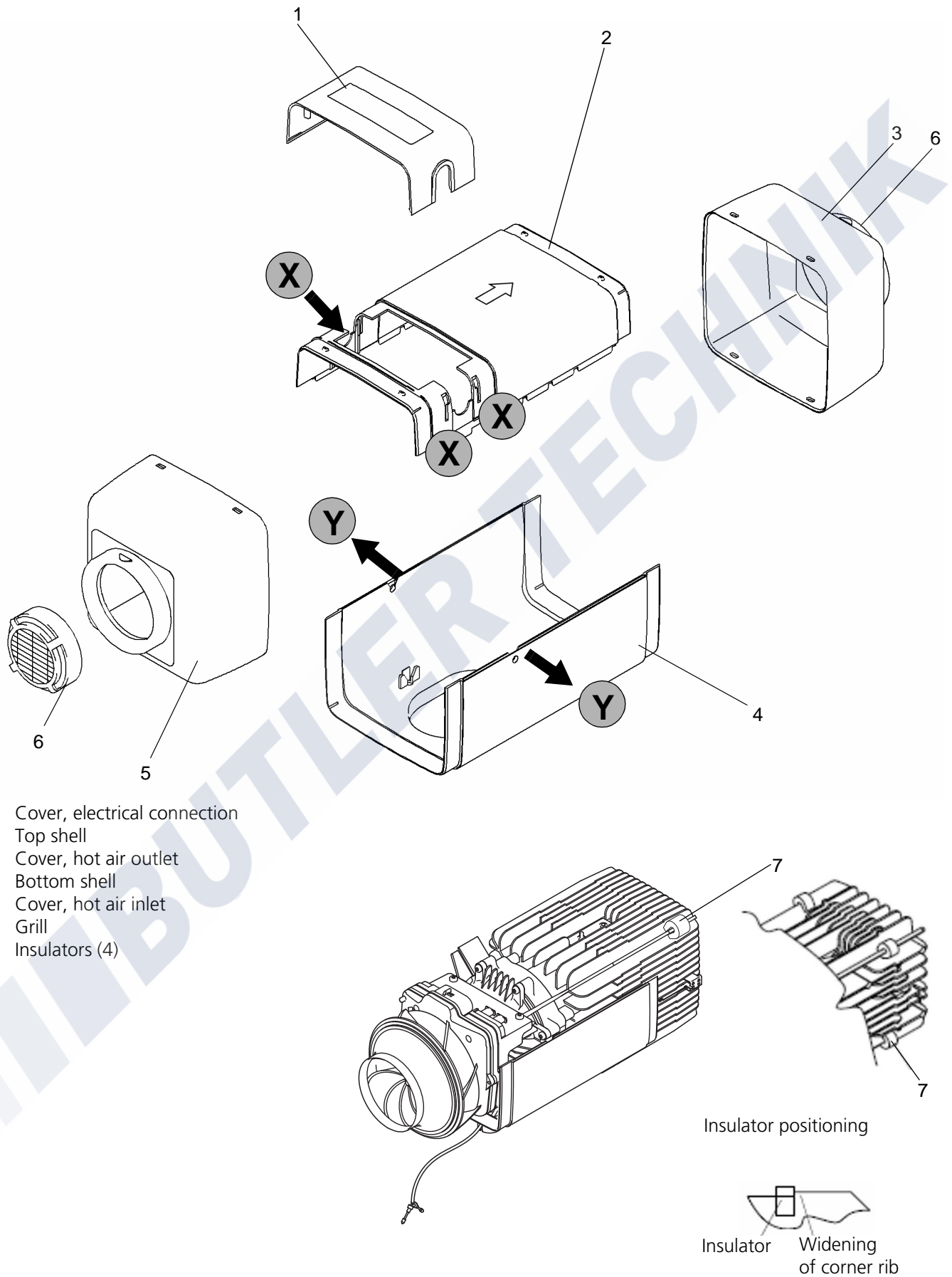

Fig. 902 Remove/fit the casing parts

9.2.3 Change the control unit

9.2.3.1 Removal

1. Remove heater (see 8.7.1.1).
2. Remove casing parts (see 9.2.1).
3. Disconnect plug connections on control unit (3, Fig. 903).
4. Remove screws (4).
5. Slide the control unit (3) towards the hot air fan and remove it upward.
6. Complete the work on stripped down components (see 9.1.1).

NOTE

Do not carry out any repair work to the control unit.

9.2.3.2 Installation

1. Insert control unit (3, Fig. 903) on combustion and hot air fan (1), slide toward fan housing and fasten with screws (4).
2. Tighten the screws (4) to 3.0 ± 0.3 Nm.
3. Insert plug connections on control unit as shown in Fig. 701.
4. Mount casing parts (see 9.2.2).
5. Install heater (see 8.7.1.2)
6. Check the CO₂ setting and adjust it if necessary. (see 6.3)

9.2.4 Change the overheating sensor

9.2.4.1 Removal

1. Remove heater (see 8.7.1.1).
2. Remove casing parts (see 9.2.1).
3. Disconnect plug connection X3 from control unit (3, Fig. 903).
4. Lever overheating sensor (8) out of heat exchanger's ribs using a suitable tool (see Detail A).

IMPORTANT

Do not pull the cables.

5. Remove overheating sensor (8).

9.2.4.2 Installation

1. Conduct resistance measurement on overheating sensor (8, Fig. 903) (see 6.4.5).
2. Position overheating sensor (8) and press it into place by hand.
3. Ensure that overheating sensor is correctly positioned in heat exchanger (7).
4. Connect plug connection X3 to the control unit (3).
5. Mount casing parts (see 9.2.2).
6. Install heater (see 8.7.1.2)

9.2.5 Change combustion and hot air fan (drive unit)

IMPORTANT

Only replace the drive unit (1, Fig. 903) with a drive unit with the same rating data and the same ID No.

NOTE

The drive unit (combustion and hot air fan) can only be completely replaced. It cannot be repaired.

9.2.5.1 Removal

1. Remove heater (see 8.7.1.1).
2. Remove casing parts (see 9.2.1).
3. Remove control unit (see 9.2.3.1).
4. Remove screws (2).
5. Remove the combustion and hot air fan (1) toward front.
6. Remove and discard flat seal (6).
7. Complete work on stripped down components (see 9.1.1).

9.2.5.2 Installation

1. Make sure that sealing surfaces on combustion and hot air fan (1, Fig. 903) and heat exchanger (7) are not damaged.
2. Fit a new flat seal (6) on the flange of the combustion and hot air fan (1).
3. Move combustion and hot air fan (1) into assembled position and fasten with screws (2).
4. Tighten screws to 6.0 ± 0.6 Nm..
5. Install control unit (see 9.2.3.2).
6. Mount casing parts (see 9.2.2).
7. Install heater (see 8.7.1.2)
8. Check the CO₂ setting and adjust it if necessary. (see 6.3)

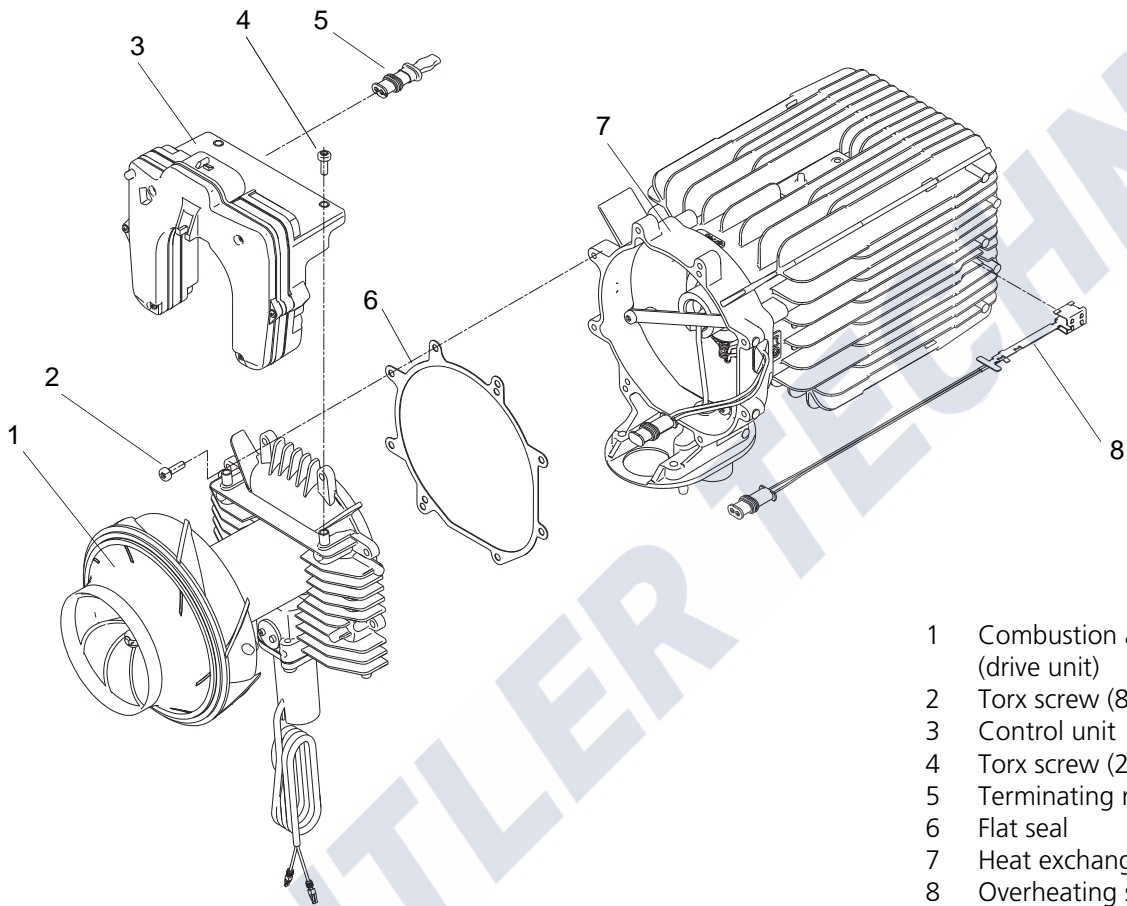

- 1 Combustion and hot air fan (drive unit)
- 2 Torx screw (8)
- 3 Control unit
- 4 Torx screw (2)
- 5 Terminating resistor
- 6 Flat seal
- 7 Heat exchanger
- 8 Overheating sensor

Detail A

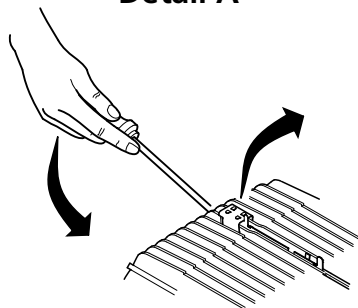

Fig. 903 Change control unit, overheating sensor and combustion and hot air fan (drive unit)

9.2.6 Change burner and glow plug/flame sensor

9.2.6.1 Removal

1. Remove heater (see 8.7.1.1).
2. Remove casing parts (see 9.2.1).
3. Remove control unit (see 9.2.3.1).
4. Remove combustion and hot air fan (see 9.2.5.1).
5. Remove 2 screws (1, Fig. 904) and take off clamping bar (2).
6. Press grommet of glow plug/flame sensor (8) inward out of the heat exchanger casing (6).
7. Press grommet on burner fuel line (3 or 7) inward out of heat exchanger casing (6).
8. Carefully pull burner (3 or 7) out of combustion chamber (4) and take fuel supply line out of heat exchanger casing (6) by turning burner.
9. Remove retaining clip (9) and pull glow plug/flame monitor (8) out of burner (3 or 7).
10. Complete work on stripped down components (see 9.1.1).

9.2.6.2 Installation

1. Guide glow plug/flame monitor (8, Fig. 904) into burner (3 or 7) (cable toward opening for cable grommet) and fasten with retaining clip (9).
2. Guide burner (3 or 7) into heat exchanger (6) against installation direction, turn in installation direction and insert in combustion chamber (4).
3. Move retaining bar (2) in its assembly position and secure it with 2 screws (1).
4. Tighten screws (1) to 4 ± 0.4 Nm.
5. Press grommet on fuel line into heat exchanger (6).
6. Thread the cable for the glow plug/flame sensor (9) through the opening in the heat exchanger casing (6).
7. Press the grommet into the heat exchanger.
Ensure that the glow plug cables do not form a loop in the heat exchanger.
8. Mount combustion and hot air fan (see 9.2.5.2).
9. Install control unit (see 9.2.3.2).
10. Mount casing parts (see 9.2.2).
11. Install heater (see 8.7.1.2)

9.2.7 Change the combustion chamber and the heat exchanger

9.2.7.1 Removal

1. Remove heater (see 8.7.1.1).
2. Remove casing parts (see 9.2.1).
3. Remove control unit (see 9.2.3.1).
4. Remove overheating sensor (see 9.2.4.1).
5. Remove combustion and hot air fan (see 9.2.5.1).
6. Remove control unit (see 9.2.6.1).
7. Remove 2 screws (1, Fig. 904) and pull combustion chamber (4) out of heat exchanger (6).
8. Remove round sealing ring (5) from heat exchanger (6) and discard.
9. Complete work on stripped down components (see 9.1.1).

9.2.7.2 Installation

1. Insert new round sealing ring (5, Fig. 904) into heat exchanger (6).
2. Secure combustion chamber (4) with 2 screws on opposite sides (1).
3. Tighten screws (1) to 4 ± 0.4 Nm.
4. Install burner (see 9.2.6.2).
5. Mount combustion and hot air fan (see 9.2.5.2).
6. Install control unit (see 9.2.3.2).
7. Mount overheating sensor (see 9.2.4.2).
8. Mount casing parts (see 9.2.2).
9. Install heater (see 8.7.1.2)

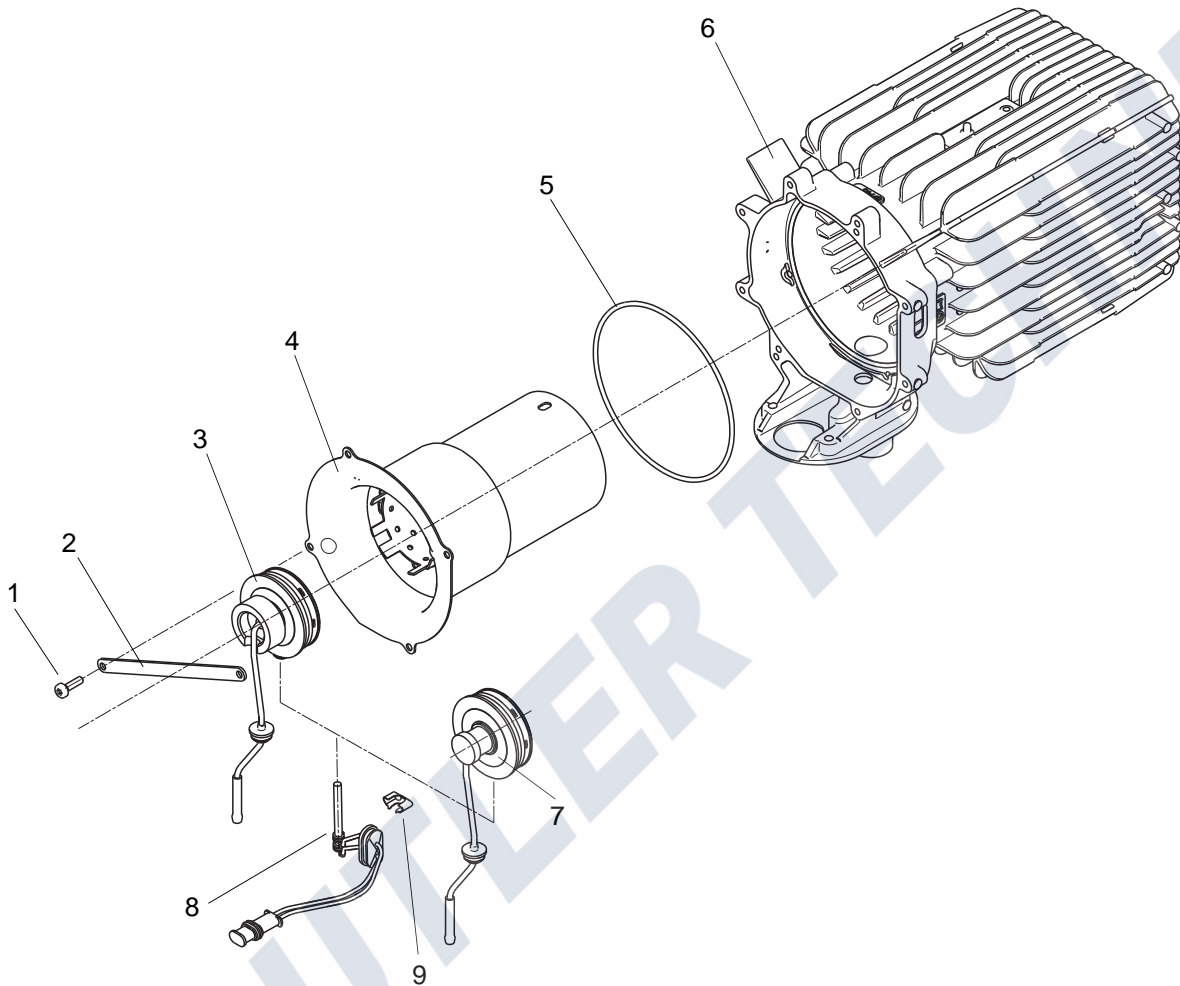

- 1 Torx screw (4)
- 2 Clamping bar
- 3 Diesel burner
- 4 Combustion chamber
- 5 Round sealing ring
- 6 Heat exchanger
- 7 Petrol burner
- 8 Glow plug/Flame monitor
- 9 Retaining clip

Fig. 904 Change burner, glow plug/flame sensor, combustion chamber and heat exchanger

10 Packaging, storage and shipping

10.1 General

If the heater or its components are sent to Webasto Thermo & Comfort SE for testing or repair, it must be cleaned and packed in such a way that it is protected against damage during handling, transport and storage.

An ambient temperature of +85 °C or –40 °C must not be exceeded for storage.

For details please contact your Webasto representative.

BUTLER TECHNIK

BUTLER TECHNIK

BUTLER TECHNİK

Webasto Thermo & Comfort SE
Postfach 1410
82199 Gilching
Germany

Visitors Address:
Friedrichschafener Str. 9
82205 Gilching
Germany

Internet: www.webasto.com

Technical Extranet: <http://dealers.webasto.com>

The telephone number of the respective country is shown on the Webasto service center leaflet of can be found on the website of your Webasto subsidiary.