

**Luftheizgeräte**  
**Air heaters**  
**Luchtverwarmingsapparaten**

**Einbauanweisung**  
**Installation Instructions**  
**Montagehandleiding**

**Air Top Evo 3900**

Handelsbezeichnungen / Trade names / Handelsnamen:

Air Top Evo 3900 B (Benzin) (petrol) (benzine)

Air Top Evo 3900 D (Diesel/PME) (diesel/PME)

Air Top Evo 5500 B (Benzin) (petrol) (benzine)

Air Top Evo 5500 D (Diesel/PME) (diesel/PME)

**BUTLER TECHNIK**



Das unsachgemäße Einbauen oder Reparieren von Webasto Heiz- und Kühlsystemen kann Feuer verursachen oder zum Austritt von tödlichem Kohlenmonoxid führen. Dadurch können schwere oder tödliche Verletzungen hervorgerufen werden.

Für den Einbau und die Reparatur von Webasto Heiz- und Kühlsystemen bedarf es eines Webastotrainings, technischer Dokumentation, Spezialwerkzeuge und einer Spezialausrüstung.

Es dürfen nur Originalteile von Webasto verwendet werden. Siehe dazu auch Zubehörkatalog Luft- und Wasserheizgeräte von Webasto.

Versuchen Sie NIEMALS, Webasto Heiz- oder Kühlsysteme einzubauen oder zu reparieren, wenn Sie das Webastotraining nicht erfolgreich abgeschlossen und dabei die notwendigen technischen Fähigkeiten erworben haben und die für einen sachgerechten Einbau und Reparatur nötigen technischen Dokumentationen, Werkzeuge und Ausrüstungen nicht zur Verfügung stehen.

Befolgen Sie IMMER alle Webasto Einbau- und Reparaturanleitungen, und beachten Sie alle Warnhinweise.

Webasto übernimmt keine Haftung für Mängel und Schäden, die auf einen Einbau durch ungeschultes Personal zurückzuführen sind.



Improper installation or repair of Webasto heating and cooling systems can cause fire or the leakage of deadly carbon monoxide leading to serious injury or death.

To install and repair Webasto heating and cooling systems you need to have completed a Webasto training course and have the appropriate technical documentation, special tools and special equipment.

Only genuine Webasto parts may be used. See also Webasto air and water heaters accessories catalogue.

NEVER try to install or repair Webasto heating or cooling systems if you have not completed a Webasto training course, you do not have the necessary technical skills and you do not have the technical documentation, tools and equipment available to ensure that you can complete the installation and repair work properly.

ALWAYS carefully follow Webasto installation and repair instructions and heed all WARNINGS.

Webasto rejects any liability for problems and damage caused by the system being installed by untrained personnel.



## Inhaltsverzeichnis

1	Gesetzliche Bestimmungen für den Einbau	1
2	Verwendung / Ausführung	5
3	Einbau	6
4	Typschild	9
5	Einbaubeispiel	10
6	Heizluftsystem	13
7	Brennstoffversorgung	15
8	Brennluftversorgung	20
9	Abgasleitung	21
10	Brennluftansaug- und Abgasleitungen	22
11	Elektrische Anschlüsse	24
12	Anschlussschema / Schaltplan	28
13	Legende für Schaltpläne	37
14	Erstinbetriebnahme	39
15	Störabschaltung	41
16	Technische Daten	43
17	Bohrschablonen	47

## Table of contents

1	Statutory regulations governing installation	51
2	Use / version	55
3	Installation	56
4	Type label	59
5	Installation example	60
6	Hot air system	63
7	Fuel supply	65
8	Combustion air supply	70
9	Exhaust pipe	71
10	Combustion air inlet and exhaust lines	72
11	Electrical connections	74
12	Connection diagram/Circuit diagram	78
13	Legend for circuit diagrams	87
14	Initial start-up	89
15	Fault lock-out	91
16	Technical data	93
17	Drilling templates	97

## 1 Statutory regulations governing installation

The Air Top Evo 3900 and Air Top Evo 5500 heaters have been type-tested and approved in accordance with Directives ECE R10 and EC 72/245/EEC (EMC) and ECE R122 and 2001/56/EC (heater) with the following EC permit numbers:

EMC: e1\*72/245\*2006/96\*5529\* \_\_ (Air Top Evo 3900 / 5500)  
E1 03 5529 (Air Top Evo 3900 / 5500)

Heater: e1\*2001/56\*2006/119\*0255\* \_\_ (Air Top Evo 3900)  
E1 00 0255 (Air Top Evo 3900)  
e1\*2001/56\*2006/119\*0256\* \_\_ (Air Top Evo 5500)  
E1 00 0256 (Air Top Evo 5500)

Primarily the regulations of Annex VII of the Directive 2001/56/EC and Part I and Annex 7 of the directive ECE R122 must be observed for the installation.

### NOTE:

**The specifications of this Directive are binding in the scope of the Basic Directive EEC/70/156 and/or EC/2007/46 (for new vehicle models from 29/04/2009) and should also be observed in countries in which no special regulations exist.**

**See chapter 1.2, "Extract from directives 2001/56/EC Annex VII and ECE R122 Part I and Annex 7" and chapter 1.3, "Extract from directives 2001/56/EC Annex IX and ECE R122 Annex 9".**

### IMPORTANT

Failure to follow the installation instructions and the notes contained therein will lead to all liability being refused by Webasto. The same applies if repairs are carried out incorrectly or with the use of parts other than genuine spare parts. This will result in the invalidation of the type approval for the heater and therefore of its *homologation / EC type licence*.

### NOTE:

For vehicles with an EU permit, no entry in accordance with § 19 Sub-Section 4 of Annex VIII b to the Road Traffic Act is required.

#### 1.1. Application of combustion heaters in vehicles for transporting dangerous goods

Vehicles for the purpose of transporting dangerous goods will be type tested in accordance with the standard ECE R105. The following measures are derived for our combustion heaters:

- The electrical cable/wiring harness must be sufficiently dimensioned to prevent overheating. The electrical cable/wiring harness must be sufficiently insulated. All power circuits must be protected with fuses or automatic circuit-breakers.
- The cables must be securely fastened and routed so that they are sufficiently protected against mechanical and thermal loading.
- The combustion heaters must be type-tested in accordance with the standard ECE R122 (equivalent to EC/2001/56 in the version EC/2006/119) and comply with the Appendix 9 – Additional regulations for vehicles for transporting dangerous goods.
- The combustion heaters and their exhaust gas routing shall be designed, located, protected or covered so as to prevent any unacceptable risk of heating or ignition of the load.
- In the event of any leakage of the fuel line, the fuel shall drain to the ground without coming into contact with hot parts of the vehicle or the load;
- The exhaust system as well as the exhaust pipes shall be so directed or protected to avoid any danger to the load through heating or ignition. Parts of the exhaust system situated directly below the fuel tank shall have a clearance of at least 100 mm or be protected by a thermal shield.

- The combustion heater may only be switched on manually. Programming devices shall be prohibited. The combustion heater may be switched on again manually after the vehicle engine has been switched off.

### Requirement for basic unit:

A maximum run-on period of 40 seconds is permitted when the combustion heater is switched off. Only combustion heaters with heat exchangers that are approved for this reduced run-on time of 40 seconds may be used.

### 1.2. Extract from directives 2001/56/EC Annex VII and ECE R122 Part I and Annex 7

Start of extract.

#### ANNEX VII

#### REQUIREMENTS FOR COMBUSTION HEATERS AND THEIR INSTALLATION

##### 1. GENERAL REQUIREMENTS

1.7.1. / 7.1. (Annex 7) A clearly visible tell-tale in the operator's field of view shall inform when the combustion heater is switched on or off.

##### 2. / 5.3. (Part I) VEHICLE INSTALLATION REQUIREMENTS

###### 2.1. / 5.3.1. (Part I) Scope

2.1.1. / 5.3.1.1. (Part I) Subject to paragraph 2.1.2. / 5.3.1.2. (Part I) combustion heaters shall be installed according to the requirements of this Annex.

2.1.2. / 5.3.1.2. (Part I) Vehicles of category O having liquid fuel heaters are deemed to comply with the requirements of this Annex.

###### 2.2. / 5.3.2. (Part I) Positioning of heater

2.2.1. / 5.3.2.1. (Part I) Body sections and any other components in the vicinity of the heater must be protected from excessive heat and the possibility of fuel or oil contamination.

2.2.2. / 5.3.2.2. (Part I) The combustion heater shall not constitute a risk of fire, even in the case of overheating. This requirement shall be deemed to be fulfilled if the installation ensures an adequate distance to all parts and suitable ventilation, by the use of fire resistant materials or by the use of heat shields.

2.2.3. / 5.3.2.3. (Part I) In the case of M2 and M3 vehicles, the heater must not be positioned in the passenger compartment. However, an installation in an effectively sealed envelope which also complies with the conditions in paragraph 2.2.2. / 5.3.2.2. (Part I) may be used.

2.2.4. / 5.3.2.4. (Part I) The label referred to in paragraph 1.4 / Annex 7 paragraph 1.4. or a duplicate, must be positioned so that it can be easily read when the heater is installed in the vehicle.

2.2.5. / 5.3.2.5. (Part I) Every reasonable precaution should be taken in positioning the heater to minimise the risk of injury and damage to personal property.

###### 2.3. / 5.3.3. (Part I) Fuel supply

2.3.1. / 5.3.3.1. (Part I) The fuel filler must not be situated in the passenger compartment and must be provided with an effective cap to prevent fuel spillage.

2.3.2. / 5.3.3.2. (Part I) In the case of liquid fuel heaters, where a supply separate to that of the vehicle is provided, the type of fuel and its filler point must be clearly labelled.

2.3.3. / 5.3.3.3. (Part I) A notice, indicating that the heater must be shut down before refuelling, must be affixed to the fuelling point. In addition a suitable instruction must be included in the manufacturer's operating manual.

**2.4. / 5.3.4. (Part I) Exhaust system**

2.4.1. / 5.3.4.1. (Part I) The exhaust outlet must be located so as to prevent emissions from entering the vehicle through ventilators, heated air inlets or opening windows.

**2.5. / 5.3.5. (Part I) Combustion air inlet**

2.5.1. / 5.3.5.1. (Part I) The air for the combustion chamber of the heater must not be drawn from the passenger compartment of the vehicle.

2.5.2. / 5.3.5.2. (Part I) The air inlet must be so positioned or guarded that blocking by rubbish or luggage is unlikely.

**2.6. / 5.3.6. (Part I) Heating air inlet**

2.6.1. / 5.3.6.1. (Part I) The heating air supply may be fresh or recirculated air and must be drawn from a clean area not likely to be contaminated by exhaust fumes emitted either by the propulsion engine, the combustion heater or any other vehicle source.

2.6.2. / 5.3.6.2. (Part I) The inlet duct must be protected by mesh or other suitable means.

**2.7. / 5.3.7. (Part I) Heating air outlet**

2.7.1. / 5.3.7.1. (Part I) Any ducting used to route the hot air through the vehicle must be so positioned or protected that no injury or damage could be caused if it were to be touched.

2.7.2. / 5.3.7.2. (Part I) The air outlet must be so positioned or guarded that blocking by rubbish or luggage is unlikely.

**2.8. / 5.3.8. (Part I) Automatic control of the heating system**

2.8. / 5.3.8.1. (Part I) The heating system must be switched off automatically and the supply of fuel must be stopped within five seconds when the vehicle's engine stops running. If a manual device is already activated, the heating system can stay in operation.

End of extract.

**1.3. Extract from directives 2001/56/EC Annex IX and ECE R122 Annex 9**

Start of extract.

**ANNEX IX / 9**

**3. Technical specifications for heater units for installation in dangerous goods transporters (Annex 9)**

**3.1. General (EX/II, EX/III, AT, FL and OX vehicles)**

3.1.1. The combustion heaters and their exhaust gas routing shall be designed, located, protected or covered so as to prevent any unacceptable risk of heating or ignition of the load. This requirement shall be considered as fulfilled if the fuel tank and the exhaust system of the appliance conform to the provisions set out in the points 3.1.1.1 and 3.1.1.2. Compliance with those provisions shall be verified on the completed vehicle.

3.1.1.1. Any fuel tanks for supplying the appliance shall meet the following requirements:

- a) in the event of any leakage, the fuel shall drain to the ground without coming into contact with hot parts of the vehicle or the load;
- b) fuel tanks containing petrol shall be equipped with an effective flame trap at the filler opening or with a closure enabling the opening to be kept hermetically sealed.

3.1.1.2. The exhaust system as well as the exhaust pipes shall be so directed or protected to avoid any danger to the load through heating or ignition. Parts of the exhaust system situated directly below the fuel tank (diesel) shall have a clearance of at least 100 mm or be protected by a thermal shield.

3.1.2. The combustion heater shall be switched on manually. Programming devices shall be prohibited.

**3.2. EX/II and EX/III vehicles**

Combustion heaters using gaseous fuels are not permitted.

**3.3. FL vehicles**

3.3.1. The combustion heaters shall be put out of operation by at least the following methods:

- a) intentional manual switching off from the driver's cab;
- b) stopping of the vehicle engine; in this case the heating device may be restarted manually by the driver;
- c) start-up of a feed pump on the motor vehicle for the dangerous goods carried.

End of extract.



## **2 Use / version**

### **2.1. Use of the air heaters**

The Webasto Air Top Evo 3900 and Air Top Evo 5500 air heaters are designed

- to heat cabins, boats, trucks, minibuses, vans, ambulances and motorhomes
- to defrost vehicle windows
- to heat cargo

The heaters operate independently of the engine and are connected directly to the fuel tank and the electrical system of the vehicle.

They may be used for vehicles with either water or air-cooled engines.

They are not approved for heating the space in which dangerous goods are transported.

### **2.2. Version**

**Air Top Evo 3900 B (petrol)**

**Air Top Evo 5500 B (petrol)**

Air Heater for "Petrol" Fuel (12 V)

**Air Top Evo 3900 D (diesel)**

**Air Top Evo 5500 D (diesel)**

Air Heater for "Diesel" Fuel (12 or 24 V)

## Installation

### 3 Installation

#### IMPORTANT

The statutory regulations governing installation (see chapter 1, "Statutory regulations governing installation") must be adhered to. The requirements of the latest version of the ADR must also be observed for the installing the heater into vehicles used to transport hazardous substances.

The heater must not be operated without the control unit cover (this will cause the heater to overheat).

#### 3.1. Air Top Evo 3900 / Air Top Evo 5500 installation situation

##### NOTE:

Check the installation situation of the relevant vehicle type.

#### 3.2. Installation location

The heater may be fitted both in the interior or on the exterior of the vehicle.

**When using the vehicle in normal road traffic, the heater may only be installed with contact protection if it is located within reach of the driver.**

If it is installed on the exterior ensure that the heater is fitted in a position where it is protected from splashing water and spray. The heater must be installed in such a way that no water can ingress into it if the vehicle travels through a water hazard for which that vehicle is licensed.

The openings for the combustion air inlet port, the exhaust outlet port and the fuel pipe must be sealed if the heater is installed in the interior. The seal designed and supplied for this purpose must be used (see Figure 3).

#### 3.3. To install the heater

The M6 nuts must be tightened with a torque of 6 Nm (-0 Nm,+1 Nm) for installing the Air Top Evo 3900 or Air Top Evo 5500 heater.

The installation dimensions and space requirement for service access are shown in the installation drawing (Figure 1). The specified horizontal and axial angles must not be exceeded (Figure 2).

A seal (Figure 3) must be fitted between the heater and the vehicle body. **This seal must be replaced each time the heater is installed.** The support area for the heater foot **must be flat**. A special tools can be purchased from Webasto to drill the holes and, if necessary, smooth the support area. The seal can compensate for unevenness of max. 1 mm.

##### IMPORTANT

After installation, check that the casing is not in contact with any parts of the vehicle body. A failure to do this may result in the hot air fan blocking.

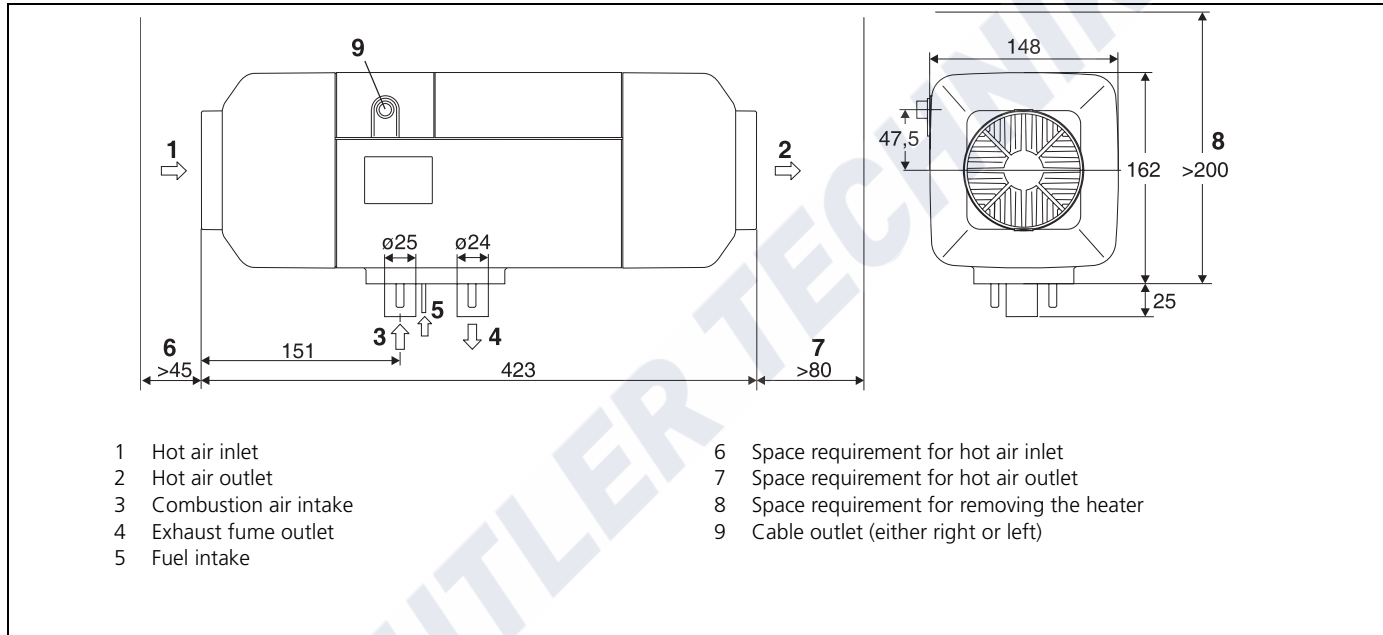

**Fig. 1** Dimensions of the heater

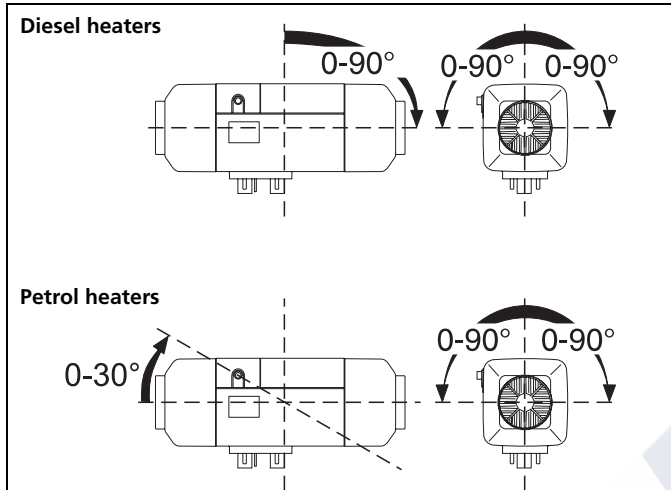

Fig. 2 Approved installation position

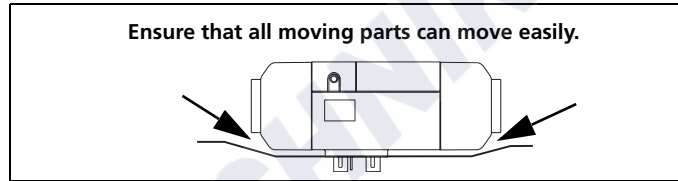

Fig. 4 Installation

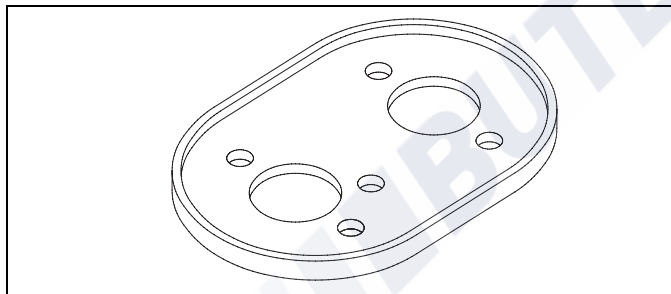

Fig. 3 Seal

#### **4 Type label**

The model plate must be positioned so that it cannot be damaged and must be clearly legible when the heater is installed (otherwise a duplicate model plate must be used).

Inapplicable years must be erased from the model plate.



5 Installation example

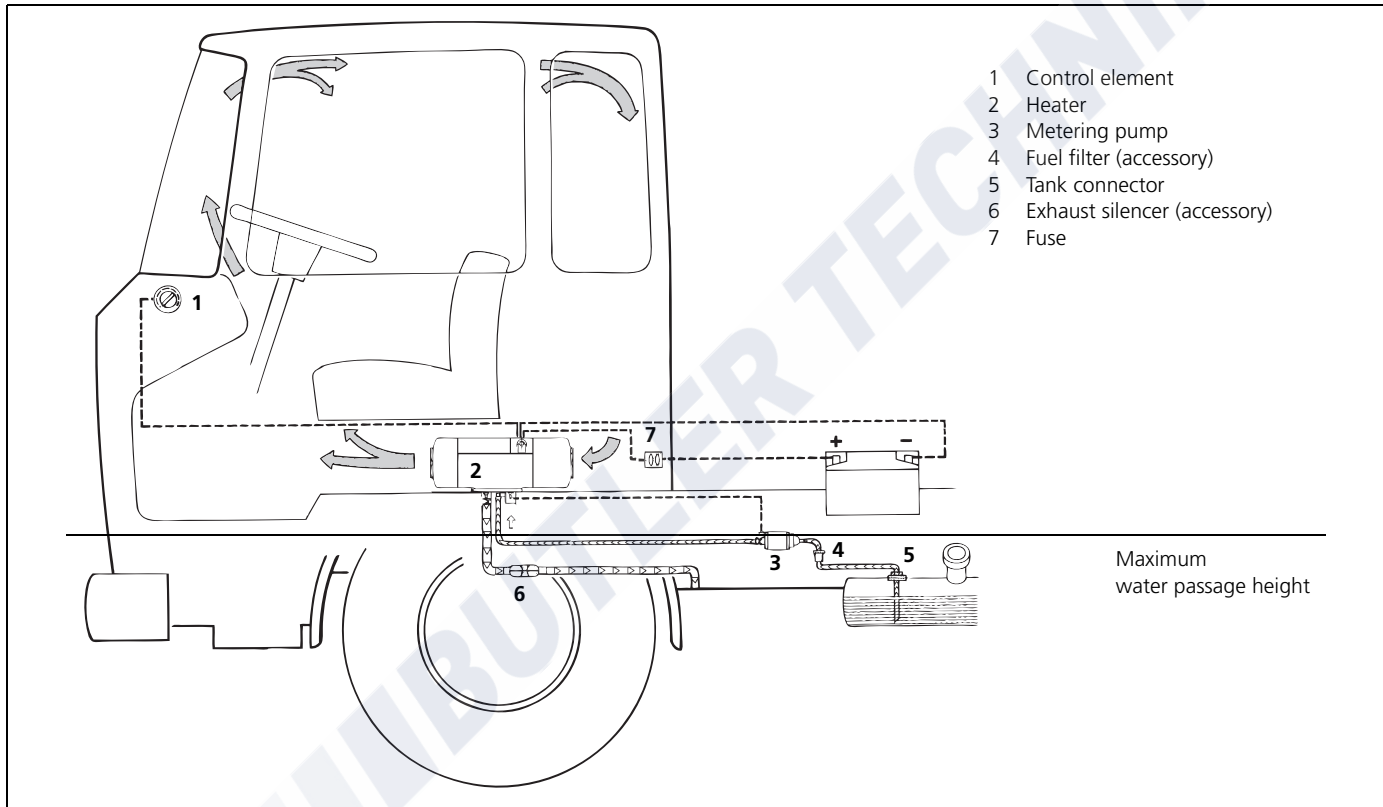

Fig. 5 Installation example for air heater in recirculation mode

**5.1. Design as system**

The variants Air Top Evo 3900 AM and Air Top Evo 5500 AM enable up to 4 heaters to be operated in one system. Here Unit 1 is defined as the master heater and others as slave heaters. The heater control and an external temperature sensor (T) are connected to the master heater (see wiring diagram in Figure 34, 36 and 38). The slave heater is connected in accordance with the wiring diagram (see Figure 39). The units communicate with each other via a serial bus system. This system can therefore be individually adapted to the applications by combining several heaters.

**IMPORTANT**

The use of an Air Top Evo 3900 AM or Air Top Evo 5500 AM system is not approved for dangerous goods transports (ADR)!

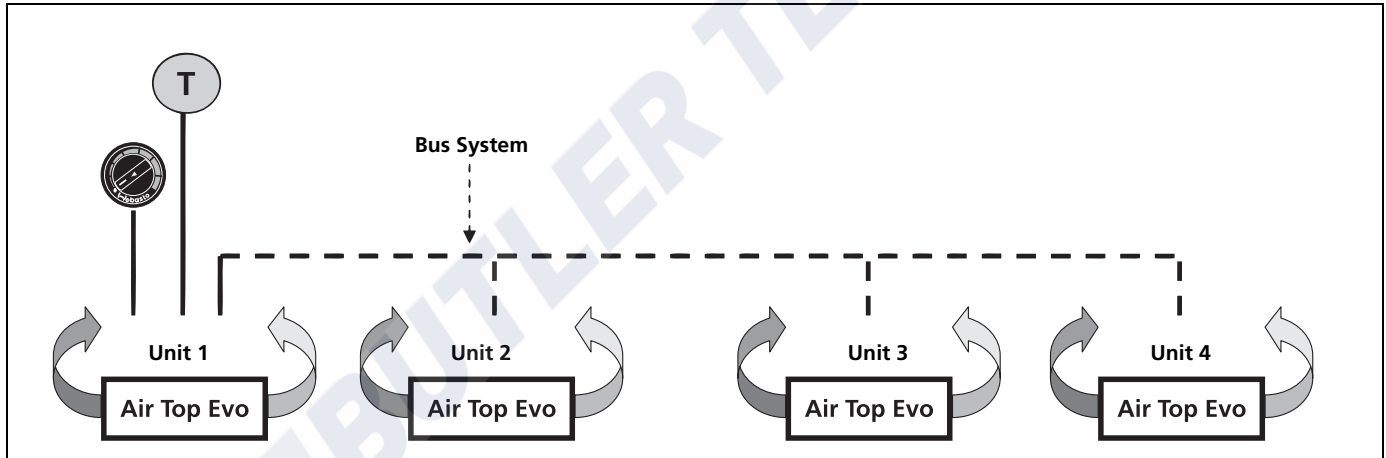

**Fig. 6 System design**

**5.2. Heating Capacity of Entire System**

Heating Capacity Range	Heater	Number of Units
1.5 - 3.9 kW	Air Top Evo 3900	1
1.5 - 5.5 kW	Air Top Evo 5500	1
1.5 - 7.8 kW	Air Top Evo 3900	2
1.5 - 11.0 kW	Air Top Evo 5500	2
1.5 - 16.5 kW	Air Top Evo 5500	3
1.5 - 22.0 kW	Air Top Evo 5500	4

**NOTE:**

It is only permitted to install heating systems with Air Top Evo heaters of the same output type.



## 6 Hot air system

### NOTE:

The heater must not be integrated into the vehicle's air system.

Inside the control unit there is a temperature sensor, which operates the heater in the appropriate heat output range in conjunction with the control element depending on the intake temperatures and the position of the set-point generator. The heat output is controlled such that after the selected interior temperature has been reached quickly, it is then kept at this selected value.

Both recirculation and fresh air modes are possible.

For fresh air mode it must be ensured that the hot air is taken from an area protected from splashing water and spray and in such a way that no water can ingress into the heater if the vehicle travels through a water hazard for which that vehicle is licensed.

### NOTE:

For fresh air mode an external temperature sensor must be fitted in the appropriate zone.

Recommended internal diameter of the main section of the **hot air line**:  
90 mm for the Air Top Evo 5500 80 mm for the Air Top Evo 3900

### NOTE:

Only materials that can permanently withstand temperatures of at least 130 °C may be used for the hot air line. The hot air opening is to be positioned in such a way that the air is not blown on to any parts that cannot withstand the heat.

### IMPORTANT

In vehicles used to transport people, the air outlet opening is to be directed in such a way that it is at least 20 cm away from all body parts.

Maximum pressure drop between the inlet and outlet side of the hot air line:

Air Top Evo 3900 2.0 hPa

Air Top Evo 5500 3.0 hPa

1 hPa corresponds to 1 mbar corresponds to 10 mm water column.

The heaters check the internal temperature rise automatically each time they are switched on. If this is above the specified limits, the start is cancelled and error messages F10 is displayed. To ensure that the heater functions stably, the flow resistance of the connected hot air system must be reduced.

The points table for air guide parts in the Webasto catalogue may be used to design the hot air system.

The hot air hose must be secured at its connection points.

If the heater is used in recirculation mode without a hot air guide, do not short circuit the hot air flow.

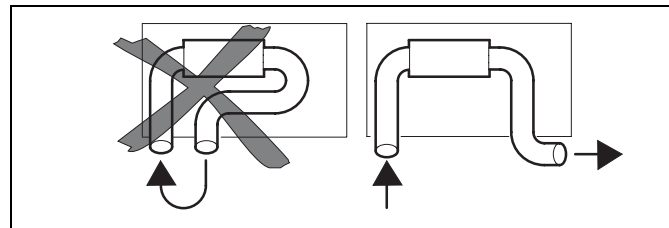

**Fig. 7 Hot air inlet and hot air outlet**

### IMPORTANT

If you use the heater without a hot air inlet hose, the inlet grille supplied with the heater must be used at all times.

### NOTE:

The installation must be checked for:

- Air short circuit between the vehicle's heating system and the heater air inlet
- Air short circuit between the heater's air inlet and the heater's air outlet (Figure 7)

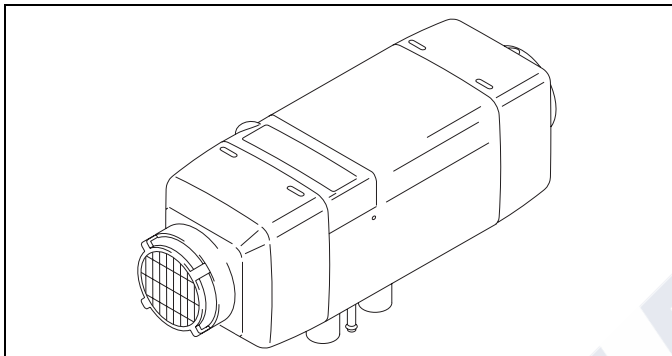

**Fig. 8 Hot air inlet with inlet grille**

If you use an installation box the air vent must be sealed in such a way that no hot air can get into the installation box.

### 6.1. External temperature sensor

For fresh air mode an external temperature sensor must be fitted in the appropriate zone.

#### 6.1.1. To install the external temperature sensor

The external temperature sensor must be installed at medium height in the passenger cabin on vertical surfaces if possible in the area that requires heating.

The temperature sensor must **not**

- be in the direct current of hot air (from the vehicle's own heating system or the hot air heater).
- be close to heat sources (for example the vehicle's own heating system).
- be placed in direct sunlight (for example on the dashboard).
- be installed behind curtains or the like.

## 7 Fuel supply

The fuel is taken from the vehicle fuel tank or from a separate fuel tank. The values for the maximum pressure at the fuel extraction point are shown in Figure 9.

Permissible fuel inflow height H (m)	At max. perm. pressure (bar) in fuel line
0,00	0,2
1,00	0,11
2,00	0,03
Maximum fuel intake height S (m)	At max. perm. negative pressure (bar) in the fuel tank
0,00	-0,10
0,50	-0,06
1,00	-0,02

Only for ADR: The statutory regulation of ADR (Accord européen relatif au transport international des marchandises dangereuses par route) governing fuel tanks, part 9 para. 9.2.4.7, must be adhered to.

A sign must be affixed to the fuel filler neck warning that the heater must be switched off before refuelling.

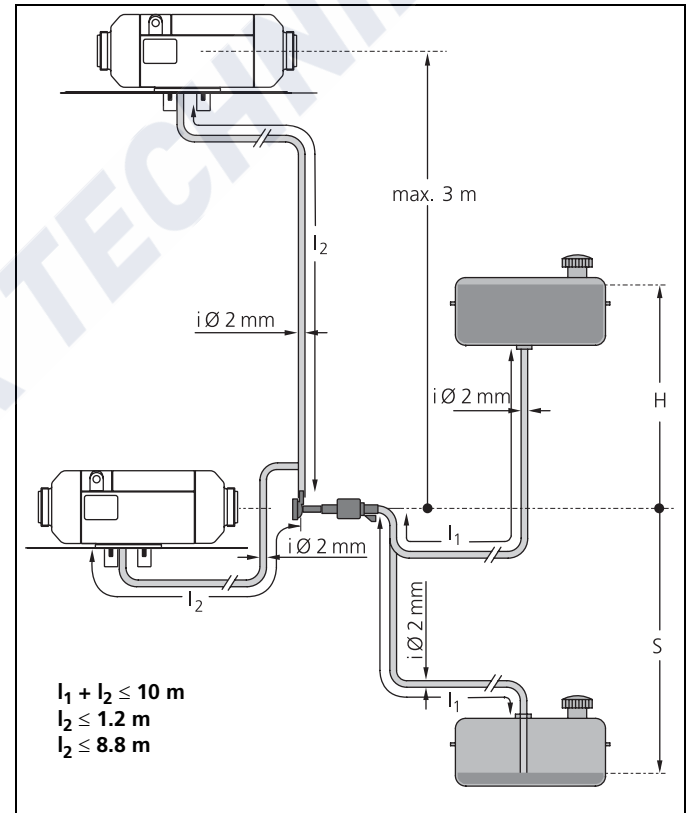

Fig. 9 Fuel supply

## Fuel supply

### 7.1. Vehicles with carburettor engines

The fuel may only be extracted using the special Webasto fuel extractor (see Figure 10) as close to the tank as possible. The connect may be made in either the supply or return line, in which case the return line must lead almost to the base of the tank (see Figure 11).

The fuel extractor must be fitted in such a way that any air or gas bubbles are automatically discharged towards the tank (see Figure 10).

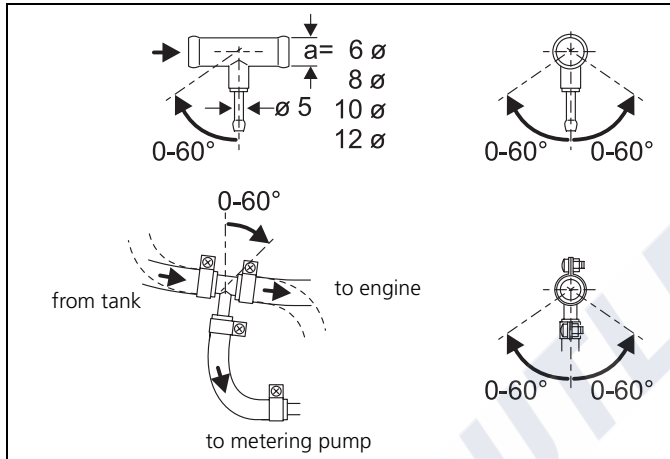

**Fig. 10 Webasto fuel extractor**

The fuel extractor should not be located near the engine, as gas bubbles may form in the lines on account of heat radiated from the engine. This may cause problems during combustion.

### 7.2. Vehicles with injection engines

When installing the heater in a vehicle with fuel injection system, it is important to establish whether the vehicles fuel pump is located inside or outside the tank.

If the fuel pump is located inside the tank, fuel can only be extracted from the return line using the Webasto fuel extractor (see Figure 10), in which case it must be checked to ensure that the fuel return pipe in the tank terminates near the bottom of the fuel tank (see Figure 11 for details of the minimum distance from the bottom of the tank). If this is not the case Webasto fuel extractor (see Figure 11, 12 and 13) may be used.

If the fuel pump is installed outside the tank, the fuel connection may also be made between the tank and the fuel pump, again using only the Webasto fuel extractor (see Figure 10).

### 7.3. Vehicles with diesel engines

The fuel must be taken from the vehicle fuel tank or from a separate tank (see Figs. 11, 12 and 13). This separate fuel pick-up precludes any effect of pressure.

**NOTE:**

The tank fitting must be made from metal!

### 7.4. Fuel lines

Only steel, copper and plastic lines of plasticised, light and temperature-stabilised PA 11 or PA 12 (e.g. Mecanyl RWTL) pursuant to DIN 73378 may be used for the fuel lines.

Since the lines normally cannot be routed with a constant rising gradient, the internal diameter must not be allowed to exceed a certain size. Air or gas bubbles will accumulate in lines with an internal diameter of more than 4 mm and these will cause malfunctions whilst the heater is operating if

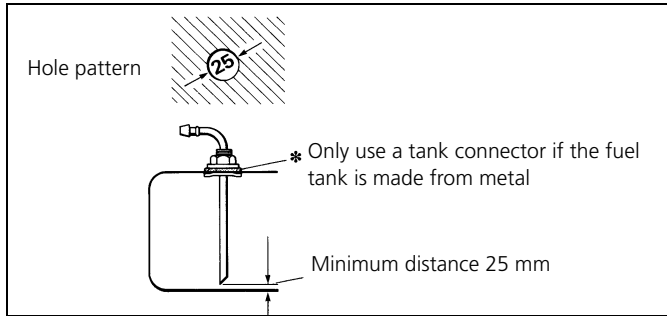

**Fig. 11 Webasto tank connector**

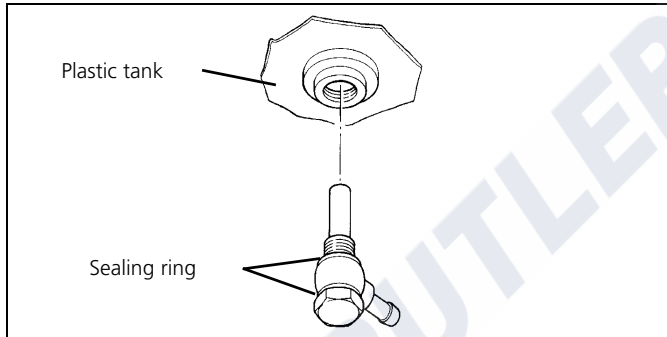

**Fig. 12 Fuel pick-up from the plastic tank**  
(Pick-up via tank drain screw)

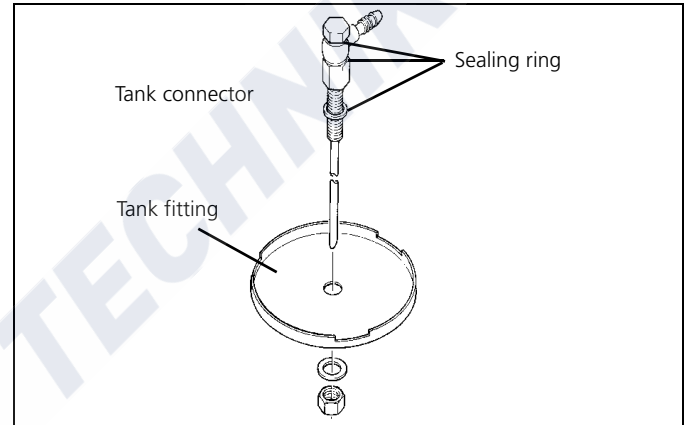

**Fig. 13 Fuel pick-up from the plastic tank**  
(Pick-up via tank fitting)

Unsupported fuel lines must be secured to prevent them sagging. They must be installed in such a way that they cannot be damaged by flying road chippings and high temperatures (exhaust line). The fuel lines must be secure at the connections using hose clips to prevent their slipping.

the lines sag or are routed downwards. The diameters specified in Figure 9 will ensure that bubbles do not form.

The lines should not be routed downwards from the metering pump to the heater.

## Fuel supply

### 7.4.1. Connecting two pipes with a hose

The correct procedure for connecting fuel lines with hosing is shown in Figure 14.

Ensure that there are no leaks.

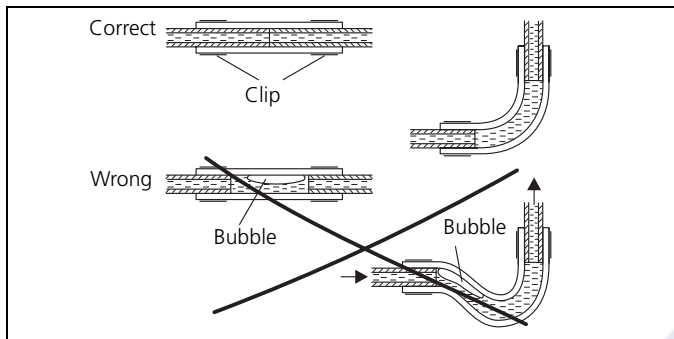

**Fig. 14 Pipe / hose connection**

### 7.5. Metering pump

The metering pump is a combined delivery, metering and shut-off system and is subject to certain installation criteria (see Figures 9, 15 and 16).

#### 7.5.1. Installation location

The metering pump must be installed in a cool place as close as possible to the tank (see Figure 9). The maximum ambient temperature must not exceed +20 °C for petrol heaters at any time during operation.

The metering pump and fuel lines must not be installed within range of the radiated heat from hot vehicle parts. A heat shield must be used if necessary.

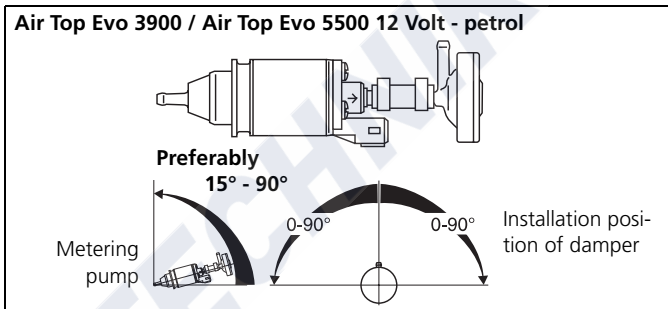

**Fig. 15 Metering pump DP 2 with damper**  
Installation position

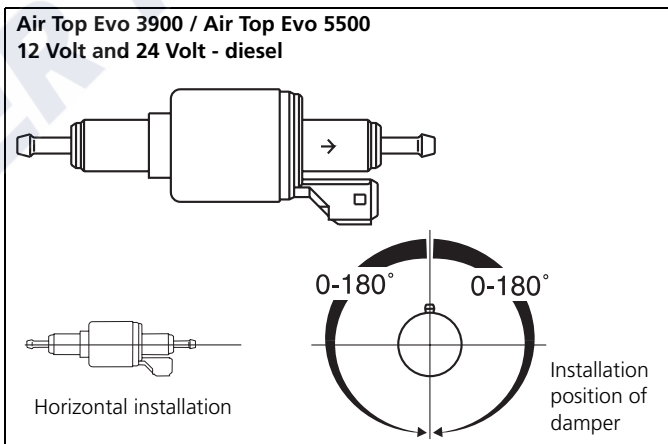

**Fig. 16 Metering pump DP 30.2**  
Installation position

**7.5.2. Installation and attachment**

The metering pump must be secured with a vibration-damping mounting (for example a rubberised clip). Its installation position is limited as shown in Figures 15 and 16 in order to ensure effective automatic bleeding.  
As a result of the risk of corrosion, only genuine Webasto parts may be used for the plug connections between the metering pump and the metering pump wiring harness.

**7.6. Fuel filter**

Only a Webasto filter, order no. 487 171, is allowed to be used if the fuel is expected to be contaminated. Install vertically if possible, however at least horizontally (check flow direction).

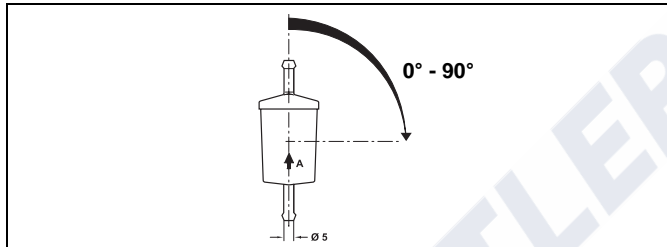

**Fig. 17 Air Top Evo 3900 and Air Top Evo 5500 fuel filter**

## 8 Combustion air supply

Under no circumstances may the combustion air be taken from areas occupied by people. The combustion air intake opening must not point in the direction of travel. It must be located so that it cannot become clogged with dirt.

**NOTE:**

An intake silencer must be fitted if the intake hose length is shorter than 0.6 m.

**NOTE:**

The combustion air must be extracted using a combustion air line from a position that is as cool as possible and protected from splashing water. Do not use an exhaust line as the combustion air line since otherwise the metering pump cable from the combustion air inlet port may be damaged. The combustion air opening must not be under the minimum water drive-through level permitted for the vehicle.

See the statutory regulations for the installation for further regulations.



## 9 Exhaust pipe

Rigid pipes of unalloyed or alloyed steel with a minimum wall thickness of 1.0 mm or flexible piping of alloyed steel only must be used as exhaust line. The exhaust pipe is secured to the heater using a clamping collar, for example. See the statutory regulations for other requirements.

The exhaust silencer should ideally be installed near the heater. The heater may also be operated without a silencer.

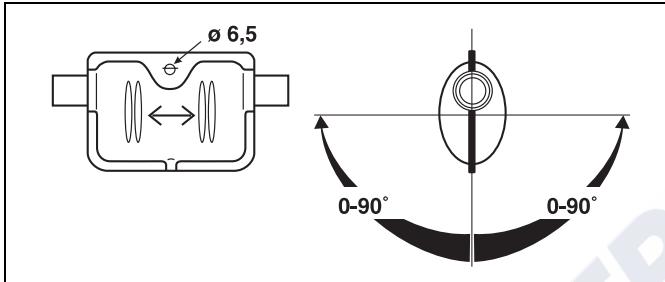

**Fig. 18 Exhaust silencer**  
Arbitrary flow direction

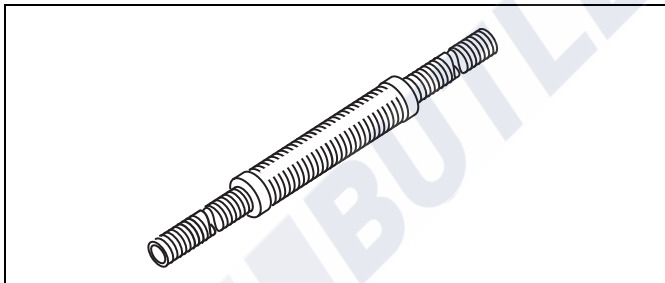

**Fig. 19 Exhaust silencer for boat applications**  
Flow direction and installation position arbitrary

## 10 Combustion air inlet and exhaust lines

Both lines are to be installed falling away from the heater. If this is not possible, a condensate drain hole with a diameter of 4 mm must be made at its lowest point.

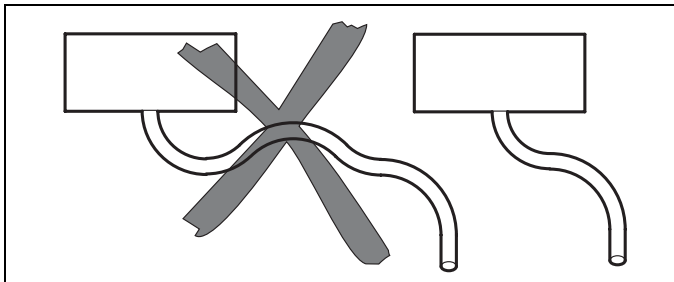

**Fig. 20 Prevent the formation of condensate**

The lines must not point to the front of the vehicle.

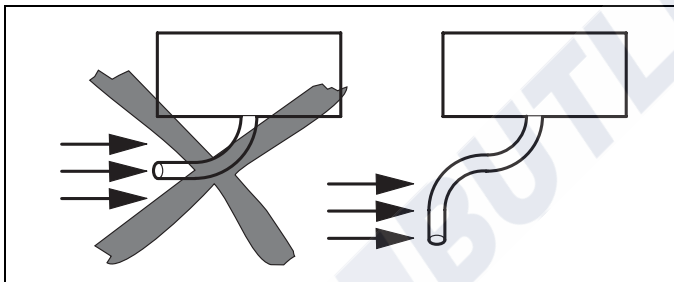

**Fig. 21 The lines must not end pointing towards the front of the vehicle**

The lines must be located so that they cannot become clogged with dirt.

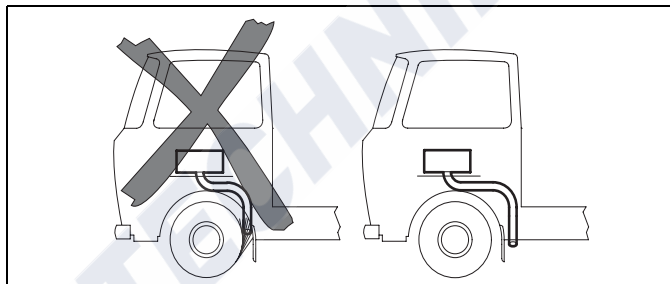

**Fig. 22 Avoid the lines becoming clogged with dirt**

### IMPORTANT

If the exhaust pipe ends is other than as shown in the Figure 23 it will pose a fire risk.

Length of the combustion air inlet and exhaust lines in total:

With exhaust silencer: max. 2.0 m

Without exhaust silencer: max. 5.0 m

### NOTE:

If the exhaust line is over 2 m in length the lines must be insulated (to prevent falling below the dew point)

Internal diameter of the lines:

Combustion air line: 25 mm

Exhaust line (metal): 24 mm

Minimum bending radius: 50 mm

Total bends:

Combustion air line: max. 270°

Exhaust line: max. 270°

An attachment is required no further than 150 mm from the end of the exhaust pipe to ensure that the angle of  $90^\circ \pm 10^\circ$  is achieved

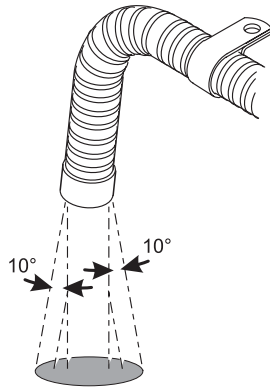

Discharge direction almost vertical  $90^\circ \pm 10^\circ$

**Fig. 23 Exhaust pipe opening**

Installation position

Only for ADR: The statutory regulation of ADR (Accord européen relatif au transport international des marchandises dangereuses par route) governing the routing of the exhaust line, part 9 para. 9.2.4.7, must be adhered to.

## 11 Electrical connections

All lines that are not required must be insulated at their free end.

### NOTE:

If the combination or standard timer is used, a touch-sensitive switch may be installed in the sleeping section to act as a remote control and improved convenience. The connections must be made as shown in the circuit diagrams in Figures 36 and 37.

The electrical connection is made as shown in the system circuit diagram (Figures 34 to 39).

### 11.1. Connection for installing the heater in a hazchem vehicle (ADR)

To install the Air Top Evo 3900 D and Air Top Evo 5500 D heaters in hazchem vehicles, the requirements of ADR/RID part 9 para. 9.2.4.7 – Combustion heating systems, must also be satisfied. The electrical connection is made as shown in the circuit diagram in Figure 35 and 39.

### NOTE:

The switch S3 must be installed in such a way that a positive potential is connected to appropriate input of the control module when a pumping device is switched on.

### IMPORTANT

All ADR functions are ineffective if there is no earth at control unit input X6/1 when the system is switched on. The control unit continues to run briefly for a maximum of 40 seconds and then switches to the "ADR lock-out" operating mode when a positive voltage is connected to control unit input X6/1 (auxiliary power take-off on) or the engine is switched off.

### IMPORTANT

In accordance with the regulations of the act governing the road/rail haulage of hazardous materials, heaters are only allowed to be taken into service with a special manually operated switch fitted in the cab.

If the system is equipped with a combination timer, ensure that contact 4 on the combination timer remains free. The heater can then only be taken into service using the immediate heat button.

The use of other timers in ADR vehicles is not permitted.

### 11.2. Heater connection

To connect the wiring harness, remove the control unit cover on the heater and connected the wiring harness plug to the control unit.

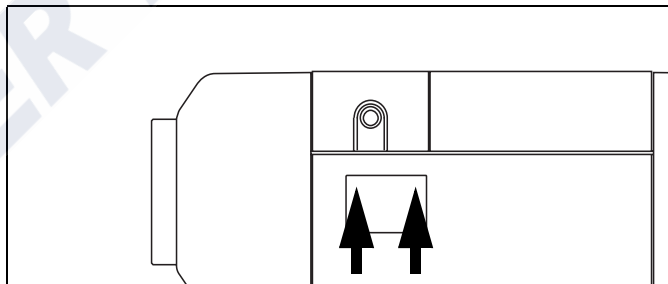

Fig. 24 Removing control unit cover

### NOTE:

Raise the control unit cover on both sides using a blunt blade (Figure 24 arrows).

Before using the heater for the first time fit the control unit cover to prevent the illegal escape of hot air (heater overheating).

The cable passage can be placed at either the left or right side. To ensure that the cable passage in the control unit cover seals correctly, the cable grommet is to be adjusted appropriately on the wiring harness.

### 11.3. Supply voltage connection

Ideally from the vehicle's central electrical system.

**An additional blade terminal fuse holder is to be fitted to protect the heater (supplied with the heater). The fuse holder may only be installed in the interior of the vehicle.**

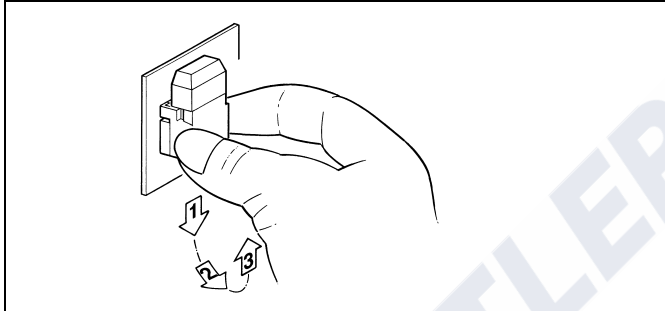

Fig. 25 Remove the fastening plate on the fuse holder

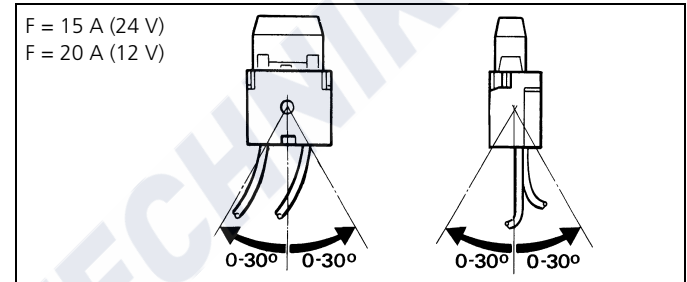

Fig. 26 Fuse holder, installation position

## Electrical connections

### 11.4. Control element connection

The wiring harness is prepared for connection to the control element. Simply pull on connector housing to unplug the connector. The connector housing can be locked (self-locking action) by simply pulling on the wiring harness.

**NOTE:**

The fibre optic cable must be in contact with the rotary knob

**NOTE:**

As an option an external temperature sensor may be installed in the passenger cabin (see page 64).

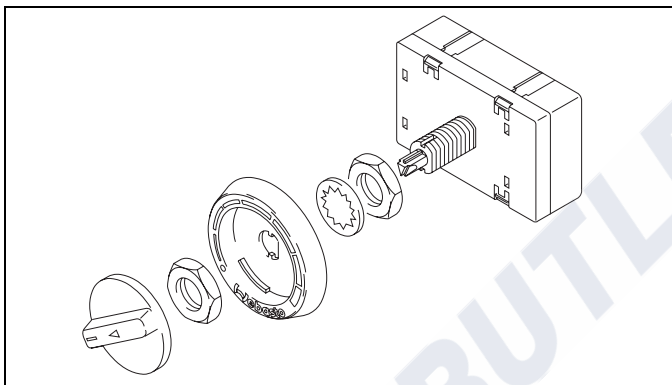

Fig. 27 Control element

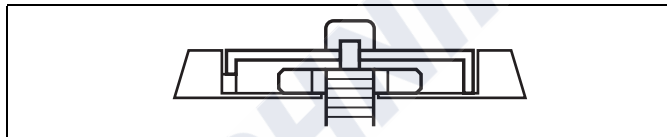

Fig. 28 Installation of the control element

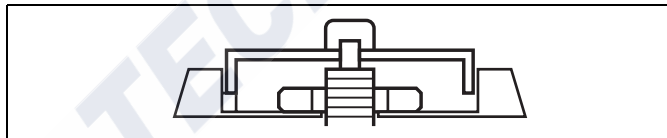

Fig. 29 Installation of the control element (incorrect)

**11.5. Installation Instructions for Control Panel MC04/05**

Install control panel:

The control panel should be installed in a suitable location (on a flat surface if possible) in the area visible to the driver.

- Use Drilling Template for control panel MC04/05 for cut-out and holes (see chapter 17, "Drilling templates");
- Connect control panel to existing connectors on heater-unit wiring harness (see chapter 12, "Connection diagram/Circuit diagram");
- Premount control unit in cut-out;
- Lightly press fastening screws into holes and screw in;
- Carefully clip on trim frame.

**NOTES:**

- control panel is only intended for installation in passenger compartment;
- Ensure good readability when selecting installation location;
- Observe information on adhesive labels and coloured markings when connecting control panel to vehicle wiring harness.

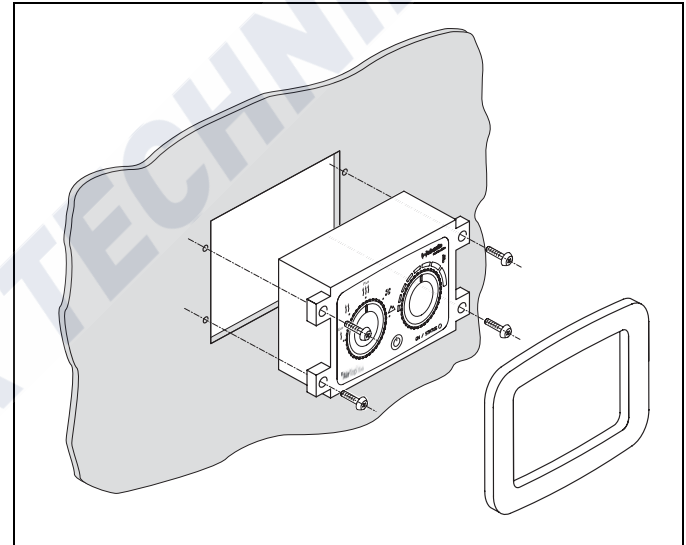

**Fig. 30** Installing Control Panel MC04/05

12 Connection diagram/Circuit diagram

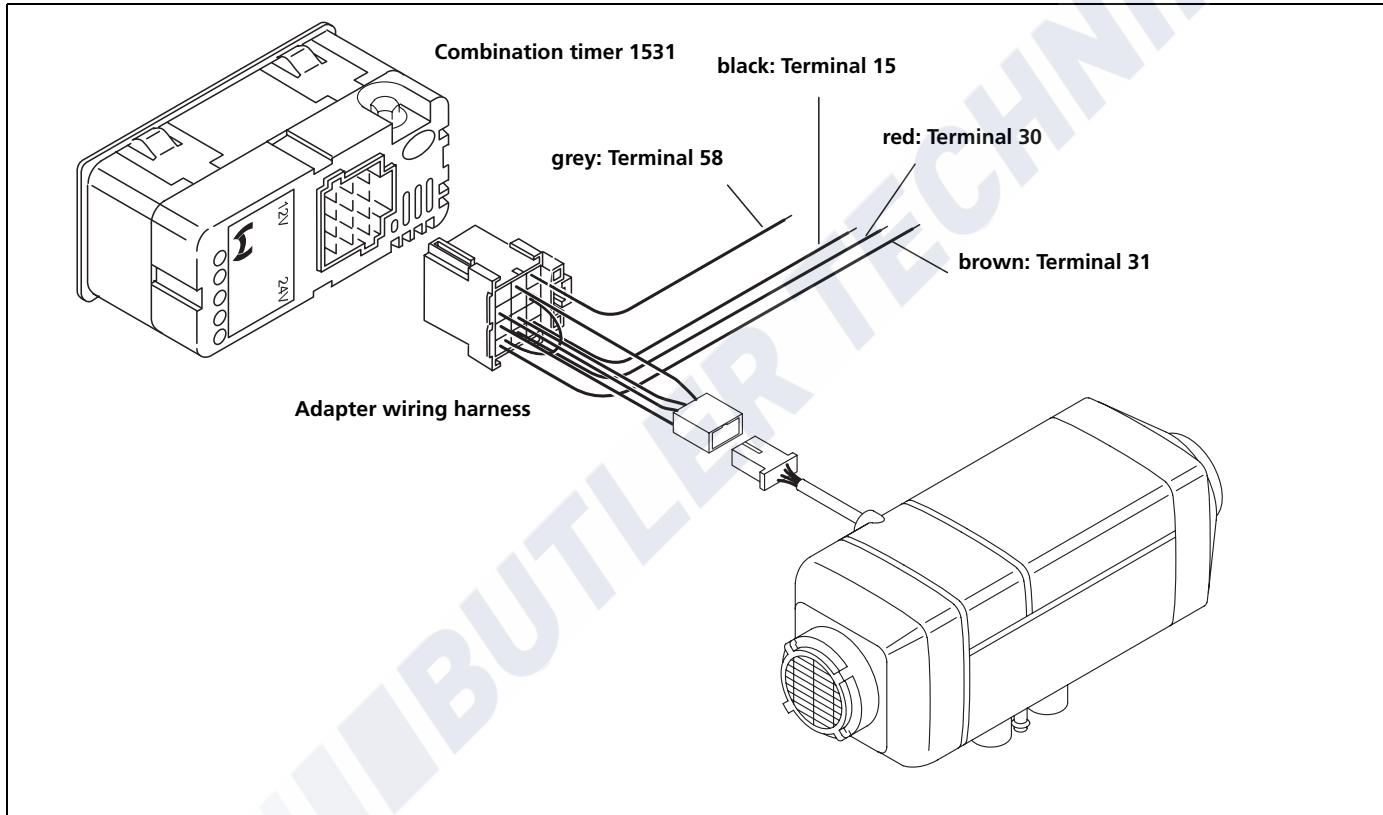

Fig. 31 Air Top Evo 3900 and Air Top Evo 5500 with combination timer connection diagram



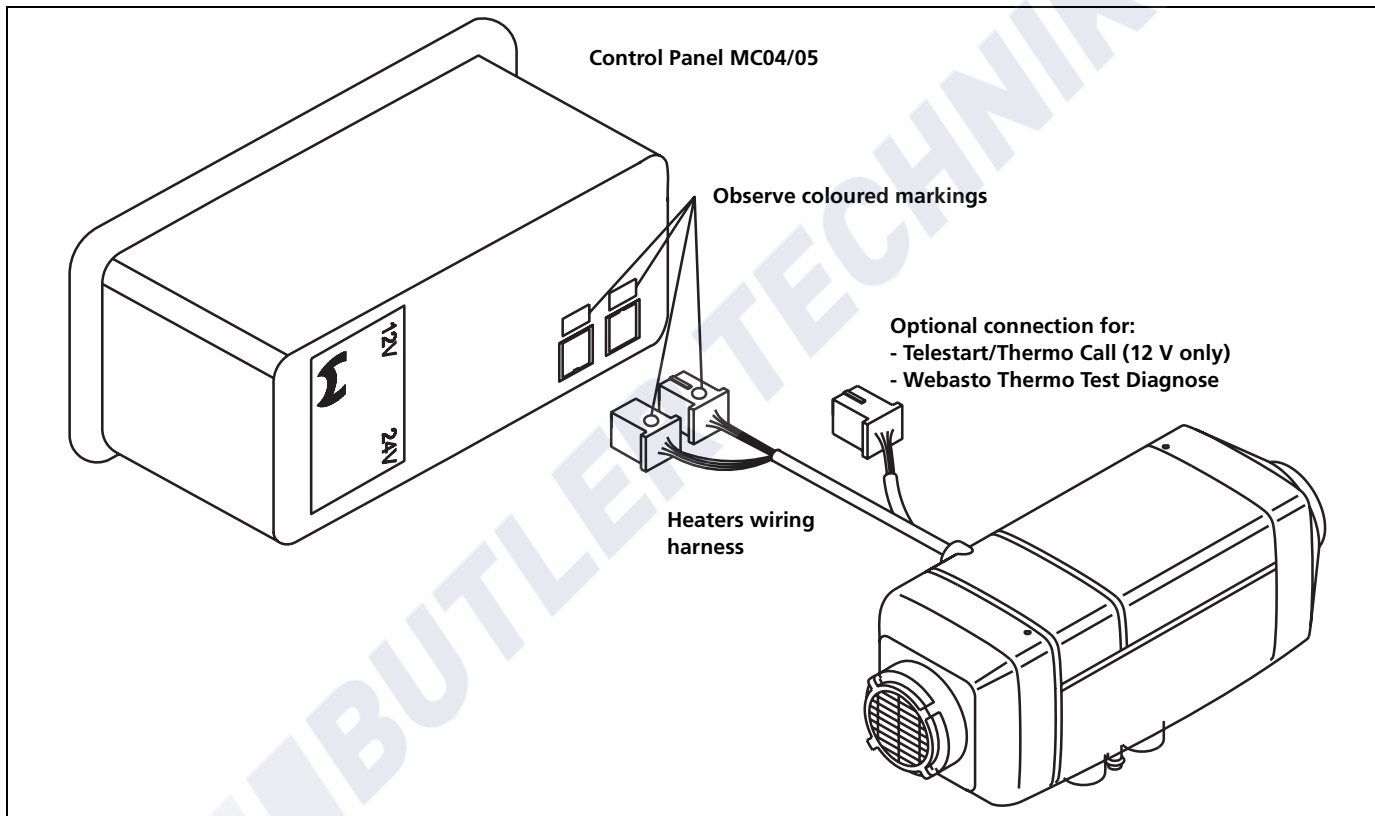

Fig. 32 Connection Diagram for Air Top Evo 3900 and Air Top Evo 5500 with Control Panel MC04/05

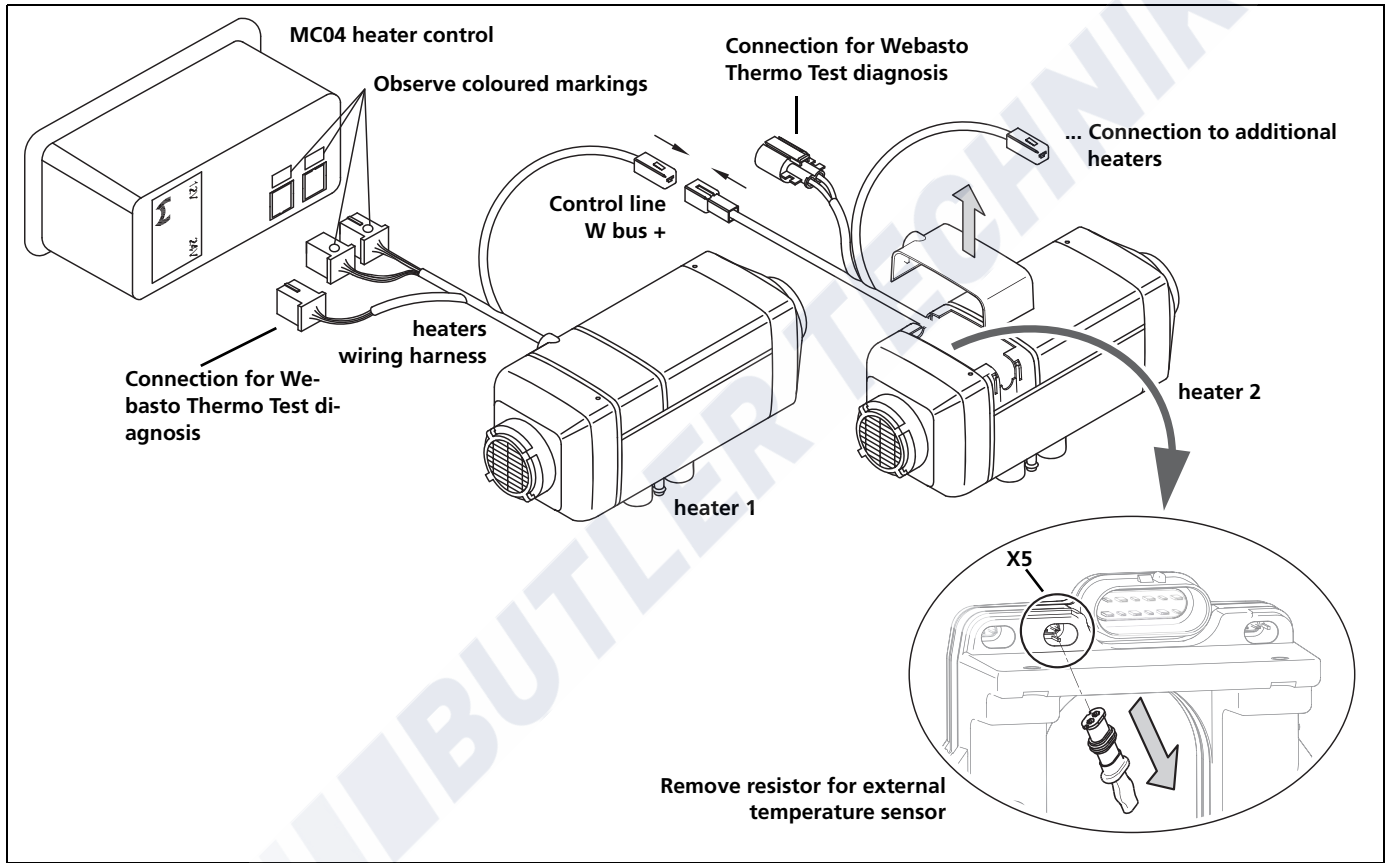
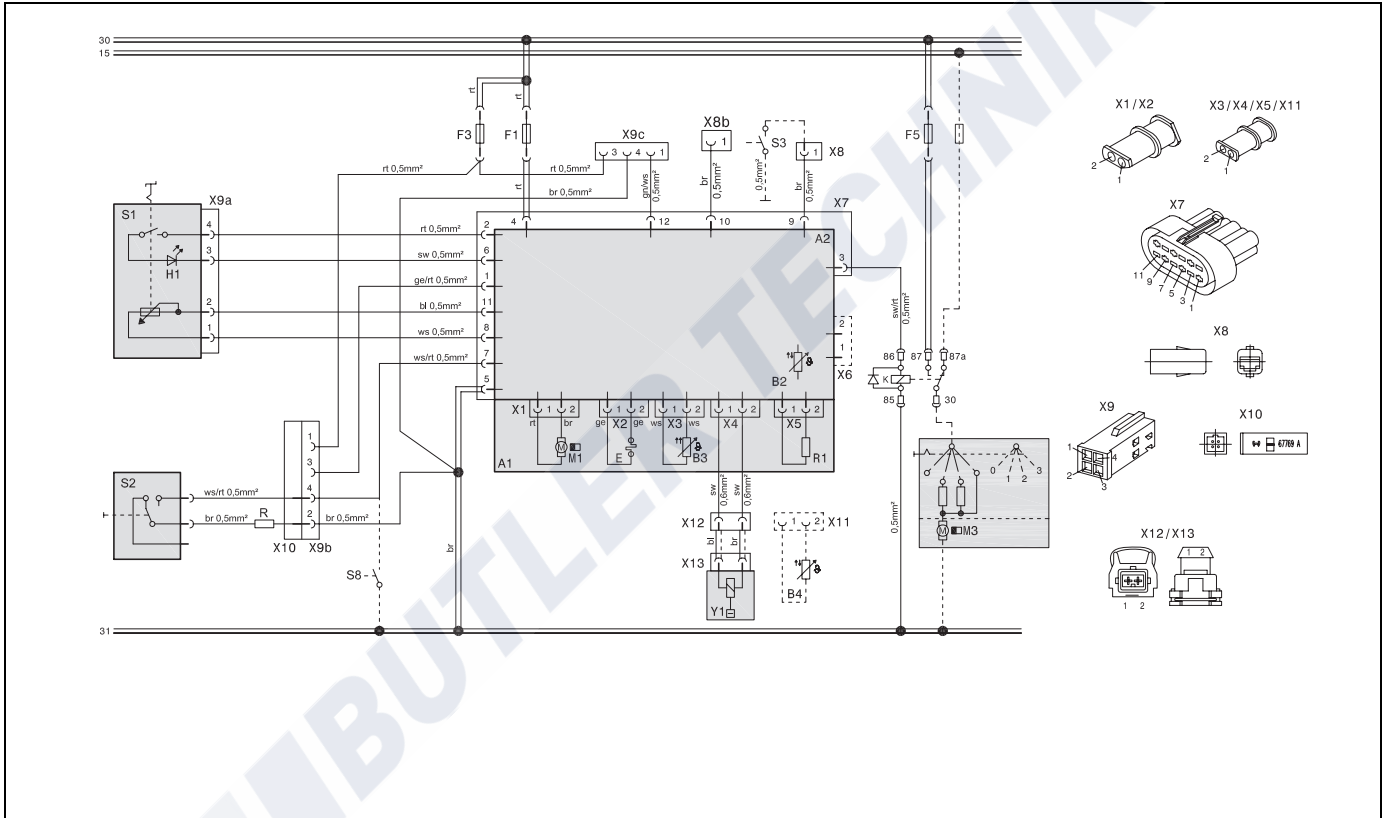
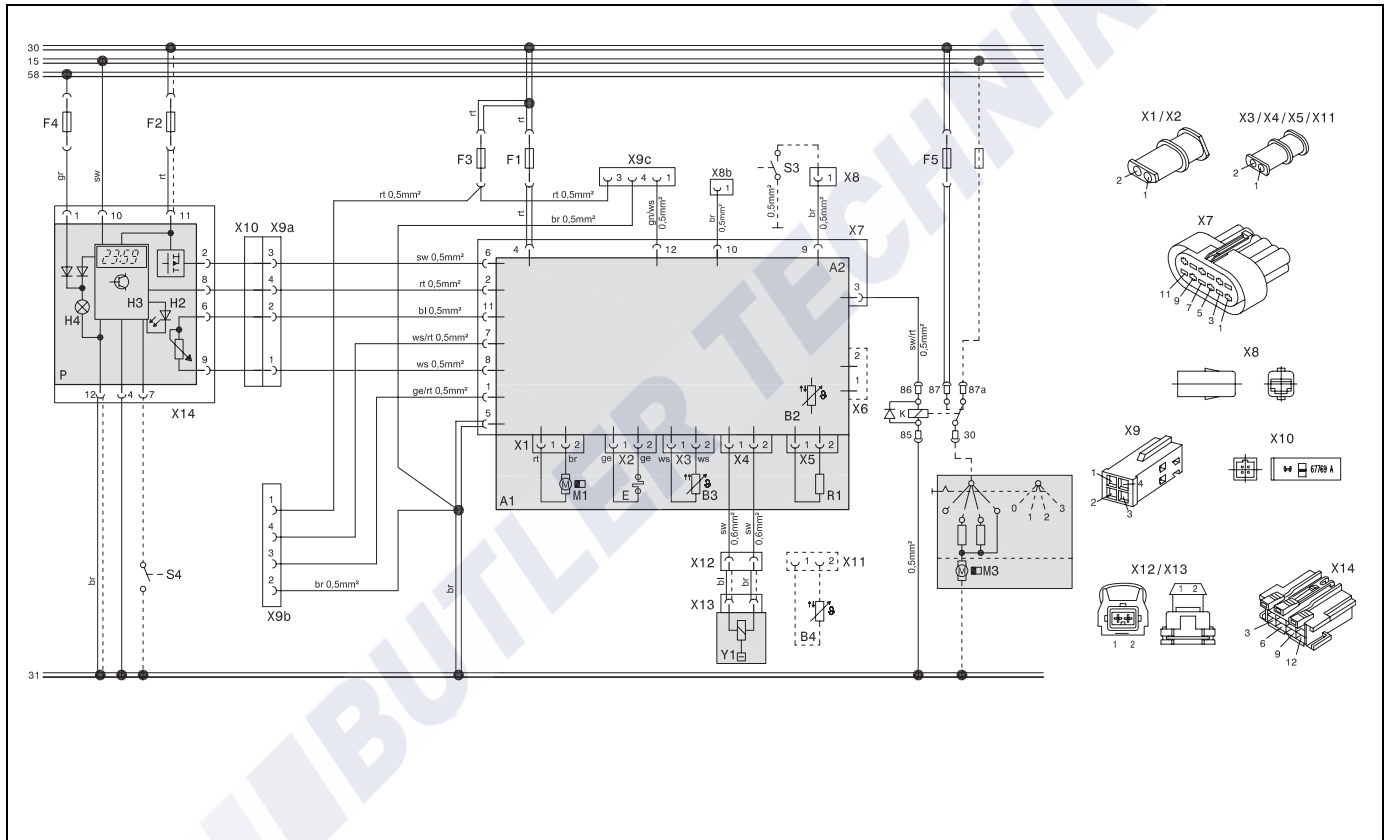

Fig. 33 Connection diagram for Air Top Evo 3900/5500 as system (connection of combination timer 1531 and setpoint generator is also possible)



**Fig. 34** System wiring diagram for the Air Top Evo 3900 and Air Top Evo 5500, 12 V/24 V with control element and vehicle fan, for legend see pages 87 and 88





**Fig. 36** System wiring diagram for the Air Top Evo 3900 and Air Top Evo 5500, 12 V/24 V with combination timer and vehicle fan, for legend see pages 87 and 88

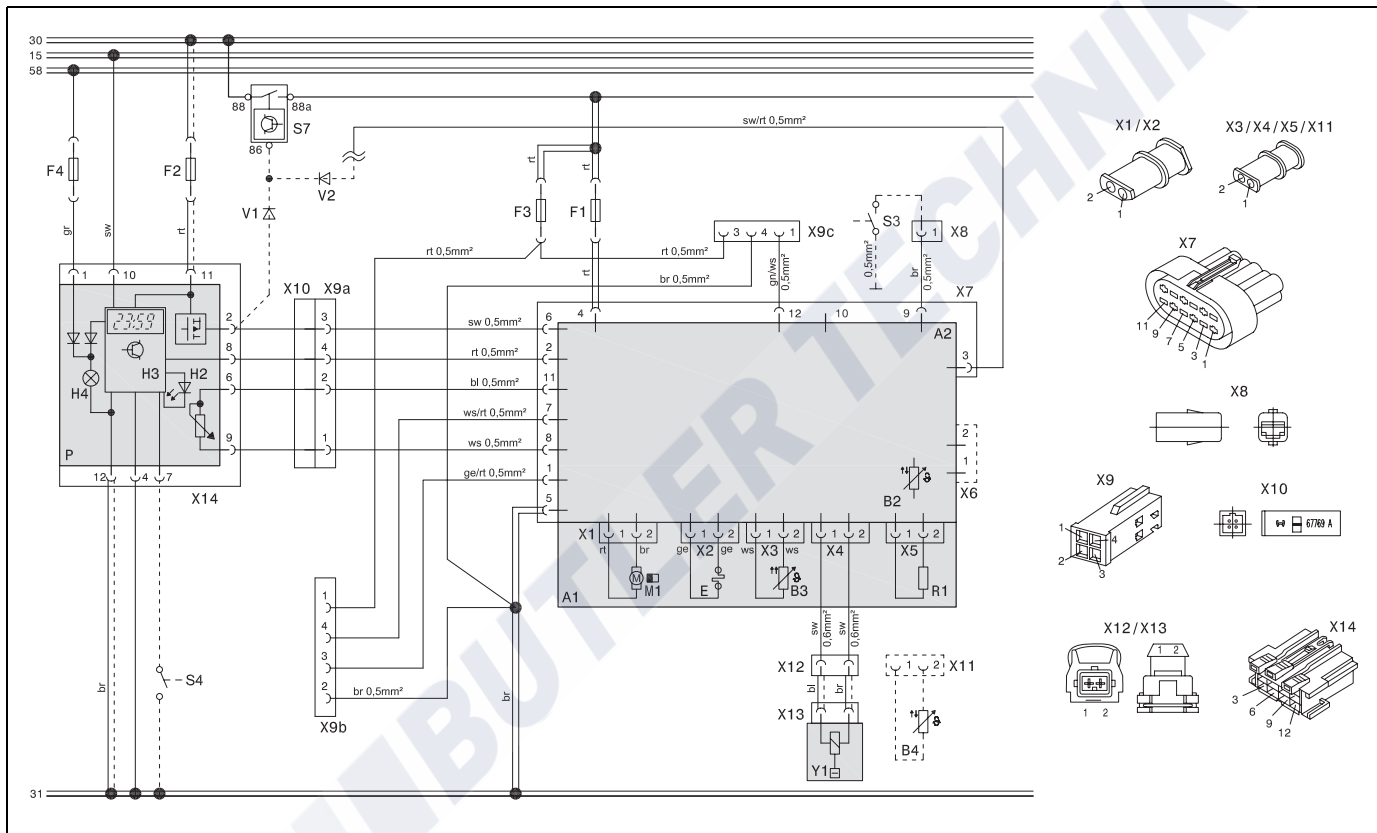
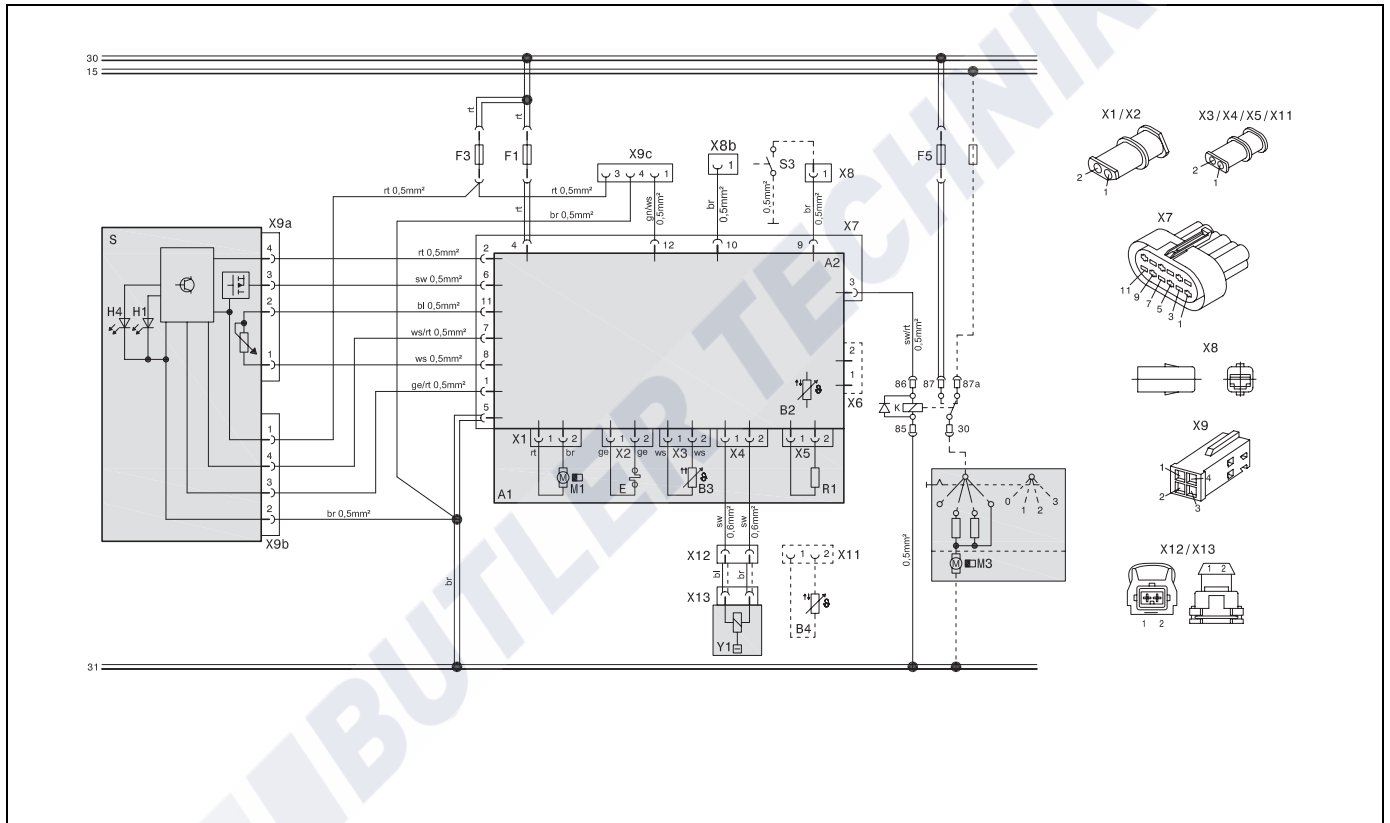

Fig. 37 System wiring diagram for the Air Top Evo 3900 D and Air Top Evo 5500 D, 12 V/24 V with combination timer and electrical battery isolation switch, for legend see pages 87 and 88

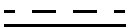





**Fig. 38** System wiring diagram for the Air Top Evo 3900 D and Air Top Evo 5500 D, 12 V/24 V with Control Panel MC04/05 and vehicle fan, for legend see pages 87 and 88





**13 Legend for circuit diagrams**

<b>Cable cross-sections</b>		
	< 7.5 m	7.5 - 15 m
	0.75 mm <sup>2</sup>	1.0 mm <sup>2</sup>
	1.0 mm <sup>2</sup>	1.5 mm <sup>2</sup>
	1.5 mm <sup>2</sup>	2.5 mm <sup>2</sup>
	2.5 mm <sup>2</sup>	4.0 mm <sup>2</sup>
	4.0 mm <sup>2</sup>	6.0 mm <sup>2</sup>

<b>Cable colours</b>	
bl	blue
br	brown
ge	yellow
gn	green
gr	grey
or	orange
rt	red
sw	black
vi	violet
ws	white

Item	Description	Comment
A1	Heater	Air Top Evo 3900/5500
A2	Control module	Control unit 1580
B2	Temperature sensor	Internal
B3	Overheating sensor	Overheating guard
B4	Temperature sensor	External
E	Glow plug / Flame monitor	
F1	Fuse 15 A (24 V) or 20 A (12 V)	Flat fuse SAE J 1284
F2	Fuse 4 A	Blade fuse SAE J 1284 not contained in wiring harness
F3	Fuse 1 A	Flat fuse SAE J 1284
F4	Fuse 4 A	Blade fuse SAE J 1284 not contained in wiring harness
F5	Fuse	Value in [A] to be selected depending on line cross-section
H1	LED green (in item S1)	Indicator
H2	LED red (in item P)	Light in immediate heat button, ready indicator, Switch-on indicator
H3	Heating symbol in the display (in item P)	Indicator
H4	Light bulb/LED (in item P and S)	Display and button lighting
H5	Light bulb/LED	Switch-on indicator pumping device
K	Relay with free-wheeling diode	for vehicle fan
M1	Motor	Combustion and hot air fan
M3	Motor	Vehicle fan
P	Combination timer (1531)	Timer and setpoint generator
R	Resistor	In adapter wiring harness
R1	Resistor 620 Ω	With internal temperature sensor only

Item	Description	Comment
S	Control Panel MC04/05	On/Off switch, setpoint generator and selector switch for additional functions
S1	Basic heater control	On/Off switch and setpoint generator
S2	Switch	Ventilation
S3	Switch	CO <sub>2</sub> setting
S4	Push button	External instant heat button
S5	Switch	Pumping devices/ auxiliary drive
S6	Switch, single or two-pin	Isolation switch
S7	Battery isolation switch	Electronically controlled isolation switch
S8	Switch	Boost (e.g. door contact on ambulance)
X1-X7	Plug connector	on item A2
X8a	Plug connector	to item S3
X8b	Plug connector	Connection of additional heaters via serial bus interface
X9a	Plug connector	on item S or S1
X9b	Plug connector	on item S or S2
X9c	Plug connector	W bus, optional connection of Telemat (12 V) or Thermo Call
X10-X12	Plug connector	
X13	Plug connector	to item Y1
X14	Plug connector	to item P
X15	Plug connector	Connection of additional heaters via serial bus interface
X16	Plug connector	W bus
X17-X18	Plug connector	
Y1	Metering pump	
Y2	Solenoid valve/pump	Pumping devices/ auxiliary drive

## 14 Initial start-up

After you have installed the heater, bleed the fuel supply system carefully.

### NOTE:

As a result of the low fuel consumption the heater must be switched on several times to fill the fuel line.

Until the fuel lines have been filled the heater may switch into a fault lock-out for safety reasons - see chapter 15, "Fault lock-out".

Conduct a trial of the heater to check all the connections for leaks and to ensure that they are secure. If the heater suffers a fault during operation, the fault must be located and remedied.

### 14.1. Initial installation/initial operation of Air Top Evo system

#### Installation

1. Installation of heaters according to the installation instructions
2. The resistor R1 (Fig. 33) must be removed on all slave heaters
3. Ensure that the electrical connections are in accordance with the system wiring diagram (Fig. 34, Fig. 36, Fig. 38)
4. Installation of the heater control and external temperature sensor

### NOTE:

The master heater is only configured as the master if **a heater control** and **an external temperature sensor** is detected.

### Initial start-up

1. Start master heater with controls  
=> Master heater "starts up"
2. Then produce connection between Master and Slave 1 (see system wiring diagram)  
=> Slave 1 heater switches into "Ventilation" state
3. Produce connection from Slave 1 to Slave 2 (see system wiring diagram)  
=> Slave 2 heater switches into "Ventilation" state
4. Teach additional slave heaters (repeat Point 2 and 3)
5. Switch off master heater with heater control  
=> Initial start up completed

### NOTE:

Teaching a slave heater is only possible for a limited time (120 sec)! If this time is exceeded, teaching is no longer possible and the system must be reset (see Workshop Manual).

### 14.2. Resetting Air Top Evo System

If for some reason (communication error, time expired, etc.) teaching has not functioned, it is possible to reset the system to its original state.

1. Switch master heater into "Ventilation" mode
2. De-energise/pull fuse

**NOTE:**

All connected heaters must be disconnected from Terminal 30!

3. Connect voltage and repeat teaching process (see "Initial installation/initial operation").

## 15 Fault lock-out

The control unit has identified errors on individual heater components and faults during the operation.

The heater is shut down (fault lock-out) if:

- No or incorrect start
- Temperature sensor defective
- Overheating sensor interrupt or short circuit
- Overheating sensor installed incorrectly
- Glow plug interrupt or short circuit
- Fan motor overload or blocked or short circuit or interrupt
- Error in the metering pump or overheating guard circuit (start phase only)
- Undervoltage < 10.5 or overvoltage > 16 V, longer than 20 seconds (for 12 V heater)
- Undervoltage < 20.5 or overvoltage > 31 V, longer than 20 seconds (for 24 V heater)
- Control unit defective
- Overheating

The fuel supply is stopped if the heater overheats.

The heater continues to run in the same way as if it is switched off manually.

After it stops the control unit will be set to fault lock-out.

The overheating is indicated by the indicator flashing 10 times.

### **Rectify the cause of the fault.**

To reset the fault switch the heater on and off briefly (at least 2 seconds). If serious faults like overheating or failure to start occur frequently, then the heater will be locked permanently (F12). It can be returned to operation by disconnecting the supply voltage with the heater switched on (e.g. remove fuse and install again).

Repairs must only be carried out by specialist personnel trained by Webasto.

## Fault lock-out

### 15.1. Error code output

#### NOTE:

The error code is output if the heater is fitted with a control element after an error has occurred by the switch-on indicator/error code indicator flashing. After 5 seconds of fast flashing, the error code will be output by a sequence of long flash pulses, the number of flashes is shown in the table below.

If the heater is fitted with a combination timer, an error message will appear on the display of the timer after a fault occurs:

F 00	Control unit error / incorrect parameter set / warm start recognition
F 01	No start / no flame formation
F 02	Flame failure (repeated >3)
F 03	Undervoltage or overvoltage
F 04	Premature flame recognition
F 06	Temperature sensor interrupt or temperature sensor short-circuit
F 07	Metering pump interrupt or metering pump short circuit
F 08	Fan motor interrupt or fan motor short circuit or fan motor overload or fan motor blocked
F 09	Glow plug interrupt or glow plug short circuit
F 10	Overheating
F 11	Overheating sensor interrupt or overheating sensor short circuit
F 12	Heater lock-out
F 14	Overheating sensor incorrect position
F 15	Setpoint generator interrupt

#### Air Top Evo System:

The displayed error codes (F00 - F15) for an Air Top Evo system match an error on the master heater. If an error occurs on the slave heater, only the service code is output (operation indicator flashes with 1 sec. on and 1 sec. off).

## 16 Technical data

Except where limit values are specified, the technical data refer to the usual heater tolerances of  $\pm 10\%$  at an ambient temperature of  $+20\text{ }^{\circ}\text{C}$  and at the rated voltage and in rated conditions.

### 16.1. Electrical components

Control unit, motor, metering pump, lamp in the timer and glow plug / flame monitor are designed for either 12 V or 24 V.

The timer, overheating sensor and temperature sensor component are not dependent on voltage.

### 16.2. Fuel for Air Top Evo 3900 B (petrol) Fuel for Air Top Evo 5500 B (petrol)

The fuel specified by the manufacturer in accordance with DIN EN 228 must be used

### 16.3. Fuel for Air Top Evo 3900 D (diesel) Fuel for Air Top Evo 5500 D (diesel)

The diesel fuel specified by the manufacturer in accordance with DIN EN 590 must be used.

We know of no negative influences due to additives.

If fuel is extracted from the vehicle's tank, follow the additive instructions issued by the vehicle manufacturer.

If you change to low-temperature fuel, the heater must be operated for approx. 15 minutes so that the fuel system is filled with the new fuel.

The Air Top Evo 3900 and Air Top Evo 5500 D heaters are also licensed for use with PME (bio-diesel), which complies with DIN EN 14214 .

Values in brackets apply to the expanded heating capacity "Plus", which can be activated with the MC heater control.

Heater	Operation	Air Top Evo 3900 B	Air Top Evo 5500 B	Air Top Evo 3900 D	Air Top Evo 5500 D
Type test permit		EMC: e1*72/245*2006/96*5529*__ E1 03 5529		(Air Top Evo 3900 / 5500) (Air Top Evo 3900 / 5500)	
		Heater: e1*2001/56*2006/119*0255*__ E1 00 0255		(Air Top Evo 3900) (Air Top Evo 3900)	
		e1*2001/56*2006/119*0256*__ E1 00 0256		(Air Top Evo 5500) (Air Top Evo 5500)	
Model		Air heater with evaporation burner			
Heat output	Control range	1.7 to 3.5 (3.9) kW	1.7 to 5.0 (5.5) kW	1.5 to 3.5 (3.9) kW	1.5 to 5.0 (5.5) kW
Fuel		Petrol EN 228		Diesel/PME EN 590 DIN EN 14214	
Fuel consumption	Control range	0.18 to 0.37 (0.41) kg/h 0.23 to 0.48 (0.54) l/h	0.18 to 0.52 (0.57) kg/h 0.23 to 0.69 (0.75) l/h	0.16 to 0.37 (0.41) kg/h 0.19 to 0.44 (0.49) l/h	0.16 to 0.52 (0.57) kg/h 0.19 to 0.63 (0.69) l/h
Rated voltage		12 V		12/24 V	
Operating voltage range		10.5 to 16 V		10.5 to 16 V/20.5 to 31 V	
Rated power consumption	Control range	15 to 40 (55) W	15 to 95 (130) W	15 to 40 (55) W	15 to 95 (130) W
Permissible ambient temperature:					
Heater	– Operation – Storage	–40 °C to +40 °C –40 °C to +85 °C			
Metering pump	– Operation – Storage	–40 °C to +20 °C –40 °C to +85 °C			
Heater control	– Operation – Storage	–40 °C to +75 °C –40 °C to +85 °C			
Permissible combustion-air intake temperature		–40 °C to +20 °C			



Heater	Operation	Air Top Evo 3900 B	Air Top Evo 5500 B	Air Top Evo 3900 D	Air Top Evo 5500 D
Adjustment range for interior temperature	Control range	+5 °C to +35 °C			
Volume flow of heating air	against 0.5 mbar	max. 132 (139) m <sup>3</sup> /h	max. 200 (220) m <sup>3</sup> /h	max. 132 (139) m <sup>3</sup> /h	max. 200 (220) m <sup>3</sup> /h
CO <sub>2</sub> in exhaust gas (permitted function range)		1.7 kW: 5.0 to 8.0 % 3.5/5.0 kW: 9.0 to 12.5 %		1.5 kW: 6.5 to 8.0 % 3.5/5.0 kW: 9.0 to 12.5 %	
Heater dimensions			Length Width Height	423 ± 2 mm 148 ± 1 mm 162 ± 1 mm	
Heater weight		5.9 kg			



17 Drilling templates

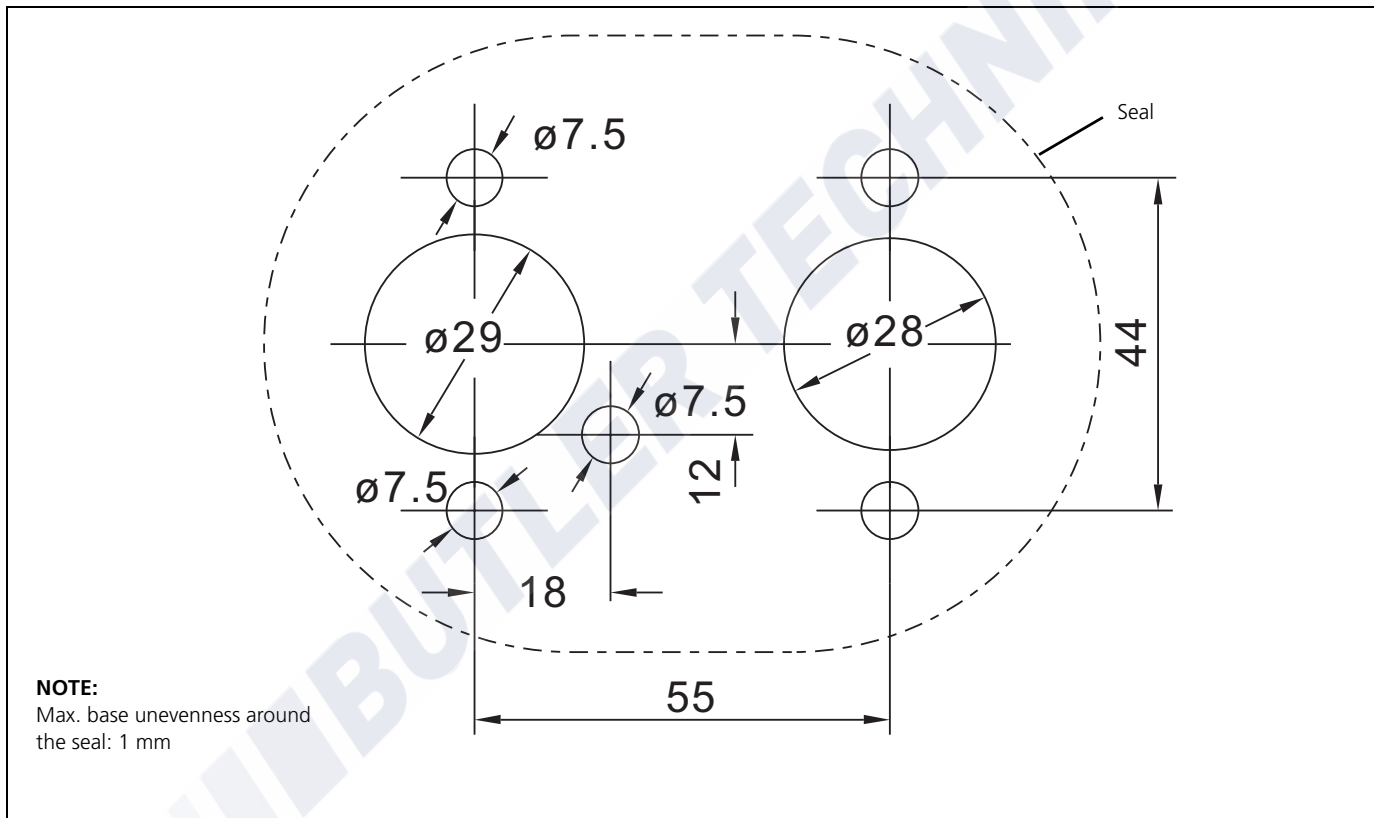

Fig. 40 Heater drilling template



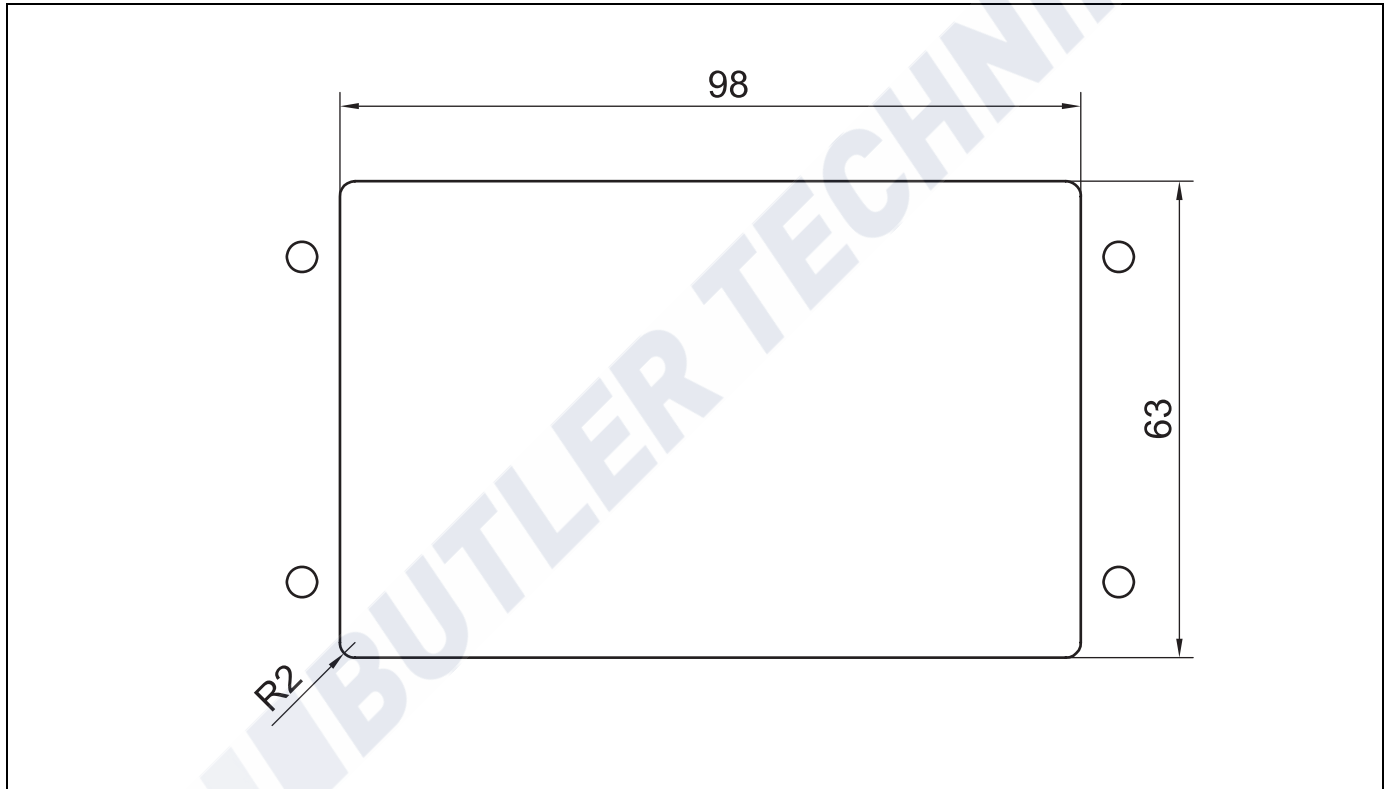

Fig. 41 Drilling Template for Control Panel MC04/05



Im Fall einer mehrsprachigen Version ist Deutsch verbindlich.

In multilingual versions the German language is binding.

Bij een meertalige versie is de Duitse versie bindend.

BT BUTLER TECHNİK

Webasto AG  
Postfach 80  
D - 82132 Stockdorf  
Germany

National:  
Hotline: 01805 93 22 78  
(€0,14 aus dem deutschen Festnetz)  
Hotfax: 0395 5592 353  
Hotmail: [technikcenter@webasto.com](mailto:technikcenter@webasto.com)  
[www.webasto.de](http://www.webasto.de)

International:  
[www.webasto.com](http://www.webasto.com)  
<http://dealers.webasto.com>