

## Air heaters

## Installation instructions

### Air Top 3500 ST

### Air Top 5000 ST

Handelsbezeichnungen / Trade names / Handelsnamen:

Air Top 3500 ST B (Benzin) (petrol) (benzine)

Air Top 3500 ST D (Diesel/PME) (diesel/PME)

Air Top 5000 ST B (Benzin) (petrol) (benzine)

Air Top 5000 ST D (Diesel/PME) (diesel/PME)

04/2004

## Table of contents

1	Statutory regulations governing installation . . . . .	37
2	Use of the air heaters . . . . .	39
3	Installation . . . . .	40
4	Factory plate . . . . .	43
5	Installation example . . . . .	44
6	Hot air system . . . . .	45
7	Fuel supply . . . . .	47
8	Combustion air supply . . . . .	52
9	Exhaust pipe . . . . .	53
10	Combustion air inlet and exhaust lines . . . . .	54
11	Electrical connections . . . . .	56
12	Connection diagram / Circuit diagrams . . . . .	59
13	Legend for circuit diagrams . . . . .	64
14	Starting the heater for the first time . . . . .	66
15	Fault lock-out . . . . .	67
16	Technical data . . . . .	68
17	Version . . . . .	70
18	Drilling template . . . . .	71

BT BUTLER TECHNIK

## 1 Statutory regulations governing installation

The Air Top 3500 ST / Air Top 5000 ST heaters have been type-tested and approved in accordance with EC Directives 72/245/EEC (EMC) and 2001/56/EC (heater) with the following EC permit numbers:

e1\*72/245\*95/54\*1221\*00  
e1\*2001/56\*0021\*00  
e1\*2001/56\*0020\*00

Installation is governed above all by the provisions in Annex VII of Directive 2001/56/EC.

### NOTE:

**The provisions of these Directives are binding within the territory governed by EU Directive 70/156/EEC and should similarly be observed in countries without specific regulations.**

### (Extract from Directive 2001/56/EC Annex VII)

1.7.1. A clearly visible indicator within the user's field of vision must show when the heater is switched on or off.

## 2. Regulations for installation in the vehicle

### 2.1. Scope

2.1.1. Subject to the provisions of paragraph 2.1.2, internal combustion heaters must be installed in accordance with the requirements contained in this Annex.

2.1.2. In the case of class O vehicles (*trailers*) with heaters for liquid fuel, it is presumed that these vehicles comply with the requirements in this Annex.

### 2.2. Position of the heater

2.2.1. Parts of the vehicle body and other components in the immediate vicinity of the heater must be protected against excessive heat and the danger of contamination by fuel or oil.

2.2.2. The internal combustion heater must not pose a fire hazard even when overheated. This requirement is deemed to have been met if care is taken during installation to ensure an adequate distance from all parts, as well as adequate ventilation and if fire-resistant materials or heat shields are used.

2.2.3. For class M<sub>2</sub> and M<sub>3</sub> vehicles the heater must not be installed in the passenger cabin. A device in a sealed cover, which also meets the requirements set out in paragraph 2.2.2, may be used, however.

2.2.4. The plate mentioned in paragraph 1.4 (*model plate*) or a duplicate thereof ( *duplicate model plate*) must be fitted in such a way that it is still clearly legible when the heater has been installed in the vehicle.

2.2.5. When positioning the heater, all reasonable precautions must be taken to minimise the risk of personal injury or damage to items in the vehicle.

### 2.3. Fuel supply

2.3.1. The fuel filler neck must not be located in the passenger compartment and must have a tightly fitting cap to prevent any fuel leaks.

2.3.2. The type of fuel and the fuel filler neck must be clearly identified on heaters for liquid fuel, for which the fuel supply is separate from the fuel supply for the vehicle.

2.3.3. A sign must be affixed to the fuel filler neck warning that the heater must be switched off before refuelling. An identical warning must also be included in the manufacturer's operating instructions.

#### **2.4. Exhaust system**

2.4.1. The exhaust outlet must be positioned in such a way that exhaust fumes cannot get into the interior of the vehicle through ventilation devices, hot-air inlets or open windows.

#### **2.5. Combustion air inlet**

2.5.1. The air for the combustion chamber of the heater must not be extracted from the passenger cabin of the vehicle.

2.5.2. The air inlet must be positioned in such a way that it cannot be obstructed by other objects.

#### **2.6. Hot air inlet**

2.6.1. The supply of heating air must consist of either fresh air or recirculated air and must be taken from a clean area which cannot be contaminated by exhaust fumes from the engine, the internal combustion heater or any other source in the vehicle.

2.6.2. The inlet line must be protected by a grating or other suitable means.

#### **2.7. Hot air outlet**

2.7.1. Hot air lines within the vehicle must be positioned or protected in such a way as to exclude all risk of injury or damage caused by direct contact.

2.7.2. The air outlet must be positioned or protected so that it cannot be obstructed by other objects.

#### **2.8. Automatic control of the heating system**

When the engine stops, the heating system must cut out automatically and the fuel supply must be stopped within 5 seconds. The heating system may remain in operation if a manual unit has already been activated.

#### **IMPORTANT**

Failure to follow the installation instructions and the notes contained therein will lead to all liability being refused by Webasto. The same applies if repairs are carried out incorrectly or with the use of parts other than genuine spare parts. This will result in the invalidation of the type approval for the heater and therefore of its **homologation / EC type licence**.

#### **NOTE:**

For vehicles with an EU permit, no entry in accordance with § 19 Sub-Section 4 of Annex VIII b to the Road Traffic Act is required.

## **2 Use of the air heaters**

The Webasto Air Top 3500 ST and Air Top 5000 ST air heaters are designed

- to heat cabins, boats, trucks, minibuses, vans, ambulances and motorhomes
- to defrost vehicle windows
- to heat cargo

The heaters operate independently of the engine and are connected to the fuel tank and the electrical system of the vehicle.

They may be used for vehicles with either water or air-cooled engines.

They are not designed for heating hazardous substances.

# Installation

## 3 Installation

### IMPORTANT

The statutory regulations governing installation on pages 1 and 2 must be adhered to. The requirements of the latest version of the ADR must also be observed for the installing the heater into vehicles used to transport hazardous substances. The heater must not be operated without the control unit cover (this will cause the heater to overheat).

### 3.1. Air Top 3500 ST / Air Top 5000 ST installation situation

#### NOTE:

Check the installation situation of the relevant vehicle type.

### 3.2. Installation location

The heater may be fitted both in the interior or on the exterior of the vehicle. If it is installed on the exterior ensure that the heater is fitted in a position where it is protected from splashing water and spray.

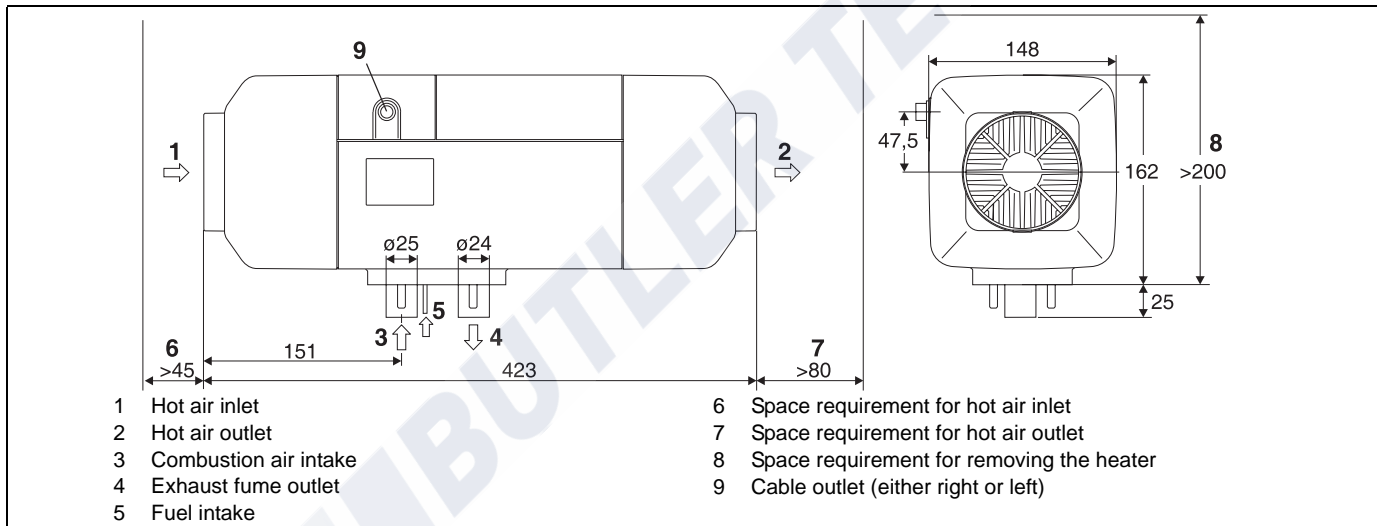

Fig. 1: Dimensions of the heater

The heater must be installed in such a way that no water can ingress into it if the vehicle travels through a water hazard for which that vehicle is licensed.

The openings for the combustion air inlet port, the exhaust outlet port and the fuel pipe must be sealed if the heater is installed in the interior. The seal designed and supplied for this purpose must be used (see Figure 4).

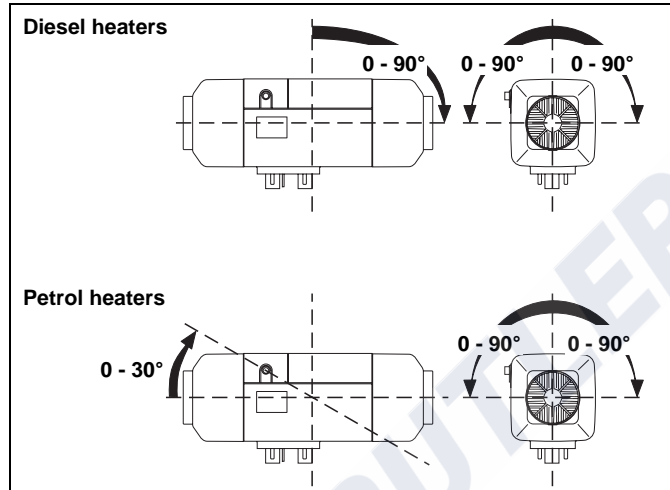

Fig. 2: Possible installation locations

### 3.3. To install the heater

The M6 nuts must be tightened with a torque of 6 Nm +1 Nm for installing the Air Top 3500 ST or Air Top 5000 ST heater.

The installation dimensions and space requirement for service access are shown in the installation drawing (Figure 1). The specified horizontal and axial angles must not be exceeded (Figure 2).

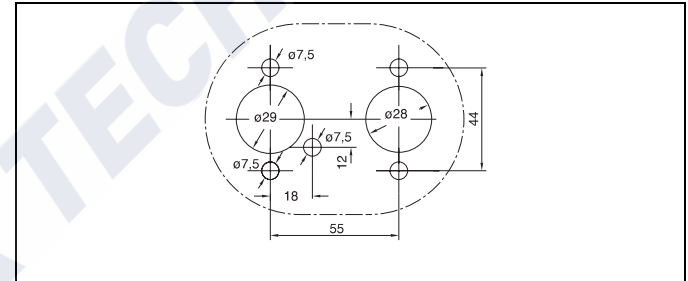

Fig. 3: Hole pattern

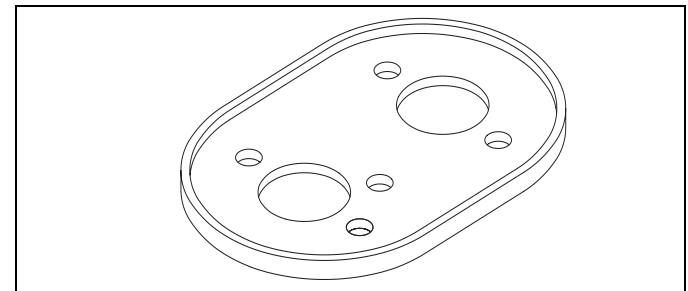

Fig. 4: Seal



## Installation

A seal (Figure 4) must be fitted between the heater and the vehicle body. **This seal must be replaced each time the heater is installed.** The support area for the heater foot **must be flat**. A special tools can be purchased from Webasto to drill the holes and, if necessary, smooth the support area. The seal can compensate for unevenness of max. 1 mm.

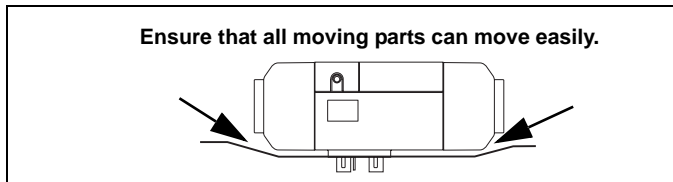

Fig. 5: Installation

### IMPORTANT

After installation, check that the casing is not in contact with any parts of the vehicle body. A failure to do this may result in the hot air fan blocking.

#### **4 Factory plate**

The model plate must be positioned so that it cannot be damaged and must be clearly legible when the heater is installed (otherwise a duplicate model plate must be used).

Inapplicable years must be erased from the model plate.



5 Installation example

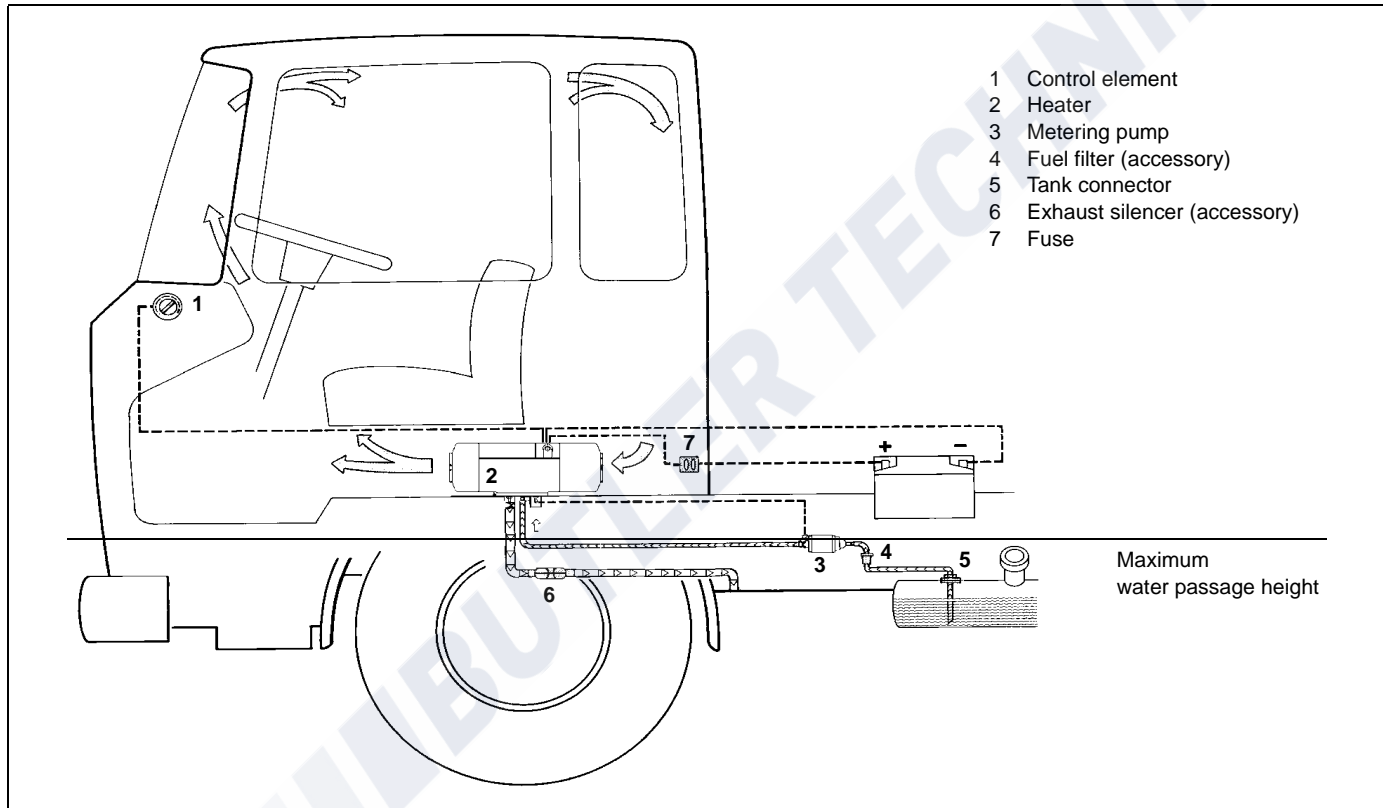

Fig. 6: Installation example for air heater in recirculation mode

## 6 Hot air system

### NOTE:

The heater must not be integrated into the vehicle's air system.

Both recirculation and fresh air modes are possible.

For fresh air mode it must be ensured that the hot air is taken from an area protected from splashing water and spray and in such a way that no water can ingress into the heater if the vehicle travels through a water hazard for which that vehicle is licensed.

### NOTE:

For fresh air mode an external temperature sensor must be fitted in the appropriate zone. The standard pause speed is 0 rpm if the external temperature sensor is used.

Inside the control unit there is a temperature sensor, which operates the heater in the appropriate heat output range in conjunction with the control element depending on the intake temperatures and the position of the setpoint generator. The heat output is controlled such that after the selected interior temperature has been reached quickly, it is then kept at this selected value.

Recommended internal diameter of the main section of the **hot air line**:

90 mm for the Air Top 5000 ST

80 mm for the Air Top 3500 ST

### NOTE:

Only materials that can permanently withstand temperatures of at least 130 °C may be used for the hot air line. The hot air opening is to be positioned in such a way that the air is not blown on to any parts that cannot withstand the heat.

### IMPORTANT

In vehicles used to transport people, the air outlet opening is to be directed in such a way that it is at least 20 cm away from all body parts.

Maximum pressure drop between the inlet and outlet side of the hot air line:

Air Top 3500 ST 2.0 hPa

Air Top 3500 ST Volume Plus 3.0 hPa

Air Top 5000 ST 3.0 hPa

1 hPa corresponds to 1 mbar corresponds to 10 mm WC.

The heaters check the internal temperature rise automatically each time they are switched on. If this is above the specified limits, the start is cancelled and error messages F10 is displayed. To ensure that the heater functions stably, the flow resistance of the connected hot air system must be reduced.

The points table for air guide parts in the Webasto catalogue may be used to design the hot air system.

The hot air hose must be secured at its connection points.

If the heater is used in recirculation mode without a hot air guide, do not short circuit the hot air flow.

### IMPORTANT

If you use the heater without a hot air inlet hose, the inlet grille supplied with the heater must be used at all times.

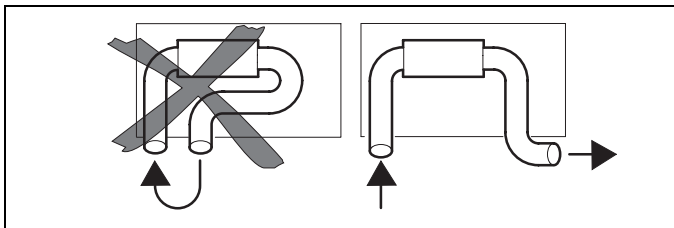

Fig. 7: Hot air inlet and hot air outlet

**NOTE:**

The installation must be checked for:

- Air short circuit between the vehicle's heating system and the heater air inlet
- Air short circuit between the heater's air inlet and the heater's air outlet (Figure 7)

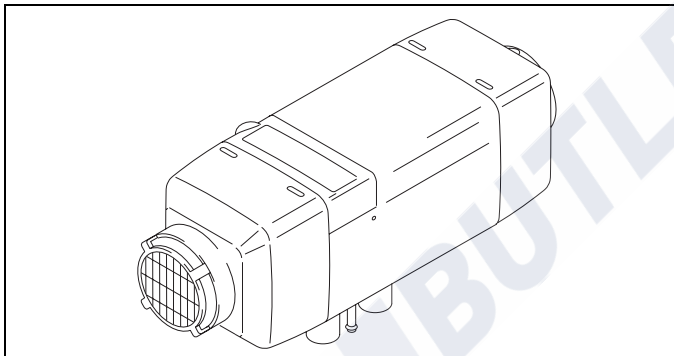

Fig. 8: Hot air inlet with inlet grille

If you use an installation box the air vent must be sealed in such a way that no hot air can get into the installation box.

**6.1. External temperature sensor**

The installation of an external temperature sensor is recommended if the heater is operated in fresh air mode.

**6.1.1. To install the external temperature sensor**

The external temperature sensor must be installed at medium height in the passenger cabin on vertical surfaces if possible in the area that requires heating.

The temperature sensor must **not**

- be in the direct current of hot air (from the vehicle's own heating system or the hot air heater).
- be close to heat sources (for example the vehicle's own heating system).
- be placed in direct sunlight (for example on the dashboard).
- be installed behind curtains or the like.

## 7 Fuel supply

The fuel is taken from the vehicle fuel tank or from a separate fuel tank. The values for the maximum pressure at the fuel extraction point are shown in Figure 9.

Permissible fuel inflow height H (m)	At max. pressure (bar) in fuel line
0.00	0.2
1.00	0.11
2.00	0.03
Maximum fuel intake height S (m)	At max. negative pressure (bar) in the fuel tank
0.00	-0.10
0.50	-0.06
1.00	-0.02

Only for ADR: The statutory regulation of ADR (Accord européen relatif au transport international des marchandises dangereuses par route) governing fuel tanks, part 9 para. 9.2.4.7, must be adhered to.

A sign must be affixed to the fuel filler neck warning that the heater must be switched off before refuelling.

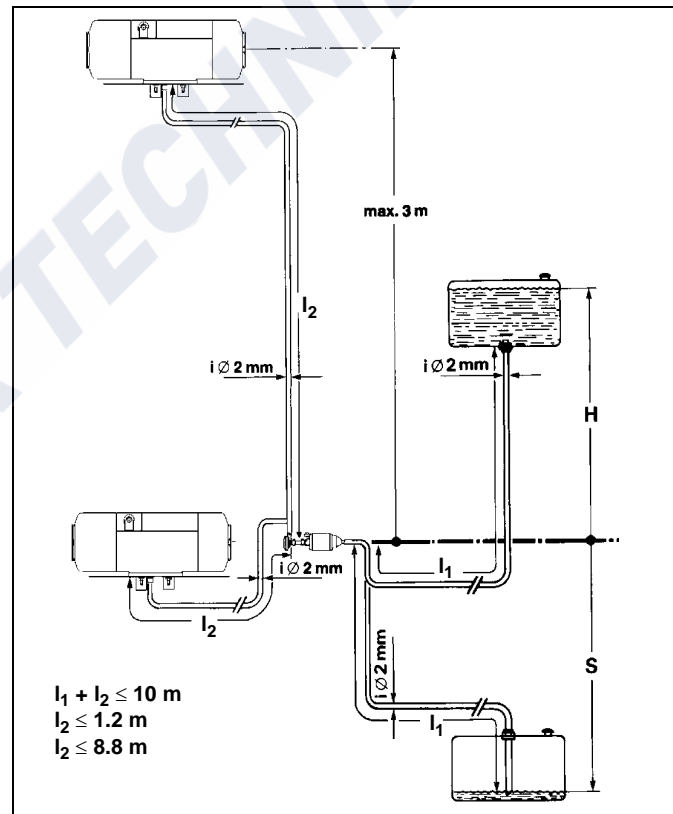

Fig. 9: Fuel supply

# Fuel supply

## 7.1. Vehicles with carburettor engines

The fuel may only be extracted using the special Webasto fuel extractor (see Figure 10) as close to the tank as possible. The connect may be made in either the supply or return line, in which case the return line must lead almost to the base of the tank (see Figure 11).

The fuel extractor must be fitted in such a way that any air or gas bubbles are automatically discharged towards the tank (see Figure 10).

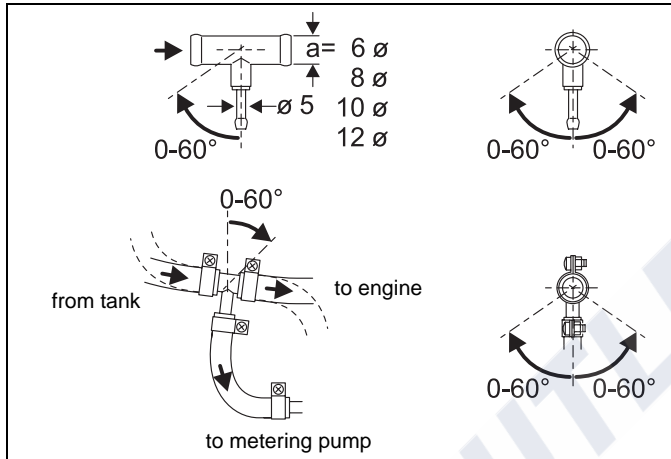

Fig. 10: Webasto fuel extractor

The fuel extractor should not be located near the engine, as gas bubbles may form in the lines on account of heat radiated from the engine. This may cause problems during combustion.

## 7.2. Vehicles with injection engines

When installing the heater in a vehicle with fuel injection system, it is important to establish whether the fuel pump is located inside or outside the tank.

If the fuel pump is located inside the tank, fuel can only be extracted from the return line using the Webasto fuel extractor (see Figure 11), in which case it must be ensured that the return line continues almost to the bottom of the tank (see Figure 11 for details of the minimum distance from the bottom of the tank). If this is not the case Webasto fuel extractor (see Figure 11, 12 and 13) may be used.

If the fuel pump is installed outside the tank, the fuel connection may also be made between the tank and the fuel pump, again using only the Webasto fuel extractor (see Figure 10).

## 7.3. Vehicles with diesel engines

The fuel must be taken from the vehicle fuel tank or from a separate tank (see Figs. 11, 12 and 13). This separate fuel pickup precludes any effect of pressure.

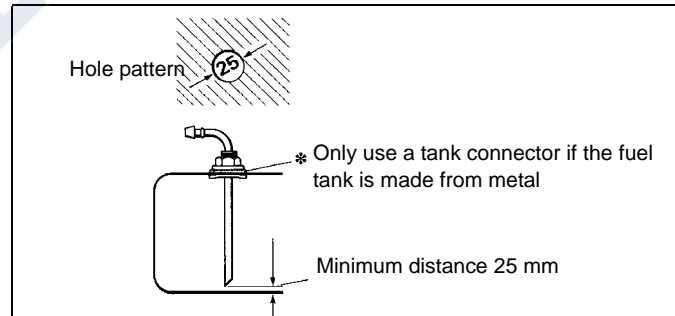
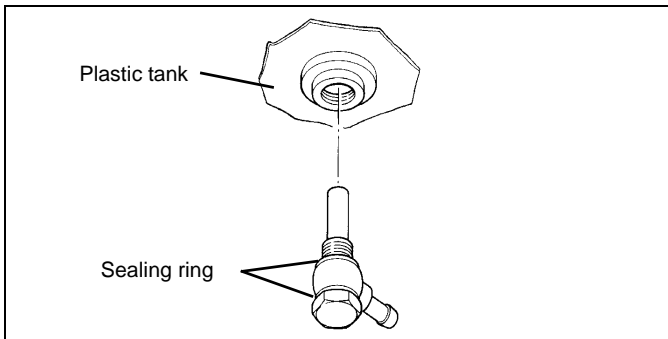
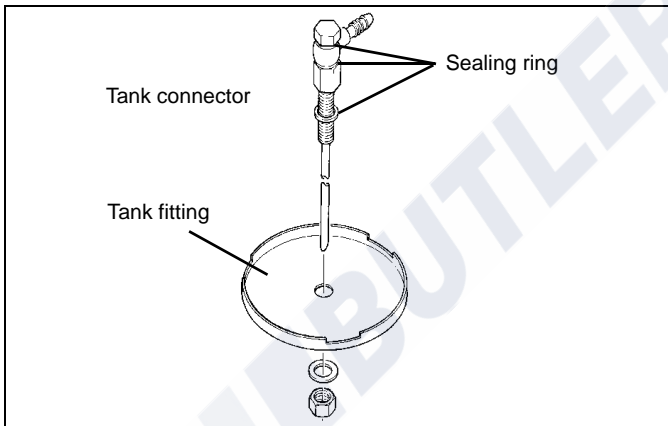

Fig. 11: Webasto tank connector



**Fig. 12: Fuel pickup from the plastic tank**  
(Pickup via tank drain screw)



**Fig. 13: Fuel pickup from the plastic tank**  
(Pickup via tank fitting)

**NOTE:**

The tank fitting must be made from metal!

**7.4. Fuel lines**

Only steel, copper and plastic lines of plasticised, light and temperature-stabilized PA 11 or PA 12 (e.g. Mecanyl RWTL) pursuant to DIN 73378 may be used for the fuel lines. Since the lines normally cannot be routed with a constant rising gradient, the internal diameter must not be allowed to exceed a certain size. Air or gas bubbles will accumulate in lines with an internal diameter of more than 4 mm and these will cause malfunctions whilst the heater is operating if the lines sag or are routed downwards. The diameters specified in Figure 9 will ensure that bubbles do not form.

The lines should not be routed downwards from the metering pump to the heater.

Unsupported fuel lines must be secured to prevent them sagging. They must be installed in such a way that they cannot be damaged by flying road chippings and high temperatures (exhaust line). The fuel lines must be secure at the connections using hose clips to prevent their slipping.



### 7.4.1. Connecting two pipes with a hose

The correct procedure for connecting fuel lines with hosing is shown in Figure 14.

Ensure that there are no leaks.

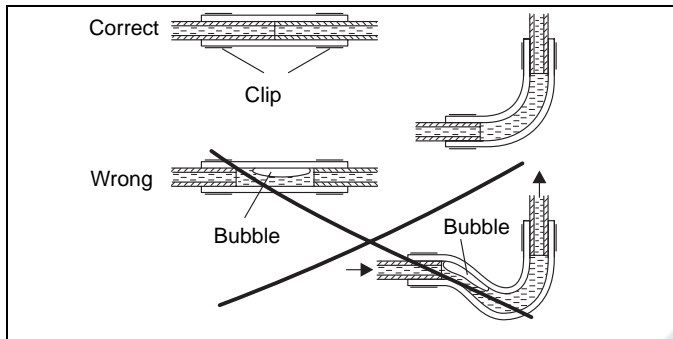

Fig. 14: Pipe / hose connection

### 7.5. Metering pump

The metering pump is a combined delivery, metering and shut-off system and is subject to certain installation criteria (see Figures 9, 15 and 16).

#### 7.5.1. Installation location

The metering pump must be installed in a cool place as close as possible to the tank (see Figure 9). The maximum ambient temperature must not exceed +20 °C for petrol heaters at any time during operation.

The metering pump and fuel lines must not be installed within range of the radiated heat from hot vehicle parts. A heat shield must be used if necessary.

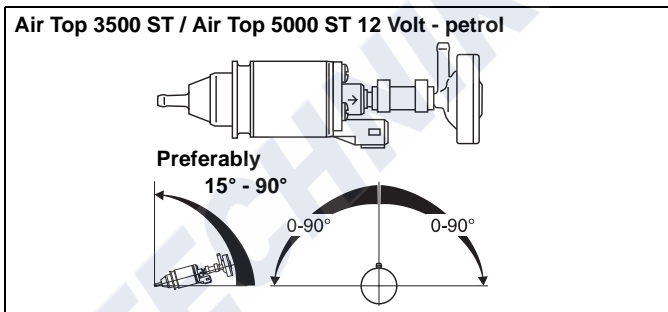

Fig. 15: Metering pump DP 2  
Installation position

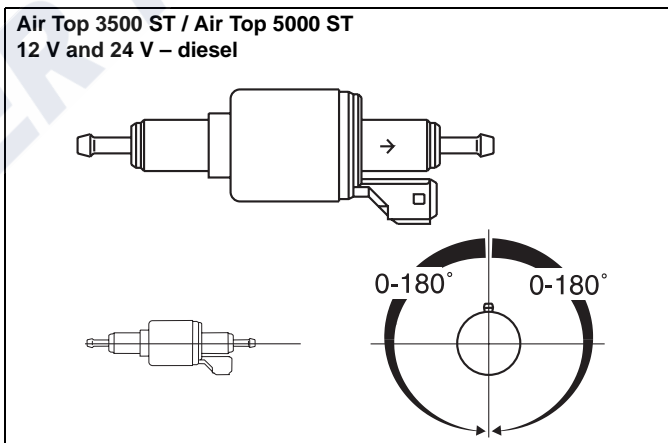

Fig. 16: Metering pump DP 30.2/30.3  
Installation position

**7.5.2. Installation and attachment**

The metering pump must be secured with a vibration-damping mounting (for example a rubberised clip). Its installation position is limited as shown in Figures 15 and 16 in order to ensure effective automatic bleeding.

As a result of the risk of corrosion, only genuine Webasto parts may be used for the plug connections between the metering pump and the metering pump wiring harness.

**7.6. Fuel filter**

Only a Webasto filter, order no. 487 171, is allowed to be used if the fuel is expected to be contaminated. Install vertically if possible, however at least horizontally (check flow direction).

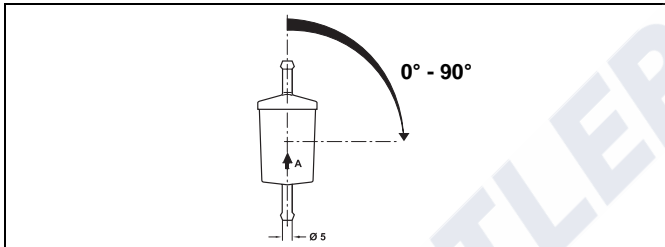

**Fig. 17: Air Top 3500 ST and Air Top 5000 ST fuel filter**

## **8 Combustion air supply**

Under no circumstances may the combustion air be taken from areas occupied by people. The combustion air intake opening must not point in the direction of travel. It must be located so that it cannot become clogged with dirt.

**NOTE:**

An intake silencer must be fitted if the intake hose length is greater than 0.6 m.

**NOTE:**

The combustion air must be extracted using a combustion air line from a position that is as cool as possible and protected from splashing water. Do not use an exhaust line as the combustion air line since otherwise the metering pump cable from the combustion air inlet port may be damaged. The combustion air opening must not be under the minimum water drive-through level permitted for the vehicle.

See the statutory regulations for the installation for further regulations.

## 9 Exhaust pipe

Rigid pipes of unalloyed or alloyed steel with a minimum wall thickness of 1.0 mm or flexible piping of alloyed steel only must be used as exhaust line. The exhaust pipe is secured to the heater using a clamping collar, for example. See the statutory regulations for other requirements.

The exhaust silencer should ideally be installed near the heater. The heater may also be operated without a silencer.

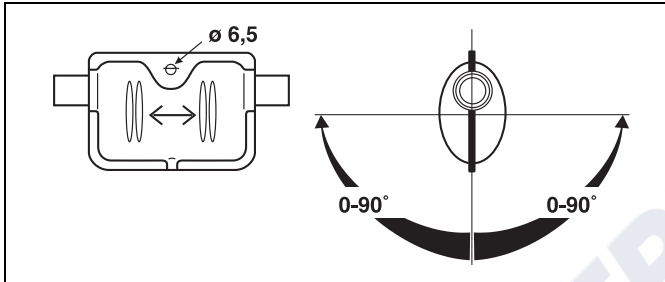

**Fig. 18: Exhaust silencer**  
Arbitrary flow direction

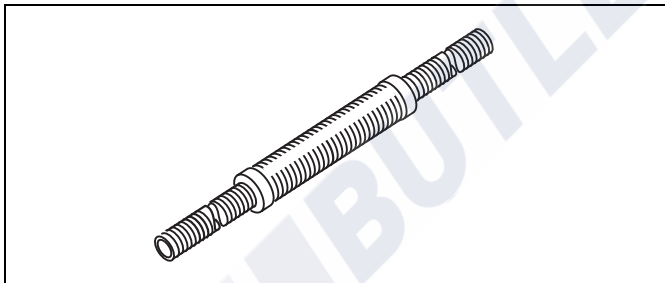

**Fig. 19: Exhaust silencer for boat applications**  
Flow direction and installation position arbitrary

## 10 Combustion air inlet and exhaust lines

Both lines are to be installed falling away from the heater. If this is not possible, a condensate drain hole with a diameter of 4 mm must be made at its lowest point.

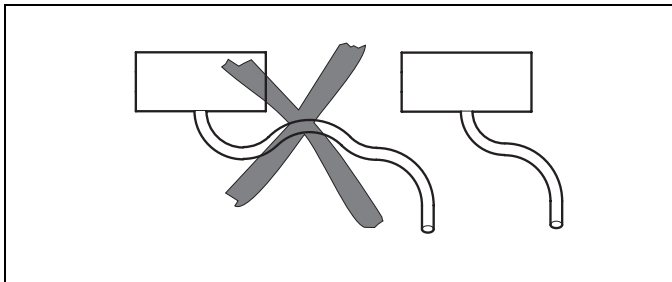

**Fig. 20: Prevent the formation of condensate**

The lines must not point to the front of the vehicle.

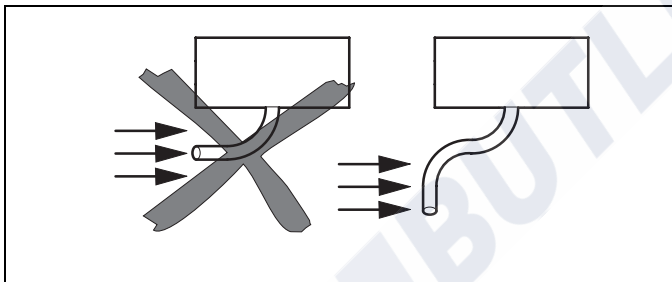

**Fig. 21: The lines must not end pointing towards the front of the vehicle**

The lines must be located so that they cannot become clogged with dirt.

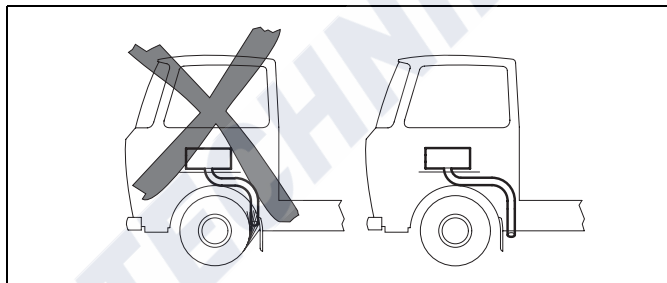

**Fig. 22: Avoid the lines becoming clogged with dirt**

### IMPORTANT

If the exhaust pipe ends is other than as shown in the Figure 23 it will pose a fire risk.

Length of the combustion air inlet and exhaust lines in total:

With exhaust silencer: max. 2.0 m

Without exhaust silencer: max. 5.0 m

### NOTE:

If the exhaust line is over 2 m in length the lines must be insulated (to prevent falling below the dewpoint)

Internal diameter of the lines:

Combustion air line: 25 mm

Exhaust line (metal): 24 mm

Minimum bending radius: 50 mm

Total bends:

Combustion air line: max. 270°

Exhaust line: max. 270°

An attachment is required no further than 150 mm from the end of the exhaust pipe to ensure that the angle of  $90^\circ \pm 10^\circ$  is achieved

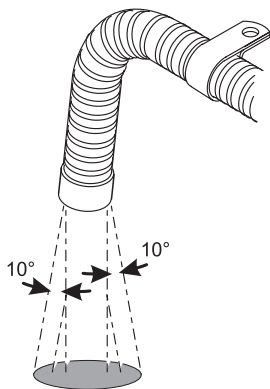

Discharge direction almost vertical  $90^\circ \pm 10^\circ$

**Fig. 23: Exhaust pipe opening**  
Installation position

Only for ADR: The statutory regulation of ADR (Accord européen relatif au transport international des marchandises dangereuses par route) governing the routing of the exhaust line, part 9 para. 9.2.4.7, must be adhered to.

## Electrical connections

### 11 Electrical connections

All lines that are not required must be insulated at their free end.

#### NOTE:

If the combination or standard timer is used, a touch-sensitive switch may be installed in the sleeping section to act as a remote control and improved convenience. The connections must be made as shown in the circuit diagrams in Figures 32 and 33.

The electrical connection is made as shown in the system circuit diagram (Figures 31, 32, 33 and 34).

#### 11.1. Connection for installing the heater in a hazchem vehicle (ADR)

To install the Air Top 3500 ST D and Air Top 5000 ST D heaters in hazchem vehicles, the requirements of ADR/RID part 9 para. 9.2.4.7 – Combustion heating systems, must also be satisfied. The electrical connection is made as shown in the circuit diagram in Figure 34.

#### NOTE:

The switch S3 must be installed in such a way that a positive potential is connected to appropriate input of the control module when a pumping device is switched on.

#### IMPORTANT

All ADR functions are ineffective if there is no earth at control unit input X6/1 when the system is switched on. The control unit continues to run briefly for a maximum of 40 seconds and then switches to "fault lock-out" operating mode when a positive voltage is connected to control unit input X6/1 (auxiliary power take-off on) or the engine is switched off.

#### IMPORTANT

In accordance with the regulations of the act governing the road/rail haulage of hazardous materials, heaters are only allowed to be taken into service with a special manually operated switch fitted in the cab. If the system is equipped with a combination timer, ensure that contact 4 on the combination timer remains free. The heater can then only be taken into service using the immediate heat button. The use of other timers in ADR vehicles is not permitted.

#### 11.2. Heater connection

To connect the wiring harness, remove the control unit cover on the heater and connected the wiring harness plug to the control unit.

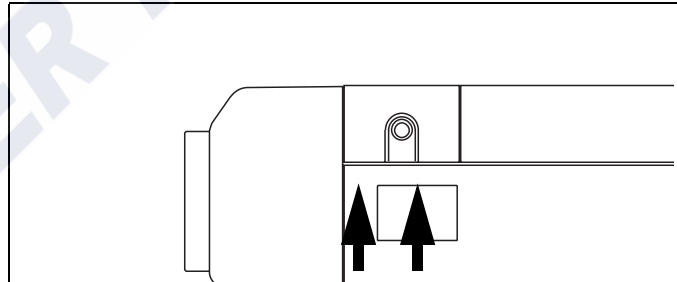

Fig. 24: To remove the control unit cover

#### NOTE:

Raise the control unit cover on both sides using a blunt blade (Figure 24 arrows).

Before using the heater for the first time fit the control unit cover to prevent the illegal escape of hot air (heater overheating).

The cable passage can be placed at either the left or right side. To ensure that the cable passage in the control unit cover seals perfectly, the cable grommet is to be adjusted appropriately on the wiring harness.

### 11.3. Supply voltage connection

Ideally from the vehicle's central electrical system.

**An additional blade terminal fuse holder is to be fitted to protect the heater (supplied with the heater). The fuse holder may only be installed in the interior of the vehicle.**

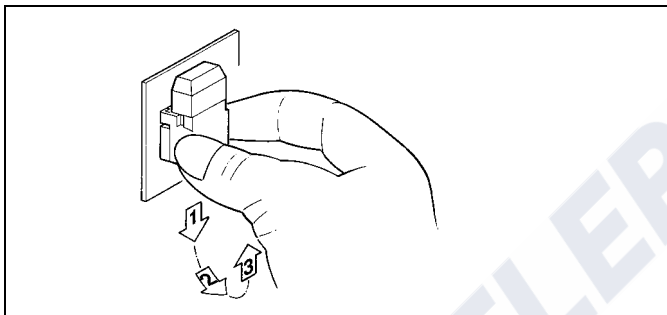

Fig. 25: Remove the fastening plate on the fuse holder

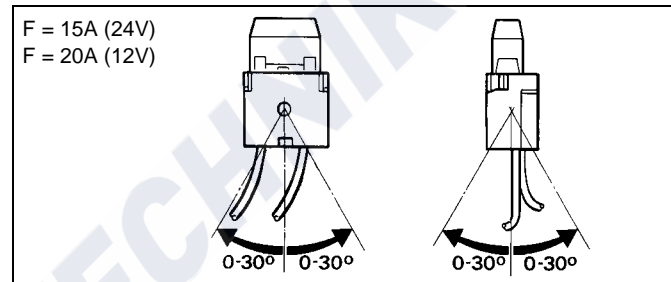

Fig. 26: Fuse holder, installation position



## Electrical connections

### 11.4. Control element connection

The wiring harness is prepared for connection to the control element. Simply pull on connector housing to unplug the connector. The connector housing can be locked (self-locking action) by simply pulling on the wiring harness.

**NOTE:**

The fibre optic cable must be in contact with the rotary knob

**NOTE:**

As an option an external temperature sensor may be installed in the passenger cabin (see page 46).

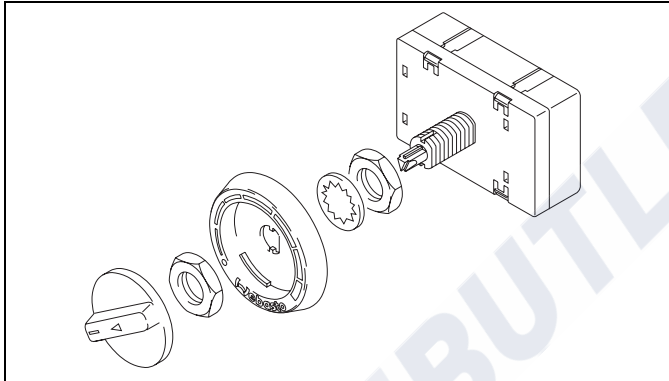

Fig. 27: Control element

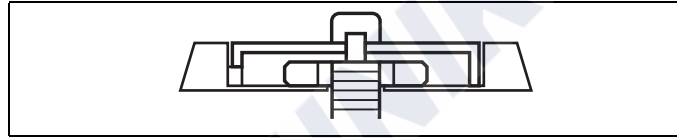

Fig. 28: Installation of the control element

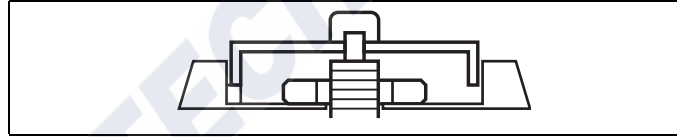
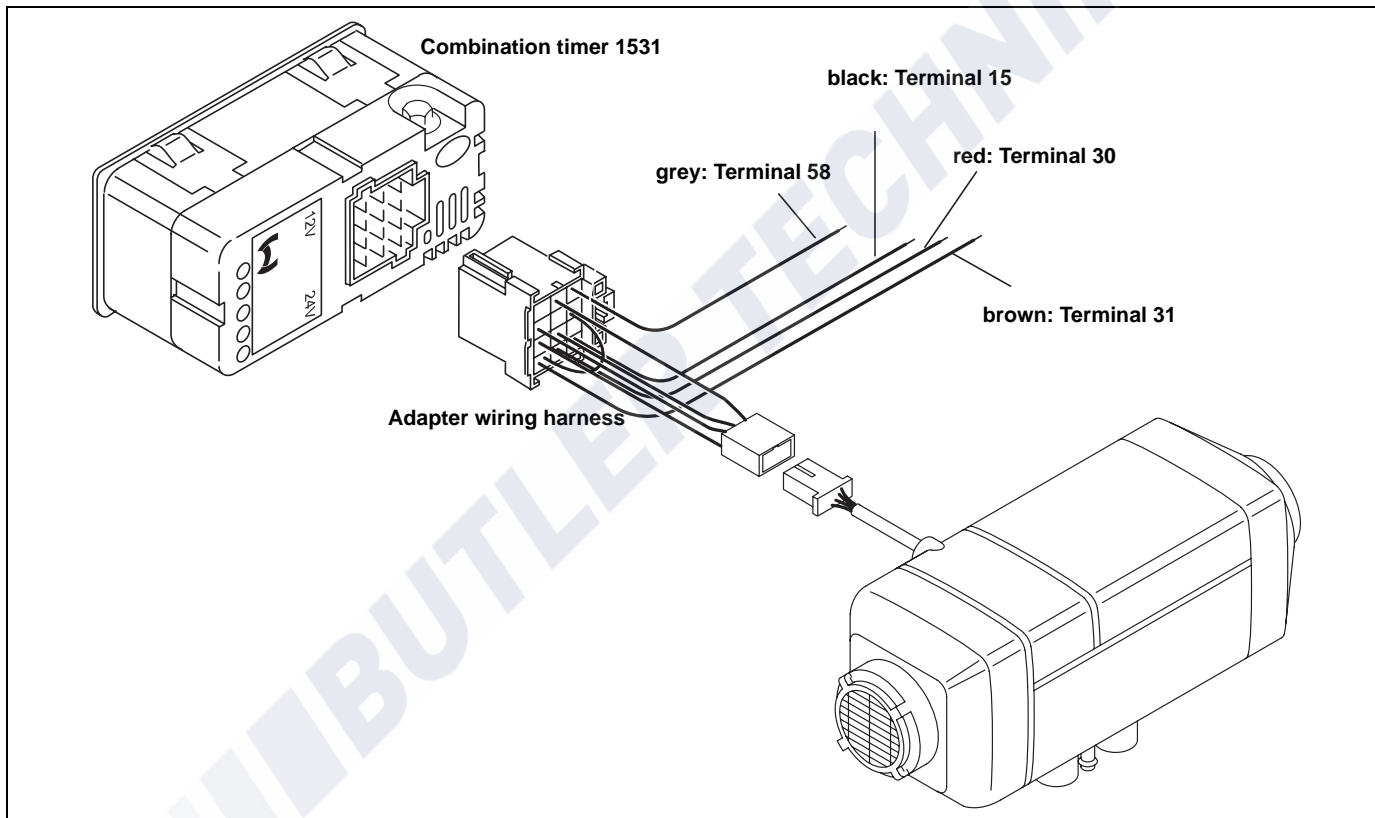

Fig. 29: Installation of the control element (incorrect)

**12 Connection diagram / Circuit diagrams**



**Fig. 30: Air Top 3500 ST and Air Top 5000 ST with combination timer connection diagram**

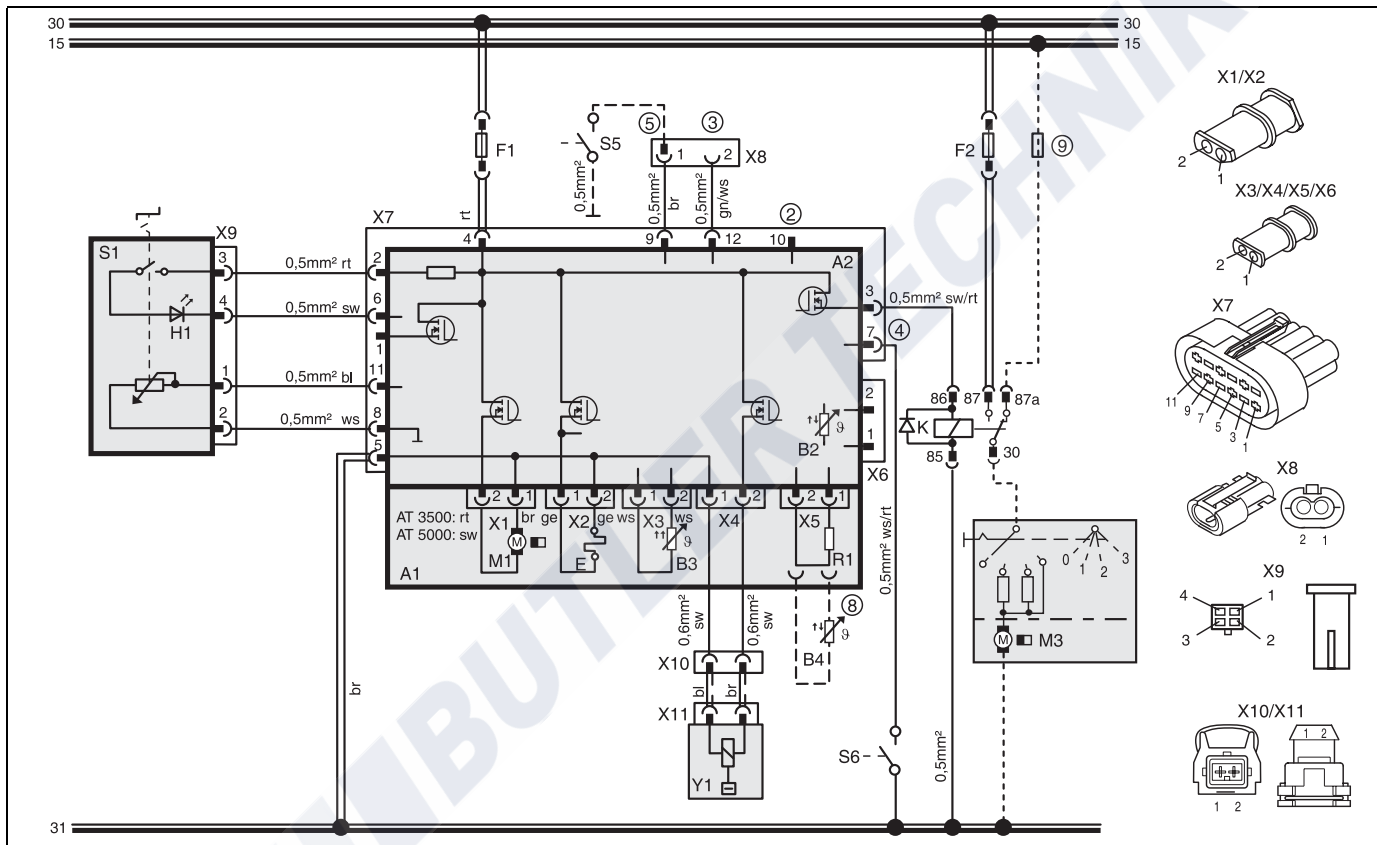
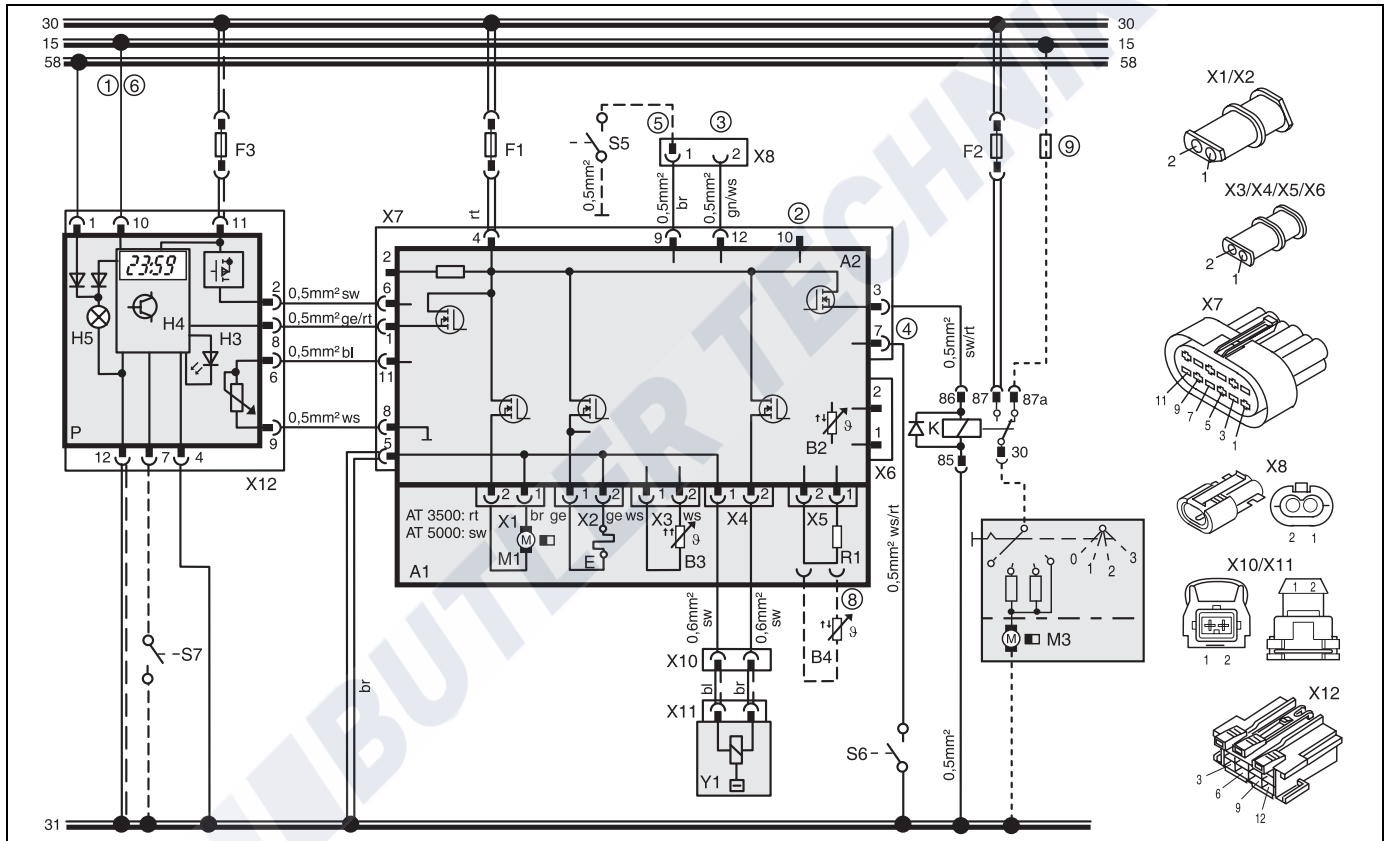

Fig. 31: System wiring diagram for the Air Top 3500 ST and Air Top 5000 ST, 12V/24V with control element and vehicle fan, for legend see pages 64 and 65



**Fig. 32: System wiring diagram for the Air Top 3500 ST and Air Top 5000 ST, 12V/24V with combination timer and vehicle fan, for legend see pages 64 and 65**

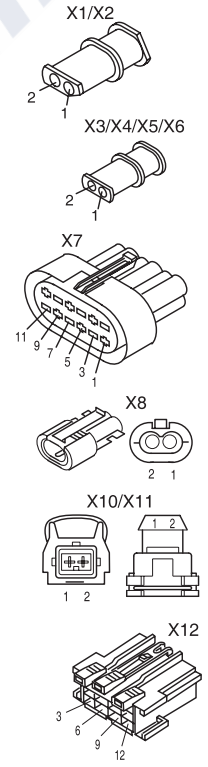
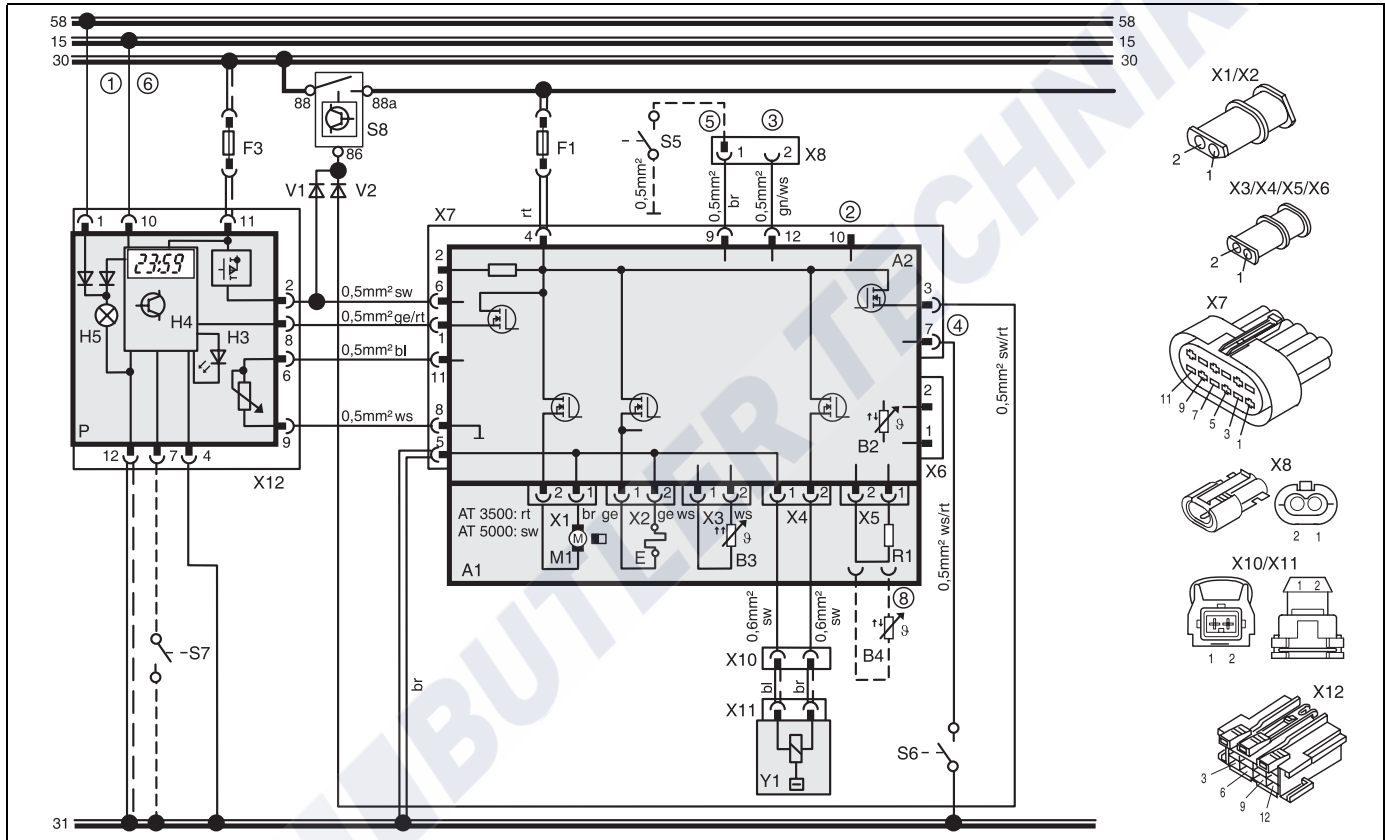

Fig. 33: System wiring diagram for the Air Top 3500 ST and Air Top 5000 ST, 12V/24V with combination timer and electrical battery isolation switch, for legend see pages 64 and 65

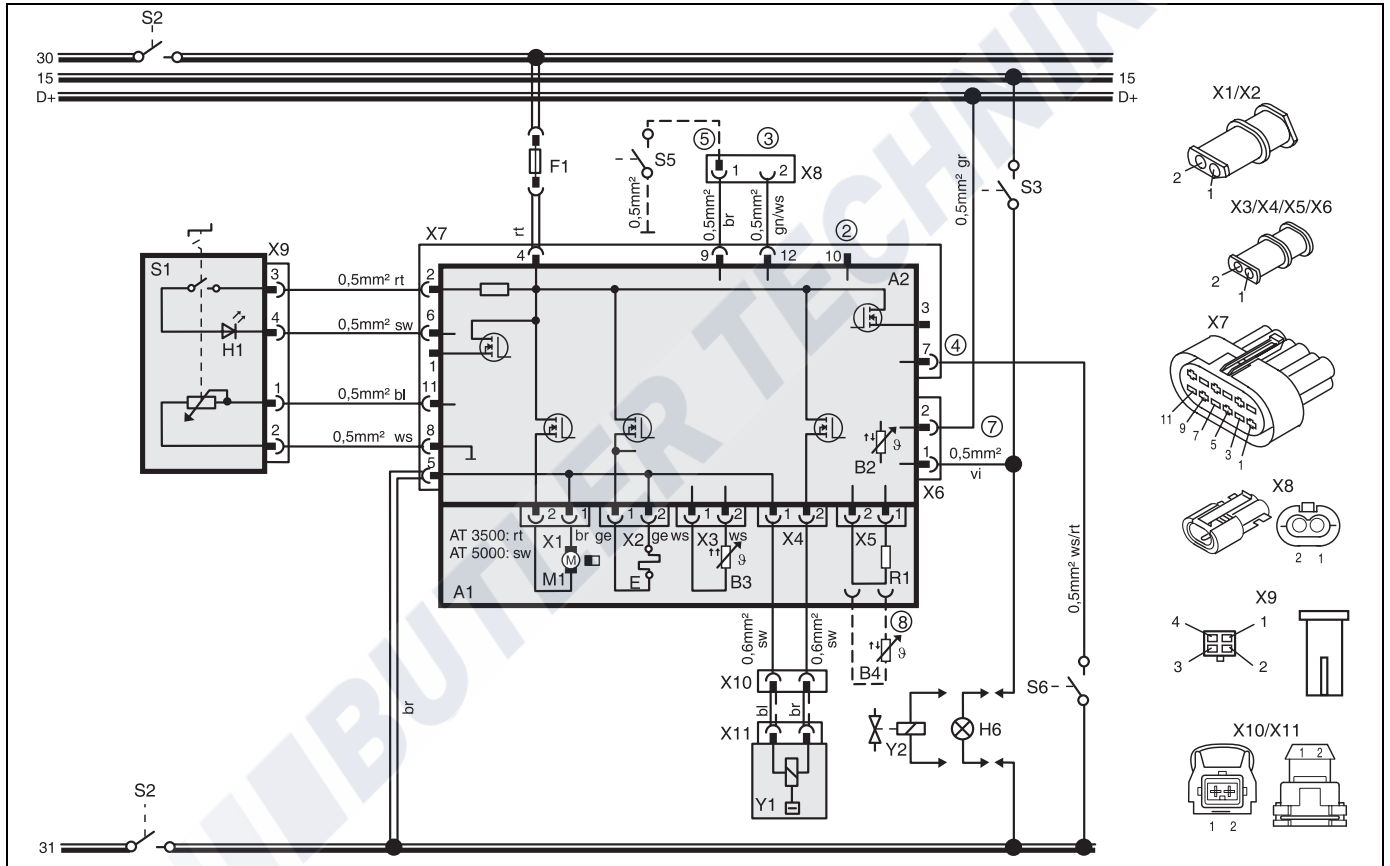







Fig. 34: System wiring diagram for the Air Top 3500 ST D and Air Top 5000 ST D, 24V ADR mode with control element, for legend see pages 64 and 65

## Legend for circuit diagrams

### 13 Legend for circuit diagrams

1. With positive from terminal (15/75) to connection 10:  
Permanent operation for immediate heat as long as the ignition is switched on  
Without positive at connection 10:  
Heating time is variably programmable (10 min to 120 min), default setting 120 min
2. Diagnostic K cable
3. W bus
4. Input pin (pin 7/plug X7, cable colour on wiring harness: white/red):  
"Ventilation" (fan speed depends on the position of the control element)  
Pin 7 with "Boost" assignment only on Air Top 5000 ST Boost heater
5. CO<sub>2</sub> adjustment (see workshop manual)
6. **NOTE:**  
If the connection is made to terminal 30, permanent heating is possible when the ignition is switched off!  
In this case no connection must be made to terminal 15/75.
7. **NOTE:**  
Grey and violet cables required for ADR function
8. External temperature sensor
9. Fuse installed in vehicle

Cable cross-sections		
	< 7.5 m	7,5 -15 m
	0.75 mm <sup>2</sup>	1.0 mm <sup>2</sup>
	1.0 mm <sup>2</sup>	1.5 mm <sup>2</sup>
	1.5 mm <sup>2</sup>	2.5 mm <sup>2</sup>
	2.5 mm <sup>2</sup>	4.0 mm <sup>2</sup>
	4.0 mm <sup>2</sup>	6.0 mm <sup>2</sup>

Cable colours	
bl	blue
br	brown
ge	yellow
gn	green
gr	grey
or	orange
rt	red
sw	black
vi	violet
ws	white

Item	Description	Comment
A1	Heater	Air Top 3500 ST/5000 ST
A2	Control module	
B2	Temperature sensor	In control unit
B3	Overheating sensor	Overheating guard
B4	Temperature sensor	External
E	Glow plug / Flame monitor	
F1	Fuse 24 V 15A/12V 20A	Flat fuse SAE J 1284
F2	Fuse 20 A	Flat fuse SAE J 1284
F3	Fuse max. 15A	Flat fuse SAE J 1284
H1	LED, green (in item S1)	Indicator
H3	LED red (in item P)	Light in immediate heat button, ready indicator, Switch-on indicator
H4	Heating symbol in the display (in item P)	Indicator
H5	Light (in item P)	Display and button lights
H6	Light (at least 1.2 W)	Switch-on indicator pumping device
K	Relay with free-wheeling diode	for vehicle fan
M1	Motor	Combustion and hot air fan
M3	Motor	Vehicle fan
P	Combination timer (1531)	Timer and setpoint generator
R1	Resistor 620 Ω	With internal temperature sensor only
S1	Control element	Setpoint generator switch
S2	1 or 2-pin disconnecting switch	Emergency Stop switch
S3	Switch	On and for pumping device
S5	Switch	CO <sub>2</sub> setting

Item	Description	Comment
S6	Switch	Ventilation or boost
S7	Momentary-contact switch	Immediate heat button remote control
S8	Battery isolation switch	
V1	Diode	
V12	Diode	
X1	Plug connector, 2-pin	To item A2 (ST B)
X2	Plug connector, 2-pin	To item A2 (ST V)
X3	Plug connector, 2-pin	To item A2 (ST U)
X4	Plug connector, 2-pin	To item A2 (ST Z)
X5	Plug connector, 2-pin	To item A2 (ST Y)
X6	Plug connector, 2-pin	To item A2 (ST X)
X7	12-pin plug connection	To item A2 (ST 1)
X8	Plug connector, 2-pin	
X9	Plug connector, 4-pin	to item S1
X10	Plug connector, 2-pin	
X11	Plug connector, 2-pin	to item Y1
X12	12-pin plug connection	to item P
Y1	Metering pump	
Y2	Solenoid valve	for pumping device



## **14 Starting the heater for the first time**

After you have installed the heater, bleed the fuel supply system carefully.

**NOTE:**

As a result of the low fuel consumption the heater must be switched on several times to fill the fuel line.

Conduct a trial of the heater to check all the connections for leaks and to ensure that they are secure. If the heater suffers a fault during operation, the fault must be located and remedied.

## 15 Fault lock-out

The control unit has identified errors on individual heater components and faults during the operation.

The heater is shut down (fault lock-out) if:

- No or incorrect start
- Temperature sensor defective
- Overheating sensor interrupt or short circuit
- Overheating sensor installed incorrectly
- Glow plug interrupt or short circuit
- Fan motor overload or blocked or short circuit or interrupt
- Error in the metering pump or overheating guard circuit (start phase only)
- Undervoltage less than 10 V or overvoltage greater than 15 V and for longer than 20 seconds (on 12 V heater)
- Undervoltage less than 20 V or overvoltage greater than 32 V and for longer than 20 seconds (on 24 V heater)
- Control unit defective
- Overheating

The fuel supply is stopped if the heater overheats.

The heater continues to run in the same way as if it is switched off manually.

After it stops the control unit will be set to fault lock-out.

The overheating is indicated by the indicator flashing 10 times. Rectify the cause of the fault. To reset the fault switch the heater on and off briefly (at least 2 seconds). If serious faults, such as overheating or no start, occur frequently, the heater will be set to permanent fault lock-out (F 12 or F 13) and cannot be restarted until it has been repaired by Webasto-trained personnel.

### 15.1. Error code output

#### NOTE:

The error code is output if the heater is fitted with a control element after an error has occurred by the switch-on indicator/error code indicator flashing. After 5 seconds of fast flashing, the error code will be output by a sequence of long flash pulses, the number of flashes is shown in the table below.

If the heater is fitted with a combination timer, an error message will appear on the display of the timer after a fault occurs:

- |      |   |
|------|---|
| F 00 | Control unit error / incorrect parameter set / warm start recognition                     |
| F 01 | No start (after 2 attempts to start) / no flame formation                                 |
| F 02 | Flame failure (repeated >3)   |
| F 03 | Undervoltage or overvoltage   |
| F 04 | Premature flame recognition   |
| F 06 | Temperature sensor interrupt or temperature sensor short-circuit                          |
| F 07 | Metering pump interrupt or metering pump short circuit                                    |
| F 08 | Fan motor interrupt or fan motor short circuit or fan motor overload or fan motor blocked |
| F 09 | Glow plug interrupt or glow plug short circuit  |
| F 10 | Overheating / permanent heater lock-out   |
| F 11 | Overheating sensor interrupt or overheating sensor short circuit                          |
| F 12 | Heater lock-out   |
| F 13 | Heater lock-out permanent   |
| F 14 | Overheating sensor incorrect position   |
| F 15 | Setpoint generator interrupt  |

## Technical data

### 16 Technical data

Except where limit values are specified, the technical data refer to the usual heater tolerances of  $\pm 10\%$  at an ambient temperature of  $+20\text{ }^\circ\text{C}$  and at the rated voltage and in rated conditions.

#### 16.1. Electrical components:

Control unit, motor, metering pump, lamp in the timer and glow plug / flame monitor are designed for either 12 V or 24 V.

The timer, overheating sensor and temperature sensor component are not dependent on voltage.

#### 16.2. Fuel for Air Top 3500 ST B (petrol)

##### Fuel for Air Top 5000 ST B (petrol)

The fuel specified by the manufacturer must be used.

#### 16.3. Fuel for Air Top 3500 ST D (diesel/EL heating oil)

##### Fuel for Air Top 5000 ST D (diesel/EL heating oil)

The diesel fuel specified by the manufacturer must be used. Class EL heating oil (not L heating oil) may also be used as long as it complies to the normal quality available on the German market pursuant to DIN 51603.

We know of no negative influences due to additives. If fuel is extracted from the vehicle's tank, follow the additive instructions issued by the vehicle manufacturer.

If you change to low-temperature fuel, the heater must be operated for approx. 15 minutes so that the fuel system is filled with the new fuel.

The Air Top 3500 ST and Air Top 5000 ST D heaters are also licensed for use with PME (bio-diesel), which complies with DIN EN 14214.

Heater	Operation	Air Top 3500 (5000) ST B	Air Top 3500 (5000) ST D Air Top 3500 ST D Volume Plus
Type test permit		e1*72/245*95/54*1221*00 e1*2001/56*0021*00 e1*2001/56*0020*00	
Model		Air heater with evaporator burner	
Heat output	Control range	1.8 – 3.5 kW	1.5 – 3.5 (5.0) kW
Fuel		Petrol	Diesel/PME
Fuel consumption	Control range	0.17 – 0.35 (0.52) kg/h (0.19 – 0.46 (0.66) l/h)	0.19 – 0.35 (0.50) kg/h (0.18 – 0.42 (0.60) l/h)
Rated voltage		12 V	12 V      24 V
Operating voltage range		10.5 - 16 V	10.5 - 16 V      21 -32 V
Rated power consumption	Control range	15 - 33 (95) W	
Max. ambient temperature:			
Heater:			
- Operation		-40... +40 °C	
- Storage		-40... +85 °C	
Metering pump - Operation		-40... +20 °C	
- Storage		-40... +85 °C	
Control element- Operation		-40... +75 °C	
- Storage		-40... +85 °C	
Maximum combustion air inlet temperature		-40... +20 °C	
Adjustment range for interior temperature		+5... +35 °C	
Delivery rate for hot air at fan speed	against 0.5 bar	max. 132 (200) m <sup>3</sup> /h at 3600 (5000) rpm	
CO <sub>2</sub> in exhaust gas (permitted function range)		<b>1.5 kW:</b> 5.0-8.0 % <b>3.5/5.0 kW:</b> 9.0-12.5 %	<b>1.5 kW:</b> 5.0-8.0 % <b>3.5/5.0 kW:</b> 9.0-12.5 %
Heater dimensions		Length 423 ± 2 mm Width 148 ± 1 mm Height 162 ± 1 mm	
Weight		5.9 kg	

**17 Version**

**Air Top 3500 ST B (petrol)**

**Air Top 5000 ST B (petrol)**

Air heater for petrol (12 V)

**Air Top 3500 ST D (diesel)**

**Air Top 5000 ST D (diesel)**

Air heater for diesel/EL heating oil (12 or 24 V)

**Air Top 3500 ST Volume Plus D (diesel)**

Air heater for diesel/EL heating oil (12 or 24 V)

18 Drilling template

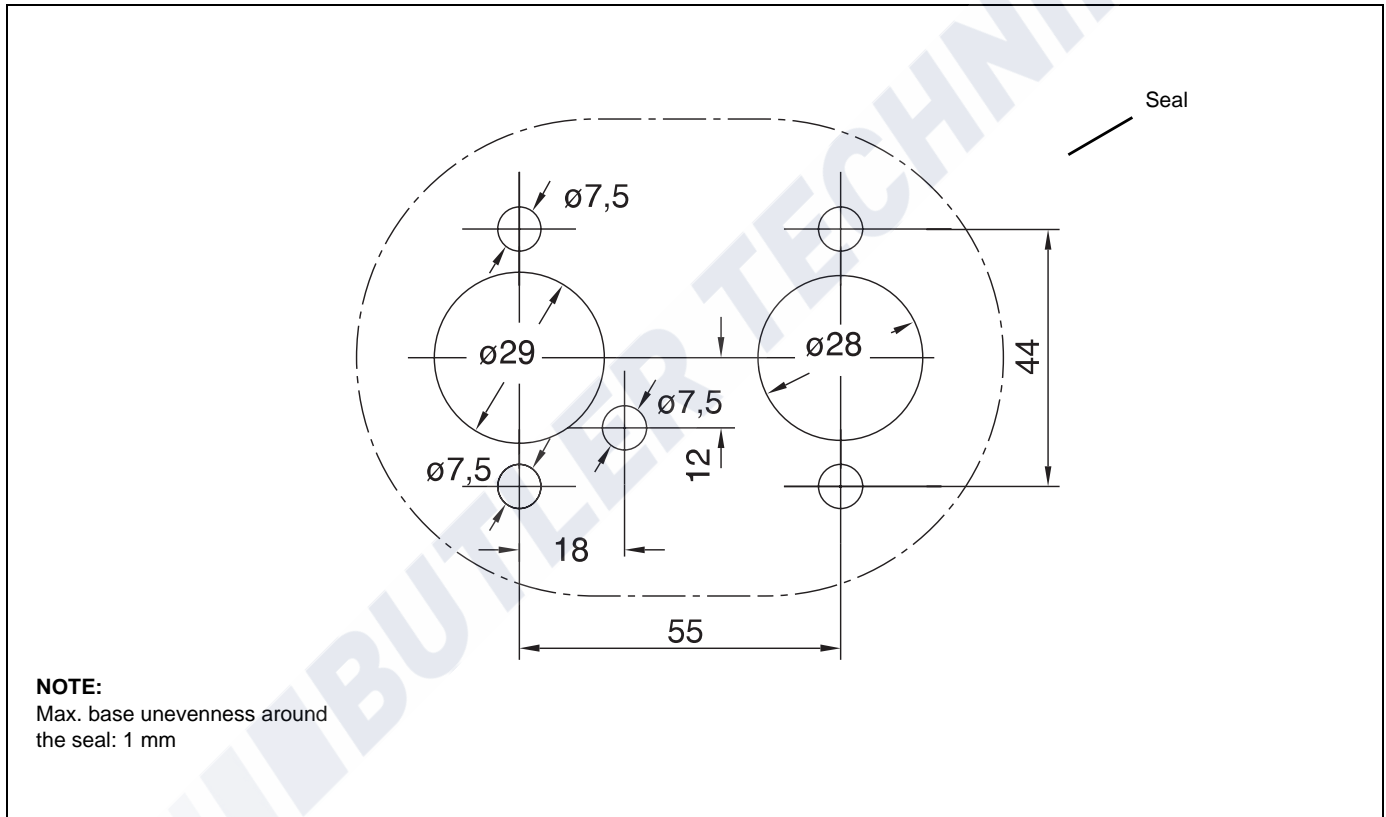

Fig. 35: Drilling template