

**Air Top 2000
Diagnosis**

Air Top 2000

Type AT 2000 B (Fuel)
Type AT 2000 D (Diesel)

List of Contents

1	Introduction	
1.1	Scope and Purpose	101
1.1.1	Use of Air Heaters	101
1.2	Meaning of Warnings, Cautions and Notes	101
1.3	Additional Documentation to be used	101
1.4	Safety Information and Regulations.....	101
1.4.1	Legal Provisions for Installation.....	101
1.4.2	General Safety Notes	103
1.5	Corrections and Improvements.....	103
2	General Description	
2.1	Combustion and Heating Air Fan.....	201
2.2	Heat Exchanger	202
2.3	Burner Insert with Combustion Tube	202
2.4	Control Unit / Control Circuit Board	202
2.5	Flame Sensor	203
2.6	Glow Plug	203
2.7	Temperature Limiter	203
2.8	Dosing Pump	203
3	Functional Description	
3.1	Functional Description Air Top 2000 without Diagnosis	301
3.1.1	Control Element.....	301
3.1.2	Switch-On	301
3.1.3	Stabilization	301
3.1.4	Heating Operation	301
3.1.5	Control Operation	302
3.1.6	Control Idle	302
3.1.7	Switch-Off	302
3.1.8	Functions of the Air Heater in ADR Vehicles.....	302
3.1.9	Switch-off upon Failure.....	302
3.2	Functional Description Air Top 2000 Diagnosis.....	304
3.2.1	Control Element.....	304
3.2.2	Switch-On	304
3.2.3	Stabilization	304
3.2.4	Heating Operation	305
3.2.5	Control Operation	305
3.2.6	Control Idle	305
3.2.7	Switch-Off	305
3.2.8	Functions of the Air Heater in ADR Vehicles.....	305
3.2.9	Switch-off upon Failure.....	306
4	Technical Data.....	401

5	Troubleshooting	
5.1	General	501
5.2	General Failure Symptoms	501
5.3	Failure Symptoms during Operation	502
5.4	Error Code Output (Air Top 2000 Diagnosis).....	503
6	Functional Tests	
6.1	General	601
6.2	Adjustments	601
6.2.1	Adjustment of the CO ₂ Contents	601
6.3	Components Testing.....	602
6.3.1	Glow Plug Resistance Test.....	602
6.3.2	Flame Sensor Resistance Test.....	602
7	Circuit Diagrams	
7.1	General	701
8	Servicing	
8.1	General	801
8.2	Work on the Air Heater	801
8.3	Work on the Vehicle.....	801
8.4	Air Heater Test Run	801
8.5	Servicing	801
8.6	Visual Inspections and Installation Regulations.....	801
8.6.1	Heating Air System	801
8.6.2	Fuel Supply.....	802
8.6.3	Dosing Pump	804
8.6.4	Fuel Filter.....	804
8.6.5	Combustion Air Supply	805
8.6.6	Exhaust Line	805
8.6.7	Combustion Air Intake and Exhaust Lines.....	805
8.6.8	Electrical Connections	806
8.7	Removal and Installation.....	808
8.7.1	Air Heater, Removal and Installation	808
8.7.2	Replacement of Control Unit.....	808
8.7.3	Replacement of Temperature Limiter	808
8.8	Installation of new Control Units	811
8.8.1	Replacement of Control Unit Air Top 2000 (12 Volt) with External Temperature Sensor.....	811
8.8.2	Replacement of Control Unit Air Top 2000 (24 Volt) not ADR.....	811
8.8.3	Replacement of Control Unit Air Top 2000 (24 Volt) ADR.....	812
8.9	First Operation	812

9 Repair

9.1 General 901

 9.1.1 Work on Components after Disassembly 901

 9.1.2 Incorporation of Modifications..... 901

9.2 Disassembly and Assembly 902

 9.2.1 Removal of Housing Components/Covers 902

 9.2.2 Replacement of Control Unit 903

 9.2.3 Replacement of Temperature Limiter 903

 9.2.4 Replacement of Combustion Air Fan..... 904

 9.2.5 Replacement of Flame Sensor 906

 9.2.6 Replacement of Glow Plug 906

 9.2.7 Replacement of Burner Insert, Combustion Tube, and Heat Exchanger 909

10 Packaging/Storage and Shipping

10.1 General 1001

List of Figures

301	Functional Diagram (Air Top 2000 without Diagnosis).....	303
501	General Failure Symptoms	501
502	Failure Symptoms during Operation	502
601	Adjustment of CO ₂ Contents.....	601
701	Terminal Pin Assignment, Air Top 2000 Diagnosis.....	701
702	Terminal Pin Assignment, Air Top 2000 without Diagnosis	702
703	Circuit Diagram Automatic Control Air Top 2000 Diagnosis, 12V/24V with Control Element.....	703
704	Circuit Diagram Automatic Control Air Top 2000 Diagnosis, 12V/24V with Combination Timer	704
705	Circuit Diagram Automatic Control Air Top 2000 Diagnosis, 12V/24V with Control Element and Standard Timer	705
706	Circuit Diagram Automatic Control Air Top 2000 Diagnosis, 24V ADR Operation with Control Element.....	706
707	Circuit Diagram Automatic Control Air Top 2000 Diagnosis, 24V ADR Operation with Combination Timer	707
708	Circuit Diagram Automatic Control Air Top 2000 Diagnosis, 24V ADR Operation with Combination Timer and 2 Auxiliary Drives	708
709	Circuit Diagram Automatic Control Air Top 2000 without Diagnosis, 12V with Control Element.....	709
710	Circuit Diagram Automatic Control Air Top 2000 without Diagnosis, 12V with Control Element and Timer.....	710
711	Circuit Diagram Automatic Control Air Top 2000 without Diagnosis, 24V with Control Element.....	711
712	Circuit Diagram Automatic Control Air Top 2000 without Diagnosis, 24V with Control Element and Timer.....	712
713	Circuit Diagram Automatic Control Air Top 2000 without Diagnosis, 24V with Control Element, ADR	713
714	Circuit Diagram Automatic Control Air Top 2000 Diagnosis, 24V ADR Operation with Control Element in Vehicles without Auxiliary Drive	714
715	Connection Diagram, Air Top 2000 Diagnosis with Combination Timer (not ADR!)	715
801	Fuel Supply	802
802	Webasto Fuel Tank Tap.....	803
803	Fuel Tapping from Plastic Tank (tapping via fuel drain plug).....	803
804	Fuel Tapping from Plastic Tank (tapping via fitting plate)	803
805	Pipe/Hose Connection	804
806	Dosing Pump, Installation Position and Attachment	804
807	Fuel Filter	804
808	Exhaust Muffler, Direction of Flow	805
809	Exhaust Pipe Outlet, Installation Position	805
810	Removal of Fuse Holder Attachment Plate.....	806
811	Fuse Holder, Installation Position	806
812	Control Element	806
813	Pulling the Plug.....	806
814	Example of an Installation	807
815	Replacement of Control Unit and Temperature Limiter (Air Top 2000 without Diagnosis)	809
816	Replacement of Control Unit and Temperature Limiter (Air Top 2000 Diagnosis).....	810
901	Removal of Housing Components/Covers.....	903
902	Replacement of Combustion Air Fan (Removal)	904
903	Replacement of Combustion Air Fan (Disassembly)	905
904	Disassembly of Heat Exchanger	907

1 Introduction

1.1 Scope and Purpose

This repair shop manual is intended to support familiarized personnel in the repair of air heaters Air Top 2000 of the fuel and Diesel type as well as of Air Top 2000 Diagnosis with serial no. 30.000 and up.

1.1.1 Use of Air Heaters

The air heaters Air Top 2000 and Air Top 2000 Diagnosis are used to

- heat the cabin
- defrost the windscreens.
-

They are not cleared for heating a transportation compartment for dangerous goods.

The heaters operate independent from the vehicle engine and are connected to the fuel tank and to the electrical system of the vehicle. Their use is possible in vehicles with water- or air-cooled engines.

1.2 Meaning of Warnings, Cautions and Notes

WARNINGS, CAUTIONS, and NOTES in this manual have the following meaning:

WARNING

This heading is used to highlight that non-compliance with instructions or procedures may cause injuries or lethal accidents to personnel.

CAUTION

This heading is used to highlight that non-compliance with instructions or procedures may cause damage to equipment.

NOTE

This heading is used to highlight and draw specific attention to information.

1.3 Additional Documentation to be used

This workshop manual contains all information and procedures necessary for the repair of heaters Air Top 2000 and Air Top 2000 Diagnosis.

The use of additional documentation is normally not necessary.

Operating instructions/installation instructions and the vehicle specific installation proposal may be used as complementary information as necessary.

1.4 Safety Information and Regulations

The general safety regulations for the prevention of accidents and the relevant operating safety instructions have to be observed at all times. "General Safety Regulations" beyond the scope of these regulations are detailed in the following. The specific safety regulations applicable to this manual are highlighted in the individual chapters by Warnings, Cautions, and Notes.

1.4.1 Legal Provisions for Installation

Within the scope of the StVZO (Road Licensing Regulations of the Federal Republic of Germany) "Design General Approvals", laid down by the Federal Office for Motor Traffic, exist for the Water Heater Air Top 2000 and Air Top 2000 Diagnosis with the following official marks of conformity:

- ~ S 270 (Diesel)
- ~ S 277 (Fuel)

The installation of the heaters is to be performed in accordance with the installation instructions and must be checked in case of

- a) the vehicle type inspection in accordance with § 20 StVZO
- b) the individual inspection in accordance with § 21 StVZO or
- c) the examination in accordance with § 19 StVZO performed by an officially authorised expert or examiner for road traffic, a vehicle inspector or a public servant as per section 4 of Annex VIII b to the StVZO.

In the event of c) the installation must be certified on the acceptance certificate included in the copy of the "General Operating License" or on a formsheet according to the specimen of an "approval" included in the Traffic rules 1994, Page 148 giving details about

- manufacturer
- type of vehicle, and
- vehicle identification number.

This validates the "Design General Approval". The acceptance certificate must be kept with the vehicle. The year of first operation must be permanently marked on the identification label by removing the numerals of the years not applicable.

The heat exchanger of the air heater remains serviceable for a maximum of 10 years and must then be replaced with an original spare part by the manufacturer or by one of its authorized workshops. The heater must then be provided with a label marked with the sales date and with the words "Original Spare".

When replacing the heat exchanger it is mandatory to also replace the overheat protection element (temperature limiter) to avoid possible malfunctions of old temperature limiters in use.

Should exhaust pipes be routed through rooms accommodating persons, these pipes shall also be renewed after 10 years by original spare parts. When removing the heater the gasket below must be renewed.

The heaters are cleared for heating the passenger and driver cabins but not for heating compartments intended for the transportation of dangerous goods. The use of the heater in special vehicles (e.g. vehicles for the transportation of dangerous goods ADR) or vehicles not subject to the StZVO (e.g. ships) are ruled by partially regional regulations. For the installation of the AT 2000 D in vehicles used for the transportation of dangerous goods, in addition to the StVZO, the requirements in ADR 002 and ADR 003 (Technical Guidelines for the Transportation of Dangerous Goods on Roads) must be met.

Heating Air System

Heating air intake openings must be arranged so that under normal operating conditions exhaust fumes of the vehicle engine or air heater are not likely to be expected.

Extracting combustion air from the vehicle interior is not permissible.

Combustion Air Line

The combustion air required must be taken from the exterior. Within rooms accommodating persons, the combustion air lines must not have more than four disconnects and a splash-water protected exterior wall feedthrough. The disconnects must be sealed in a way not to exceed a leak rate of 200 l/h at an overpressure of 0.5 mbar. The line including feedthrough, disconnects, material and specific type must be described in the installation instructions. The line must require tools for installation and removal, must be protected against damage, and must be shock-proof.

Exhaust Line

Heaters must be designed to discharge the exhaust to the exterior. Exhaust pipes must be routed so that exhaust fumes are unlikely to penetrate into the vehicle's interior. The function of any parts of the vehicle essential for its operation must not be impaired. Condensate or water penetrated must not be able to accumulate in the exhaust line. Drain holes are permissible; these must drain the fluid to the exterior via lines sealed against the vehicle interior. The exhaust line outlet is to be positioned to the top, to the side, or in case of exhaust venting below the vehicle floor, to the nearest possible location of the vehicle's or cockpit's side or rear end.

In compartments accommodating persons, exhaust lines must not have more than one disconnect and must have a splash-water protected feedthrough in the exterior wall/floor. For water, that has penetrated into the exhaust line, the connection of a drain line with a metal-sealing joint is permissible. The drain pipe must be routed sealed through the exterior wall or the vehicle floor.

The heat exchanger, the exhaust line connected, as well as the possible drain pipe must be sealed so that with an overpressure of double the overpressure of the exhaust having the maximum permissible exhaust line length – at least however at an overpressure of 0.5 bar – a total leak rate of 30 l/h is not exceeded.

The line including feedthrough, disconnects, material and specific type must be described in the installation instructions. The line must require tools for installation and removal, must be protected against damage, and must be shockproof.

Metal lines must be used. These may not heat to more than 110° C should there be the possibility of contact within the room interior. Protective devices against contact may be fitted.

Combustion Air Inlet and Exhaust Outlet

During installations these ports for combustion air entry and exhaust fume exit must be of such type, that a ball with a diameter of 16 mm cannot be inserted. Electrical lines, switch gear and control gear of the heater must be located in the vehicle so that their proper function cannot be impaired under normal operating conditions.

For the routing of fuel lines and the installation of additional fuel tanks §§ 45 and 46 of the StVZO are to be adhered to.

The most important regulations are: Fuel lines are to be designed in such a way that they remain unaffected by torsional stresses in the vehicle, engine movement and the like. They must be protected against mechanical damage.

Fuel-carrying parts are to be protected against excessive heat and are to be arranged so that any dripping or evaporating fuel can neither accumulate nor be ignited by hot components or electrical equipment.

In busses, fuel lines and fuel tanks may be located neither in the passenger area nor in the driver's compartment. In these type of vehicles the fuel tanks must be located such that they do not pose a direct hazard to the exits in the event of a fire. Fuel supply must not be by means of gravity or pressurization of the fuel tank.

1.4.2 General Safety Notes

The heater must not be installed in the passenger or driver compartments of busses. Should the heater nevertheless be installed in such a compartment, the installation box must be sealed tight against the vehicle interior. There must be sufficient ventilation of the installation box from the exterior in order not to exceed a maximum temperature of 40° C in the installation box. Excessive temperatures may cause malfunctions.

Installation Instructions for Webasto Fuel Tanks for Fuel Supply of Heaters in Vehicles

In busses the installation is not permitted in the passengers or driver's compartment.

The fuel filler neck must not be located in the passengers or driver's compartment of any type of vehicle. Fuel reservoirs for carburettor fuel must not be located immediately behind the vehicle front fairing. They must be away from the engine to prevent fuel fires in case of accidents.

The same applies to towing vehicles with open cockpit.

It is mandatory to install the seal between the heater mounting and the vehicle floor to prevent poisonous exhaust fumes from entering the vehicle interior.

All fuel line connections must be tight, must show no damage and have to be inspected in regular intervals (at least in the same frequency as vehicle inspections).

When detecting damages or leaks the heater must not be operated until repair will have been performed by an authorised Webasto repair shop.

NOTE

Make heater inoperative by removing fuse. The fuel lines (Mecanyl hoses) must not be in direct contact with the exhaust pipe and be provided with a heat insulation as required to prevent fires.

Keep air intakes and exit ports for warm and heating air clean and free from foreign objects. Contaminated and clogged air ducts may cause overheating and response of the temperature limiter. After an overheat condition with automatic switch-off check air ducting is free from contamination and remove all objects that might block the airstream or have damage repaired by an authorized Webasto repair shop. Then reset the temperature limiter. Should these corrective actions not cure the problem (overheating occurs again), consult an authorized Webasto repair shop. Never remove the air intake screen upstream of the heater.

The air jets with adjustable flops must always be open in a way that the airflow through the heater is not blocked. A frequently restricted or blocked airflow may cause long time damage. Should a heater be located in a stowage compartment, it must be ensured that no flammable material is stowed in this compartment and that other material does not restrict the air supply of the heater.

Air lines must be securely fastened to the heater and the air jets (e.g. with pipe clamps).

Do not step on the heater and do not deposit heavy objects on or throw against the heater.

Do not throw garments, fabrics or similar material on top of the heater or in front of the heating air intake or exit. The warm air flow of the heater must not be restricted or blocked by easily flammable substances or material like rags, cleaning wool, etc., to prevent fires and smoke.

Flammable or explosive material or gasses must be kept away from the vicinity of the heater, the warm air ducting or the heating airflow.

The heater must not be cleaned with water, fluids or high pressure cleaners, etc.

Do not switch off heater with the battery master switch or the battery emergency off switch to prevent possible long time damage and malfunctions of the heater.

The operating condition of the heater – least on or off – must be clearly visible.

Non-compliance with the installation instructions and its procedures will void the warranty by Webasto. The same applies for repairs performed by unskilled personnel or not using original spare parts. This will also invalidate the official marks of conformity and thus the vehicle's permit of operation.

Make sure to read the operating instructions before you operate the heater.

1.5 Corrections and Improvements

Deficiencies, improvements, or proposals for correction of this workshop manual are to be mailed to:

Webasto Thermosysteme GmbH
Abt. Technische Dokumentation
D-82131 Stockdorf

Telefon: 0 89 / 8 57 94 - 5 42

Telefax: 0 89 / 8 57 94 - 7 57

BUTLER TECHNIK

2 General Description

The air heater Air Top 2000 and Air Top 2000 Diagnosis with serial no. 30.000 and up operating to the evaporator principle basically consists of:

- combustion and heating air fan
- heat exchanger
- burner insert with combustion tube
- control unit

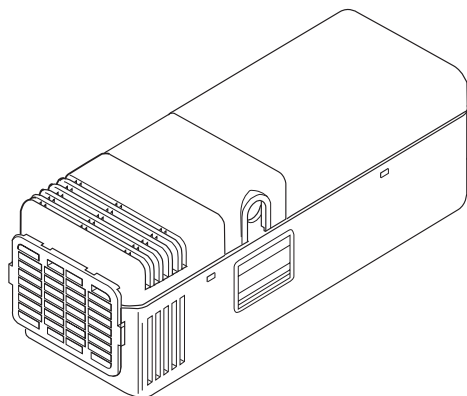

Air Heater Air Top 2000

For control and monitoring a

- control unit/control circuit board
- flame sensor
- glow plug
- temperature limiter
- temperature sensor

are located within the unit.

12 Volt heaters (Air Top 2000 without Diagnosis) may be controlled by means of an external temperature sensor. All heaters of air Top 2000 Diagnosis may be controlled by means of an external temperature sensor.

Fuel supply is provided externally by a fuel dosing pump.

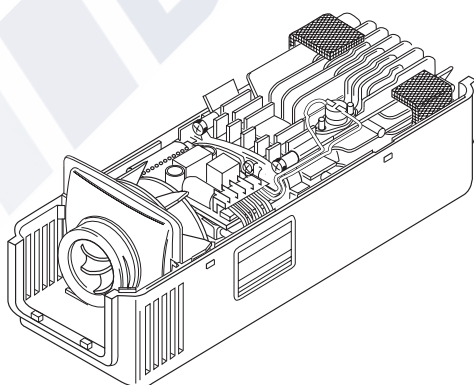

Air Heater Air Top 2000 without Diagnosis
(covers removed)

A malfunction in air heaters Air Top 2000 Diagnosis outputs an error code to the display of the combination or standard timer. When equipped with a control element the operating indicator flashes. In addition a heater checkout may be performed using a personal computer (refer to operating instructions PC air heater diagnosis).

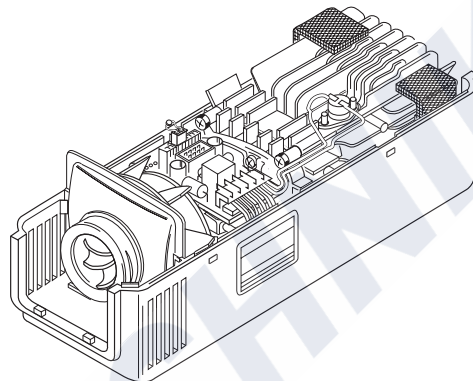

Air Heater Air Top 2000 Diagnosis
(covers removed)

2.1 Combustion and Heating Air Fan

The combustion and heating air fan delivers the air required for combustion from the combustion air inlet to the burner insert. By means of the fan the heating air is also delivered to the air outlet.

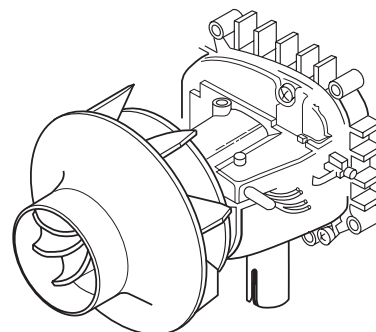

Combustion and Heating Air Fan

2 General Description

Air Top 2000

2.2 Heat Exchanger

The heat exchanger dissipates the heat provided by combustion to the air delivered by the combustion and heating air fan.

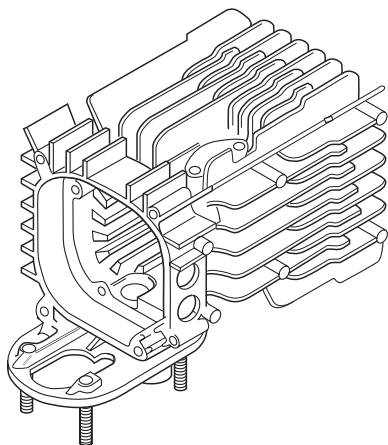

Heat Exchanger

2.3 Burner Insert with Combustion Tube

Within the burner insert fuel is distributed in the combustion tube across the burner cross-section. In the combustion tube the combustion of the fuel/air mixture takes place heating up the heat exchanger.

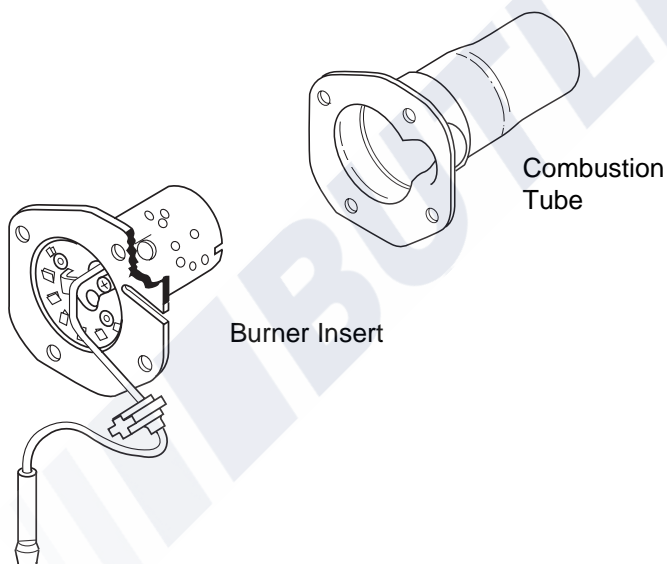

2.4 Control Unit / Control Circuit Board

Air Top 2000 without Diagnosis

The control unit/control circuit board is the central controlling unit for functional sequencing and monitoring of the combustion operation. A temperature sensor located on the side is used for temperature control. 12 Volt heaters may have the temperature sensor replaced against an external temperature sensor. The combustion and heating air fan may be set by means of a potentiometer.

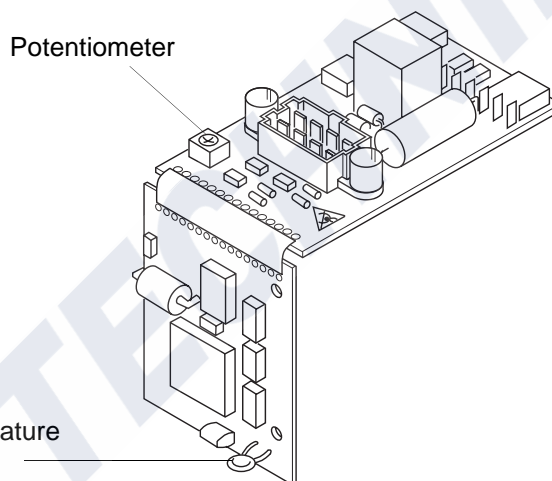

Control Unit Air Top 2000 without Diagnosis

Air Top 2000 Diagnosis

The control unit/control circuit board is the central controlling unit for functional sequencing and monitoring of the combustion operation. A temperature sensor located on the control unit is used for temperature control. All heaters may have the temperature sensor replaced against an external temperature sensor. The combustion and heating air fan may be set by means of a potentiometer.

A malfunction in air heaters Air Top 2000 Diagnosis outputs an error code to the display of the combination or standard timer. When equipped with a control element the operating indicator flashes. In addition a heater checkout may be performed using a personal computer (refer to operating instructions PC air heater diagnosis).

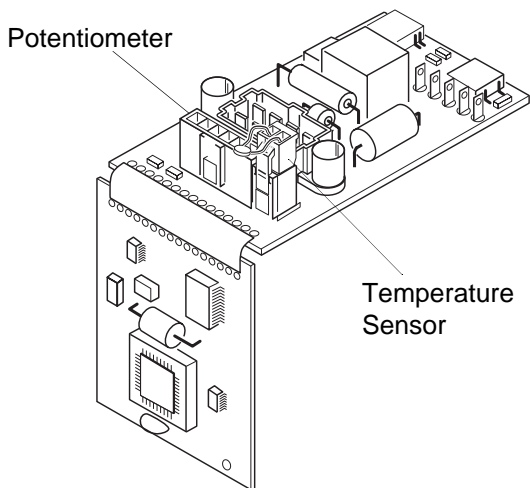

Control Unit Air Top 2000 Diagnosis

2.5 Flame Sensor

The flame sensor is a low-Ohm PTC resistor changing its resistance dependent on its heating by the flame. The signals are routed to the control unit for processing. The flame sensor monitors the flame operating condition over the complete duration of heater operation.

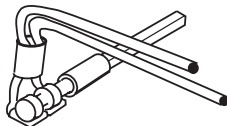

Flame Sensor

2.6 Glow Plug

The glow plug ignites the fuel/air mixture at the start of the air heater operation. The glow plug is acting as an electrical resistor and is located in the burner insert opposed to the flame side.

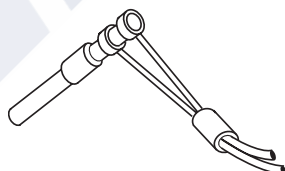

Glow Plug

2.7 Temperature Limiter

The temperature limiter protects the air heater against excessive operating temperatures. Overheat protection is activated at temperature higher than 150° C to interrupt the electrical circuit of the dosing pump and switch off the heater with run-down operation. After cooling down the electrical circuit is restored. The air heater may be switched on again (see 3.9).

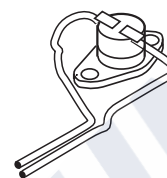

Temperature Limiter

2.8 Dosing Pump

The dosing pump is a combined supply, dosing and shut-off system for the fuel supply of the heater out of the vehicle's fuel tank.

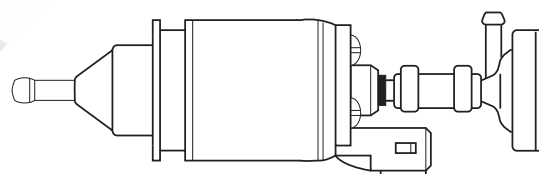

Dosing Pump DP 2 for Fuel and Diesel operated Heaters

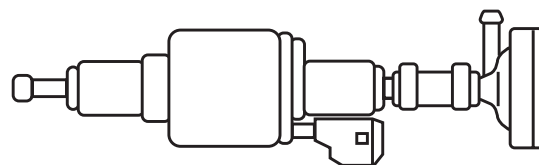

Dosing Pump DP 30 for Diesel operated Heaters

3 Functional Description

3.1 Functional Description Air Top 2000 without Diagnosis (Fig. 301)

3.1.1 Control Element

The control element is used to switch the air heater on and off, set the desired room temperature (air intake temperature between 10° C and 45° C), and to unlock a failure interrupt condition.

The green LED indication is used to indicate the operating condition (LED permanently on) and an over-heat condition (LED flashes).

NOTE

After application of power upon switch-on of the battery switch and selecting the control element "ON", the control unit enters the "error lockout" condition. Prior to a re-activation the control element has to be placed to "OFF".

3.1.2 Switch-On

The control element is set to the desired room temperature. When switching the air heater on, the operating indicator is illuminated and the glow plug is activated (cycled). The motor of the combustion and heating air fan starts high-speed operation for 1 second (break-away moment) and is then under slow-down control.

NOTE

Should the temperature of the intake air be above the selected, rated temperature, only the motor of the combustion and heating air fan will operate (control idle). Start operation will be initiated with a heating air temperature below the rated temperature.

After approx. 20 seconds (for fuel operated heaters after approx. 15 seconds) the fuel dosing pump is activated. After another 25 seconds the speed of the combustion and heating air fan is continuously increased to a higher rate and combustion begins. As soon as a flame is detected, combustion will be stabilized (see 3.1.3).

Should no normal combustion be achieved within 120 seconds (for fuel operated heaters after approx. 115 seconds), the speed of the combustion and heating air fan is increased for approx. 30 sec and there will be an automatic repeat start with the glow plug activated and fuel dosing pump deactivated (no fuel supply).

Should the no-combustion-condition persist, after another 80 seconds (for fuel operated heaters after approx. 85 seconds) there will be a switch-off by error lockout (see 3.1.9) with a run-down of the combustion and heating air fan lasting 120 seconds at 2/3 of its max. speed.

3.1.3 Stabilization

Diesel Operated Heaters

With the glow plug activated the operating speed of the combustion and heating air fan is increased. After another 20 seconds the speed of the combustion and heating air fan is continuously increased within 17 seconds to full load for full heat.

A flame-out during the speed rise control period causes a repeat start.

Fuel Operated Heaters

With the glow plug activated the operating speed of the combustion and heating air fan is continuously increased within 4 seconds to full load for full heat. A flame-out during the speed rise control period causes a repeat start.

3.1.4 Heating Operation

During operation the combustion exhaust gasses flow through the heat exchanger charging its walls with combustion heat, which in turn is taken up by the heating air delivered by the heating air fan to be routed to the vehicle interior.

The temperature of the heating air sucked in is measured by means of a temperature sensor fitted to the air intake side of the air heater or in case of 12 Volt heaters also by means of an externally located temperature sensor. A temperature below the one set with the control element increases the heater performance up to maximum heat. In order to extend the burner idle period of Diesel operated heaters during permanent operation with a heating performance in excess of 1.2 kW, the fuel dosing pump delivery rate is reduced every 30 minutes for 20 seconds.

A heating performance less than 1.2 kW causes the fuel delivery to the dosing pump to be interrupted every 30 minutes for 4 seconds. For both types of heaters (fuel and Diesel) heating operation is shortly interrupted every 9 hours like in control idle.

After reaching the temperature set with the control element, heating performance is controlled to decrease. The speed of the combustion and heating air fan slows down and the fuel delivery rate to the pump is reduced. When exceeding the air intake temperature set with the control element during minimum heating performance, the dosing pump is deactivated after 5 seconds and combustion terminates.

NOTE

The control unit/air heater reacts to new settings of the control element with a time delay.

3 Functional Description

Air Top 2000

3.1.5 Control Operation

During control operation fan speed and dosing pump rate of delivery are subject to heating performance. The glow plug is deactivated.

3.1.6 Control Idle

In case the air intake temperature set with the control element is exceeded and the minimum heating performance had been achieved for longer than 5 seconds, the fuel supply is cut off to terminate combustion. The motor of the combustion and heating air fan continues operation for another 155 seconds at 2/3 of maximum speed to cool down the air heater (run-down). In control idle the combustion and heating air fan runs at minimum speed. The operation indication remains lit. After reaching the air intake temperature set with the control element a new start procedure is launched (without break-away).

3.1.7 Switch-Off

Switching the heater off extinguishes the operation indication of the control element.

If no fuel has been delivered (within 20 seconds for Diesel operated heaters or within 15 seconds for fuel operated heaters after switch-on) or if the air heater is in control idle, the air heater is deactivated immediately without run-down.

If fuel supply has commenced it will be immediately stopped at switch-off. The fan speed decreases within 35 seconds to 2/3 of maximum. Subsequently or if the flame sensor detects "no flame" the fan speed is increased to maximum for 60 seconds and run-down is initiated to last 120 seconds. Run-down is automatically halted.

NOTE

Re-activation of the heater during run-down is permitted. Run-down will be completed first with a subsequent re-start.

3.1.8 Functions of the Air Heater in ADR Vehicles

NOTE

Applicable only for Air Top 2000 D Air Heaters installed in vehicles for the transportation of dangerous goods (ADR).

If the heater is deactivated using the control element, run-down will not change.

A short run-down (max. 40 seconds) is automatically activated if:

- the vehicle engine is turned off
- a conveyor facility is put into operation.

The short run-down time depends on the operational condition at which ADR switch-off occurs.

A 40 second run-down with maximum speed is initiated (ADR switch-off) when:

- air heater is still in the start phase; stabilization not yet achieved
- air heater is in normal run-down
- air heater is in control idle.

A 20 second run-down is switched on in normal combustion operation with the fuel delivery immediately halted maintaining the fan speed for 5 seconds. Then the speed is increased for 30 seconds within another 5 seconds.

For all heaters after July 1995 the short run-down out of all operating conditions is a max. of 20 seconds.

After an ADR switch-off the control unit is in the "error lockout" condition.

Prior to resuming operation the control element has to be set to "OFF".

3.1.9 Switch-off upon Failure

The control unit recognises failures of individual air heater components and malfunctions in the start sequence and in normal operation.

The air heater is deactivated and enters the error lockout mode under the following conditions:

- flame sensor resistance out of tolerance
- temperature sensor resistance out of tolerance
- glow plug/glow plug trigger defective
- fan speed too low, short circuit or open circuit
- error in dosing pump electrical circuit or of overheat protection (in start phase only)
- low voltage below 10 Volt and in excess of 20 seconds for 12 Volt heaters
- low voltage below 20 Volt and in excess of 20 seconds for 24 Volt heaters
- control unit defective

In case of overheating there will be no fuel supply.

A run-down like after manual switch-off will be performed.

After run-down the control unit is in the error lockout mode. Overheating is indicated by the operation indication flashing. For error unlock the air heater has to be switched off momentarily to be switched on again.

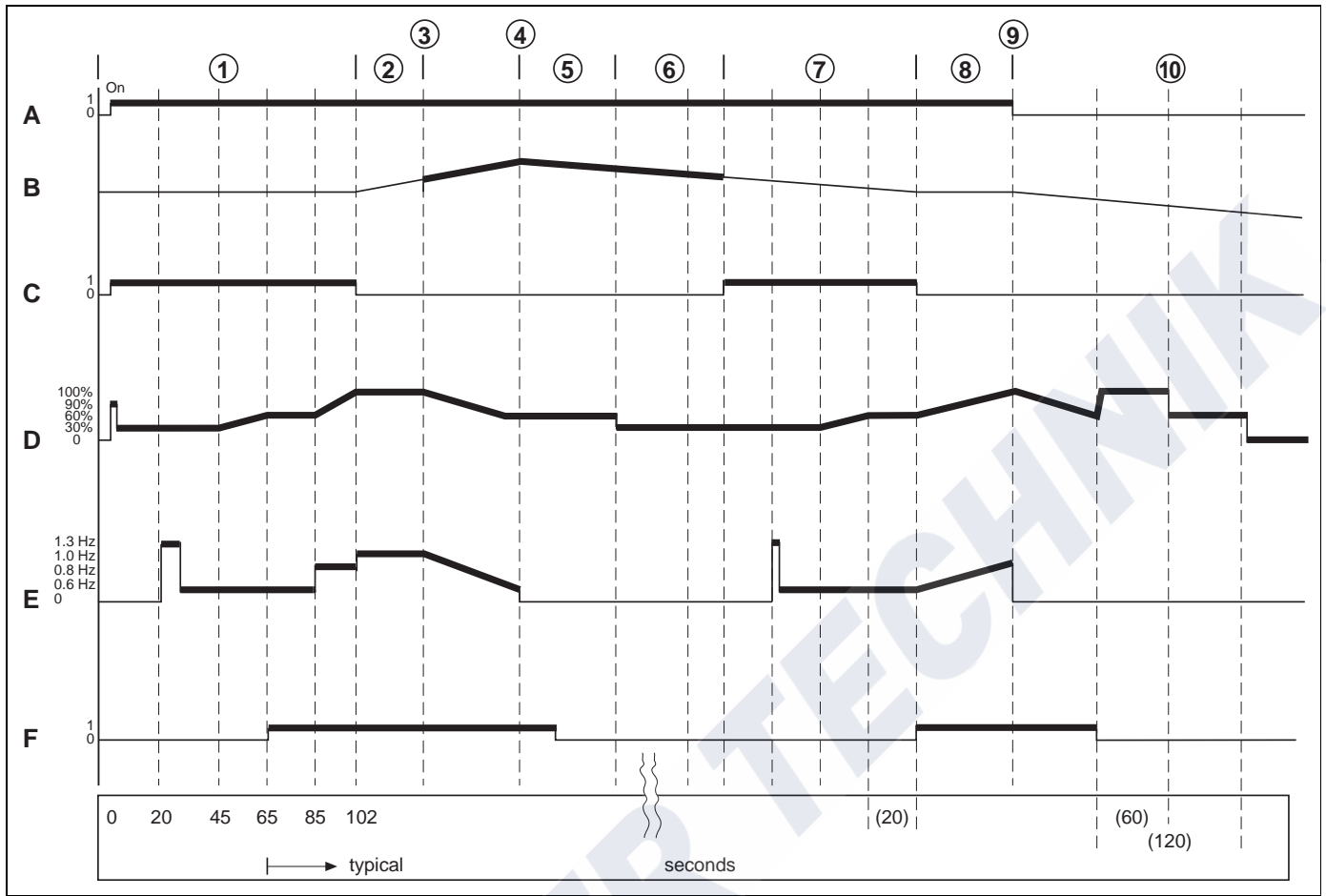

Fig. 301 Functional Diagram (Air Top 2000 without Diagnosis)

- | | |
|--|------------------------------------|
| ① Start | A = Control Element |
| ② Control Operation | B = Temperature Sensor |
| ③ Rated Value reached | C = Glow Plug |
| ④ Rated Value exceeded
(e.g. due to reduced heat consumption) | D = Combustion and Heating Air Fan |
| ⑤ Run-down | E = Dosing Pump |
| ⑥ Control Idle | F = Flame Sensor |
| ⑦ Start | |
| ⑧ Control Operation (increased heat consumption) | |
| ⑨ Switch-off | |
| ⑩ Run-down | |

3 Functional Description

Air Top 2000

3.2 Functional Description Air Top 2000 Diagnosis

3.2.1 Control Element

The control element is used to switch the air heater on and off, set the desired room temperature (air intake temperature between 10° C and 45° C), and to unlock a failure interrupt condition.

The green LED indication is used to indicate the operating condition (LED permanently on) and an over-heat condition (LED flashes).

NOTE

ADR Operation:

After application of power upon switch-on of the battery switch and selecting the control element "ON", the control unit enters the "error lockout" condition. Prior to a re-activation the control element has to be placed to "OFF".

3.2.2 Switch-On

The control element is set to the desired room temperature. When switching the air heater on, the operating indicator is illuminated and the glow plug is activated (cycled). The motor of the combustion and heating air fan starts high-speed operation for 1 second (break-away moment) and is then under slow-down control to approx. 30% (Diesel) or 50% (fuel) of full speed.

NOTE

Should the temperature of the intake air be above the selected, rated temperature, only the motor of the combustion and heating air fan will operate (control idle). Start operation will be initiated with a heating air temperature below the rated temperature.

The flame sensor function is checked. If the flame sensor at this time already signals "flame", there will be a 120 second run-down and an error lockout of the control unit. A malfunction of any other component monitored causes an error lockout without run-down.

After approx. 20 seconds (for fuel operated heaters after approx. 15 seconds) the fuel dosing pump is activated. After another 25 seconds the speed of the combustion and heating air fan is continuously increased to a higher rate and combustion begins. As soon as a flame is detected, combustion will be stabilized (see 3.2.3).

Should no normal combustion be achieved within 120 seconds (for fuel operated heaters after approx. 115 seconds), the speed of the combustion and heating air fan is increased for approx. 30 sec and there will be an automatic repeat start with the glow plug activated and fuel dosing pump deactivated (no fuel supply).

Should no proper combustion develop within 120 seconds (for fuel-operated within 115 seconds) the combustion and heating air fan speed is increased to full load for approx. 30 seconds (15 seconds for fuel-operated heaters) with the glow plug on and the dosing pump off (no fuel delivery) with a subsequent automatic restart.

Should the no-combustion-condition persist, after another 80 seconds (for fuel operated heaters after approx. 85 seconds) there will be a switch-off by error lockout (see 3.2.9) with a run-down of the combustion and heating air fan lasting 120 seconds at 2/3 of its max. speed.

2. Start (automatic restart)

Fan speed is again reduced to approx. 30% (for fuel operated heaters to approx. 50%) and fuel is delivered. During the next 20 seconds fan speed is increased to approx. 60% (for fuel-operated heaters to approx. 75%) of full speed. As soon as a flame is detected within the next 55 seconds, combustion will be stabilized.

Should there be no flame condition after a total fuel delivery period of 180 seconds, fuel delivery will be stopped and the glow plug deactivated. The combustion air fan continues full load operation for another 120 seconds (run-down) and the heater enters the error lockout condition.

3.2.3 Stabilization

Diesel Operated Heaters

With the glow plug activated the operating speed of the combustion and heating air fan is increased. After another 20 seconds the speed of the combustion and heating air fan is continuously increased within 17 seconds to full load for full heat.

NOTE

This operating condition is omitted if the set temperature (control idle) has already been achieved once.

The glow plug is deactivated and heating operation commences. A flame-out during speed up control causes a restart, 5 restarts an error lockout of the heater.

Fuel Operated Heaters

With the glow plug activated the operating speed of the combustion and heating air fan is continuously increased within 4 seconds to full load for full heat.

NOTE

This operating condition will be omitted if the start occurs after a control idle period.

The glow plug is deactivated and heating operation commences. A flame-out during speed up control causes a restart, 5 restarts an error lockout of the heater.

3.2.4 Heating Operation

During operation the combustion exhaust gasses flow through the heat exchanger charging its walls with combustion heat, which in turn is taken up by the heating air delivered by the heating air fan to be routed to the vehicle interior.

The temperature of the heating air sucked in is measured by means of a temperature sensor fitted to the air intake side of the air heater or by means of an externally located temperature sensor. A temperature below the one set with the control element increases the heater performance up to maximum heat. In order to extend the burner idle period of Diesel operated heaters during permanent operation with a heating performance in excess of 1.1 kW, the fuel dosing pump delivery rate is reduced every 15 minutes for 20 seconds.

A heating performance less than 1.1 kW causes the fuel delivery to the dosing pump to be interrupted every 30 minutes for 4 seconds. Additionally heating operation is briefly suspended every 9 hours like in control idle. For Diesel-operated heaters this is only applicable, if at this time heating performance is less than 1.1 kW.

3.2.5 Control Operation

During control operation fan speed and dosing pump rate of delivery are subject to heating performance. The glow plug is deactivated.

3.2.6 Control Idle

After reaching the temperature set with the control element, heating performance is controlled to decrease. The speed of the combustion and heating air fan slows down and the fuel delivery rate to the dosing pump is reduced. When exceeding the air intake temperature set with the control element during minimum heating performance, the dosing pump is deactivated after 5 seconds and combustion terminates.

Fan speed remains constant for 35 seconds and is then increased to approx. 60% of full speed for cooling the heater down. the fan then continues to operate at approx. 30% of full speed until temperature is below the temperature set with the control element. If temperature falls below the one set with the control element, the heater will restart (without break away).

NOTE

New settings on the control element are executed by the control unit/heater with a time delay.

3.2.7 Switch-Off

Switching the heater off extinguishes the operation indication of the control element.

If no fuel has been delivered or if the air heater is in control idle, the air heater is deactivated immediately without run-down.

If fuel supply has commenced it will be immediately stopped at switch-off. Fan speed remains constant and then decreases within 30 seconds to approx. 60% of full speed.

After this or with the flame sensor detecting "no flame", fan speed rises to maximum speed for 60 seconds and run down for 120 seconds is initiated. Run-down is at approx. 60% of full speed and is deactivated automatically.

NOTE

Re-activation of the heater during run-down is permitted. Run-down will be completed first with a subsequent re-start.

3.2.8 Functions of the Air Heater in ADR Vehicles

NOTE

Applicable only for Air Top 2000 D Air Heaters installed in vehicles for the transportation of dangerous goods (ADR).

If the heater is deactivated using the control element, run-down will not change.

A short run-down (max. 20 seconds) is automatically activated if:

- the vehicle engine is turned off
- a conveyor facility is put into operation

The short run-down time depends on the operational condition at which ADR switch-off occurs.

A 15 second run-down with maximum speed is initiated (TRS switch-off) when:

- air heater is still in the start phase; stabilization not yet achieved
- air heater is in normal run-down
- air heater is in control idle.

A 20 second run-down is switched on in normal combustion operation and in stabilization with the fuel delivery immediately halted maintaining the fan speed for 5 seconds. Then the speed is increased to maximum for 15 seconds within for a run-down.

After an ADR switch-off the control unit is in the "error lockout" condition. Prior to resuming operation the control element has to be set to "OFF".

3.2.9 Switch-off upon Failure

The control unit recognises failures of individual air heater components and malfunctions in the start sequence and in normal operation. The air heater is deactivated and enters the error lockout mode under the following conditions:

- flame sensor open or short circuit
- temperature sensor open or short circuit
- glow plug open or short circuit
- fan motor open or short circuit or fan speed wrong
- dosing pump open or short circuit
- overheating
- low voltage below 10 Volt or high voltage above 15 Volt in excess of 20 seconds for 12 Volt heaters
- low voltage below 20 Volt or high voltage above 30 Volt in excess of 20 seconds for 24 Volt heaters

A switch-off like in "switch-off" will be performed. In case of overheating there will be no fuel supply. After run-down the control unit is in the error lockout mode. The operation indication outputs a flash code. For error unlock the air heater has to be switched off momentarily (at least 2 seconds) to be switched on again.

4 Technical Data

As long as no threshold values are given, the following technical data are understood to include tolerances of ±10% usual for heaters at an ambient temperature of +20° C and at nominal voltage and conditions.

Electrical Components:

Control unit, combustion air fan, dosing pump, timer*, glow plug and control element are for 12 or 24 Volts operation.

The components temperature limiter and flame detector are independent of voltage.

* not for ADR

Propellant for Air Top 2000 B (Fuel):

The proper fuel is the fuel specified by the vehicle manufacturer.

Propellant for Air Top 2000 D (Diesel/Fuel Oil EL):

The proper Diesel fuel is the one specified by the vehicle manufacturer. Also fuel oil of class EL – not heating oil L – can be used as long as it meets the standard German quality specified in DIN 51603.

A persistent influence by additives is not known.

When tapping fuel from the vehicle fuel tank observe the manufacturer's fuel additive specifications.

When switching to low temperature propellants the heater must be operated for at least 15 minutes to prime the fuel system with the new type of fuel.

Air Heater	Operation	AT 2000 B	AT 2000 D	
Mark of conformity		~ S 277	~ S 270	
Heater type		Air heater with evaporator burner		
Heat flow	Control range	1.1 – 2.0 kW	0.9 – 2.0 kW	
Type of fuel		Fuel	Diesel/Fuel oil (EL)	
Fuel consumption	Control range	0.1 ... 0.2 kg/h (0.16 ... 0.27 l/h)	0.1 ... 0.21 kg/h (0.12 ... 0.24 l/h)	
Nominal voltage		12 Volt	12 Volt	24 Volt
Operation voltage		10 ... 15 Volt	10 ... 15 Volt	20 ... 30 Volt
Rated power consumption	Control range	9 ... 22 W		
Permitted ambient temp.: Heater – operation – storage Dosing pump – operation – storage Control element – operation – storage		–40° ... +40° C –40° ... +85° C –40° ... +20° C –40° ... +85° C –40° ... +75° C –40° ... +85° C		
Permitted combustion air intake temperature		–40° ... +20° C		
Setting range for indoor temperature	Control range	+10° ... +45° C		
Volume flow of heating air against 0.5 mbar	Max.	70 m ³ /h		
CO ₂ in exhaust (perm. functional range)	Max.	9.5 ... 10.5	9.5 ... 12.0	
Dimensions air heater		Length 322 ± 2 mm Width 130 ± 1 mm Heigh 122 ± 1 mm		
Weight, heater		2.6 kg		

BUTLER TECHNIK

5 Troubleshooting

5.1 General

This section describes troubleshooting procedures for the Air Heater Air Top 2000 and Air Top 2000 Diagnosis.

A malfunction in air heaters Air Top 2000 Diagnosis outputs an error code to the display of the combination or standard timer. When equipped with a control element the operating indicator flashes. In addition a heater checkout may be performed using a personal computer (refer to operating instructions PC air heater diagnosis).

CAUTION

Troubleshooting requires profound knowledge about structure and theory of operation of heater components and may only be performed by skilled personnel.

In cases of doubt refer to Sections 2 or 3 for functional interrelations.

NOTE

Only for ADR operation

After an ADR switch-off or power application by vehicle main power switch operation and the control element to "ON", the control unit will be in "error lockout". Prior to reactivation the control element must be set to "OFF" or the instant heat switch on the combination or standard timer be operated.

CAUTION

Troubleshooting is normally limited to the isolation of defective components.

The following causes for trouble are not considered and should always be checked for to exclude them as cause for trouble:

- **corrosion on connector**
- **loose contact on connector**
- **wrong crimping on connector**
- **corrosion on electrical wiring and fuses**
- **corrosion on battery terminals**

If individual components are checked, the control unit electrical connections must be disconnected.

After any correction of a failure a functional test has to be performed in the vehicle.

5.2 General Failure Symptoms

The following table (Fig. 501) lists the possible failure symptoms.

Failure Symptom	Probable Cause	Remedy
Air heater switches off automatically	No combustion after start or repeat start Flame extinguishes during operation Heater overheats Operation indication flashes Vehicle electrical system voltage too low	Switch off heater momentarily and switch on <u>once</u> again Switch off heater momentarily and switch on <u>once</u> again Check heat air ducting for obstructions, allow heater to cool down, switch off heater momentarily and switch on <u>once</u> again Charge battery Switch off heater momentarily and switch on <u>once</u> again
Heater expels black fumes	Combustion air and/or exhaust ducting blocked	Check combustion and exhaust ducting for obstructions

Fig. 501 General Failure Symptoms

5.3 Failure Symptoms during Operation

The following table (Fig. 502) lists the possible failure symptoms as they might occur during the functional sequence of operation.

In case of malfunction the failure is to be isolated and removed using this table. It is important to accurately identify the failure symptom.

Should the failure symptom not be contained in this table or the trouble not be detected under the specific failure

symptom listed, in emergencies assistance by our service technicians may be requested (Tel. 0 18 05 / 93 22 78).

NOTE

Overheating and dosing pump failure are always indicated additionally after run-down by the flashing LED of the control element.

In all cases of trouble also a defective control unit may be the cause should all other components turn out to be serviceable.

Failure Symptom	Shows after ...s	Possible Causes
No start and no illumination of LED on control element	immediately	Wrong cabling, defective fuse
No start but LED illuminates	immediately	Fan or control unit defective or fan blocked
Very low speed with no start	immediately	Control idle operation: wrong manual control (selected temperature is below air intake temperature) or wrong integration (excessive air intake temperature)
Motor operates momentarily and then stops	1	Glow plug or flame sensor short or open circuit or control unit defective
Stoppage without run-down	5	Fan motor obstructed, binding
Run-down after	1	Flame detection erroneous
Run-down after	20	Voltage to control unit too low
Run-down after and dosing pump does not cycle	120	Cabling to dosing pump, pump itself or overheat protection defective
Run-down after	40 to 120	Intermittent disconnect of connection to dosing pump or to overheat protection
Run-down after	230	No flame: wrong fuel supply quantity, defective or slow fan, coked burner (in particular pilot flame outlet bore), combustion air/exhaust ducting obstructed or heat exchanger coked, dosing pump seized
Run-down	during combustion operation	Overheating or voltage too low or component error (flame sensor, glow plug, overheat sensor, dosing pump, burner) or no fuel supply or obstructed combustion air/exhaust ducting
Stoppage without run-down	during combustion operation	Fan motor failure or seizure
Interruption of dosing pump cycling and max. speed for 30 s with subsequent re-start	during combustion operation	Flame-out by gas bubbles in fuel delivery or strong wind against exhaust outlet or defective no-flame detection

Fig. 502 Failure Symptoms during Operation

**5.4 Error Code Output
(Air Top 2000 Diagnosis)**

When equipped with a combination or standard timer a malfunction will cause an error code output to the display of the timer for indication.

NOTE

When equipped with a control element the error code output is indicated by flashing of the operating indicator/ error code indication. The number of flash pulses corresponds to the number indicated in the table below. After a quick pulse train there will always be an error code output.

Error code output on display of combination or standard timer

F 01	No start (after 2 attempts)
F 02	Flame out (at least > 5)
F 03	Voltage too low or too high
F 04	Premature flame detection
F 05	Flame sensor open or short circuit
F 06	Temperature sensor open or short circuit
F 07	Dosing pump open or short circuit
F 08	Fan motor open or short circuit or wrong speed
F 09	Glow plug open or short circuit
F 10	Overheating

6 Functional Tests

6.1 General

This section describes the on-vehicle and off-vehicle testing of the air heater to check its proper operation.

WARNING

The air heater shall not be operated in enclosed areas like garages or workshops not provided with exhaust venting facilities.

6.2 Adjustments

6.2.1 Adjustment of the CO₂ Contents

6.2.1.1 General

The CO₂ contents of the exhaust is adjusted with the potentiometer on the control circuit board. The air heater is preset by the manufacturer with respect to the combustion and heating air fan fitted. After adjustment by the manufacturer the potentiometer is in center position (Fig. 601). After an inadvertent loss of this position it is sufficient to restore its original position.

The manufacturer setting may be corrected by rotating the potentiometer. A suitable tool like a small screw driver (2.5 mm tip) is to be used.

CAUTION

Set potentiometer slowly; observe end positions.

Adjustment may be performed at any electrical system voltage.

Clockwise rotation increases the fan speed and decreases the CO₂ contents. Counterclockwise rotation decreases the fan speed and increases the CO₂ contents.

If the setting range is not sufficient (e.g. after replacement of the combustion and heating air fan) the manufacturer's setting may be cancelled according to the procedure described in the following.

6.2.1.2 New Basic Setting

CAUTION

The manufacturer's setting cannot be restored.

1. Withdraw cover from upper shell according to 9.2.1.1.
2. Switch on air heater.
3. Rotate potentiometer two times and with no interrupt through its complete setting range (e.g. max. - min. - max.).
4. Adjust desired CO₂ contents (Fig. 601).
5. Switch off air heater.
6. Plug on cover and secure.

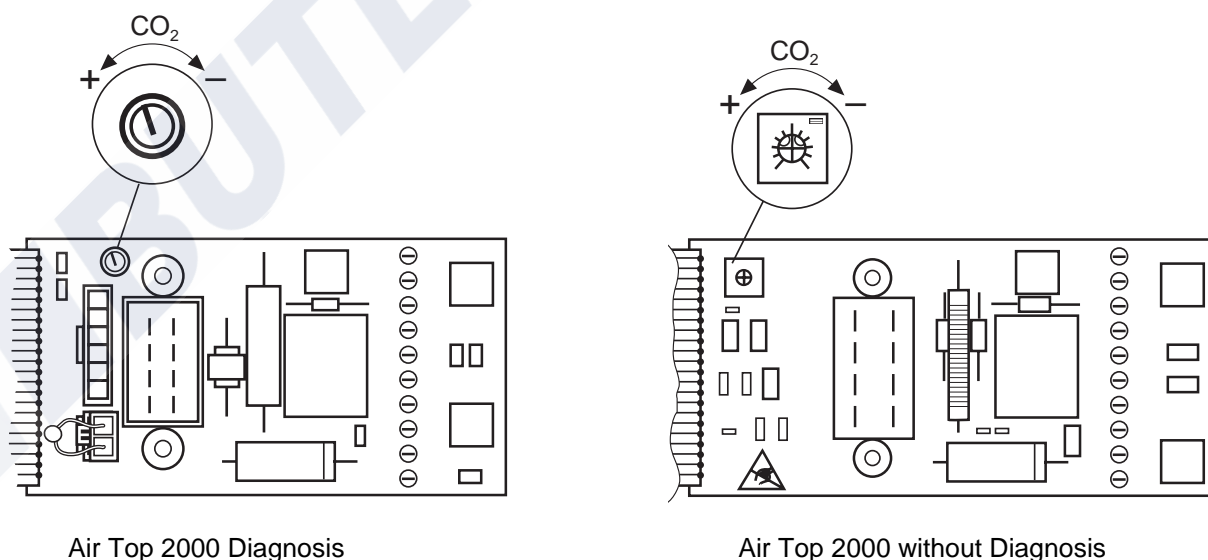

Fig. 601 Adjustment of CO₂ Contents

6.3 Components Testing

CAUTION

During electrical testing always ensure that the control unit and the component under test are electrically disconnected from each other.

6.3.1 Glow Plug Resistance Test

During electrical testing of the glow plug using a digital multimeter, the following readings should be obtained:

Glow plug:	12 Volt (red)	24 Volt (green)
Resistance at 25° C:	0.3 ... 0.6 Ω	1.3 ... 1.44 Ω
Test current:	< 5 mA	< 5 mA

6.3.2 Flame Sensor Resistance Test

During electrical testing of the flame sensor using a digital multimeter, the following readings should be obtained:

Cold test:

Resistance at 25° C:	2.6 ... 3.4 Ω
Test current:	< 5 mA

Hot test:

Resistance at 800 – 1000° C:	12 ... 15 Ω
(ceramic rod red hot over a length of approx. 20 mm)	
Test current:	< 5 mA

7 Circuit Diagrams

7.1 General

The air heater Air Top 2000 Diagnosis may be operated using the control element (rated value transmitter/switch) or with the control element and a combination or standard timer. The circuit diagrams (Figs. 703 to 708 and 714) show the possible circuits 12 or 24 Volt with

- control element
- combination timer
- control element and standard timer
- control element for ADR
- combination timer for ADR
- ADR operation for vehicles without auxiliary drive

Fig. 701 shows the terminal pin assignment.

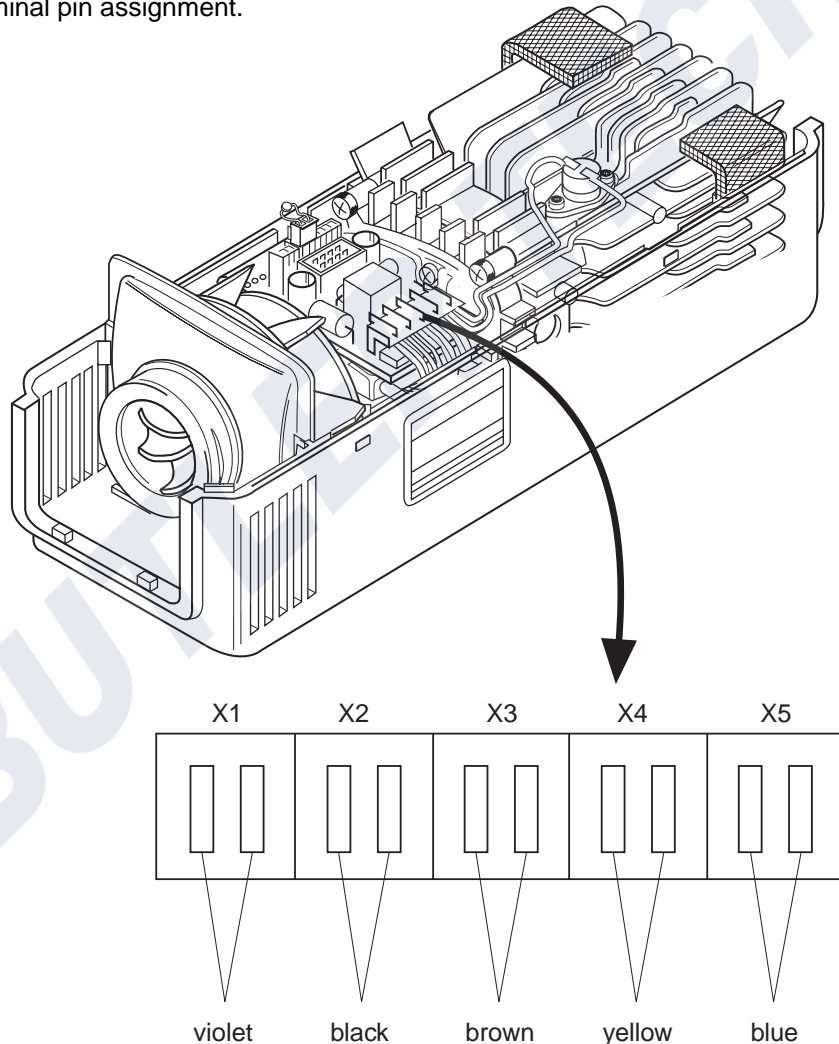

- X1 = Connection, Combustion and Heating Air Fan
 X2 = Connection, Dosing Pump
 X3 = Connection, Flame Sensor
 X4 = Connection, Glow Plug
 X5 = Connection, Temperature Limiter

Fig. 701 Terminal Pin Assignment, Air Top 2000 Diagnosis

The air heater Air Top 2000 without Diagnosis may be operated using the control element (rated value transmitter/switch) or with the control element and a timer. The circuit diagrams (Figs. 709 to 713) show the possible circuits 12 or 24 Volt with

- control element
- control element and timer
- control element for ADR

Fig. 702 shows the terminal pin assignment.

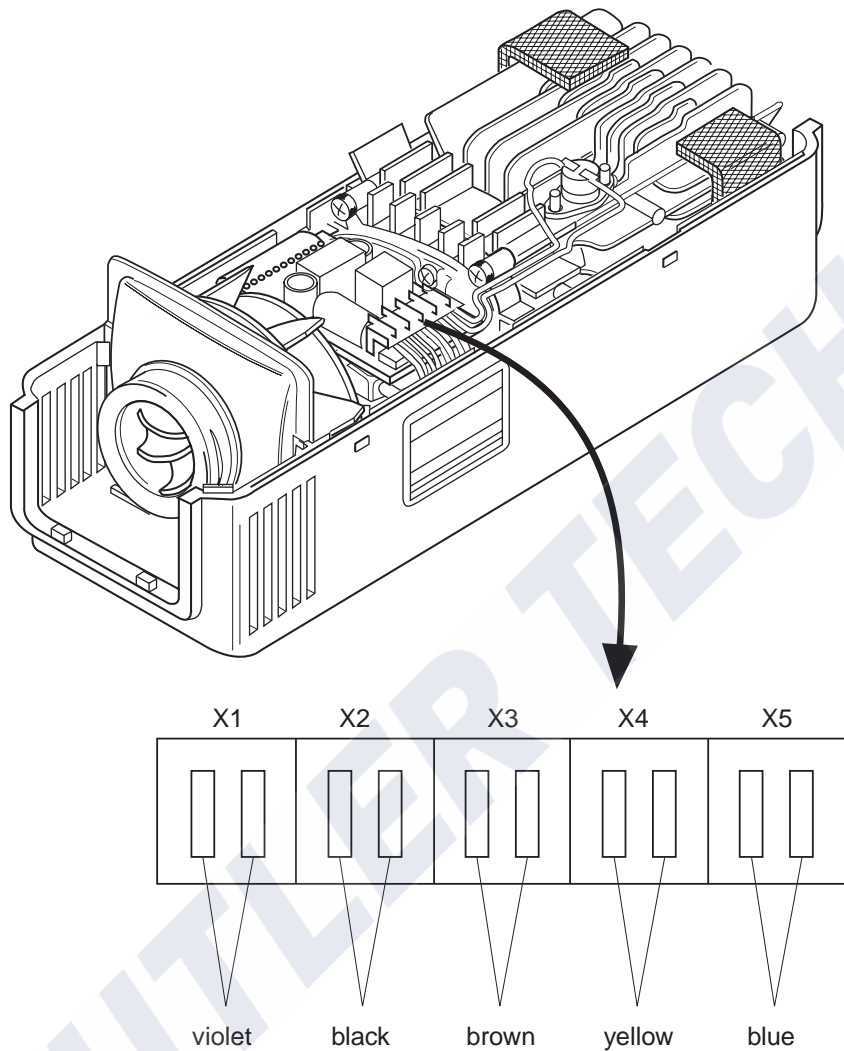

- X1 = Connection, Combustion and Heating Air Fan
- X2 = Connection, Dosing Pump
- X3 = Connection, Flame Sensor
- X4 = Connection, Glow Plug
- X5 = Connection, Temperature Limiter

Fig. 702 Terminal Pin Assignment, Air Top 2000 without Diagnosis

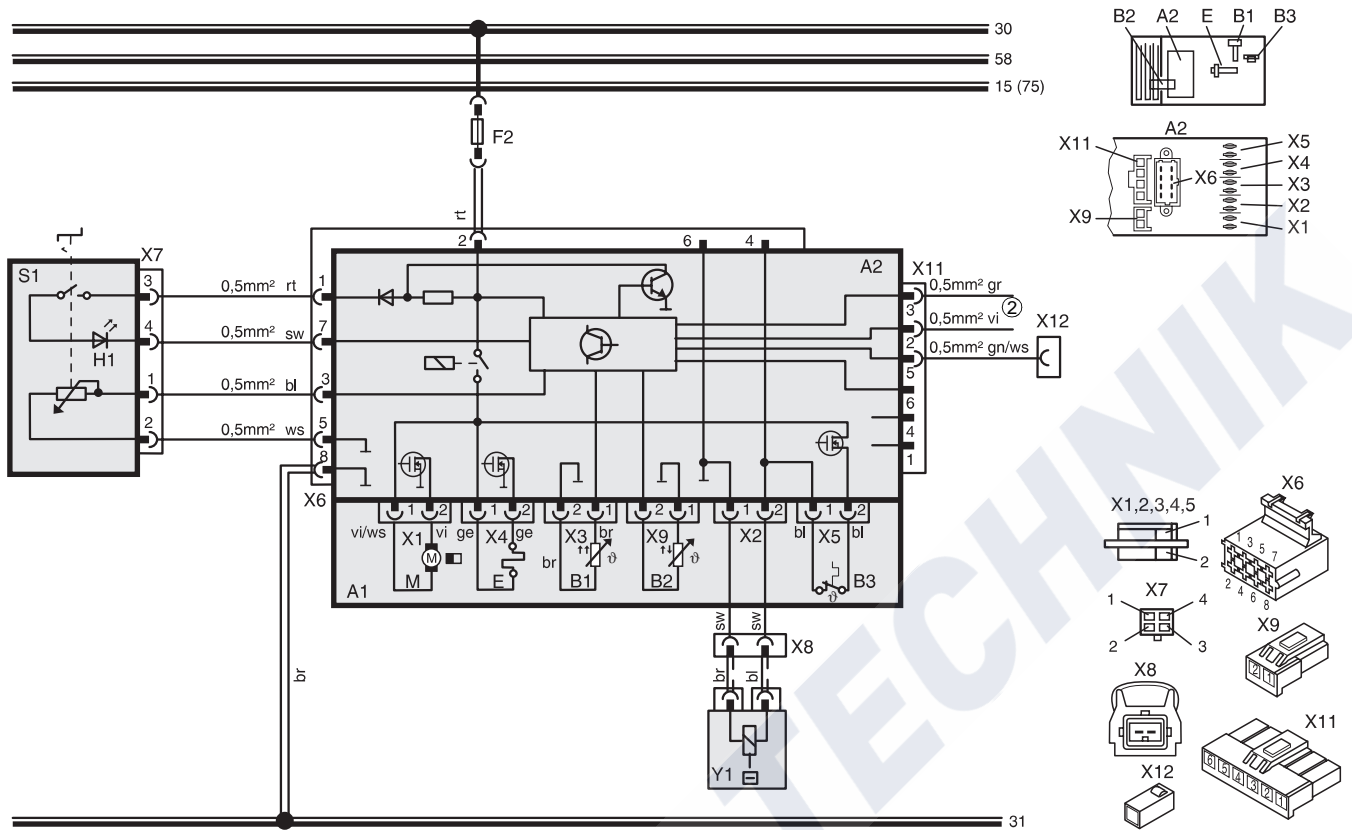

Item	Nomenclature	Remark
A1	Air Heater	Air Top 2000
A2	Control Unit	
B1	Flame Sensor	
B2	Temperature Sensor	
B3	Temperature Limiter	
E	Glow Plug	
F2	Fuse 24V 10A/12V 15A	Flat Fuse SAE J 1284
H1	LED green (in item S1)	Operation indication
M	Motor	
S1	Control Element	Rated Value Setting Switch
X1-X5	Connection 2-pole	of item A2
X6	Connection 8-pole	of item A2
X7	Connection 4-pole	of item S1
X8	Connection 2-pole	
X9	Connection 2-pole	of item A2
X11	Connection 6-pole	of item A2
X12	Connection 1-pole	Diagnosis (K-wire)
Y1	Dosing Pump	

Wire Gauges		
	< 7.5 m	7.5 - 15 m
	0.75 mm ²	1.5 mm ²
	1.0 mm ²	1.5 mm ²
	1.5 mm ²	2.5 mm ²
	2.5 mm ²	4.0 mm ²
	4.0 mm ²	6.0 mm ²

Wire Colours	
bl	blue
br	brown
ge	yellow
gn	green
gr	grey
or	orange
rt	red
sw	black
vi	violet
ws	white

② Connection X11/2 and X11/3 for ADR function only

Fig. 703 Circuit Diagram Automatic Control Air Top 2000 Diagnosis, 12V/24V with Control Element

7 Circuit Diagrams

Air Top 2000

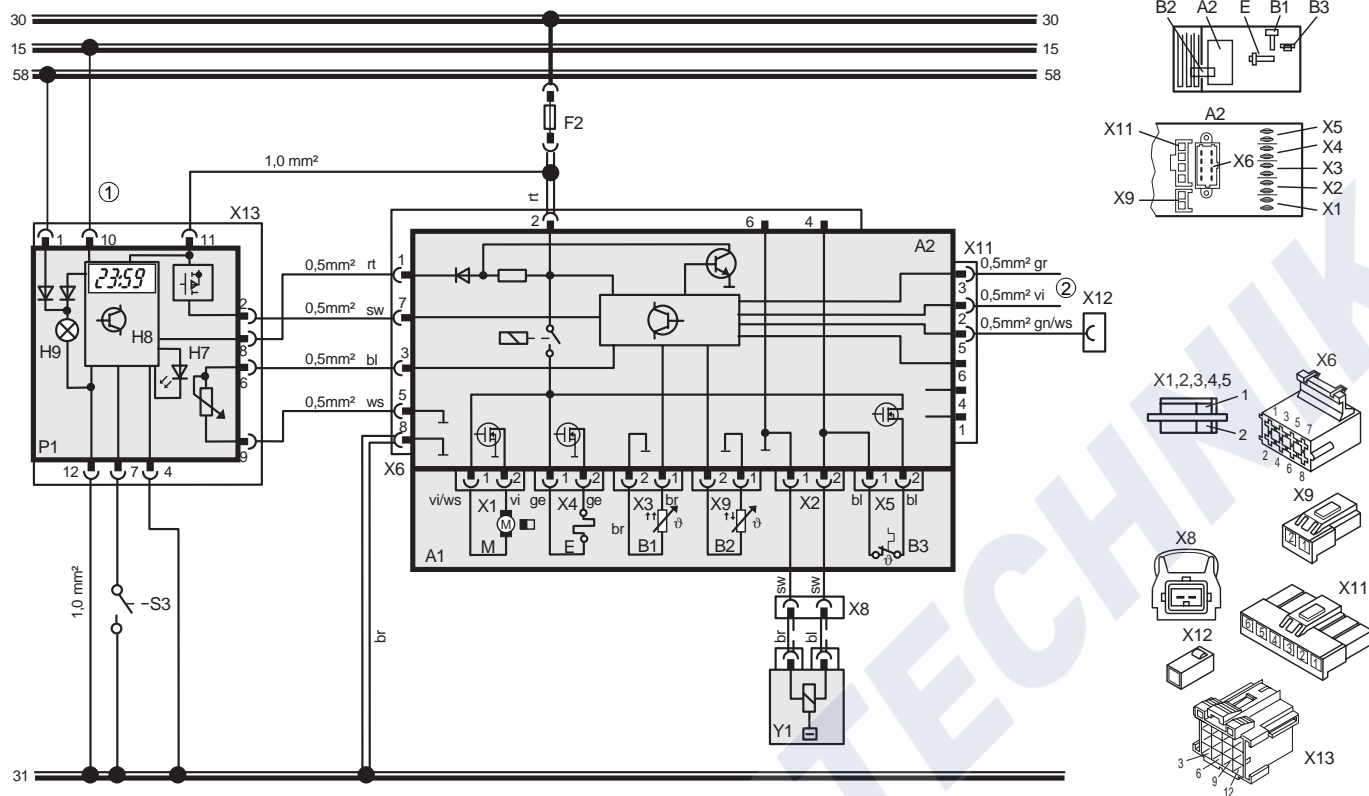

Item	Nomenclature	Remark
A1	Air Heater	Air Top 2000
A2	Control Unit	
B1	Flame Sensor	
B2	Temperature Sensor	
B3	Temperature Limiter	
E	Glow Plug	
F2	Fuse 24V 10A/12V 15A	Flat Fuse SAE J 1284
H7	LED red (in item P)	Instant heat switch illumination, standby indication, operating indicator light
H8	LED (in item P)	Operating indicator light, overheat indication
H9	Light (in item P)	Symbol illumination
M	Motor	
P1	Combination Timer (1531)	
S3	Switch	Instant heating remote control
X1-X5	Connection 2-pole	of item A2
X6	Connection 8-pole	of item A2
X8	Connection 2-pole	
X9	Connection 2-pole	of item A2
X11	Connection 6-pole	of item A2
X12	Connection 1-pole	Diagnosis (K-wire)
X13	Connection 12-pole	of item P
Y1	Dosierpumpe	

Wire Gauges		
	< 7.5 m	7.5 - 15 m
	0.75 mm ²	1.5 mm ²
	1.0 mm ²	1.5 mm ²
	1.5 mm ²	2.5 mm ²
	2.5 mm ²	4.0 mm ²
	4.0 mm ²	6.0 mm ²

Wire Colours	
bl	blue
br	brown
ge	yellow
gn	green
gr	grey
or	orange
rt	red
sw	black
vi	violet
ws	white

- ① with plus from terminal (15/75) to connection 10: permanent operation during instant heating as long as ignition on
- without plus to connection 10: heating time programmable as required (10 min to 120 min), default setting 120 min.
- ② Connection X11/2 and X11/3 for ADR function only

Fig. 704 Circuit Diagram Automatic Control Air Top 2000 Diagnosis, 12V/24V with Combination Timer

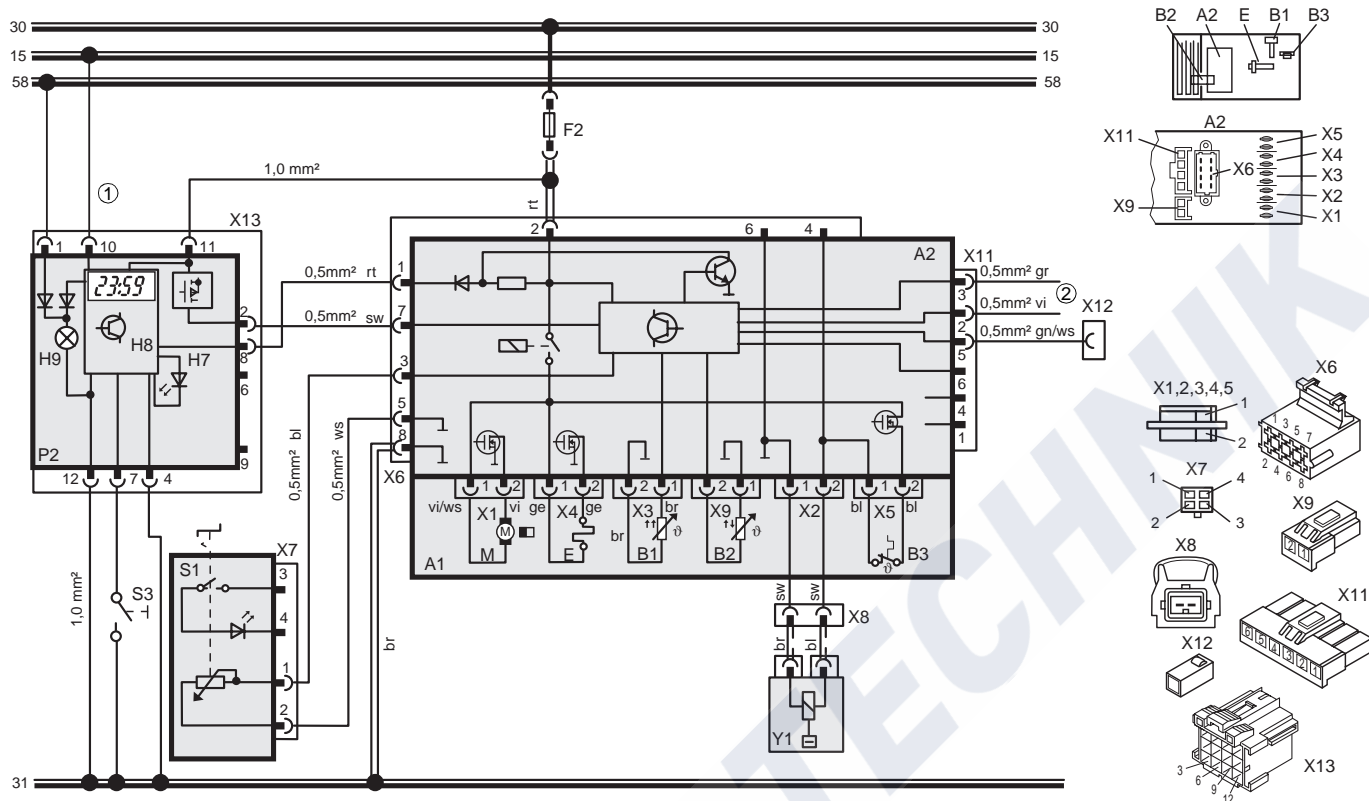

Item	Nomenclature	Remark
A1	Air Heater	Air Top 2000
A2	Control Unit	
B1	Flame Sensor	
B2	Temperature Sensor	
B3	Temperature Limiter	
E	Glow Plug	
F2	Fuse 24V 10A/12V 15A	Flat Fuse SAE J 1284
H7	LED red (in item P)	Instant heat switch illumination, standby indication, operating indicator light
H8	Heating symbol in display (in item P)	Operating indicator light, overheat indication
H9	Light (in item P)	Symbol illumination
M	Motor	
P2	Standard timer	
S1	Control Element	Rated Value Setting Switch
S3	Switch	Instant heating remote control
X1-X5	Connection 2-pole	of item A2
X6	Connection 8-pole	of item A2
X7	Connection 4-pole	of item S1
X8	Connection 2-pole	
X11	Connection 6-pole	of item A2
X12	Connection 1-pole	Diagnosis (K-wire)
X13	Connection 12-pole	of item P
Y1	Dosing Pump	

Wire Gauges		
	< 7.5 m	7.5 - 15 m
	0.75 mm ²	1.5 mm ²
	1.0 mm ²	1.5 mm ²
	1.5 mm ²	2.5 mm ²
	2.5 mm ²	4.0 mm ²
	4.0 mm ²	6.0 mm ²

Wire Colours	
bl	blue
br	brown
ge	yellow
gn	green
gr	grey
or	orange
rt	red
sw	black
vi	violet
ws	white

① with plus from terminal (15/75) to connection 10: permanent operation during instant heating as long as ignition on

without plus to connection 10: heating time programmable as required (10 min to 120 min), default setting 120 min.

② Connection X11/2 and X11/3 for ADR function only

Fig. 705 Circuit Diagram Automatic Control Air Top 2000 Diagnosis, 12V/24V with Control Element and Standard Timer

7 Circuit Diagrams

Air Top 2000

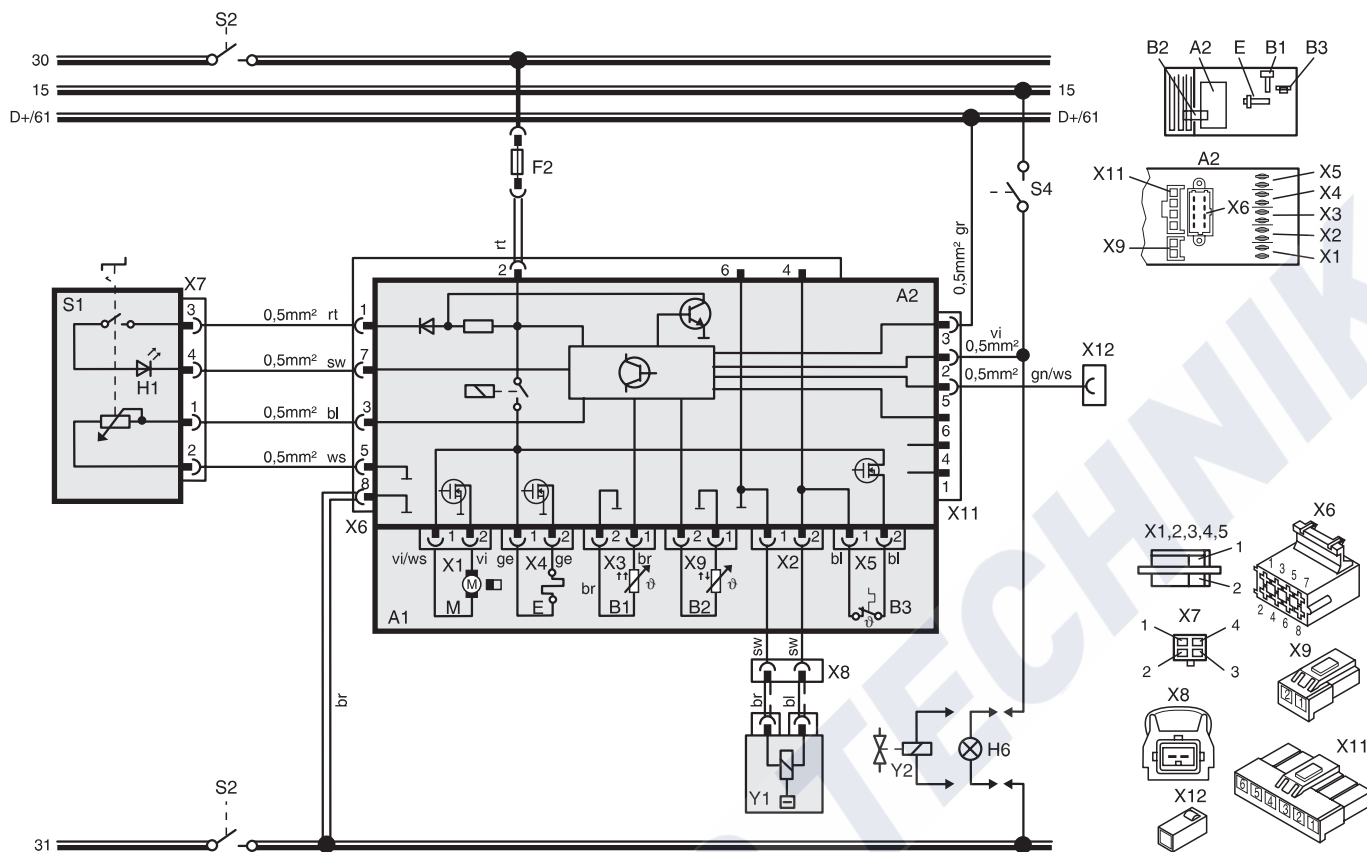

Item	Nomenclature	Remark
A1	Air Heater	Air Top 2000
A2	Control Unit	
B1	Flame Sensor	
B2	Temperature Sensor	
B3	Temperature Limiter	
E	Glow Plug	
F2	Fuse 24V 10A	Flat Fuse SAE J 1284
H1	LED green (in item S1)	Operation indication
H6	Light (at least 1.2 W)	Operation indication, conveyor facility
M	Motor	
S1	Rated Value Setting Switch	Control Element
S2	Disconnect Switch 1- oder 2-pole	Emergency-off Switch; electr. or pneum.
S4	Switch	Conveyor facility I
X1-X5	Connection 2-pole	of item A2
X6	Connection 8-pole	of item A2
X7	Connection 4-pole	of item S1
X8	Connection 2-pole	
X9	Connection 2-pole	of item A2
X11	Connection 6-pole	of item A2
X12	Connection 1-pole	Diagnosis (K-wire)
Y1	Dosing Pump	
Y2	Solenoid valve	for conveyor facility I

Wire Gauges		
	< 7.5 m	7.5 - 15 m
	0.75 mm ²	1.5 mm ²
	1.0 mm ²	1.5 mm ²
	1.5 mm ²	2.5 mm ²
	2.5 mm ²	4.0 mm ²
	4.0 mm ²	6.0 mm ²

Wire Colours	
bl	blue
br	brown
ge	yellow
gn	green
gr	grey
or	orange
rt	red
sw	black
vi	violet
ws	white

Fig. 706 Circuit Diagram Automatic Control Air Top 2000 Diagnosis, 24V ADR Operation with Control Element

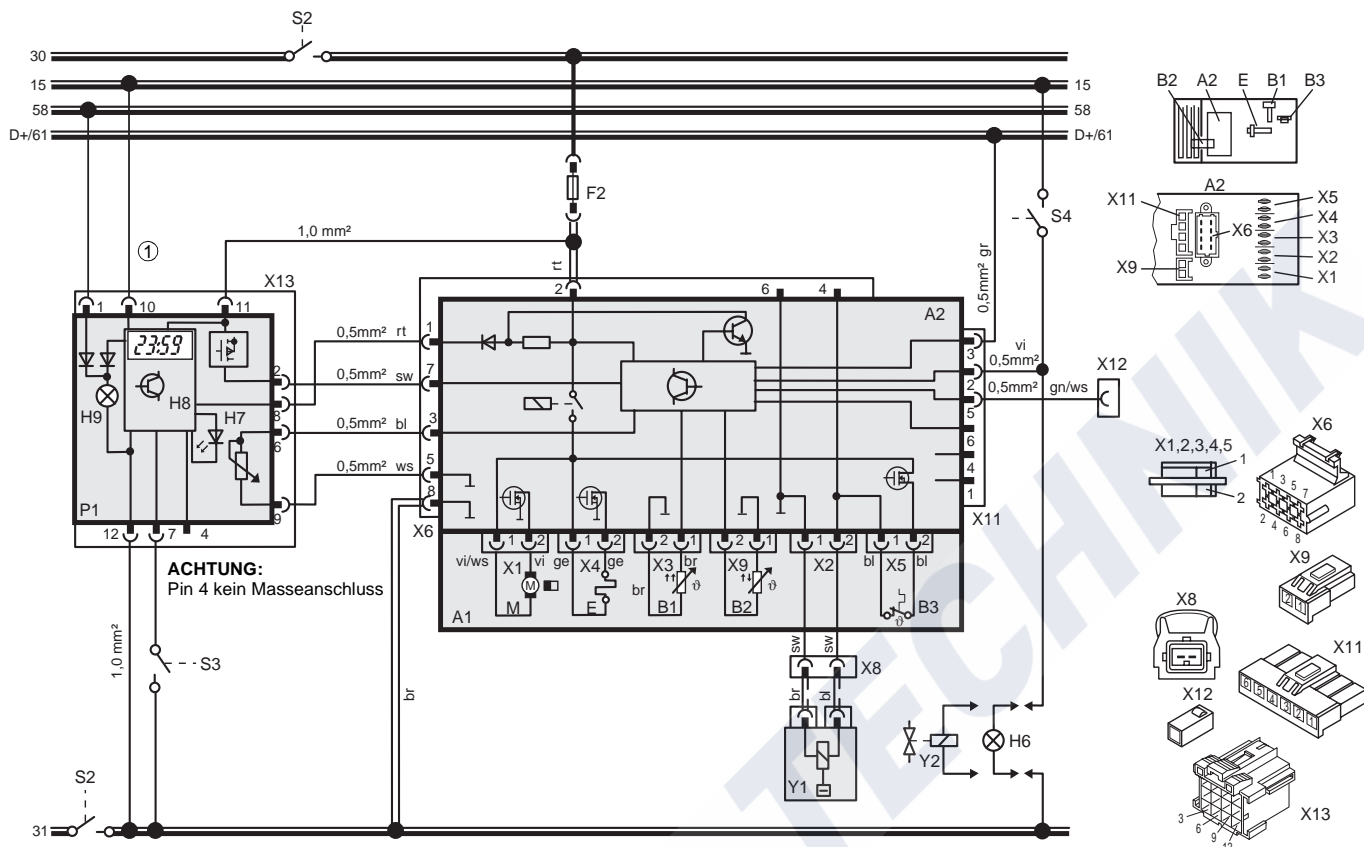

Item	Nomenclature	Remark
A1	Air Heater	Air Top 2000
A2	Control Unit	
B1	Flame Sensor	
B2	Temperature Sensor	
B3	Temperature Limiter	
E	Glow Plug	
F2	Fuse 24V 10A	Flat Fuse SAE J 1284
H6	Light (at least 1.2 W)	Operation indication, conveyor facility
H7	LED red (in item P)	Instant heat switch illumination, standby indication, operating indicator light
H8	Heating symbol in display (in item P)	Operating indicator light, overheat indication
H9	Light (in item P)	Symbol illumination
M	Motor	
P1	Combination Timmer (1531)	
S2	Disconnect Switch 1- oder 2-pole	Emergency-off Switch; electr. or pneum.
S3	Switch	Instant heating remote control
S4	Switch	Conveyor facility I
X1-X5	Connection 2-pole	of item A2
X6	Connection 8-pole	of item A2
X8	Connection 2-pole	
X9	Connection 2-pole	of item A2
X11	Connection 6-pole	of item A2
X12	Connection 1-pole	Diagnosis (K-wire)
X13	Connection 12-pole	of item P
Y1	Dosing Pump	
Y2	Solenoid valve	for conveyor facility I

Wire Gauges		
	< 7.5 m	7.5 - 15 m
	0.75 mm ²	1.5 mm ²
	1.0 mm ²	1.5 mm ²
	1.5 mm ²	2.5 mm ²
	2.5 mm ²	4.0 mm ²
	4.0 mm ²	6.0 mm ²

Wire Colours	
bl	blue
br	brown
ge	yellow
gn	green
gr	grey
or	orange
rt	red
sw	black
vi	violet
ws	white

① with plus from terminal (15/75) to connection 10: permanent operation during instant heating as long as ignition on

without plus to connection 10: heating time programmable as required (10 min to 120 min), default setting 120 min.

Fig. 707 Circuit Diagram Automatic Control Air Top 2000 Diagnosis, 24V ADR Operation with Combination Timer

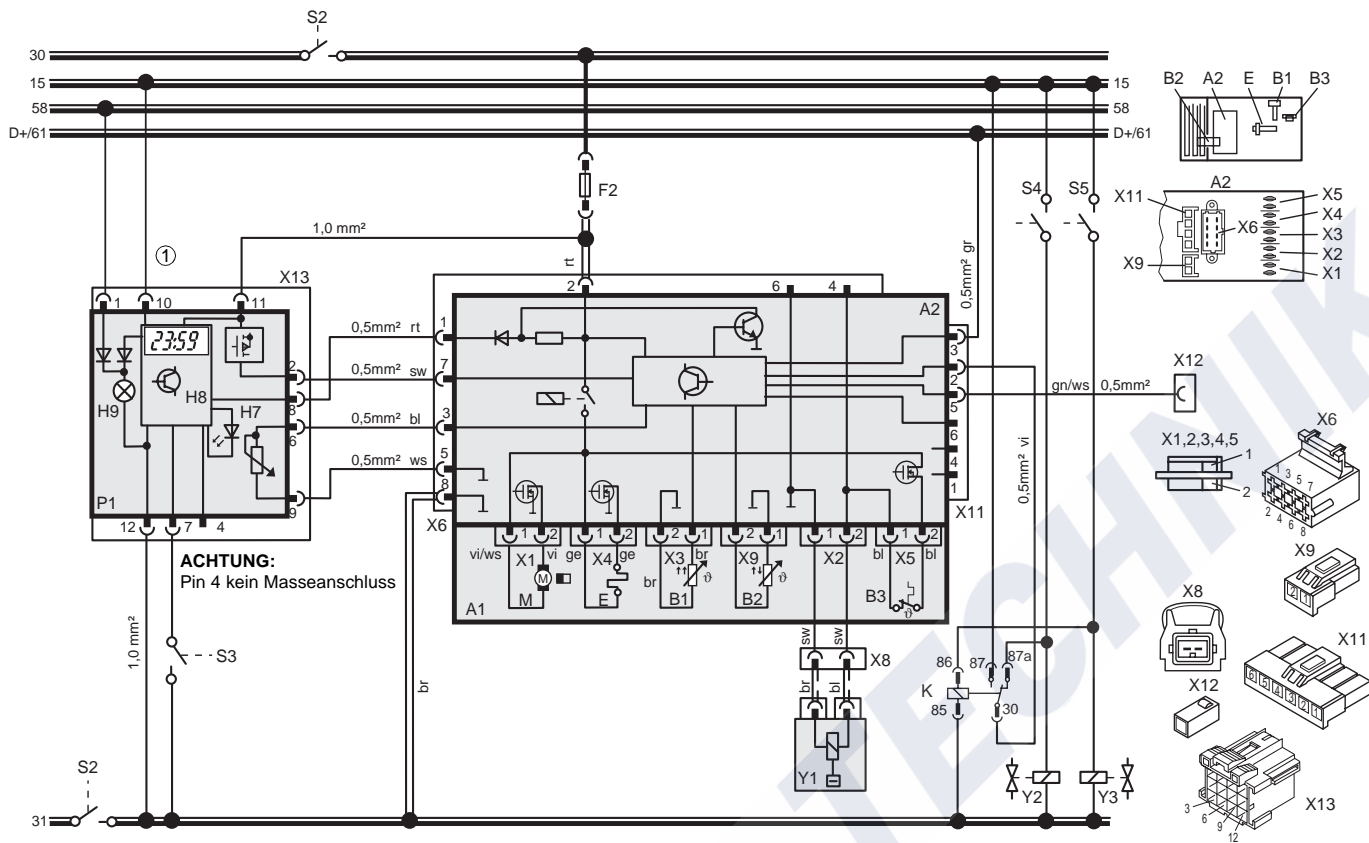

Item	Nomenclature	Remark
A1	Air Heater	Air Top 2000
A2	Control Unit	
B1	Flame Sensor	
B2	Temperature Sensor	
B3	Temperature Limiter	
E	Glow Plug	
F2	Fuse 24V 10A/12V 15A	Flat Fuse SAE J 1284
H7	LED red (in item P)	Instant heat switch illumination, standby indication, operating indicator light
H8	Heating symbol in display (in item P)	Operating indicator light, overheat indication
H9	Light (in item P)	Symbol illumination
M	Motor	
P1	Combination Timer (1531)	
S2	Disconnect Switch 1- or 2-pole	Emergency-off Switch; electr. or pneum.
S3	Switch	Instant heating remote control
S4	Switch	Conveyor facility I
S5	Switch	Conveyor facility II
X1-X5	Connection 2-pole	of item A2
X6	Connection 8-pole	of item A2
X8	Connection 2-pole	
X9	Connection 2-pole	an Pos. A2
X11	Connection 6-pole	an Pos. A2
X12	Connection 1-pole	Diagnosis (K-wire)
X13	Connection 12-pole	of item P
Y1	Dosing Pump	
Y2	Solenoid valve	for conveyor facility I
Y3	Solenoid valve	for conveyor facility II

Wire Gauges	
	< 7.5 m
	7.5 - 15 m
	0.75 mm²
	1.5 mm²
	1.0 mm²
	1.5 mm²
	2.5 mm²
	4.0 mm²

Wire Colours	
bl	blue
br	brown
ge	yellow
gn	green
gr	grey
or	orange
rt	red
sw	black
vi	violet
ws	white

NOTE
 Minus potential applied to control unit input X11/2 (ADR identification) across Y2 and K

① with plus from terminal (15/75) to connection 10: permanent operation during instant heating as long as ignition on

without plus to connection 10: heating time programmable as required (10 min to 120 min), default setting 120 min.

Fig. 708 Circuit Diagram Automatic Control Air Top 2000 Diagnosis, 24V ADR Operation with Combination Timer and 2 Auxiliary Drives

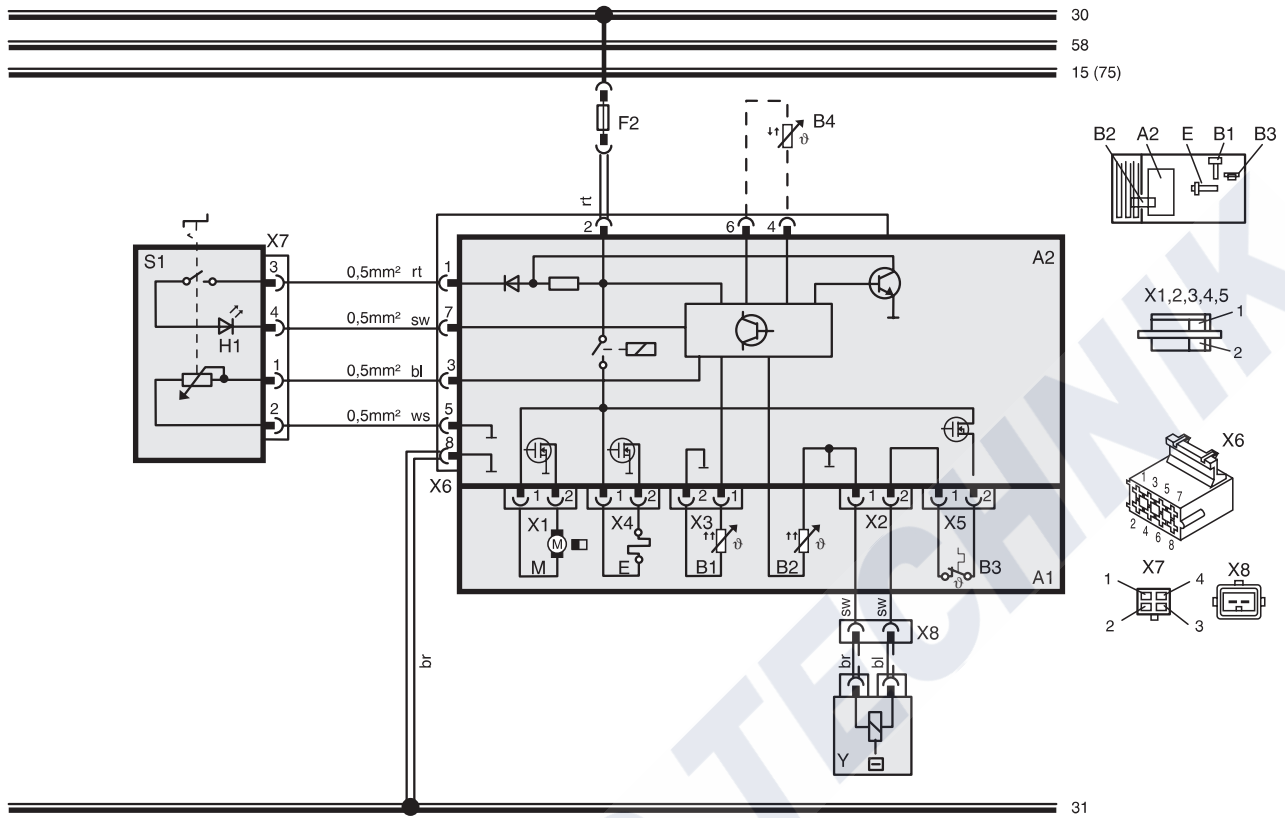

Item	Nomenclature	Remark
A1	Air Heater	Air Top 2000
A2	Control Unit	
B1	Flame Sensor	
B2	Temperature Sensor	
B3	Temperature Limiter	
B4	Temperature Sensor	
E	Glow Plug	
F2	Fuse 15A	Flat Fuse SAE J 1284
H1	LED green (in item S1)	Operation indication
H4	Leuchten (in item P)	Symbol illumination
M	Motor	
S1	Rated Value Setting Switch	Control Element
X1-X5	Connection 2-pole	of item A2
X6	Connection 8-pole	of item A2
X7	Connection 4-pole	of item S
X8	Connection 2-pole	
Y	Dosing Pump	

Wire Gauges		
	< 7.5 m	7.5 - 15 m
	0.75 mm ²	1.5 mm ²
	1.0 mm ²	1.5 mm ²
	1.5 mm ²	2.5 mm ²
	2.5 mm ²	4.0 mm ²
	4.0 mm ²	6.0 mm ²

Wire Colours	
bl	blue
br	brown
ge	yellow
gn	green
gr	grey
or	orange
rt	red
sw	black
vi	violet
ws	white

Fig. 709 Circuit Diagram Automatic Control Air Top 2000 without Diagnosis, 12V with Control Element

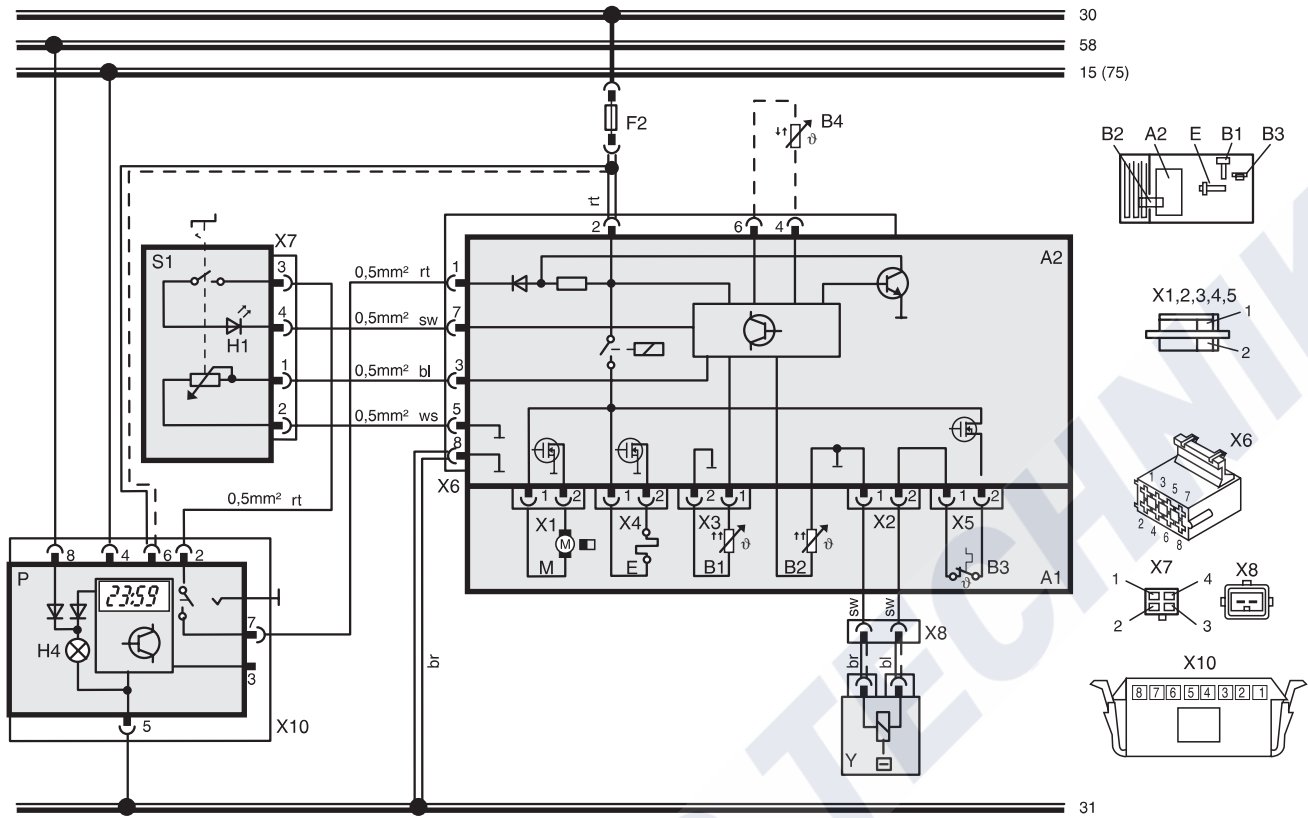

Item	Nomenclature	Remark
A1	Air Heater	Air Top 2000
A2	Control Unit	
B1	Flame Sensor	
B2	Temperature Sensor	
B3	Temperature Limiter	
B4	Temperature Sensor	
E	Glow Plug	
F2	Fuse 15A	Flat Fuse SAE J 1284
H1	LED green (in item S1)	Operation indication
H4	Light (in item P)	Symbol illumination
M	Motor	
P	Timer 1529	for pre-timed operation
S1	Rated Value Setting Switch	Control Element
X1-X5	Connection 2-pole	of item A2
X6	Connection 8-pole	of item A2
X7	Connection 4-pole	of item S
X8	Connection 2polig	
X10	Connection 8-pole	
Y	Dosing Pump	



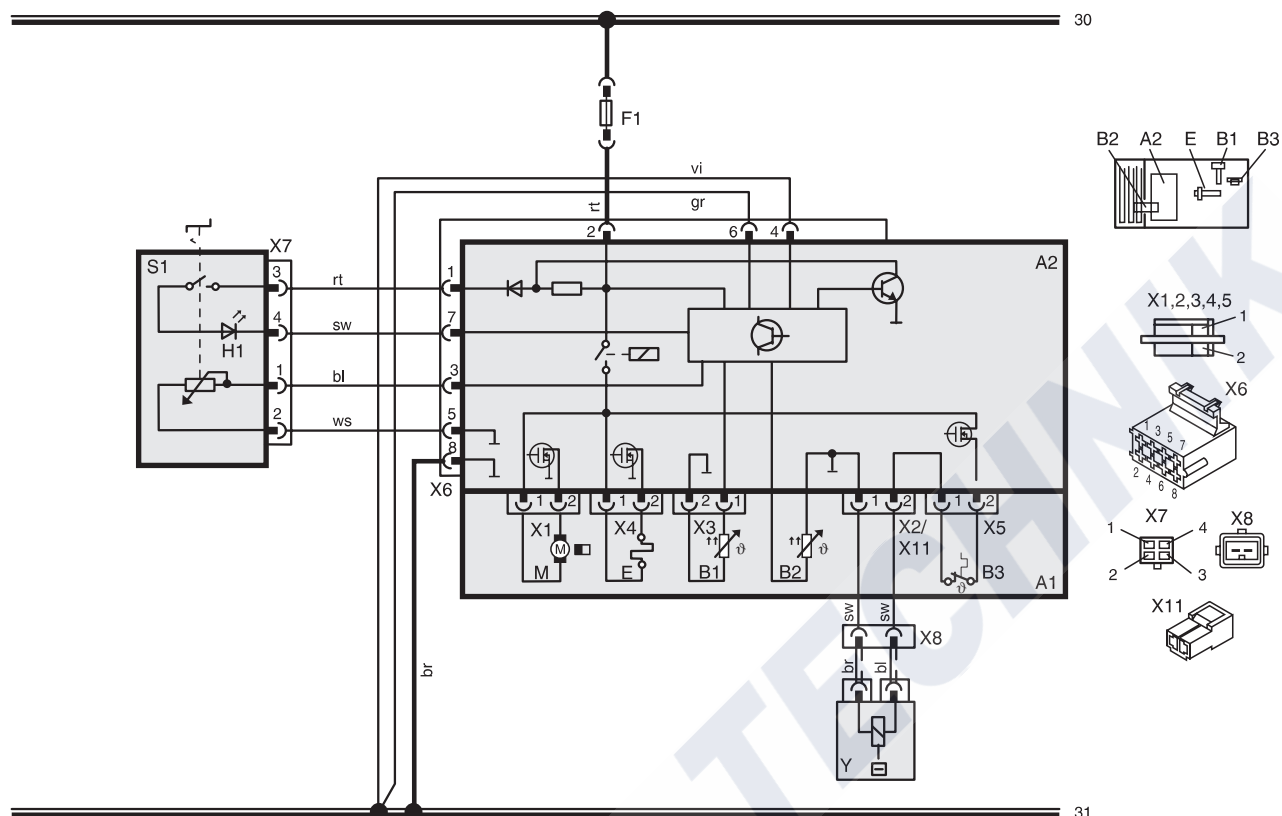

Wire Gauges		
	< 7.5 m	7.5 - 15 m
	0.75 mm ²	1.5 mm ²
	1.0 mm ²	1.5 mm ²
	1.5 mm ²	2.5 mm ²
	2.5 mm ²	4.0 mm ²
	4.0 mm ²	6.0 mm ²

Wire Colours	
bl	blue
br	brown
ge	yellow
gn	green
gr	grey
or	orange
rt	red
sw	black
vi	violet
ws	white

Fig. 710 Circuit Diagram Automatic Control Air Top 2000 without Diagnosis, 12V with Control Element and Timer



Item	Nomenclature	Remark
A1	Air Heater	Air Top 2000
A2	Control Unit	
B1	Flame Sensor	
B2	Temperature Sensor	
B3	Temperature Limiter	
E	Glow Plug	
F1	Fuse 10A	Flat Fuse SAE J 1284
H1	LED green (in item S1)	Operation indication
M	Motor	
S1	Rated Value Setting Switch	Control Element
X1-X5	Connection 2-pole	of item A2
X6	Connection 8-pole	of item A2
X7	Connection 4-pole	of item S
X8	Connection 2-pole	
X11	Connection 2-pole	for manufacturer's installations only
Y	Dosing Pump	

Wire Gauges		
	< 7.5 m	7.5 - 15 m
	0.75 mm ²	1.5 mm ²
	1.0 mm ²	1.5 mm ²
	1.5 mm ²	2.5 mm ²
	2.5 mm ²	4.0 mm ²
	4.0 mm ²	6.0 mm ²

Wire Colours	
bl	blue
br	brown
ge	yellow
gn	green
gr	grey
or	orange
rt	red
sw	black
vi	violet
ws	white

Fig. 711 Circuit Diagram Automatic Control Air Top 2000 without Diagnosis, 24V with Control Element

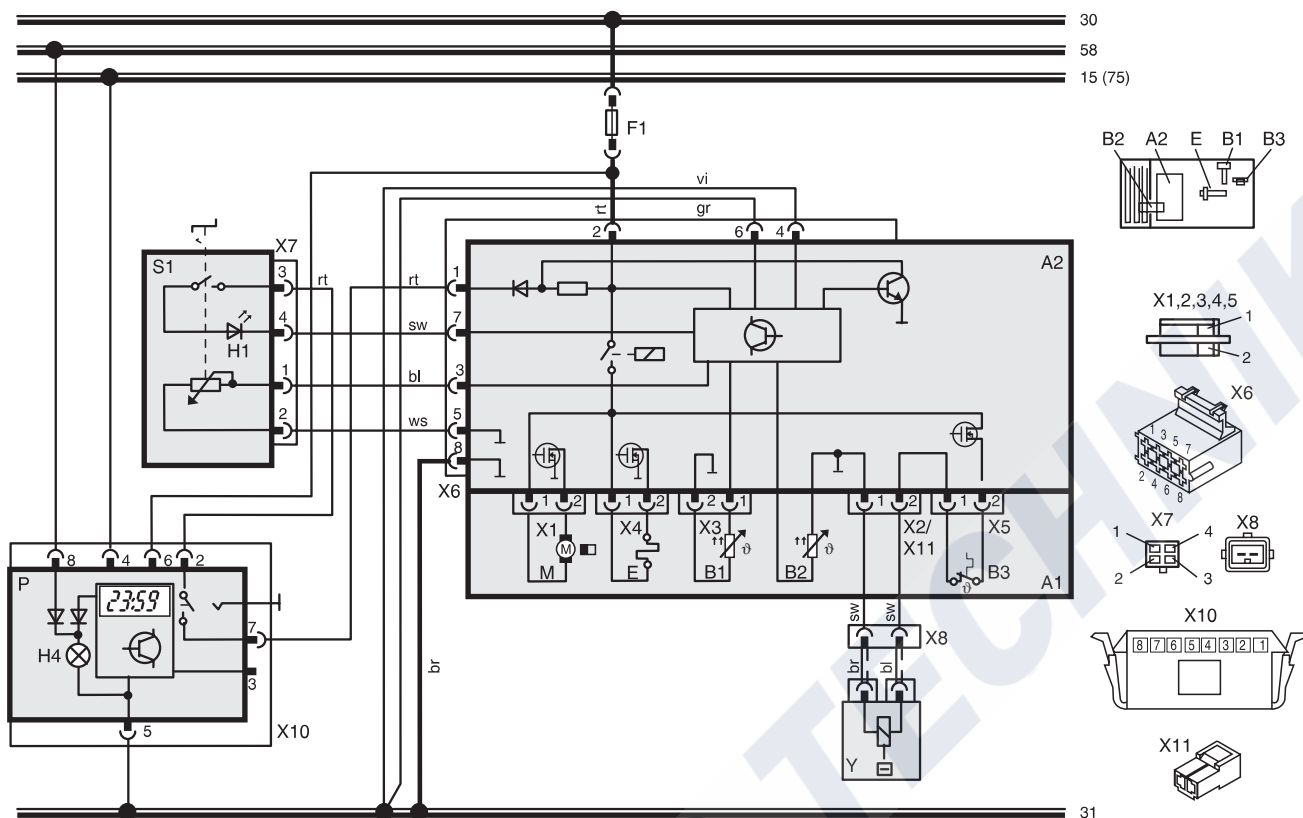

Item	Nomenclature	Remark
A1	Air Heater	Air Top 2000
A2	Control Unit	
B1	Flame Sensor	
B2	Temperature Sensor	
B3	Temperature Limiter	
E	Glow Plug	
F1	Fuse 10A	Flat Fuse SAE J 1284
H1	LED green (in item S1)	Operation indication
H4	Light (in item P)	Symbol illumination
M	Motor	
P	Timer 1529	for pre-timed operation
S1	Rated Value Setting Switch	Control Element
X1-X5	Connection 2-pole	of item A2
X6	Connection 8-pole	of item A2
X7	Connection 4-pole	of item S
X8	Connection 2-pole	
X10	Connection 8-pole	
X11	Connection 2-pole	for manufacturer's installations only
Y	Dosing Pump	

Wire Gauges		
	< 7.5 m	7.5 - 15 m
	0.75 mm ²	1.5 mm ²
	1.0 mm ²	1.5 mm ²
	1.5 mm ²	2.5 mm ²
	2.5 mm ²	4.0 mm ²
	4.0 mm ²	6.0 mm ²

Wire Colours	
bl	blue
br	brown
ge	yellow
gn	green
gr	grey
or	orange
rt	red
sw	black
vi	violet
ws	white

Fig. 712 Circuit Diagram Automatic Control Air Top 2000 without Diagnosis, 24V with Control Element and Timer

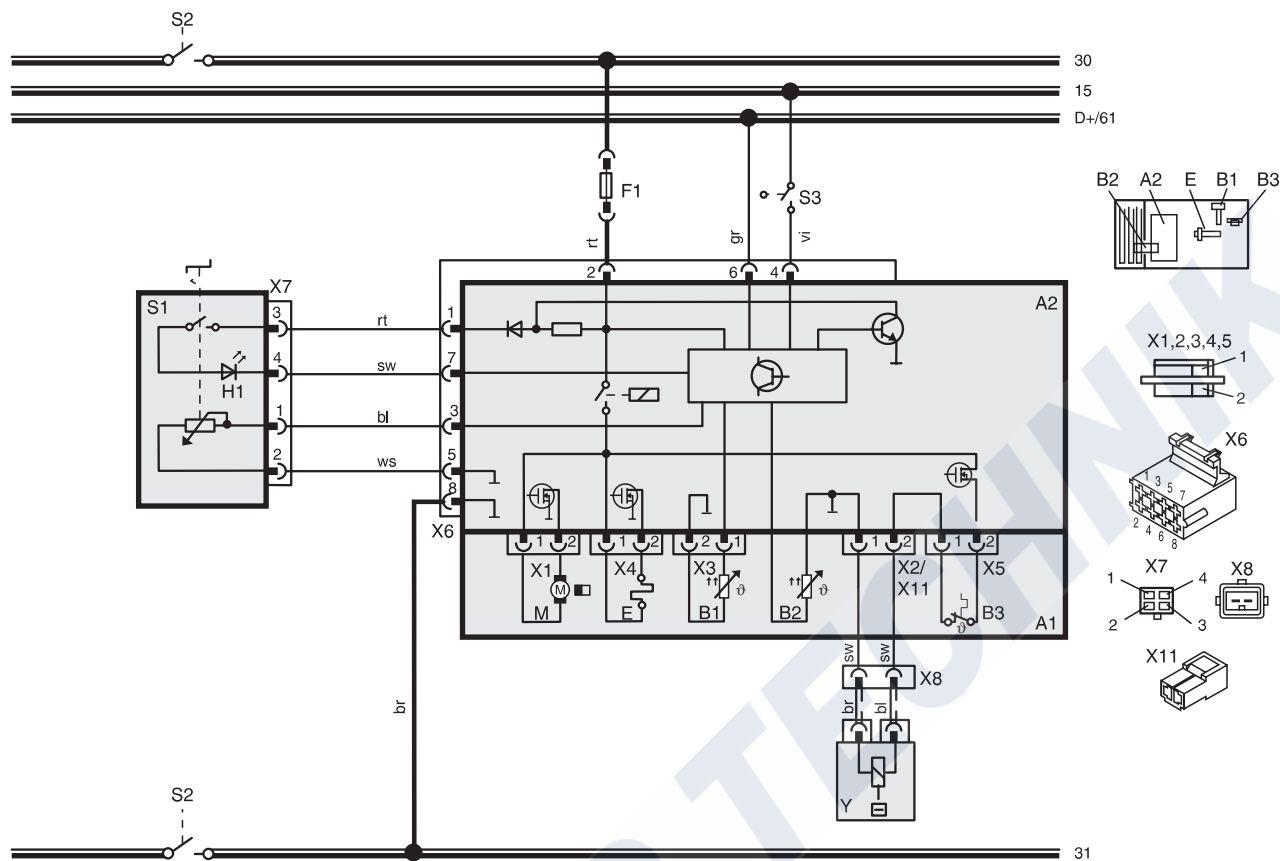

Item	Nomenclature	Remark
A1	Air Heater	Air Top 2000
A2	Control Unit	
B1	Flame Sensor	
B2	Temperature Sensor	
B3	Temperature Limiter	
E	Glow Plug	
F1	Fuse 10A	Flat Fuse SAE J 1284
H1	LED green (in item S1)	Operation indication
M	Motor	
S1	Rated Value Setting Switch	Control Element
S2	Disconnect Switch 1- or 2-pole	Emergency-off Switch; electr. or pneum.
X1-X5	Connection 2-pole	of item A2
X6	Connection 8-pole	of item A2
X7	Connection 4-pole	of item S
X8	Connection 2-pole	
X11	Connection 2-pole	for manufacturer's installations only
Y	Dosing Pump	

Wire Gauges		
	< 7.5 m	7.5 - 15 m
	0.75 mm ²	1.5 mm ²
	1.0 mm ²	1.5 mm ²
	1.5 mm ²	2.5 mm ²
	2.5 mm ²	4.0 mm ²
	4.0 mm ²	6.0 mm ²

Wire Colours	
bl	blue
br	brown
ge	yellow
gn	green
gr	grey
or	orange
rt	red
sw	black
vi	violet
ws	white

Fig. 713 Circuit Diagram Automatic Control Air Top 2000 without Diagnosis, 24V with Control Element, ADR

7 Circuit Diagrams

Air Top 2000

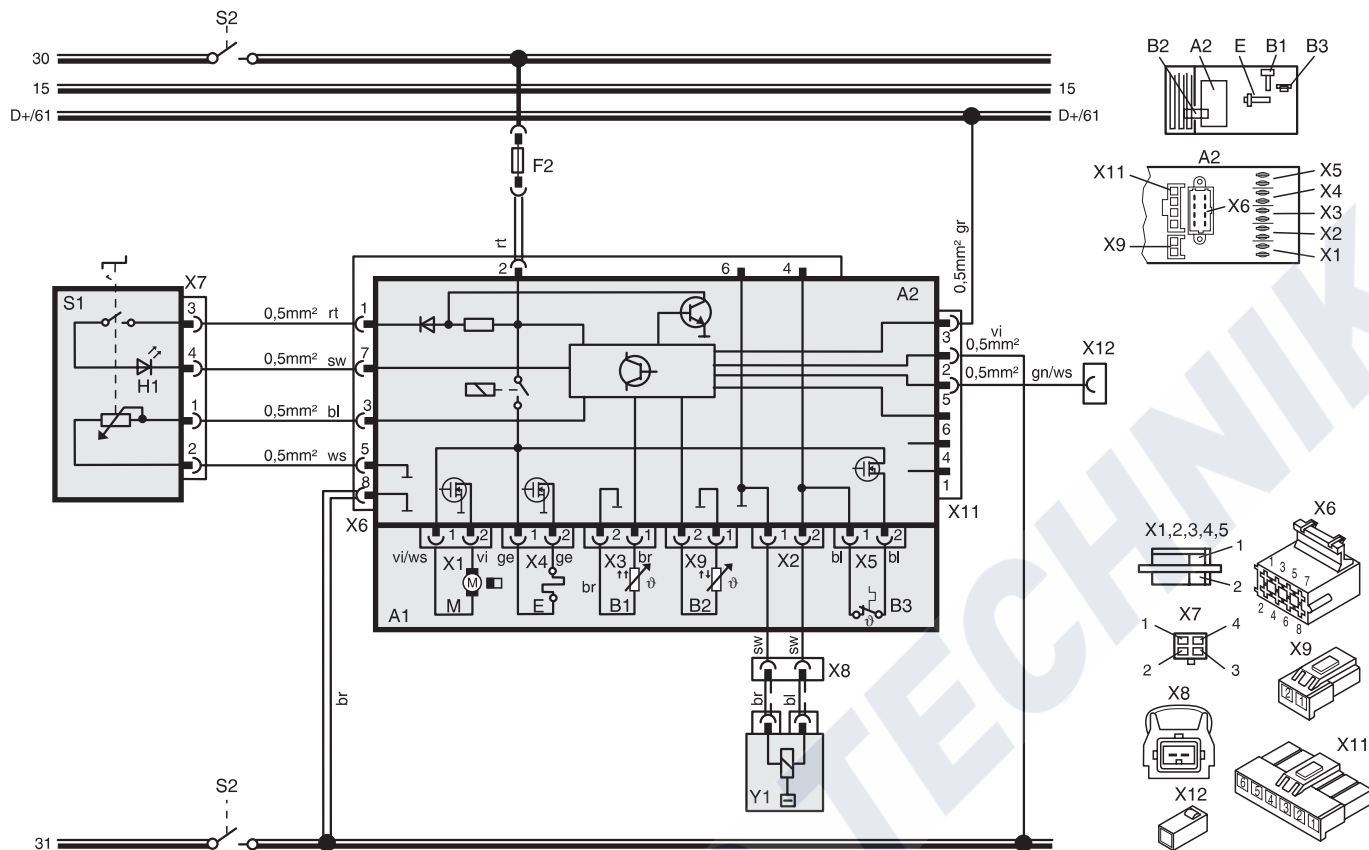

Item	Nomenclature	Remark
A1	Air Heater	Air Top 2000
A2	Control Unikt	
B1	Flame Sensor	
B2	Temperature Sensor	
B3	Temperature Limiter	
E	Glow Plug	
F1	Fuse 10A	Flat Fuse SAE J 1284
H1	LED green (in item S1)	Operation indication
M	Motor	
S1	Rated Value Setting Switch	Control Element
S2	Disconnect Switch 1- or 2-pole	Emergency-off Switch; electr. or pneum.
X1-X5	Connection 2-pole	of item A2
X6	Connection 8-pole	of item A2
X7	Connection 4-pole	of item S1
X8	Connection 2-pole	
X9	Connection 2-pole	of item A2
X11	Connection 6-pole	of item A2
X12	Connection 1-pole	Diagnosis (K-wire)
Y1	Dosing Pump	

Wire Gauges	
	< 7.5 m
	7.5 - 15 m
	0.75 mm ²
	1.5 mm ²
	1.0 mm ²
	1.5 mm ²
	2.5 mm ²
	4.0 mm ²
	4.0 mm ²
	6.0 mm ²

Wire Colours	
bl	blue
br	brown
ge	yellow
gn	green
gr	grey
or	orange
rt	red
sw	black
vi	violet
ws	white

Fig. 714 Circuit Diagram Automatic Control Air Top 2000 Diagnosis, 24V ADR Operation with Control Element in Vehicles without Auxiliary Drive

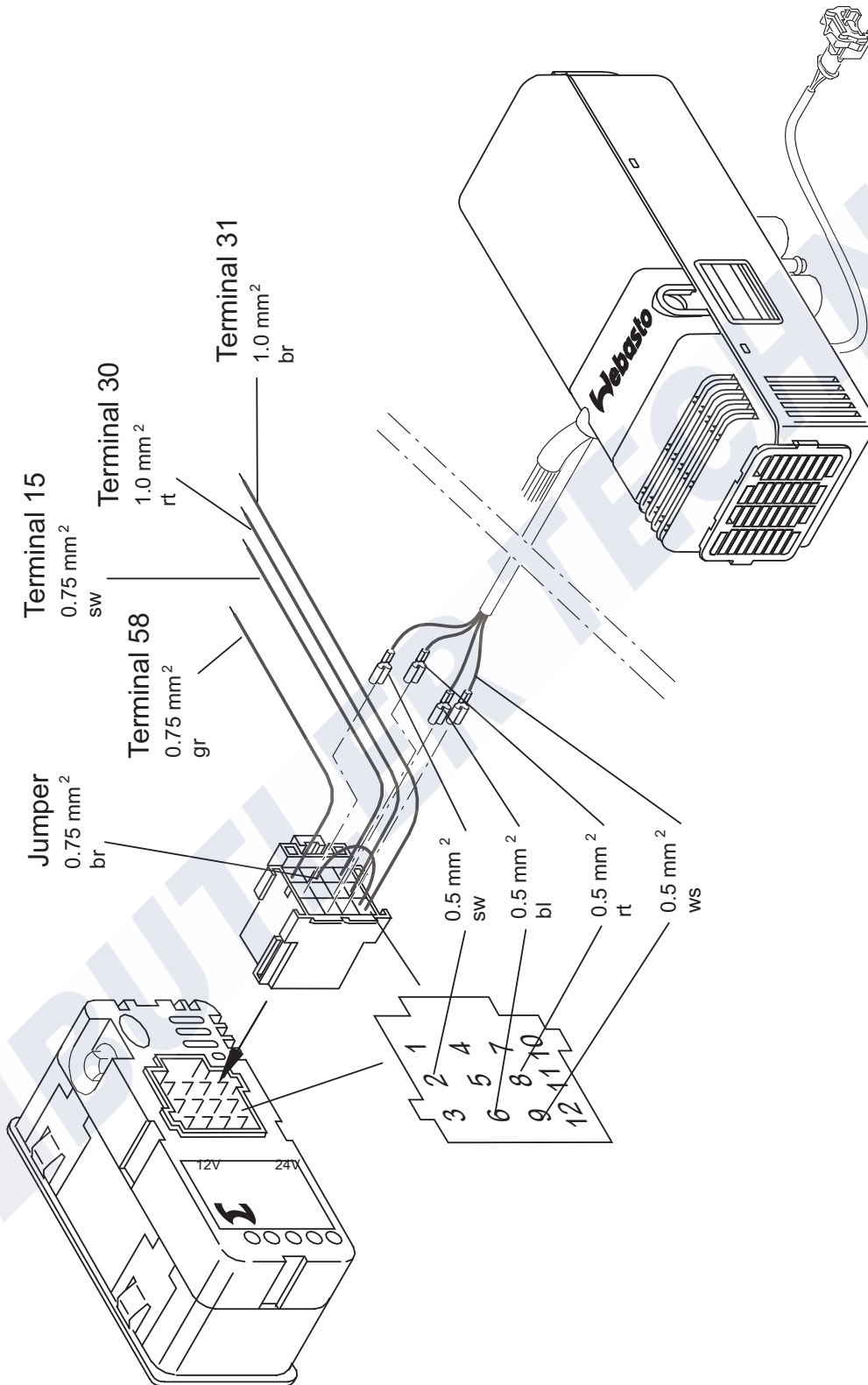

Fig. 715 Connection Diagram, Air Top 2000 Diagnosis with Combination Timer (not ADR!)

BUTLER TECHNIK

8 Servicing

8.1 General

This section describes the servicing procedures that may be performed with the air heater installed.

8.2 Work on the Air Heater

Prior to performing any work it is mandatory to disconnect the vehicle battery main lead. As long as the air heater is in operation or in run-down, the battery main supply must not be disconnected due to the danger of overheating resulting in a response of the overheat protection.

When performing extensive repairs on the heater a complete removal is advisable. When performing repairs requiring a relocation of the installation position, the relevant installation instructions and the vehicle-specific installation proposal have to be observed.

8.3 Work on the Vehicle

CAUTION

In the vicinity of the air heater a temperature of 85° C must not be exceeded under any circumstances (e.g. during body paint work).

8.4 Air Heater Test Run

WARNING

The air heater must not be operated, not even with timer, in enclosed areas like garages or workshops not equipped with an exhaust venting facility.

CAUTION

Operation of the heater without the control unit cover is not permitted and causes overheating.

8.5 Servicing

NOTE

In order to avoid the seizure of mechanical components, the air heater should be operated every 4 weeks for at least 10 minutes.

The air heater does not require maintenance. It should however be checked by Webasto-trained skilled personnel in regular intervals, the latest before the heating season begins (point of time, when the heater is more frequently in use due to weather conditions).

For reasons of the air heater's functional reliability perform the following servicing:

- check heating air inlet and outlet for foreign matter and contamination. (Contaminated or clogged heating air ducts may lead to overheating and thus response of the temperature limiter).
- Clean air heater exterior (prevent the ingress of water).
- Examine electrical connections for corrosion of contacts and for security.
- Check combustion air and exhaust ducts for damage and obstructions.
- Check fuel lines and fuel filter for leakage.
- Replace fuel filter if installed.

8.6 Visual Inspections and Installation Regulations

8.6.1 Heating Air System

CAUTION

The integration of the air heater into the vehicle's own air system is not permitted due to the system's high pressure.

The air heater can only be operated in the ventilation mode of operation.

Fitted in the air heater on the heating air intake side is a temperature sensor, which operates the heater in the relevant range of performance in conjunction with the control element dependent on the air intake temperature and position of the rated value transmitter. Heating performance is selected so that after quickly reaching the preselected indoor temperature it is maintained at this value. 12 Volt heaters (Air Top 2000 without Diagnosis) may be operated with an external temperature sensor (see 9.1.2). Air heaters Air Top 2000 Diagnosis 12 Volt and 24 Volt may also be operated with an external temperature sensor (see 9.1.2).

Minimum inside diameter of the heating air duct is 55 mm. Standard diameter is 60 mm.

NOTE

For heating air ducting only materials may be used which are temperature-proof to at least 130° C.

Maximum loss of pressure between suction and delivery side of the heating air duct 1.0 mbar (10 mm water column).

When exceeding this value the temperature limiter is very likely to respond. The heating air hose is to be secured at its joints.

The air heater, when used in the ventilation mode of operation, may also be employed for heating air ducting without any further accessories. A short circuit of the heating air flow is to be avoided.

8.6.2 Fuel Supply

Fuel is tapped from the fuel reservoir of the vehicle or from a separate fuel container. The rated pressure at the fuel tapping location is shown in Fig. 801.

Permissible fuel feed height H (m)	At max. permissible overpressure (bar) in fuel line
0.00	0.20
1.00	0.11
2.00	0.03
Permissible fuel suction height S (m)	At max. permissible low pressure (bar) in fuel tank
0.00	-0.10
0.50	-0.06
1.00	-0.02

8.6.2.1 Fuel Tapping

Vehicles with Diesel Engine

Fuel tapping must be from the fuel reservoir or from a separate tank (Figs. 802, 803 and 804). This separate fuel tapping avoids an influence on the pressure.

Vehicles with Carburettor Engine

Fuel tapping in motorcars may only be performed using the special Webasto fuel tap (e.g. Ident No. 470 910) possibly in the vicinity of the fuel tank. Connection to the supply or return line is optional, the return line must be routed almost to the tank floor, otherwise the return line may be extended.

The fuel tap is to be mounted so that air or gas bubbles can escape towards the fuel tank.

The fuel tap should be located in the engine compartment because the radiation of engine heat may cause gas bubbles to build up in the fuel lines causing malfunctions in the combustion operation.

Vehicles with Fuel Injection Engines

When installing the heater in vehicles with fuel injection system the fuel pump's location within or outside the fuel tank must be investigated first.

If the fuel pump is fitted inside the fuel tank, the fuel may be tapped only from the return line using the Webasto fuel tap only (e.g. Ident No. 470 910) ensuring that the return line is routed almost to the tank floor. If this is not the case, the Webasto fuel tap (see Fig. 802, 803 and 804) may be used.

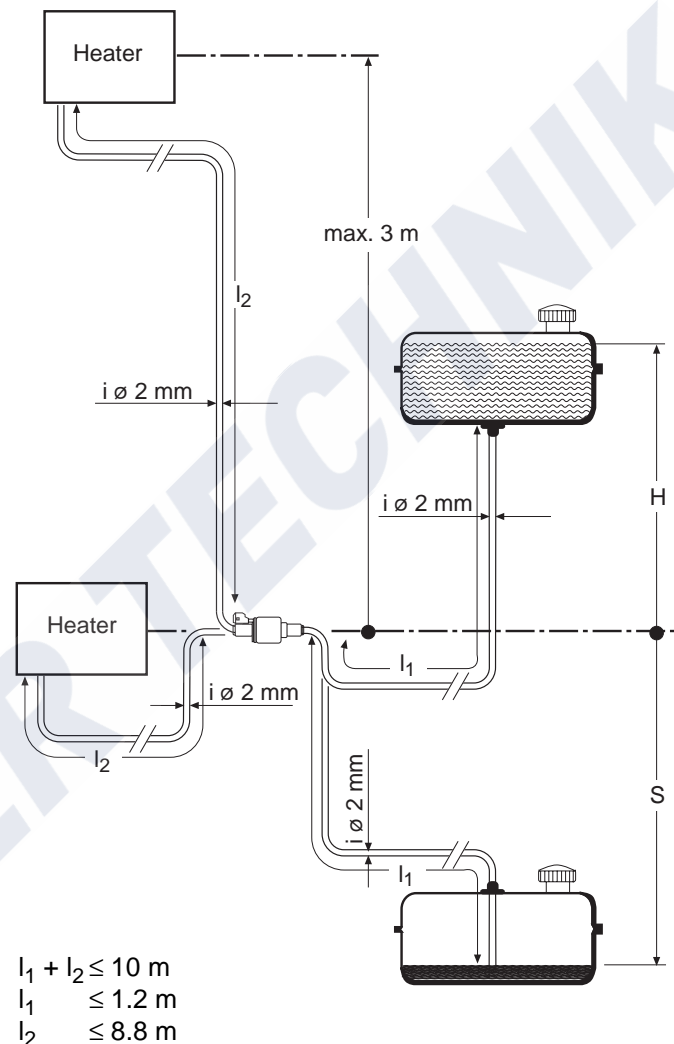

Fig. 801 Fuel Supply

In case of a fuel pump mounted externally to the tank the fuel tap between fuel tank and fuel pump may also only be fitted using the Webasto fuel tap (e.g. Ident No. 470 910).

Hole Pattern

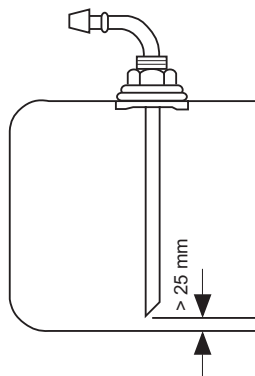
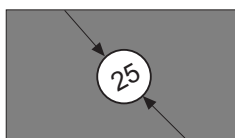

Fig. 802 Webasto Fuel Tank Tap*

* Use fuel tank tap only on metal fuel tanks

Fuel Tank Tap

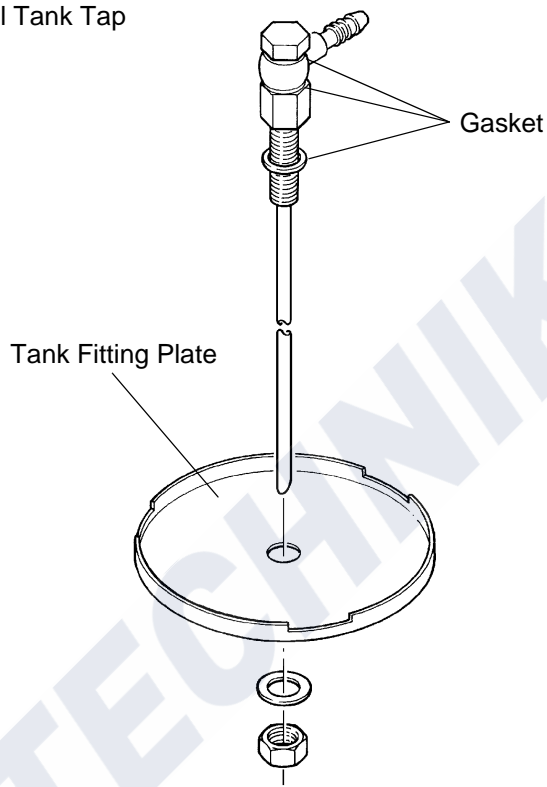
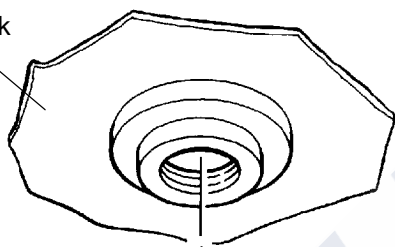

Fig. 804 Fuel Tapping from Plastic Tank (tapping via fitting plate)

Plastic Tank



Gasket

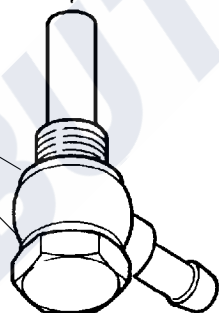

Fig. 803 Fuel Tapping from Plastic Tank (tapping via fuel drain plug)

NOTE

The fitting plate must be made of sheet metal!

8.6.2.2 Fuel Lines

Fuel lines may only be steel, copper, or plastic lines made of unhardened, light and temperature stabilised PA 11 or PA 12 (e.g. Mecanyl RWTL) according to DIN 73378. As in most cases a permanently rising fuel line routing cannot be ensured, the inner diameter must not exceed a certain value. Starting from an inside diameter of 4 mm, air or gas bubbles accumulate resulting in malfunctions should the lines be descending or have sags. The diameters specified in Fig. 801 ensure no disturbing formation of bubbles.

A descending line routing from the dosing pump to the heater should be avoided.

Loose fuel lines must be secured in order to avoid sagging. The installation must ensure protection against stone impacts and **undue temperatures** (exhaust line). The fuel line joints are to be secured against slipping with hose clamps.

Connection of 2 Pipes with Hose

The proper connection of fuel lines with hoses is shown in Fig. 805.

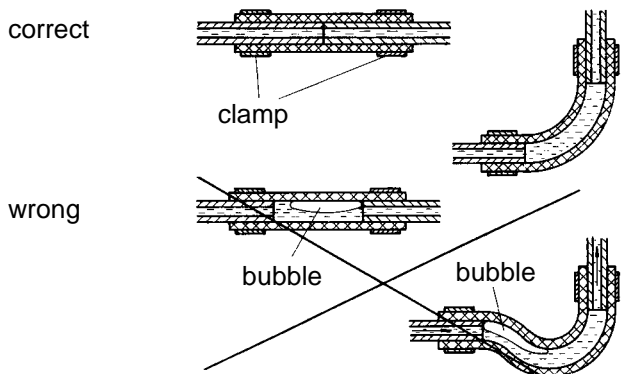
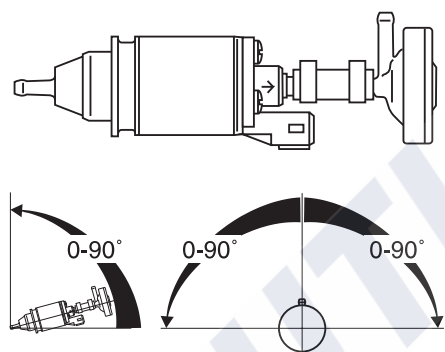

Fig. 805 Pipe/Hose Connection

8.6.3 Dosing Pump

The dosing pump is a combined delivery, dosing, and shut-off system and is subject to certain installation criteria (see Figs. 801 and 806).



12 Volt and 24 Volt - Fuel and Diesel DP 2

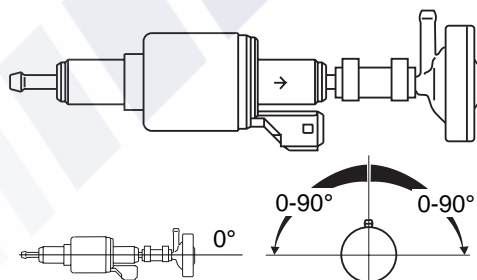

12 Volt and 24 Volt - Diesel DP 30
Installation Position only Horizontal

Fig. 806 Dosing Pump, Installation Position and Attachment

8.6.3.1 Installation Location

It is advantageous to mount the dosing pump in a cool location. The ambient temperature must never exceed +20° C during operation.

Dosing pump and fuel lines must not be installed in locations exposed to heat radiated by hot vehicle components. A heat shield is to be provided as required.

8.6.3.2 Installation and Attachment

The dosing pump is to be attached with anti-vibration mounts. The installation location is limited according to Fig. 806 to ensure sufficient self-venting capability. Due to the danger of corrosion the plug connection between dosing pump and dosing pump cable loom may only use Webasto original parts.

8.6.4 Fuel Filter

If there is the probability of contaminated fuel only the Webasto filter, Order No. 487 171, may be used. Installation possibly vertical up to horizontal at the most (observe direction of flow).

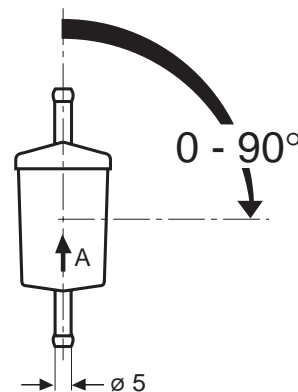

Fig. 807 Fuel Filter

8.6.5 Combustion Air Supply

Combustion air must under no circumstances be extracted from rooms with persons. The combustion air inlet must not point towards the forward direction of motion. It must be located so that no clogging by contamination is to be expected.

NOTE

For fuel operated heaters the combustion air tap must be located in a possibly cool and splash water proof position using a combustion air line.

If the air heater is located in a closed installation box, combustion air must be taken in from and the exhaust routed to the exterior. The feedthroughs must not allow exhaust fumes to enter the vehicle interior.

If a contaminated combustion air supply is expected, a combustion air filter can be fitted (Air Top 2000 D only).

8.6.6 Exhaust Line

Rigid pipes made of unalloyed or alloyed steel with a minimum wall thickness of 1.0 mm have to be used as exhaust line or flexible pipes made of alloyed steel only. The exhaust pipe is secured to the air heater e.g. with a clamp.

The exhaust muffler is preferably mounted near the air heater. The direction of flow is optional.

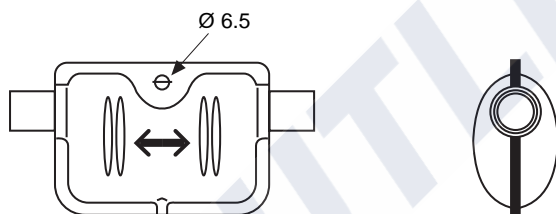

Fig. 808 Exhaust Muffler

Operation of the air heater is also permitted without muffler.

8.6.7 Combustion Air Intake and Exhaust Lines

In order to avoid damage to the dosing pump cable, no exhaust line may be used for the elongation of the combustion air intake line.

Length of the combustion air intake and exhaust line:

with muffler:	max. 2.0 m
without muffler:	max. 5.0 m

Both lines must be routed away from the heater in a descending attitude. If this is not possible, a condensate drain hole \varnothing 4 mm must be provided at the lowest point.

Inner diameter of lines:

Combustion air line:	22 mm
Exhaust line:	22 mm

NOTE

When exceeding an exhaust line length of 2 m, insulated exhaust lines have to be used (below minimum dew point).

Smallest bending radius: 50 mm

In order to ensure the angle of $90^\circ \pm 10^\circ$, an attachment is required not further than 150 mm away measured from the exhaust pipe end.

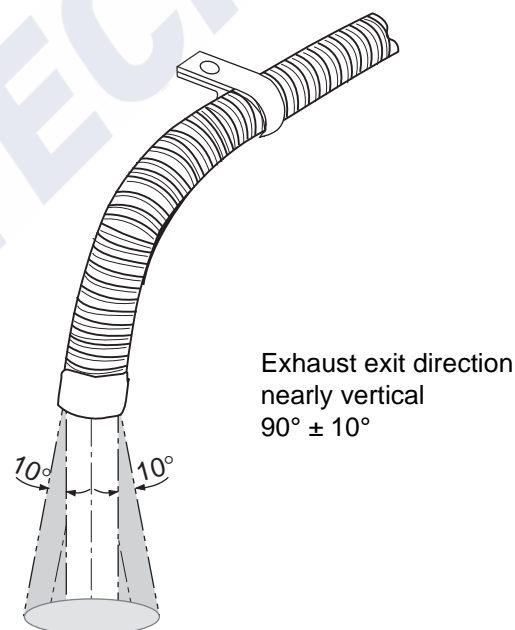

Exhaust exit direction
nearly vertical
 $90^\circ \pm 10^\circ$

Fig. 809 Exhaust Pipe Outlet, Installation Position

WARNING

Any exhaust exit direction other than the one shown in Fig. 809 may cause fires.

Sum of bends:

Combustion air line:	max. 270°
Exhaust line:	max. 270°

8.6.8 Electrical Connections

8.6.8.1 Connection Air Heater, Control Element

Electrical connection is according to Circuit Diagram Automatic Control (see Section 7).

For connection of the cable loom the cover (see 9.2.1.1) of the air heater has to be removed for connecting the cable loom plug(s) to the control unit. Avoid touching the control unit strip conductors.

Prior to first operation of the air heater the cover must be fitted to avoid the loss of heated air (air heater overheating).

The cable feedthrough may be from left or right.

8.6.8.2 Connection of Power Supply

Preferably from the vehicle's central electrics. For protection of the air heater an additional flat fuse holder is to be fitted (deliverable item). The fuse holder may only be located in the vehicle interior.

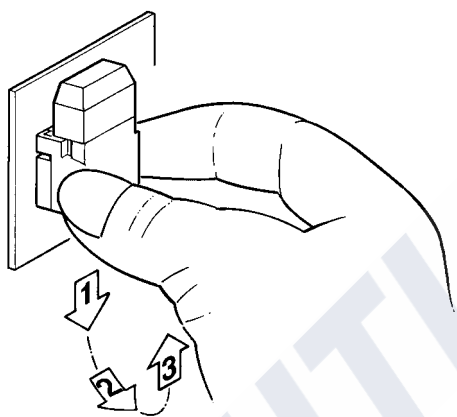

Fig. 810 Removal of Fuse Holder Attachment Plate

F = 10A 24V
15A 12V

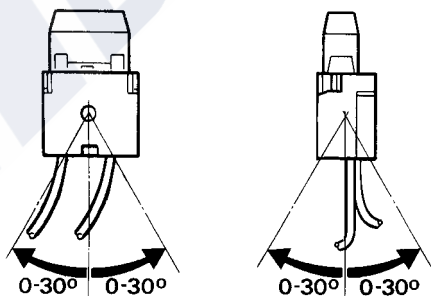

Fig. 811 Fuse Holder, Installation Position

8.6.8.3 Connection Control Element

The cable loom is prefabricated to connect to the control element (rated value transmitter).

For plug disconnection pull on terminal plug only (Fig. 813).

By pulling on the cable loom the terminal plug is arrested (self-locking).

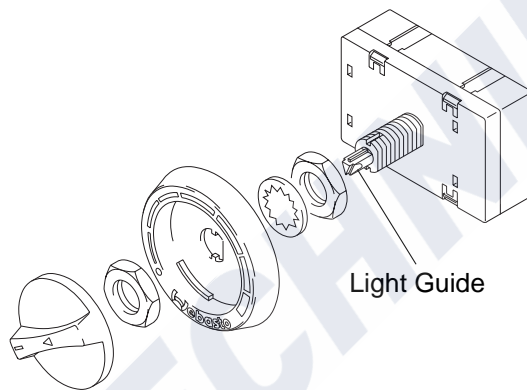

Fig. 812 Control Element

NOTE

The light guide must be in contact with the rotating knob.

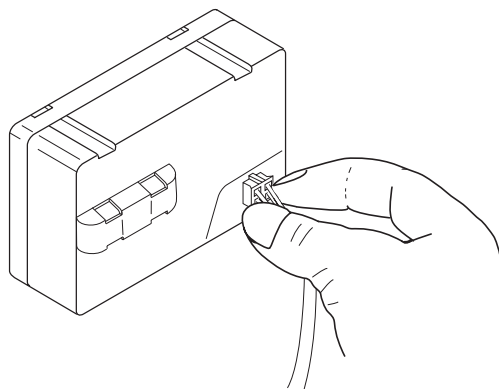
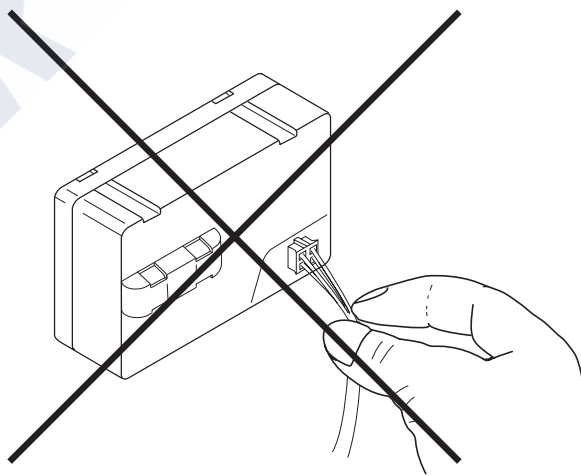
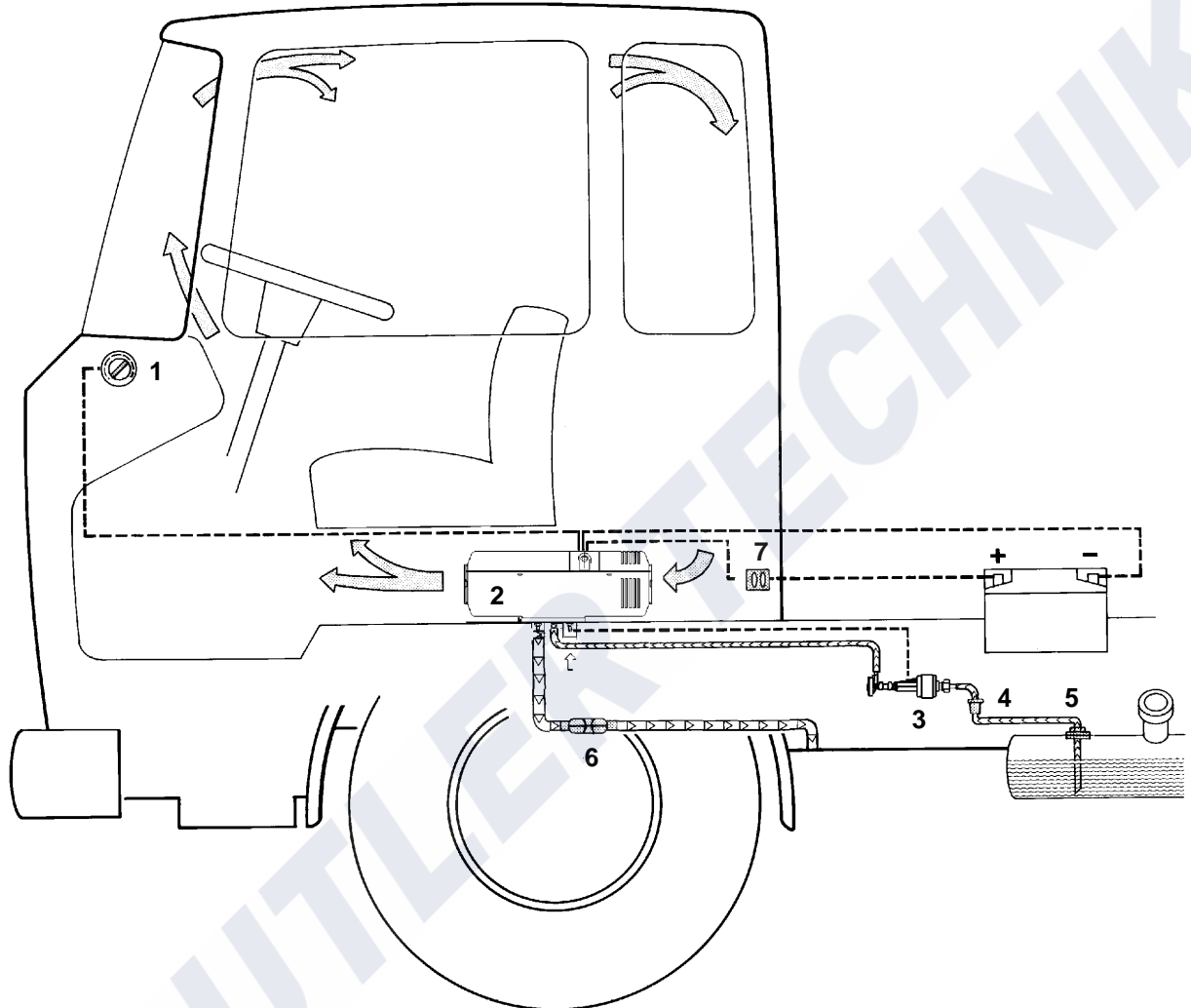

Fig. 813 Pulling the Plug



- 1 Control Element
- 2 Air Heater
- 3 Dosing Pump and Anti-Vibration Mount
- 4 Fuel Filter (Accessory)
- 5 Fuel Tap
- 6 Exhaust Muffler
- 7 Fuse

Fig. 814 Example of an Installation

8.7 Removal and Installation

CAUTION

In installed condition only the following removal and disassembly procedures are allowed, the upper housing shell being accessible for removal:

- Replacement of control unit
- Replacement of temperature limiter

8.7.1 Air Heater, Removal and Installation

8.7.1.1 Removal

1. Disconnect battery terminal leads.
2. Withdraw cover from upper housing shell according to 9.2.1.1.
3. Disconnect plug of cable loom from control unit.
4. Disconnect cable to dosing pump at cable disconnect.
5. Disconnect fuel inlet on air heater.
6. Disconnect connections of combustion air intake and exhaust outlet on air heater.
7. Remove four nuts and lock washers on air heater.
8. Remove air heater and discard gasket.

8.7.1.2 Installation

1. Locate air heater with new gasket in installation position and secure with four nuts and lock washers (use original Webasto nuts only).
2. Tighten nuts with $6 + 1$ Nm.
3. Secure connection for fuel inlet on air heater.
4. Secure connections for combustion air inlet and exhaust outlet on air heater.
5. Connect dosing pump cable to dosing pump wiring harness.
6. Connect plug of cable loom to control unit.
7. Plug on cover and arrest.
8. Reconnect battery terminal leads.
9. Bleed fuel supply system.

8.7.2 Replacement of Control Unit

8.7.2.1 Removal

NOTE

During removal avoid the build-up of static charge (i.e. do not touch strip conductors).

1. Withdraw cover from upper housing shell according to 9.2.1.1.
2. Disconnect plug of cable loom from control unit.
3. Withdraw covers for heating air inlet and outlet (5 and 3) according to 9.2.1.2.
4. Remove upper shell according to 9.2.3.1.
5. Disconnect plugged connections (1, Fig. 815 or Fig. 816) of terminal.
6. Remove screws (3) and remove control unit (2).

8.7.2.2 Installation

CAUTION

When installing a new control unit in heaters Air Top 2000 without diagnosis, it is mandatory to observe the remarks in 8.8.

NOTE

During installation avoid the build-up of static charge (i.e. do not touch strip conductors).

1. Locate control unit (2, Fig. 815) in installation position and secure with screws (3). Ensure control unit engages in arrester groove (6). Torque screws to 0.7 ± 0.07 Nm.
2. Connect plug connections to terminal (Fig. 701 or Fig. 702).
3. Plug on upper housing shell and fix in position.
4. Slide on covers for heating air inlet and outlet and fix in position.
5. Connect plug of cable loom to control unit.
6. Fit cover and fix in position.

8.7.3 Replacement of Temperature Limiter

8.7.3.1 Removal

1. Withdraw cover from upper housing shell according to 9.2.1.1.
2. Disconnect plug of cable loom from control unit.
3. Withdraw covers for heating air inlet and outlet according to 9.2.1.2.
4. Remove upper housing shell according to 9.2.1.3.
5. Disconnect plugged connection (blue) from terminal.
6. Remove lock washers or Ejoyt DG screws (4, Fig. 815 or Fig. 816).
7. Remove temperature limiter (5).

8.7.3.2 Installation

1. Locate temperature limiter (5, Fig. 815 or Fig. 816) in installation position and secure with lock washers or Ejoyt DG screws (4). Ensure that temperature limiter rests properly on heat exchanger.
2. Torque Ejoyt DG screws to 1.5 ± 0.15 Nm.
3. Connect plug connections (blue) to terminal.
4. Plug on upper housing shell and fix in position.
5. Slide on covers for heating air inlet and outlet and fix in position.
6. Connect plug of cable loom to control unit.
7. Fit cover and fix in position.

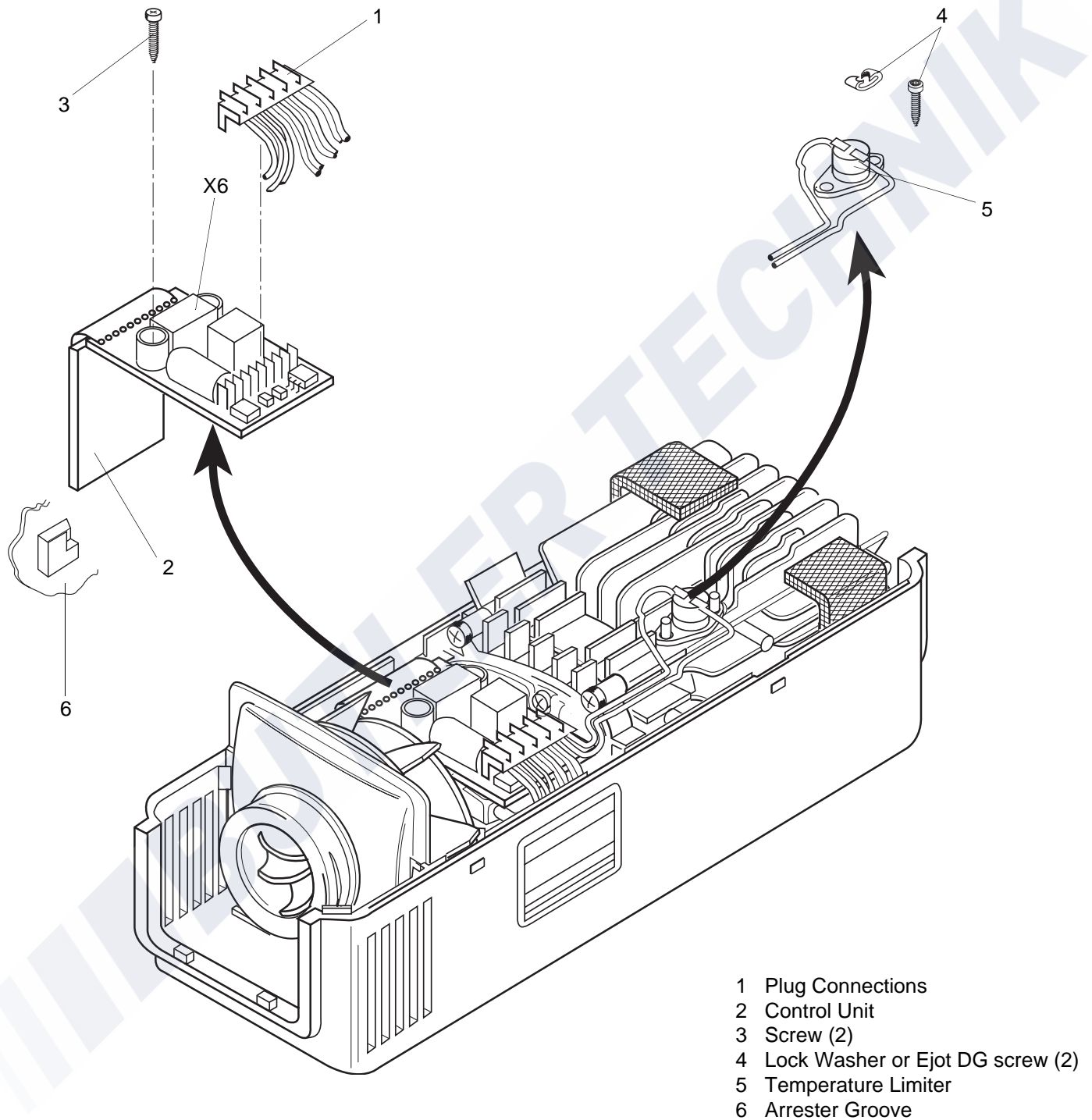

Fig. 815 Replacement of Control Unit and Temperature Limiter (Air Top 2000 without Diagnosis)

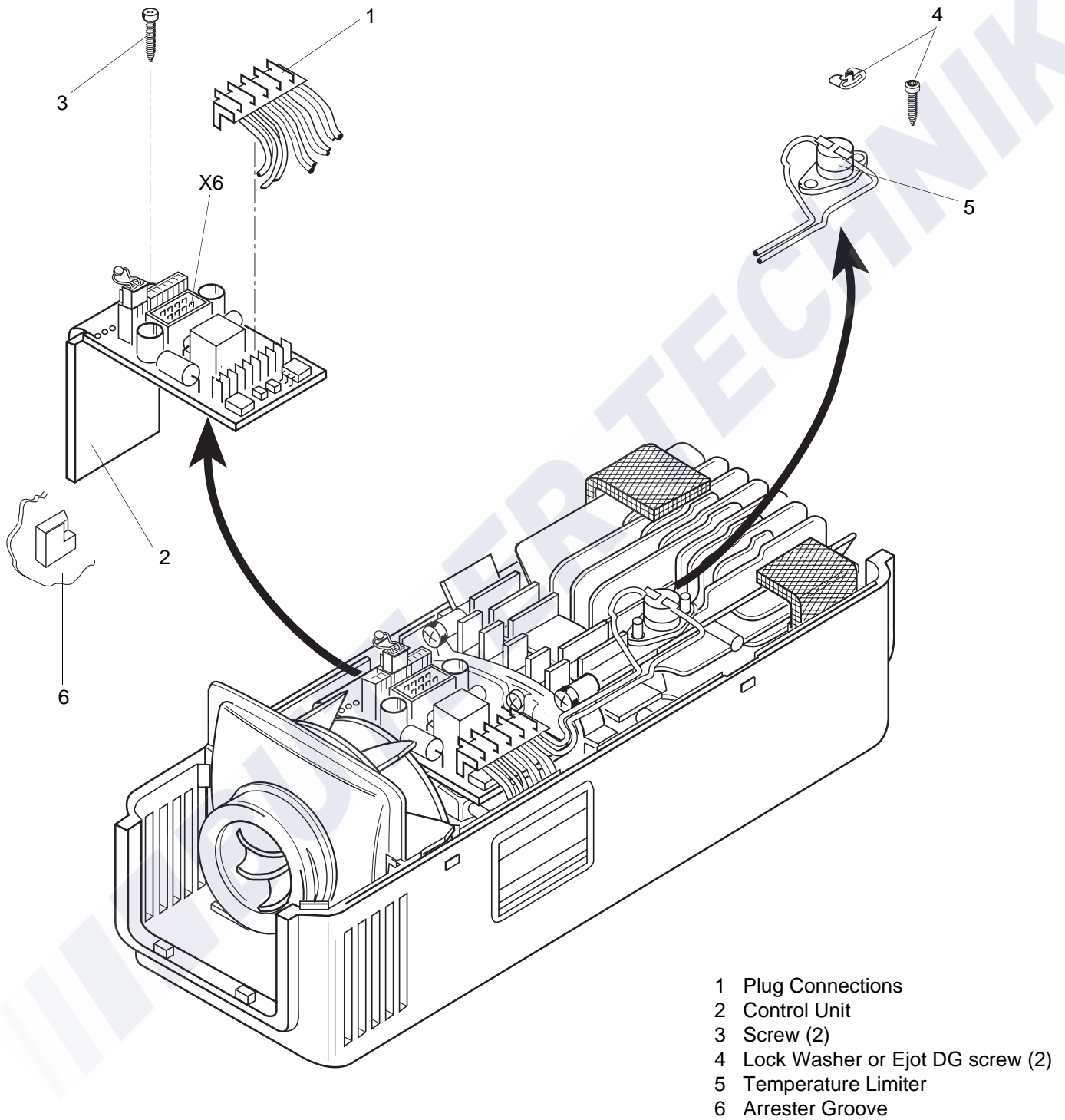

Fig. 816 Replacement of Control Unit and Temperature Limiter (Air Top 2000 Diagnosis)

8.8 Installation of new Control Units

CAUTION

When replacing the control unit the following must be observed:

- When replacing the control unit Air Top 2000 (12 Volt) without external temperature sensor with a new control unit Air Top 2000 Diagnosis (12 Volt) without external temperature sensor no further instructions for replacement as detailed in 8.7.2 are applicable.
- When replacing the control unit Air Top 2000 (12 Volt) with external temperature sensor with the control unit Air Top 2000 Diagnosis (12 Volt) with external temperature sensor the modifications per 8.8.1 must be performed.

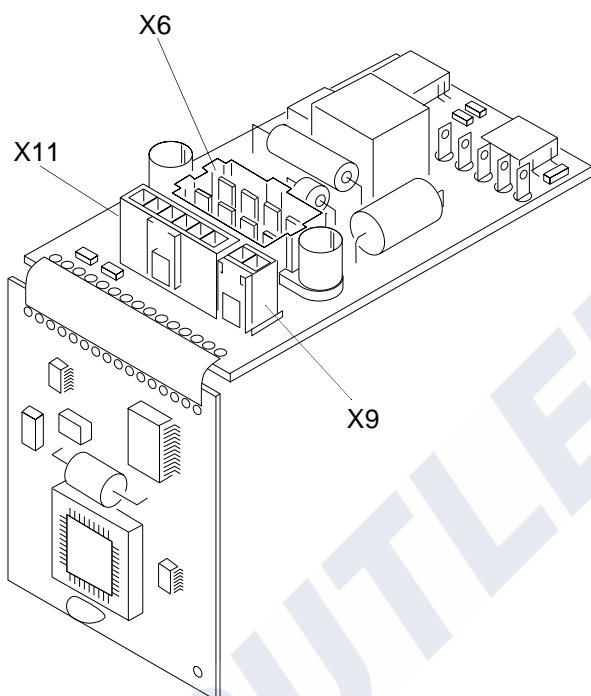

Control Unit Air Top 2000 Diagnosis

NOTE

If a new temperature sensor is to be used place an order for no. 883 84A (including new cover).

- When replacing the control unit Air Top 2000 (24 Volt) not ADR with a control unit Air Top 2000 Diagnosis (24 Volt) not ADR the modifications per 8.8.2 must be incorporated.

CAUTION

Not performing the modification may result in a short circuit.

- When replacing the control unit Air Top 2000 ADR (24 Volt) with a control unit Air Top 2000 Diagnosis ADR (24 Volt) perform modifications per 8.8.3.

WARNING

Failure to perform modifications will result in a potential safety risk.

In all cases there will be no possibility for diagnosis after replacement as the wiring harness installed in the vehicle is not provided with a diagnosis connector.

8.8.1 Replacement of Control Unit Air Top 2000 (12 Volt) with External Temperature Sensor

- Remove control unit according to 8.7.2.1.
- Remove leaf spring contacts 4 and 6 from connector X6.

NOTE

The following step is not applicable when installing a new temperature sensor.

- Position leaf spring contacts order no. 880 38A (must be ordered) and arrest in connector X9 order no. 881 97A (must also be ordered). Polarity is irrelevant.
- Install new control unit according to 8.7.2.2.
- Connect connectors X6 and X9.

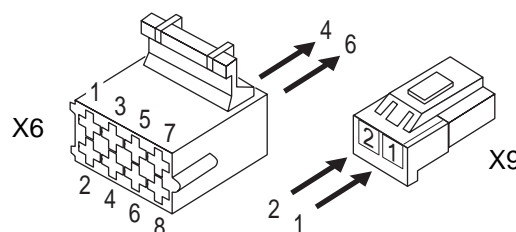

8.8.2 Replacement of Control Unit Air Top 2000 (24 Volt) not ADR

- Remove control unit according to 8.7.2.1.
- Remove leaf spring contacts of grey and violet wire from connector X6, contacts 4 and 6.
- Install new control unit according to 8.7.2.2.
- Connect connector X6.

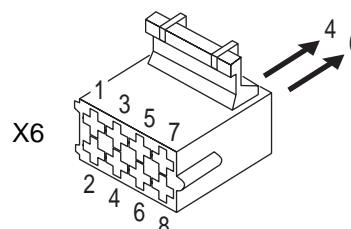

8.8.3 Replacement of Control Unit Air Top 2000 (24 Volt) ADR

1. Remove control unit according to 8.7.2.1.
2. Remove leaf spring contacts of grey and violet wire from connector X6, contacts 4 and 6.
3. Arrest leaf spring contacts in connector X11 as follows: grey wire in contact 3, violet wire in contact 2.
4. Install new control unit according to 8.7.2.2.
5. Connect connector X6 and X11.
6. Perform functional check. Test ADR switch-off as required stopping engine and starting auxiliary drive.

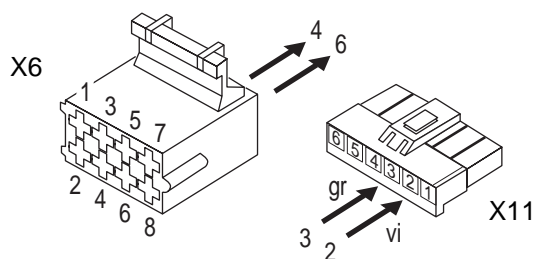

8.9 First Operation

After installation of the air heater the fuel supply system must be bled thoroughly.

NOTE

Due to low fuel consumption several switch-ons are required to prime the fuel supply line to the air heater.

During the test run of the air heater all connections are to be checked for no leakage and tight fit. Should the air heater during operation assume an error lockout condition, perform troubleshooting.

9 Repair

9.1 General

This section describes the repairs that may be performed on the air heater Air Top 2000 and Air Top 2000 Diagnosis serial no. 30.000 and up when removed. Any further disassembly will void the warranty. For reassembly only components of the proper spare kits are to be used.

9.1.1 Work on Components after Disassembly

CAUTION

All gaskets located between disassembled components as well as the exhaust outlet seal must always be replaced and discarded.

9.1.1.1 Cleaning

- All components disassembled must be cleaned with cleaning spirit and subsequently dried with pressurized air.
- All sealing compound must be carefully removed from components using a suitable tool.

9.1.1.2 Visual Inspection

- Examine all components for damages (cracks, deformation, wear, etc.) and replace as necessary.
- Examine connectors and wiring for corrosion, loose contacts, wrong crimping, etc. and repair as necessary.
- Check terminals for corrosion and contacts for security. Repair as required.

9.1.2 Incorporation of Modifications

NOTE

The continuous design improvement of the heaters is intended to optimise their serviceability avoiding failures or malfunctions.

In general equipment in service may be retrofitted with available modification kits.

In the following those modifications which may be incorporated easily during maintenance:

- installation of an external temperature sensor for optimising temperature control Air Top 2000 Diagnosis (see 9.1.2.1).
- installation of an external temperature sensor for optimising temperature (see 9.1.2.2) (only for 12 Volt heaters Air Top 2000 without Diagnosis).

9.1.2.1 Installation of an External Temperature Sensor (Air Top 2000 Diagnosis)

General

The heater Air Top 2000 controls the desired temperature best when its temperature sensor is exposed to the air temperature of the most probable surrounding in use. This might not always be possible due to the installation conditions with the temperature sensor being integrated in the heater. In such case the best temperature control may be achieved by installation of an external temperature sensor in the relevant room area.

Procedure

1. Select adequate installation location for external temperature sensor.

NOTE

- Temperature sensor should not directly be exposed to heated air flow or located in the vicinity of heating sources (e.g. vehicle own heater).
 - For installation of the sensor in the motorcar we recommend to locate the sensor in mid height in possibly vertical location.
 - The installation location should not be exposed to direct sun light.
 - Do not mount temperature sensor behind curtains or similar.
2. Mount external temperature sensor and route cable to control unit.
 3. Remove temperature sensor with connector.
 4. Connect connector X9 and place cover.
 5. Perform test run and check control behaviour.

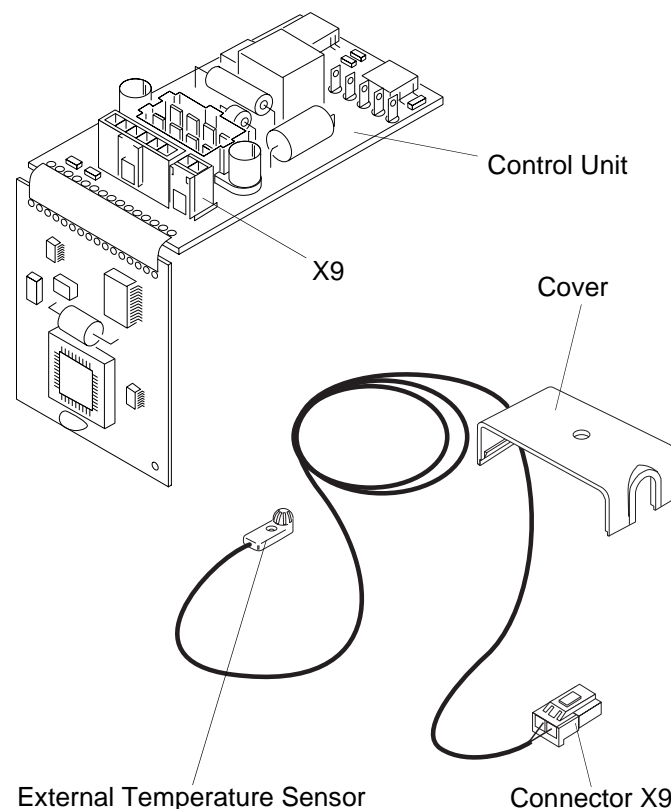

9.1.2.2 Removal of External Temperature Sensor (Air Top 2000 without Diagnosis)

General

The heater Air Top 2000 controls the desired temperature the best when its temperature sensor is exposed to the air temperature of the most probable surrounding in use. This might not always be possible due to the installation conditions with the temperature sensor being integrated in the heater. In such case the best temperature control may be achieved by installation of an external temperature sensor (Order No. 850 49A) in the relevant living area.

Procedure

1. Remove control unit (see 8.7.2.1).
2. Using a suitable tool (e.g. cutting pliers or similar) remove temperature sensor from control unit.

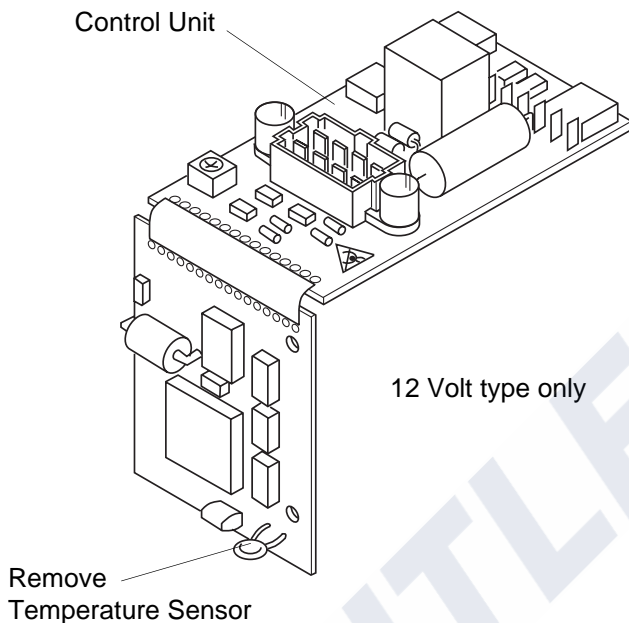

3. Select adequate installation location for external temperature sensor.

NOTE

- Temperature sensor should not directly be exposed to heated air flow.
 - For installation of the sensor in the motorcar we recommend to locate the sensor on the window spar of the windshield or in the vicinity of the air intake in the air flow for air circulation operation.
 - For installation of the sensor in the lorry we recommend to locate the sensor on the window spar of the windshield or on the underside of the roof console.
4. Mount external temperature sensor and route cable to heater.
 5. Install control unit (see 8.7.2.2).
 6. Arrest leaf spring contacts in empty compartments of connector X6 (contacts 4 and 6). Polarity is irrelevant.

7. Connect connector X6 and fit cover.
8. Perform test run and check control behaviour.

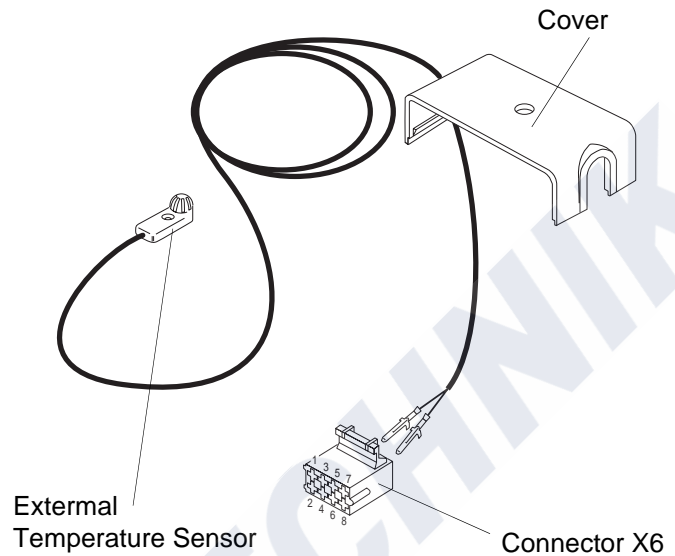

9.2 Disassembly and Assembly

9.2.1 Removal of Housing Components/Covers

9.2.1.1 Cover for Electrical Connection

Dependent on the type of installation the cable loom exits the air heater either on the left or right. The cover may be levered off using a blunt blade in the areas marked (X).

9.2.1.2 Covers for Heating Air Inlet and Outlet

Both covers (3 and 5, Fig. 901) may be removed by a slight side lift and a slide to left or right out of the locked position.

9.2.1.3 Upper Housing Shell

NOTE

The covers for the heating air inlet and outlet must be removed.

By simultaneously exerting pressure on the catches of the upper housing shell (2, Fig. 901) in the areas (Y), the shell disengages and can be lifted off.

9.2.1.4 Lower Housing Shell

By simultaneously exerting a light pull to the lower housing shell (4, Fig. 901) in the areas (Z), the catch is released and the shell may be separated from the motor housing.

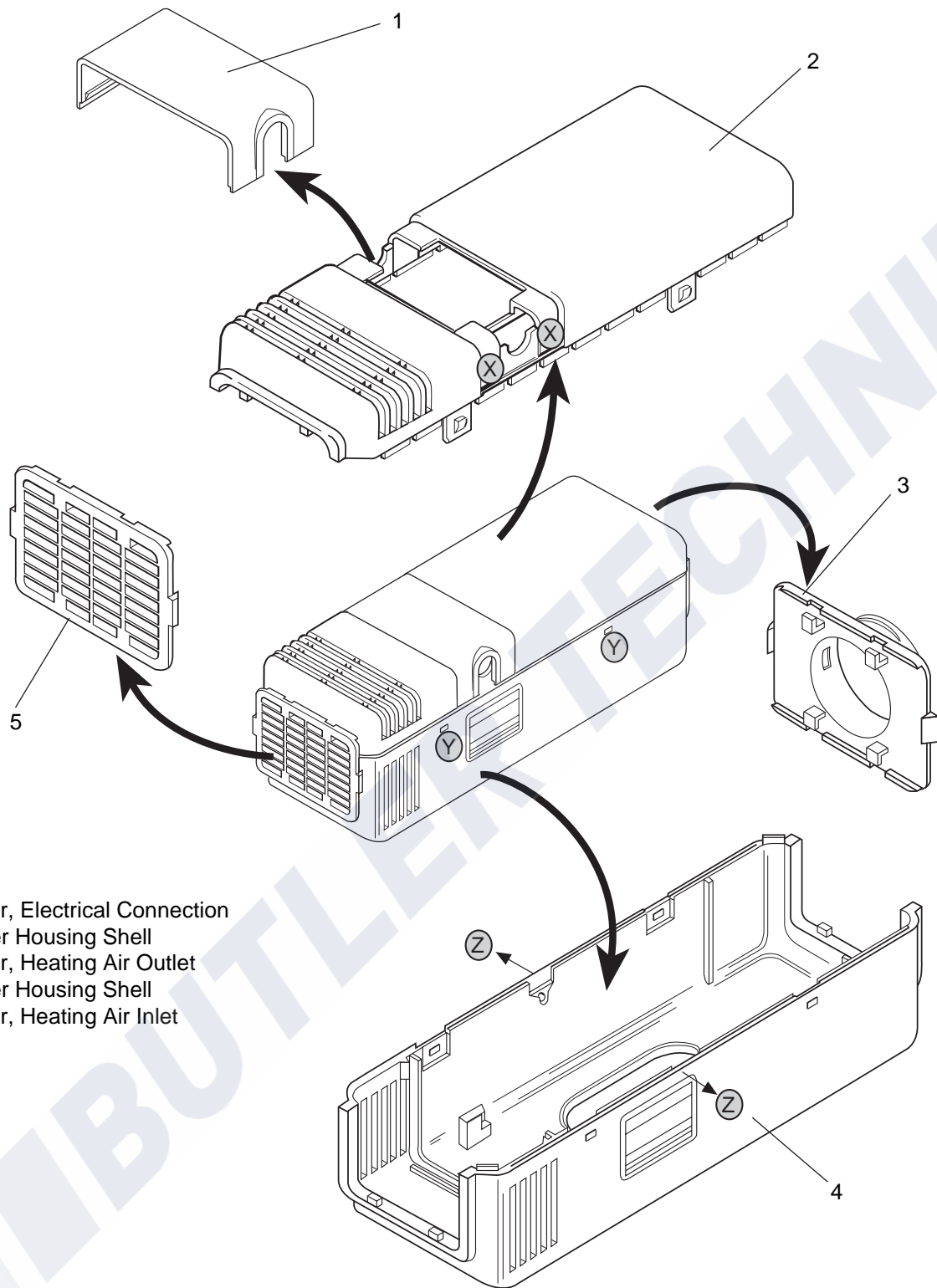

- 1 Cover, Electrical Connection
- 2 Upper Housing Shell
- 3 Cover, Heating Air Outlet
- 4 Lower Housing Shell
- 5 Cover, Heating Air Inlet

Fig. 901 Removal of Housing Components/Covers

9.2.2 Replacement of Control Unit

NOTE

The procedure for replacement of the control unit is identical for the air heater in installed or removed condition.

Replacement is to be performed in accordance with 8.7.2.

9.2.3 Replacement of Temperature Limiter

NOTE

The procedure for replacement of the temperature limiter is identical for the air heater in installed or removed condition.

Replacement is to be performed in accordance with 8.7.3.

NOTE

Air heater Air Top 2000 without Diagnosis shown. Figure is also applicable for replacement of combustion air fan or Air Top 2000 Diagnosis.

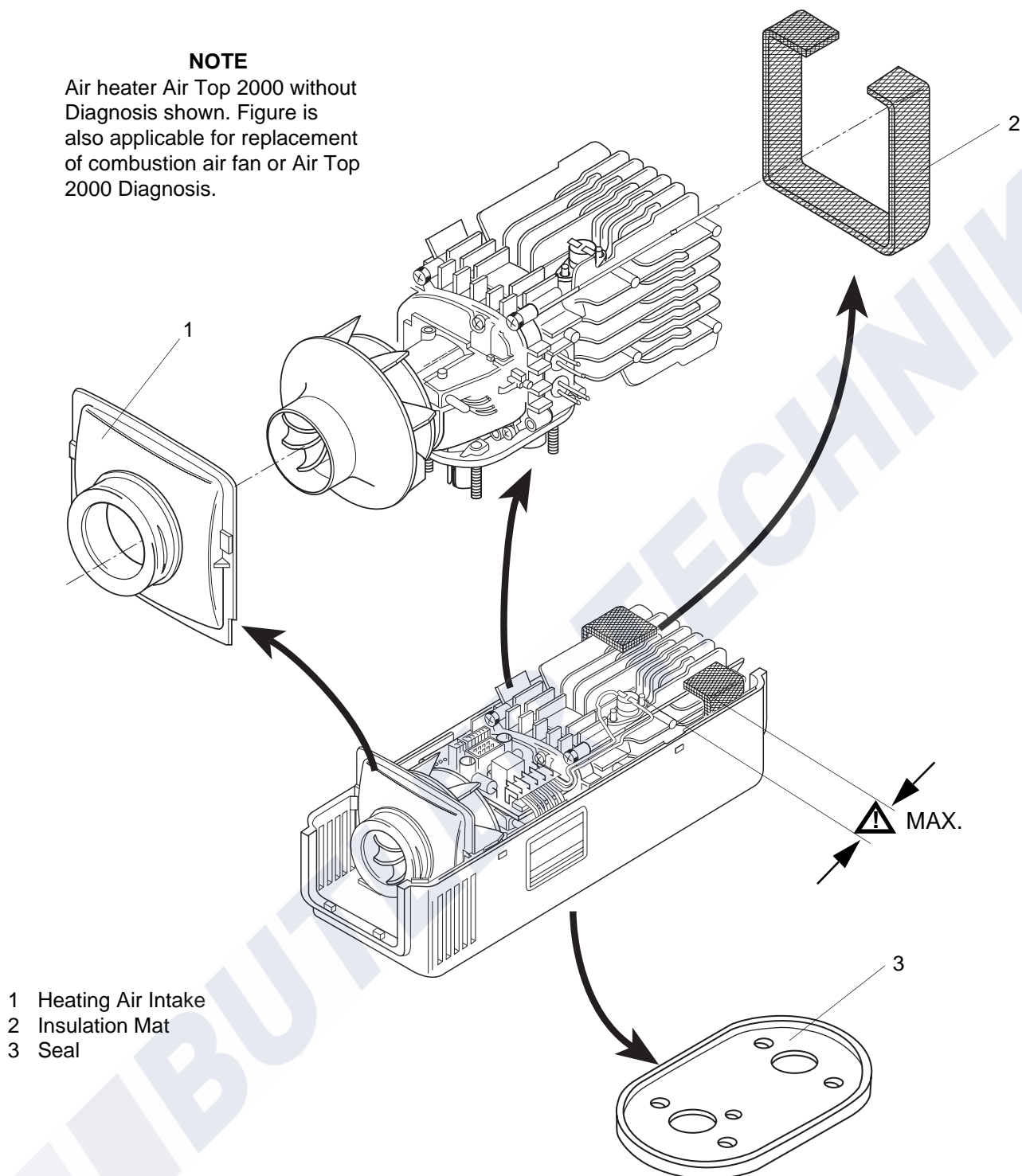

- 1 Heating Air Intake
- 2 Insulation Mat
- 3 Seal

Fig. 902 Replacement of Combustion Air Fan (Removal)

9.2.4 Replacement of Combustion Air Fan

9.2.4.1 Removal

1. Remove air heater (see 8.7.1.1).
2. Remove control unit (see 8.7.2.1).
3. Remove seal (3, Fig. 902) from lower housing shell and discard.
4. Remove air heater from lower housing shell.
5. Remove heating air intake (1, Fig. 902) and remove insulation mat (2).
6. Remove screws (1, Fig. 903).
7. Withdraw combustion air fan (3) and remove gasket (2).
8. Perform work on components after disassembly (see 9.1.1).

9.2.4.2 Installation

1. Ensure that sealing surfaces on combustion air fan and on heat exchanger are not damaged.
2. Place new gasket (2, Fig. 903) onto flange of combustion air fan (3).

CAUTION

The combustion air fan may be fastened with self-cutting Ejot DG screws or on older heater models with sheet metal screws. During assembly observe the different hole diameters and torque values.

NOTE

Apply Loctite to sheet metal screws (1).

3. Bring combustion air fan (3) into assembly position and mount using screws (1).
4. Torque sheet metal screws to 4 ± 0.4 Nm; Ejot DG screws to 6 ± 0.6 Nm.

CAUTION

In order to ensure proper operation of the heater and temperature limiter observe the following when installing the insulation mat:

- Position insulation mat according to Fig. 903 so that the maximum distance to the temperature limiter is obtained.
- Loose wires of the wired screen of the insulation mat must not come into contact with the temperature limiter and must be cut off.
- When mounting the upper housing shell make sure that the insulation mat is fixed in position. Old insulation mats or mats already heavily flattened must be replaced.

5. Place air heater with heating air intake (1, Fig. 902) and insulation mat (2) into lower housing shell and on side lock in position in housing.
6. Fit new seal (3) to lower housing shell.
7. Install control unit (see 8.7.2.2).
8. Install air heater (see 8.7.1.2).
9. Check CO₂ setting and adjust as required (see 6.2).

- 1 Sheet Metal Screw or Ejot DG screw (5)
- 2 Gasket
- 3 Combustion Air Fan

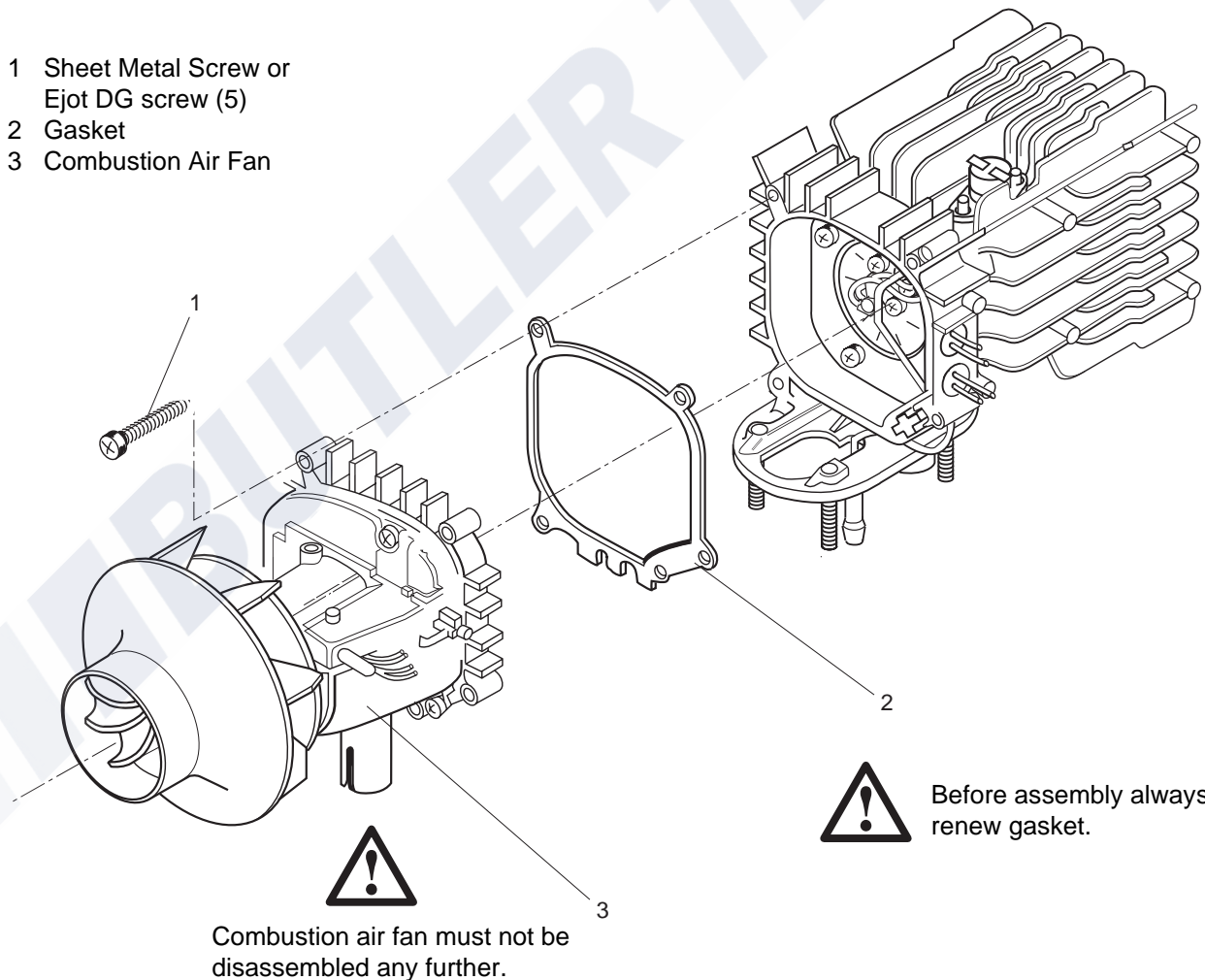

Fig. 903 Replacement of Combustion Air Fan (Disassembly)

9.2.5 Replacement of Flame Sensor

9.2.5.1 Removal

1. Remove air heater (see 8.7.1.1).
2. Remove control unit (see 8.7.2.1).
3. Remove combustion air fan (see 9.2.4.1).
4. Remove 2 screws (3, Fig. 904) and spoiler (2) for cable protection.
5. Push out cable grommet (10) towards inside.
6. Carefully bend up locking tab (4) and withdraw flame sensor (1) from burner insert (5).
7. Remove flame sensor.
8. Perform work on components after disassembly (see 9.1.1).

9.2.5.2 Installation

NOTE

Burner insert may be fastened with self-cutting Eject DG screws or with sheet metal screws (3, Fig. 904).

CAUTION

Route cable of flame sensor below fuel pipe.

1. Pass flame sensor (1) below fuel pipe, feed connector through opening and push in cable grommet (10).
2. Feed cable with protection sleeve through locking tab and insert flame sensor (1) into burner insert (5).
3. Squeeze locking tab (4).
4. Secure burner insert (5) with four screws (3) and fit spoiler (2) for cable protection.
5. Pull cable of flame sensor tight.
6. Torque all 4 screws (3) to 4 ± 0.4 Nm.
7. Mount combustion air fan (see 9.2.4.2).
8. Install control unit (see 8.7.2.2).
9. Install air heater (see 8.7.1.2).

9.2.6 Replacement of Glow Plug

9.2.6.1 Removal

1. Remove air heater (see 8.7.1.1).
2. Remove control unit (see 8.7.2.1).
3. Remove combustion air fan (see 9.2.4.1).
4. Push out cable grommets (9 and 10, Fig. 904) towards inside.
5. Remove four screws (3) and spoiler (2).
6. Tilt and withdraw burner insert (5) carefully.

NOTE

Ensure that burner insert (5) has separated from burner tube (6).

CAUTION

The glow plug has to be pulled out with utmost care and must under no circumstances be twisted (danger of breaking). After a long period of combustion operation the glow plug may be caked by fuel deposits. In this case allow creep oil to react long enough to free glow plug for withdrawal.

7. Loosen screw (13) and withdraw and remove glow plug (11) from burner insert.
8. Perform work on components after disassembly (see 9.1.1).

9.2.6.2 Installation

NOTE

The burner insert may be fastened with self-cutting Eject DG screws or on older heater models with sheet metal screws (3, Fig. 904).

1. Insert new gasket (7, Fig. 904) into heat exchanger and bring combustion tube (6) in assembly position.
2. Ensure that starting air bore is not clogged. If required clean with wire (approx. 1 mm \varnothing on previous burners, for new burners approx. 4 mm \varnothing) (see Detail A).

CAUTION

During glow plug installation on previous burners observe twist lock (see Detail B). That means that the glow plug has to be inserted so that the contacts point towards the heat exchanger. Otherwise there will be the danger of a short circuit.

3. Feed glow plug (11) into burner insert (5) and arrange cable protective sleeve in slot of burner insert.

CAUTION

When performing the following step ensure that glow plug is inserted in burner insert fully against stop.

4. Secure glow plug (11) with screw (13). Torque screw (13) with 0.8 Nm.
5. Locate burner insert (5) in heat exchanger (8) observing that cable of flame sensor is positioned below fuel pipe.
6. Feed connectors of glow plug and flame sensor through openings and push in cable grommets (9 and 10).

CAUTION

When performing the following step ensure that there is a tight fit between grommet (12) and heat exchanger (8).

7. Secure burner insert (5) using screws (3) and attach spoiler (2). Torque screws (3) to 4 ± 0.4 Nm.
8. Mount combustion air fan (see 9.2.4.2).
9. Install control unit (see 8.7.2.2).
10. Install air heater (see 8.7.1.2).

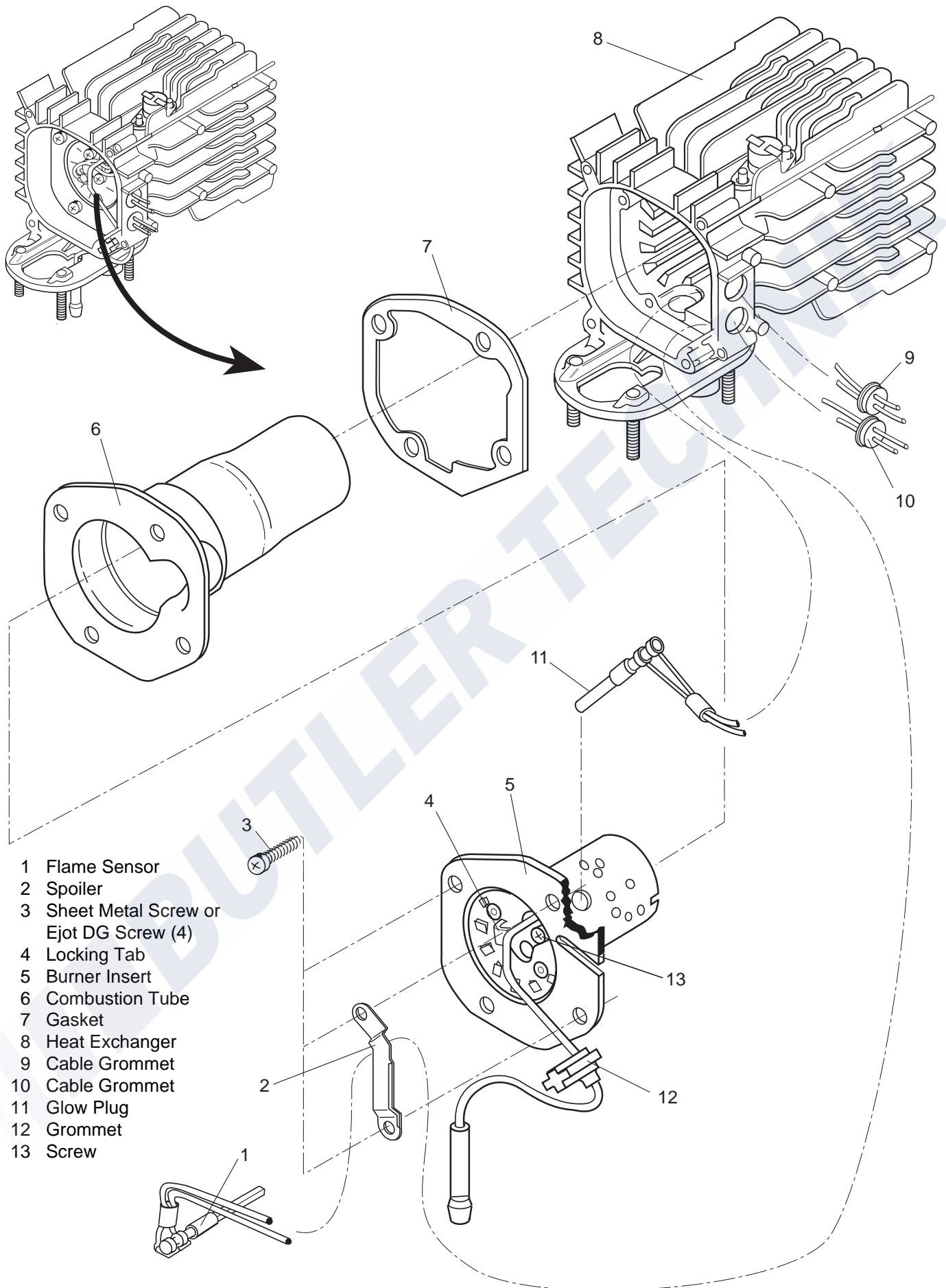

Fig. 904 Disassembly of Heat Exchanger (Sheet 1 of 2)

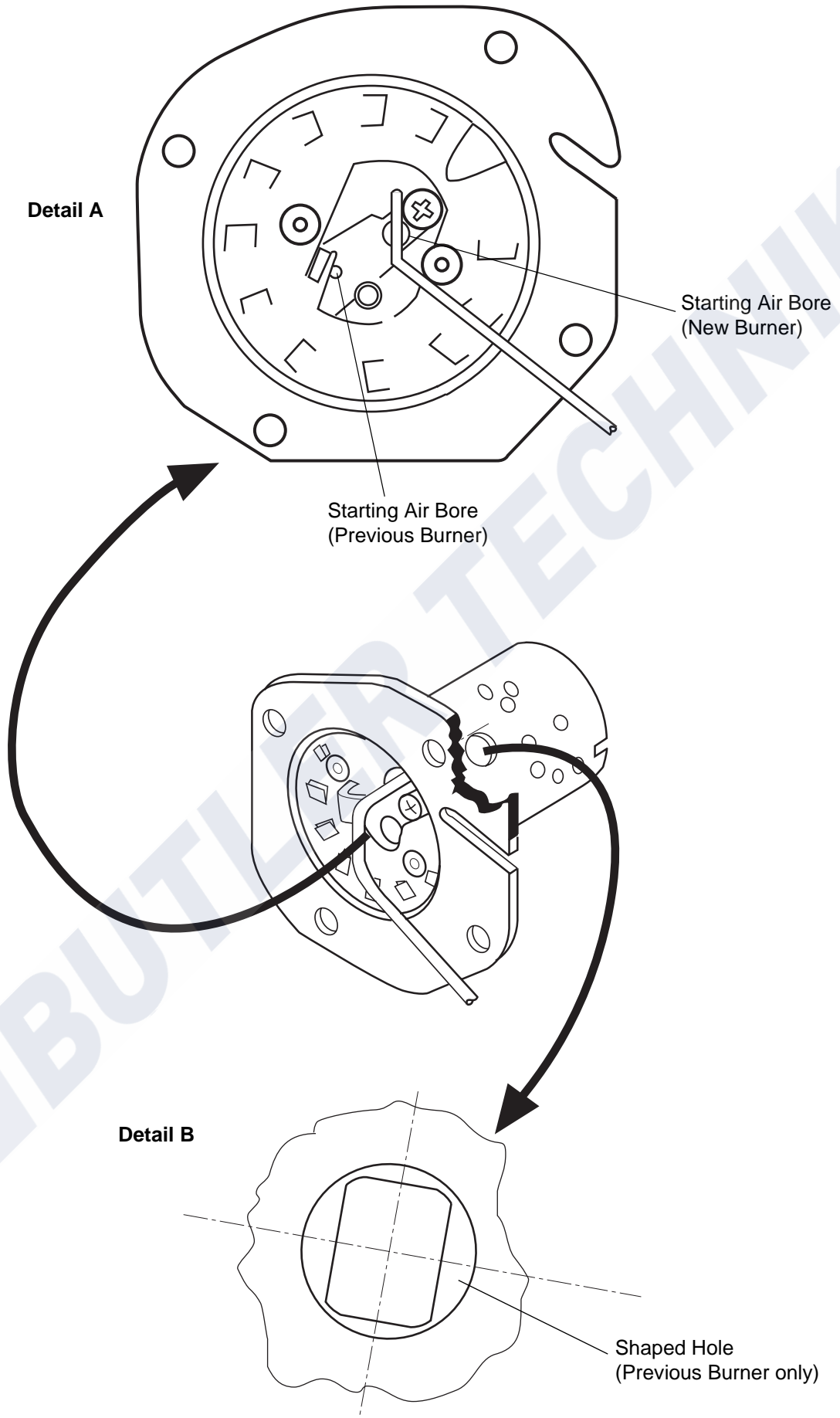

Fig. 904 Disassembly of Heat Exchanger (Sheet 2 of 2)

9.2.7 Replacement of Burner Insert, Combustion Tube, and Heat Exchanger

9.2.7.1 Removal

CAUTION

When replacing the heat exchanger, the temperature sensor must also be replaced.

1. Remove air heater (see 8.7.1.1).
2. Remove control unit (see 8.7.2.1).
3. Remove combustion air fan (see 9.2.4.1).
4. Remove flame sensor (see 9.2.5.1).
5. Remove glow plug (see 9.2.6.1).

CAUTION

When performing the following step ensure that fuel connection is not bent.

6. Remove burner insert (5, Fig. 904).
7. Withdraw combustion tube (6) from heat exchanger (8) and remove gasket (7).
8. Perform work on components after disassembly (see 9.1.1).

9.2.7.2 Installation

1. In case a new heat exchanger is fitted, secure temperature limiter (5, Fig. 815) with new Ejot DG screws (4) and torque to 1 ± 0.1 Nm.
2. Fit new gasket (7, Fig. 904).
3. Bring combustion tube (6) in assembly position.

NOTE

The burner insert will be secured when installing flame sensor and glow plug.

CAUTION

When performing the following step ensure that the fuel connection is not bent.

4. Install glow plug (see 9.2.6.2).
5. Install flame sensor (see 9.2.5.2).
6. Mount combustion air fan (see 9.2.4.2).
7. Install control unit (see 8.7.2.2).
8. Install air heater (see 8.7.1.2).

10 Packaging/Storage and Shipping

10.1 General

The air heater and its components shipped to Webasto Thermosysteme GmbH for inspection or repair are to be cleaned and packaged so that they are protected against damage during handling, transportation, and storage.

In storage an ambient temperature of +85° C and –40° C must not be exceeded.

BUTLER TECHNIK