

Air heaters

Installation instructions

Air Top 2000

Trade names

Air Top 2000 B (petrol)

Air Top 2000 D (Diesel)

07/2004

Table of contents

1	Statutory regulations governing installation	39
2	Use and version	41
3	Installation.....	42
4	Factory plate	45
5	Installation diagram.....	46
6	Installation example	47
7	Hot air system.....	48
8	Fuel supply.....	50
9	Combustion air supply.....	55
10	Exhaust pipe	56
11	Combustion air inlet and exhaust lines.....	57
12	Electrical connections	59
13	Circuit diagrams	63
14	Starting the heater for the first time	72
15	Fault lock-out.....	73
16	Technical data.....	74
17	Drilling template	76

BT BUTLER TECHNIK

1 Statutory regulations governing installation

The Air Top 2000 heater has been type-tested and approved in accordance with EC Directives 72/245/EEC (EMC) and 2001/56/EC (heater) with the following EC permit numbers:

e1*72/245*95/54*1085*--
e1*2001/56*0013*--

Installation is governed above all by the provisions in Annex VII of Directive 2001/56/EC.

NOTE:

The provisions of these Directives are binding within the territory governed by EU Directive 70/156/EEC and should similarly be observed in countries without specific regulations.

(Extract from Directive 2001/56/EC Annex VII)

1.7.1. A clearly visible indicator within the user's field of vision must show when the heater is switched on or off.

2. Regulations for installation in the vehicle

2.1. Scope

2.1.1. Subject to the provisions of paragraph 2.1.2, internal combustion heaters must be installed in accordance with the requirements contained in this Annex.

2.1.2. In the case of class O vehicles of class O (*trailers*) with heaters for liquid fuel, it is presumed that these vehicles comply with the requirements in this Annex.

2.2. Position of the heater

2.2.1. Parts of the vehicle body and other components in the immediate vicinity of the heater must be protected against excessive heat and the danger of contamination by fuel or oil.

2.2.2. The internal combustion heater must not pose a fire hazard even when overheated. This requirement is deemed to have been met if care is taken during installation to ensure an adequate distance from all parts, as well as adequate ventilation and if fire-resistant materials or heat shields are used.

2.2.3. For class M₂ and M₃ vehicles the heater must not be installed in the passenger cabin. A device in a sealed cover, which also meets the requirements set out in paragraph 2.2.2, may be used, however.

2.2.4. The plate mentioned in paragraph 1.4 (*model plate*) or a duplicate thereof (*duplicate model plate*) must be fitted in such a way that it is still clearly legible when the heater has been installed in the vehicle.

2.2.5. When positioning the heater, all reasonable precautions must be taken to minimise the risk of personal injury or damage to items in the vehicle.

2.3. Fuel supply

2.3.1. The fuel filler neck must not be located in the passenger compartment and must have a tightly fitting cap to prevent any fuel leaks.

2.3.2. The type of fuel and the fuel filler neck must be clearly identified on heaters for liquid fuel, for which the fuel supply is separate from the fuel supply for the vehicle.

2.3.3. A sign must be affixed to the fuel filler neck warning that the heater must be switched off before refuelling. An identical warning must also be included in the manufacturer's operating instructions.

2.4. Exhaust system

2.4.1. The exhaust outlet must be positioned in such a way that exhaust fumes cannot get into the interior of the vehicle through ventilation devices, hot-air inlets or open windows.

2.5. Combustion air inlet

2.5.1. The air for the combustion chamber of the heater must not be extracted from the passenger cabin of the vehicle.

2.5.2. The air inlet must be positioned in such a way that it cannot be obstructed by other objects.

2.6. Hot air inlet

2.6.1. The supply of heating air must consist of either fresh air or recirculated air and must be taken from a clean area which cannot be contaminated by exhaust fumes from the engine, the internal combustion heater or any other source in the vehicle.

2.6.2. The inlet line must be protected by a grating or other suitable means.

2.7. Hot air outlet

2.7.1. Hot air lines within the vehicle must be positioned or protected in such a way as to exclude all risk of injury or damage caused by direct contact.

2.7.2. The air outlet must be positioned or protected so that it cannot be obstructed by other objects.

2.8. Automatic control of the heating system

When the engine stops, the heating system must cut out automatically and the fuel supply must be stopped within 5 seconds.

The heating system may remain in operation if a manual unit has already been activated.

IMPORTANT

Failure to follow the installation instructions and the notes contained therein will lead to all liability being refused by Webasto. The same applies if repairs are carried out incorrectly or with the use of parts other than genuine spare parts. This will result in the invalidation of the type approval for the heater and therefore of its *homologation / EC type licence*.

2 Use and version

2.1. Use of the air heaters

The Webasto Air Top 2000 air heaters are designed

- to heat passenger cabins
- to defrost vehicle windows.

The heaters operate independently of the engine and are connected to the fuel tank and the electrical system of the vehicle.

They may be used for vehicles with either water or air-cooled engines.

2.2. Version

Air Top 2000 B (petrol)

Air heater for petrol (12 V)

Air Top 2000 D (diesel)

Air heater for diesel/EL heating oil (12 or 24 V)

Installation

3 Installation

IMPORTANT

The statutory regulations governing installation on pages 1 and 2 must be adhered to. The requirements of the latest version of the ADR must also be observed for the installing the heater into vehicles used to transport hazardous substances.

The heater must not be operated without the control unit cover (this will cause the heater to overheat).

3.1. Air Top 2000 installation situation

NOTE:

Check the installation situation of the relevant vehicle type.

3.2. Installation location

The heater must be installed in the interior of the vehicle (except in buses, see statutory regulations).

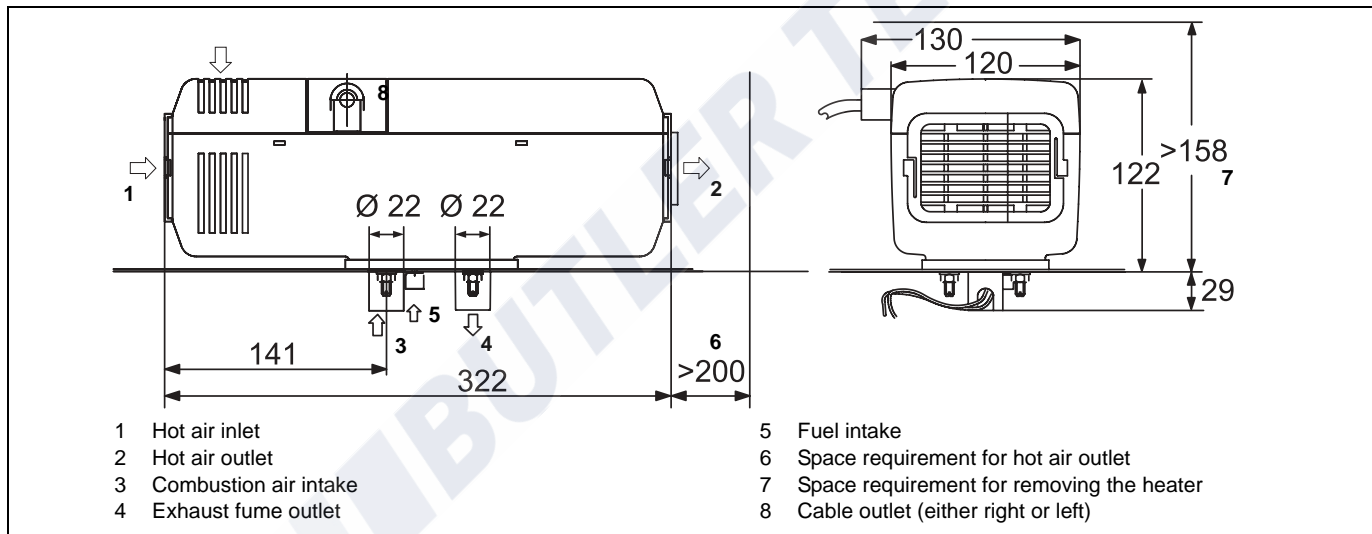

Fig. 1: Dimensions of the heater

If the heater is installed in an installation box, it may be installed on the exterior of the vehicle and operate in air circulation mode. The installation box must be purchased from Webasto or its design must be approved by Webasto.

The openings for the combustion air inlet port, the exhaust outlet port and the fuel pipe must be sealed splashing water if the heater is installed in the interior. The seal designed and supplied for this purpose must be used (see Figure 4). **This seal must be replaced each time the heater is installed.**

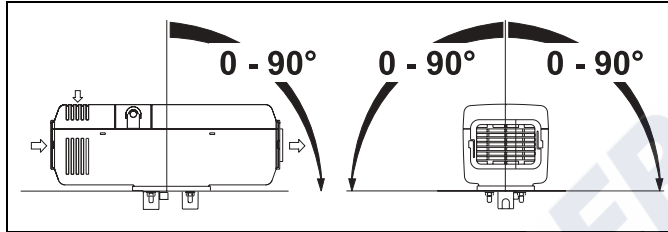

Fig. 2: Recommended installation positions for diesel heaters

3.3. To install the heater

The M6 nuts must be tightened with a torque of 6 Nm +1 Nm for installing the Air Top 2000 heater.

The installation dimensions and space requirement for service access are shown in the installation drawing (Figure 1). The specified horizontal and axial angles must not be exceeded (Figure 2).

We recommend that petrol heaters be installed with the exhaust port pointing vertically downwards.

NOTE:

Other installation positions may cause the burner to suffer increased wear.

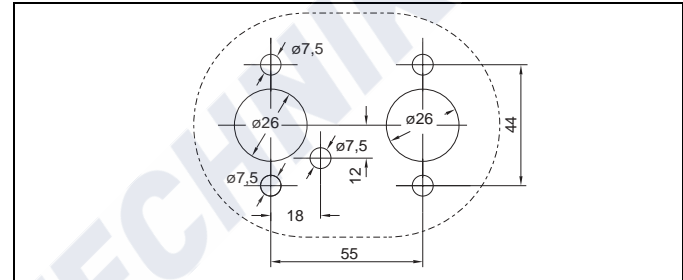

Fig. 3: Hole pattern

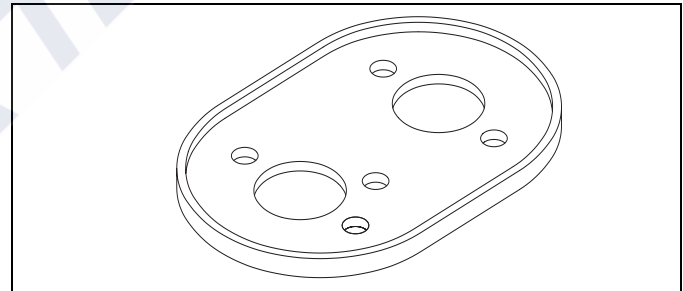

Fig. 4: Seal

A seal (Figure 4) must be fitted between the heater and the vehicle body. **This seal must be replaced each time the heater is installed.** The support area for the heater foot **must be flat**. A special tool can be purchased from the manufacturer to drill the holes and, if necessary, smooth the support area. The seal can compensate for unevenness of max. 1 mm.

IMPORTANT

After installation, check that the casing is not in contact with any parts of the vehicle body. A failure to do this may result in the hot air fan blocking.

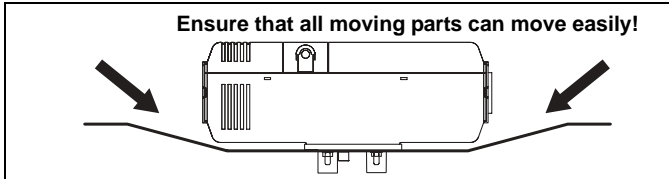

Fig. 5: Installation

4 Factory plate

The model plate must be positioned so that it cannot be damaged and must be clearly legible when the heater is installed (otherwise a duplicate model plate must be used).

Inapplicable years must be erased from the model plate.



5 Installation diagram

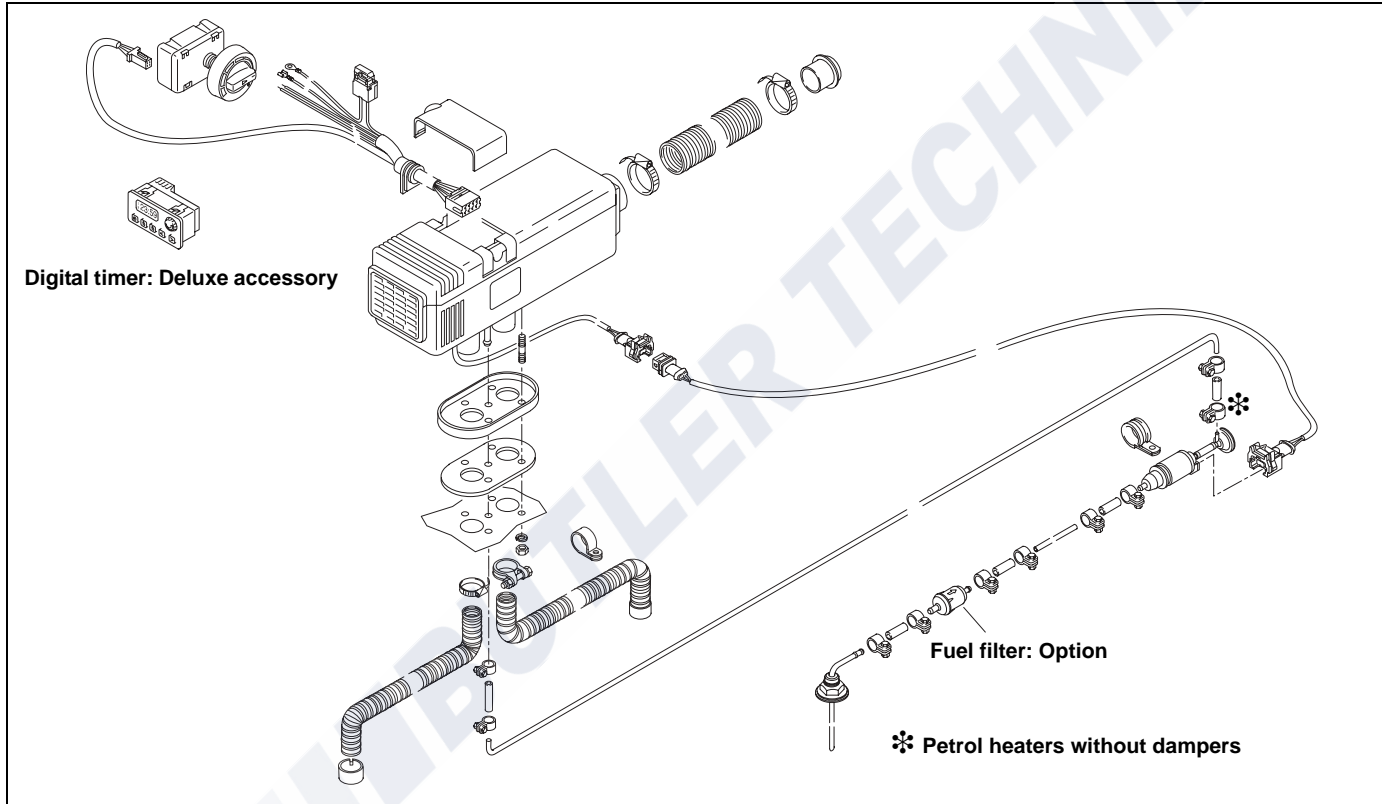

Fig. 6: Installation diagram for air heater

6 Installation example

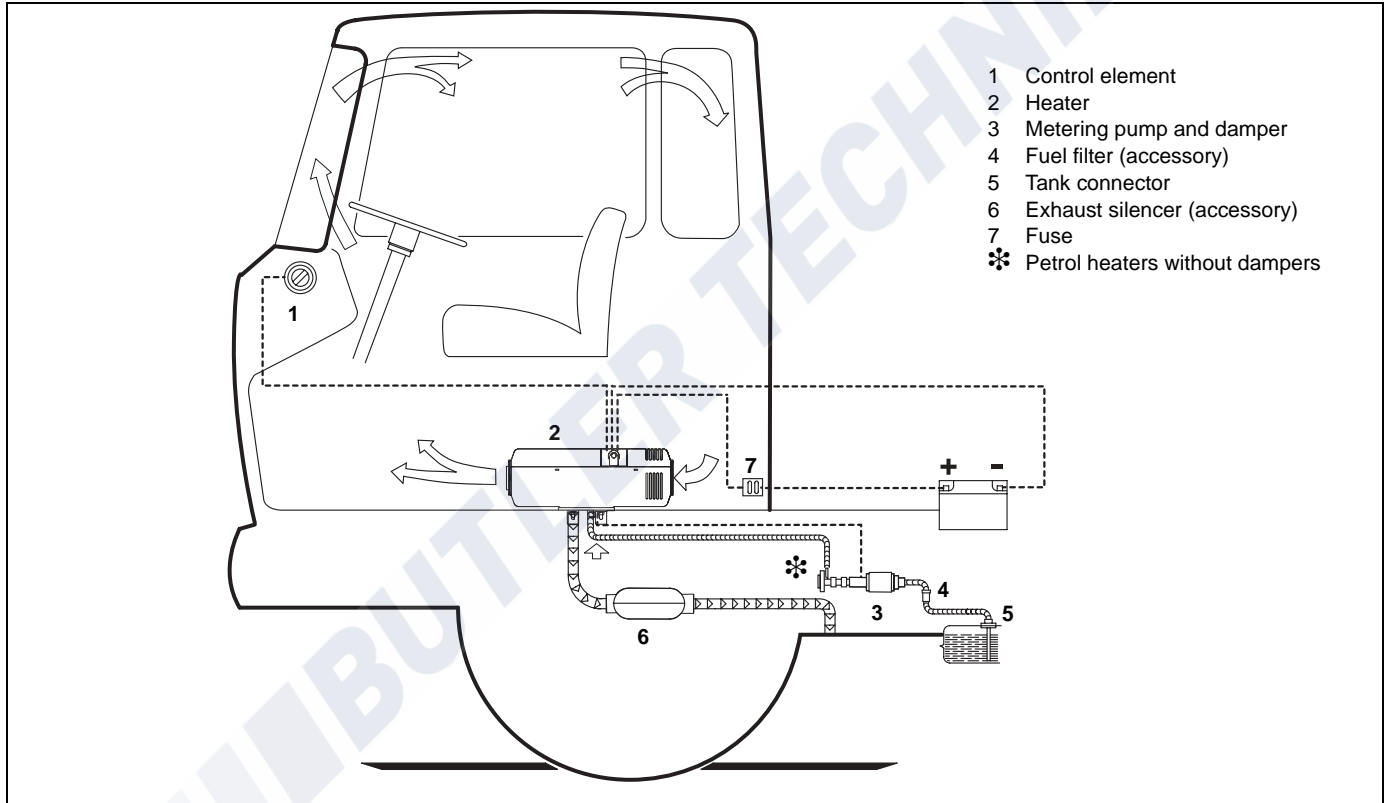

Fig. 7: Installation example for air heater

Hot air system

7 Hot air system

NOTE:

The heater must not be integrated into the vehicle's air system.

The air heater can only be used in air circulation mode.

A temperature sensor is installed in the heater on the hot air intake side, which operates the heater in the appropriate heat output range in conjunction with the control element depending on the intake temperatures and the position of the setpoint generator. The heat output is set such that after the selected interior temperature has been reached quickly, it is then kept at this selected value.

Minimum internal diameter of the hot air line 55 mm (nominal diameter 60 mm).

NOTE:

Only materials that can withstand temperatures of at least 130°C may be used for the hot air line. The hot air opening is to be positioned in such a way that the air is not blown on to any parts that cannot withstand the heat.

IMPORTANT

In vehicles used to convey passengers the air output opening is to be positioned so that nobody can be located in front of the air output.

Maximum pressure drop between the inlet and outlet side of the hot air line: 1.0 hPa

1 hPa corresponds to 1 mbar corresponds to 10 mm WC.

If this value is exceeded the temperature limiter will trip. The hot air hose must be secured at its connection points.

If the heater is used in air circulation mode, it may be used without any accessories for controlling the hot air (a short circuit of the hot air current must be avoided).

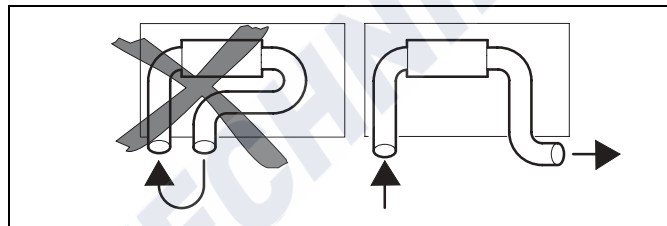

Fig. 8: Hot air inlet and hot air outlet

NOTE:

The installation must be checked for:

- Air short circuit between the vehicle's heating system and the heater air inlet.
 - Air short circuit between the heater's air inlet and the heater's air outlet (Figure 8).
 - Adequate hot air intake facility (take the air intake from the cool area of the cabin, for example for installations under a bench).
- If you use an installation box the air vent must be sealed in such a way that no hot air can get into the installation box.

7.1. External temperature sensor

We recommend that you install an external temperature sensor if the heater is installed in an installation box or in places with poor ventilation (for example under benches). This will prevent the heater having very short control times.

7.1.1. To install the external temperature sensor

The external temperature sensor must be installed at medium height in the passenger cabin on vertical surfaces if possible in the area that requires heating.

The temperature sensor must **not**

- be in the direct current of hot air (from the vehicle's own heating system or the hot air heater).
- be close to heat sources (for example the vehicle's own heating system).
- be placed in direct sunlight (for example on the dashboard).
- be installed behind curtains or the like.

Fuel supply

8 Fuel supply

The fuel is taken from the vehicle fuel tank or from a separate fuel tank. The values for the maximum pressure at the fuel extraction point are shown in Figure 9.

Permissible fuel inflow height H (m)	At max. pressure (bar) in fuel line
0.00	0.2
1.00	0.11
2.00	0.03
Maximum fuel intake height S (m)	At max. negative pressure (bar) in the fuel tank
0.00	-0.10
0.50	-0.06
1.00	-0.02

Only for ADR: The statutory regulation of ADR (Accord européen relatif au transport international des marchandises dangereuses par route) governing fuel tanks, part 9 para. 9.2.4.7, must be adhered to.

A sign must be affixed to the fuel filler neck warning that the heater must be switched off before refuelling.

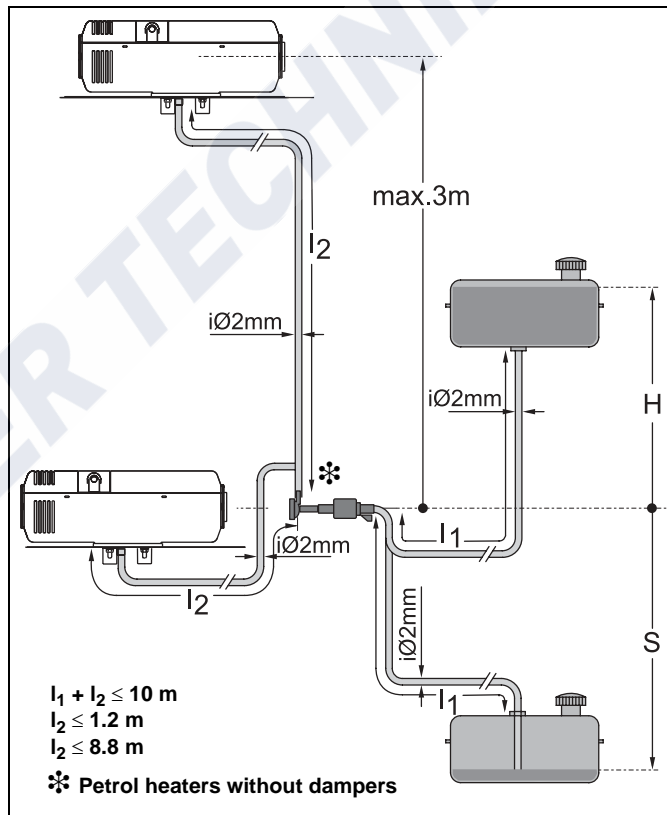

Fig. 9: Fuel supply

8.1. Vehicles with carburettor engines

The fuel may only be extracted using the special Webasto fuel extractor (see Figure 10) as close to the tank as possible. The connection may be made in either the supply or return line, in which case the return line must lead almost to the base of the tank. If this is not the case the return line may be extended.

The fuel extractor must be fitted in such a way that any air or gas bubbles are automatically discharged towards the tank (see Figure 10).

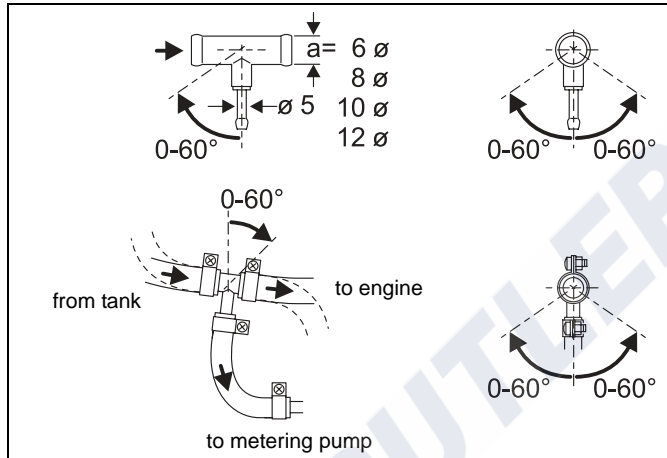

Fig. 10: Webasto fuel extractor

The fuel extractor should not be located near the engine, as gas bubbles may form in the lines on account of heat radiated from the engine. This may cause problems during combustion.

8.2. Vehicles with injection engines

When installing the heater in a vehicle with fuel injection system, it is important to establish whether the fuel pump is located inside or outside the tank.

If the fuel pump is located inside the tank, fuel can only be extracted from the return line using the Webasto fuel extractor (see Figure 10), in which case it must be ensured that the return line continues almost to the bottom of the tank (see Figure 11 for details of the minimum distance from the bottom of the tank). If this is not the case Webasto fuel extractor (see Figure 11, 12 and 13) may be used.

If the fuel pump is installed outside the tank, the fuel connection may also be made between the tank and the fuel pump, again using only the Webasto fuel extractor (see Figure 10).

8.3. Vehicles with diesel engines

The fuel must be taken from the vehicle fuel tank or from a separate tank (see Figs. 11, 12 and 13). This separate fuel pickup precludes any effect of pressure.

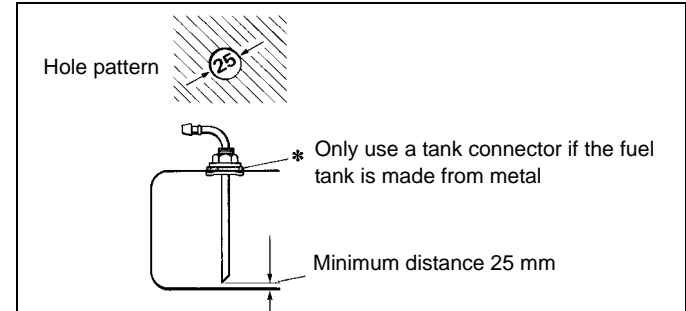

Fig. 11: Webasto tank connector

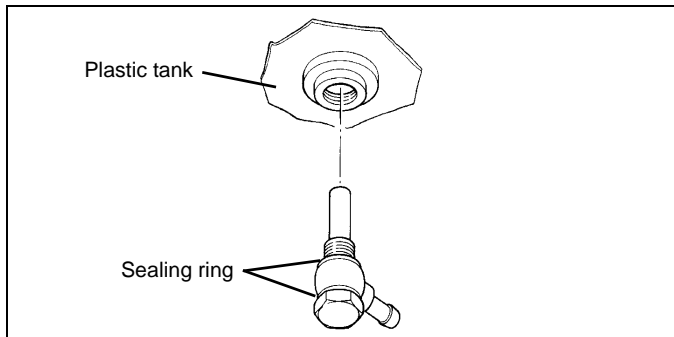

Fig. 12: Fuel pickup from the plastic tank
(Pickup via tank drain screw)

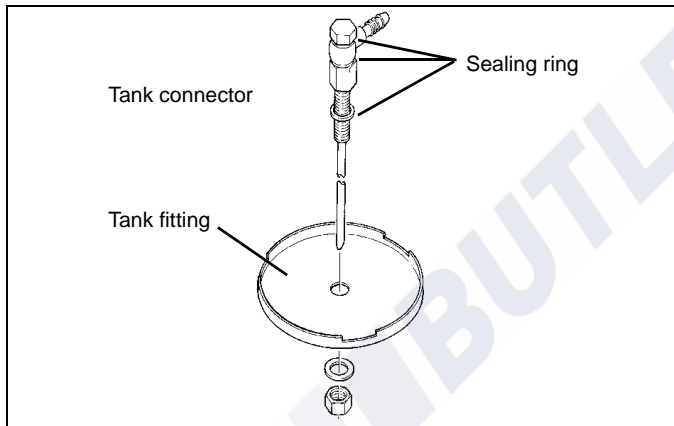

Fig. 13: Fuel pickup from the plastic tank
(Pickup via tank fitting)

NOTE:

The tank fitting must be made from metal!

8.4. Fuel lines

Only steel, copper and plastic lines of plasticised, light and temperature-stabilized PA 11 or PA 12 (e.g. Mecanyl RWTL) pursuant to DIN 73378 may be used for the fuel lines.

Since the lines normally cannot be routed with a constant rising gradient, the internal diameter must not be allowed to exceed a certain size. Air or gas bubbles will accumulate in lines with an internal diameter of more than 4 mm and these will cause malfunctions whilst the heater is operating if the lines sag or are routed downwards. The diameters specified in Figure 9 will ensure that bubbles do not form.

The lines should not be routed downwards from the metering pump to the heater.

Unsupported fuel lines must be secured to prevent them sagging. They must be installed in such a way that they cannot be damaged by flying road chippings and high temperatures (exhaust line).

The fuel lines must be secure at the connections using hose clips to prevent their slipping.

8.4.1. Connecting two pipes with a hose

The correct procedure for connecting fuel lines with hosing is shown in Figure 14.

Ensure that there are no leaks.

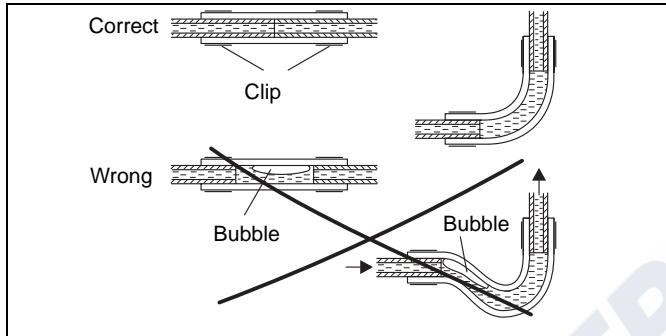

Fig. 14: Pipe / hose connection

8.5. Dosing pump

The metering pump is a combined delivery, metering and shut-off pump and is subject to certain installation criteria (see Figures 9, 15 and 16).

8.5.1. Installation location

It is advisable to install the metering pump in a cool place. The maximum ambient temperature must not exceed +20°C at any time during operation.

The metering pump and fuel lines must not be installed within range of the radiated heat from hot vehicle parts. A heat shield must be used if necessary.

Air Top 2000. 12 Volt – petrol

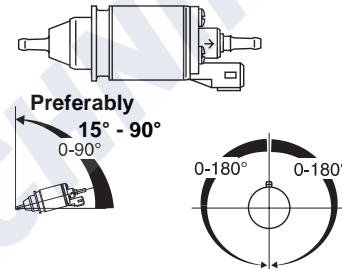

Fig. 15: Metering pump DP 2
Installation position and attachment

Air Top 2000 D. 12 Volt und 24 Volt – diesel

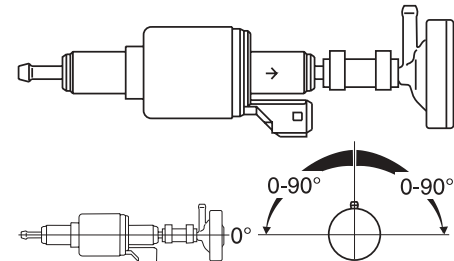

Fig. 16: Metering pump DP 30
Installation position and attachment

Fuel supply

8.5.2. Installation and attachment

The metering pump must be secured with a vibration-damping mounting. Its installation position is limited as shown in Figures 15 and 16 in order to ensure effective automatic bleeding.

As a result of the risk of corrosion, only genuine Webasto parts may be used for the plug connections between the metering pump and the metering pump wiring harness.

8.6. Fuel filter

Only a Webasto filter, order no. 487 171, is allowed to be used if the fuel is expected to be contaminated. Install vertically if possible, however at least horizontally (check flow direction).

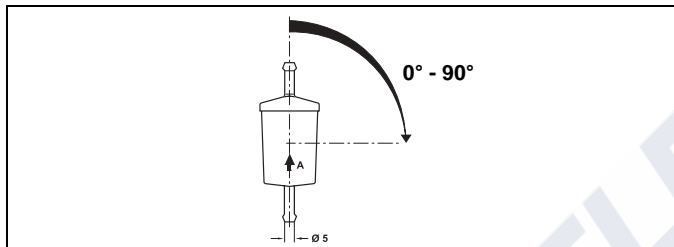

Fig. 17: Fuel filter

9 Combustion air supply

Under no circumstances may the combustion air be taken from areas occupied by people. The combustion air intake opening must not point in the direction of travel. It must be located so that it cannot become clogged with dirt.

NOTE: For petrol heaters only.

The combustion air must be extracted using a combustion air line (if necessary) from a position that is as cool as possible and protected from splashing water.

If the heater is in a sealed installation box, the combustion air must be drawn in from the outside and the emissions fed to the outside. Pipe passage holes must be made in such a way as to ensure that the ingress of exhaust fumes into the interior of the vehicle should not occur.

See the statutory regulations for the installation for further regulations.

Exhaust pipe

10 Exhaust pipe

Rigid pipes of unalloyed or alloyed steel with a minimum wall thickness of 1.0 mm or flexible piping of alloyed steel only must be used as exhaust line.

The exhaust pipe is secured to the heater using a clamping collar, for example. See the statutory regulations for other requirements.

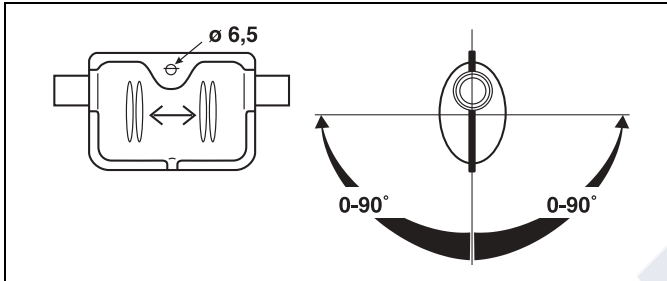

Fig. 18: Exhaust silencer

Flow direction (arbitrary)

The exhaust silencer should ideally be installed near the heater.
The heater may also be operated without a silencer.

11 Combustion air inlet and exhaust lines

Both lines are to be installed falling away from the heater. If this is not possible, a condensate drain hole with a diameter of 5 mm must be made at its lowest point.

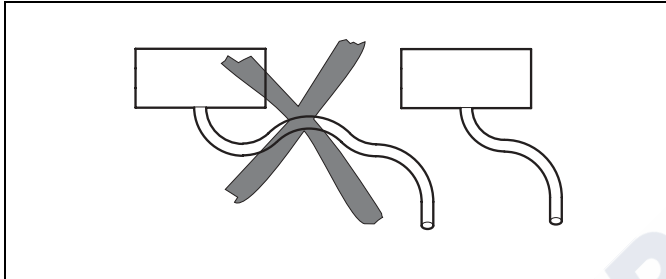

Fig. 19: Prevent the formation of condensate

The lines must not point to the front of the vehicle.

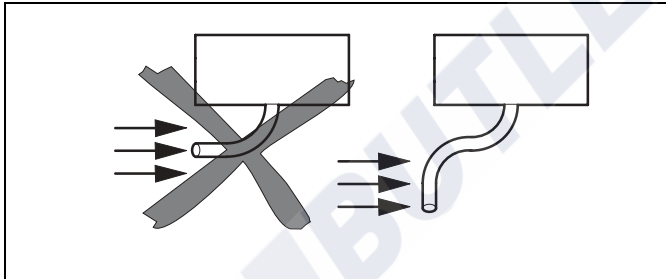

Fig. 20: The lines must not end pointing towards the front of the vehicle

The lines must be located so that they cannot become clogged with dirt.

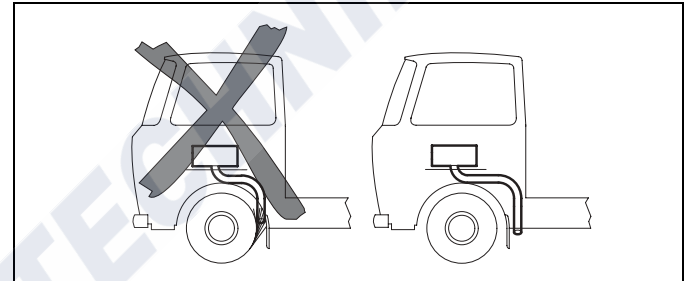

Fig. 21: Avoid the air outlet area

IMPORTANT

If the exhaust pipe ends is other than as shown in the Figure 22 it will pose a fire risk.

To prevent damaging the metering pump cable, exhaust line must not be used to extend the combustion air supply line.

Length of the combustion air inlet and exhaust lines in total:

With silencer:	max. 2.0 m
Without silencer:	max. 5.0 m

NOTE:

If the exhaust line is over 2 m in length, insulated lines must be used (to prevent falling below the dewpoint)

Internal diameter of the lines:

Combustion air line:	22 mm
exhaust line (metal):	22 mm

Minimum bending radius: 50 mm

Total bends:

Combustion air line: max. 270°

Exhaust line: max. 270°

An attachment is required no further than 150 mm from the end of the exhaust pipe to ensure that the angle of $90^\circ \pm 10^\circ$ is achieved

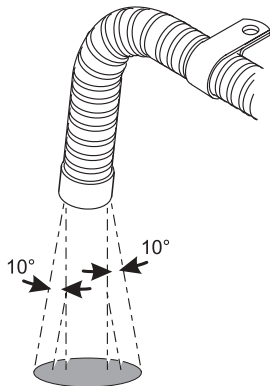

Discharge direction almost vertical $90^\circ \pm 10^\circ$

Fig. 22: Exhaust pipe opening
Installation position

Only for ADR: The statutory regulation of ADR (Accord européen relatif au transport international des marchandises dangereuses par route) governing the routing of the exhaust line, part 9 para. 9.2.4.7, must be adhered to.

12 Electrical connections

All the cables that are not required must be insulated.

NOTE:

If the combination or standard timer is used, a touch-sensitive switch may be installed in the sleeping section to act as a remote control and improved convenience. The connections must be made as shown in the circuit diagrams in Figures 31 and 32, 34 or 35.

The electrical connection is made as shown in the system circuit diagram (Figures 30, 31, 32, 33, 34, 35 or 36).

12.1. Connection for installing the heater in a hazchem vehicle (ADR)

To install the Air Top 2000 D heater in hazchem vehicles, the requirements of ADR/RID part 9 para. 9.2.4.7 – Combustion heating systems, must also be satisfied. The electrical connection is made as shown in the circuit diagram, Figs. 33, 34 or 35. On vehicles without a power take-off the electrical connection must be made as shown in the system wiring diagram in Figure 36.

NOTE:

The switch S4 must be installed in such a way that a positive potential is connected to appropriate input of the control module when a pumping device is switched on.

IMPORTANT

All ADR functions are ineffective if there is no earth at control unit input X11/2 when the system is switched on. The control unit continues to run briefly for 20 seconds and then switches to "fault lock-out" operating mode when a positive voltage is connected to control unit input X11/2 (auxiliary power take-off on) or the engine is switched off.

IMPORTANT

In accordance with the regulations of the act governing the road/rail haulage of hazardous materials, heaters are only allowed to be taken into service with a special manually operated switch fitted in the cab. If the system is equipped with a combination or standard clock, ensure that contact 4 on the combination or standard clock remains free. The heater can then only be taken into service using the immediate heat button.

The use of other timers in ADR vehicles is not permitted.

12.2. Heater connection

To connect the wiring harness, remove the control unit cover on the heater and connected the wiring harness plug to the control unit.

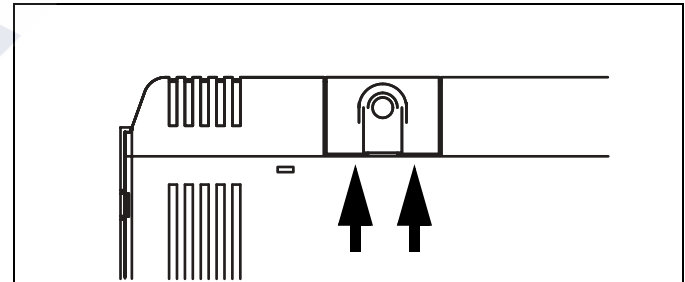

Fig. 23: To remove the control unit cover

NOTE:

Raise the control unit cover on both sides using a blunt blade (Figure 23 arrows).

Contact with the printed conductors on the control unit must be avoided (electrostatic discharge).

Before using the heater for the first time fit the control unit cover to prevent the illegal escape of hot air (heater overheating).

The cable passage can be placed at either the left or right side.

To ensure that the cable passage in the control unit cover seals perfectly, the cable grommet is to be adjusted appropriately on the wiring harness.

12.3. Supply voltage connection

Ideally from the vehicle's central electrical system.

An additional blade terminal fuse holder is to be fitted to protect the heater (supplied with the heater). The fuse holder may only be installed in the interior of the vehicle.

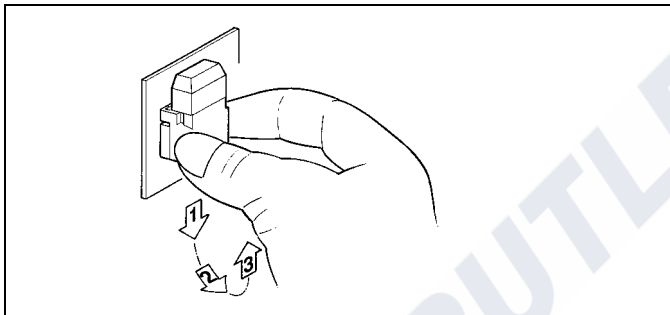

Fig. 24: Remove the fastening plate on the fuse holder

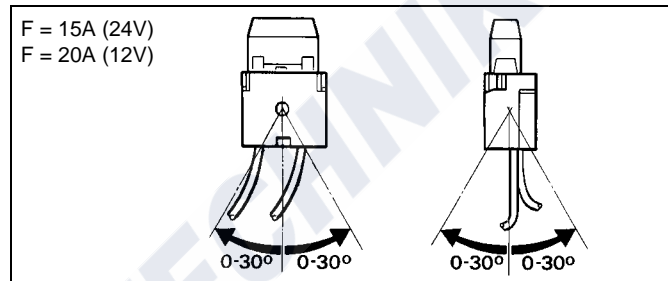

Fig. 25: Fuse holder, installation position

12.4. Control element connection

The wiring harness is (mechanically) prepared for connection to the setpoint generator.

Simply pull on connector housing to unplug the connector.

The connector housing can be locked (self-locking action) by simply pulling on the wiring harness.

NOTE:

The fibre optic cable must be in contact with the rotary knob.

NOTE:

As an option an external temperature sensor may be installed in the passenger cabin (see page 48).

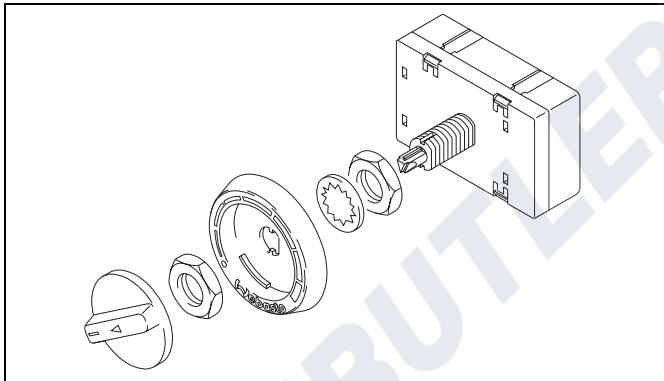

Fig. 26: Control element

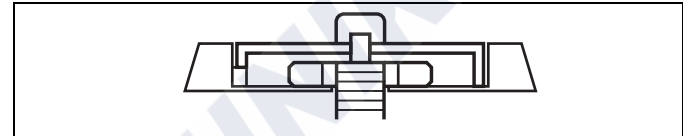

Fig. 27: Installation of the control element

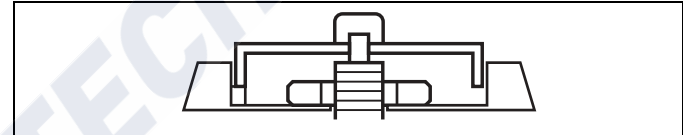

Fig. 28: Installation of the control element (incorrect)

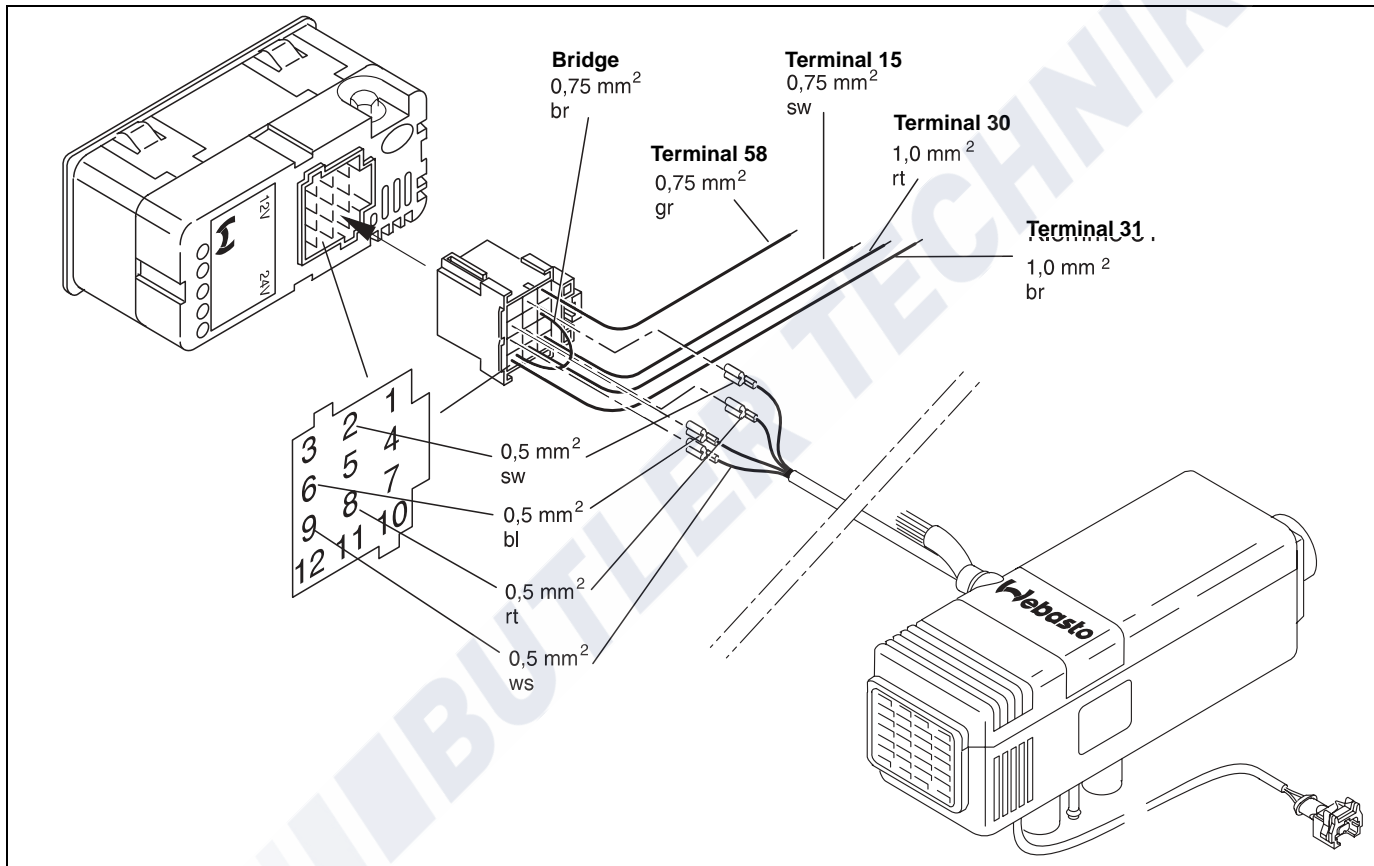

Fig. 29: Connection diagram for the Air Top 2000, deluxe version

13 Circuit diagrams

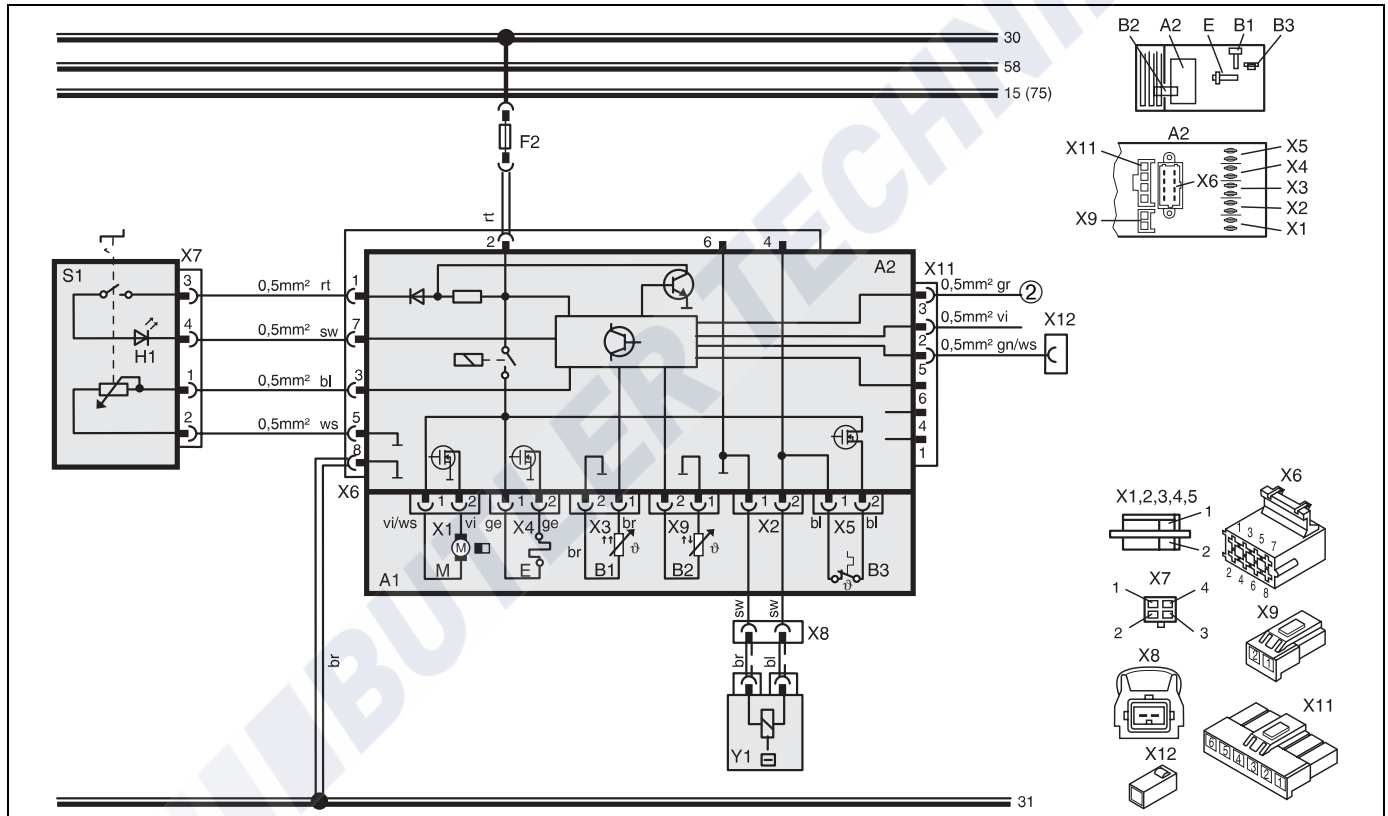

Fig. 30: Automatic circuit diagram for the Air Top 2000, 12V/24V with control element, for legend see pages 70 and 71

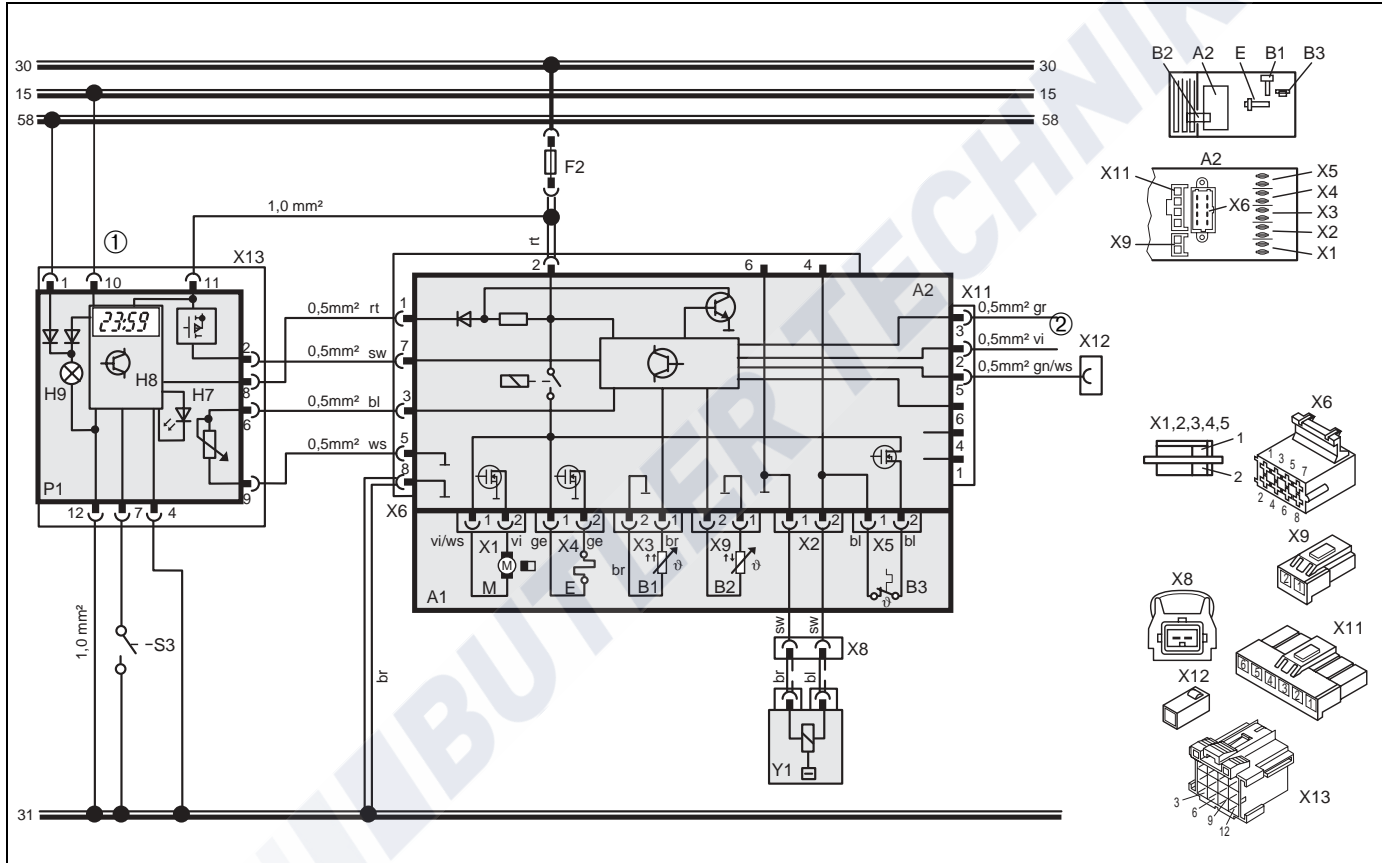

Fig. 31: Automatic circuit diagram for the Air Top 2000, 12V/24V with combination timer, for legend see pages 70 and 71

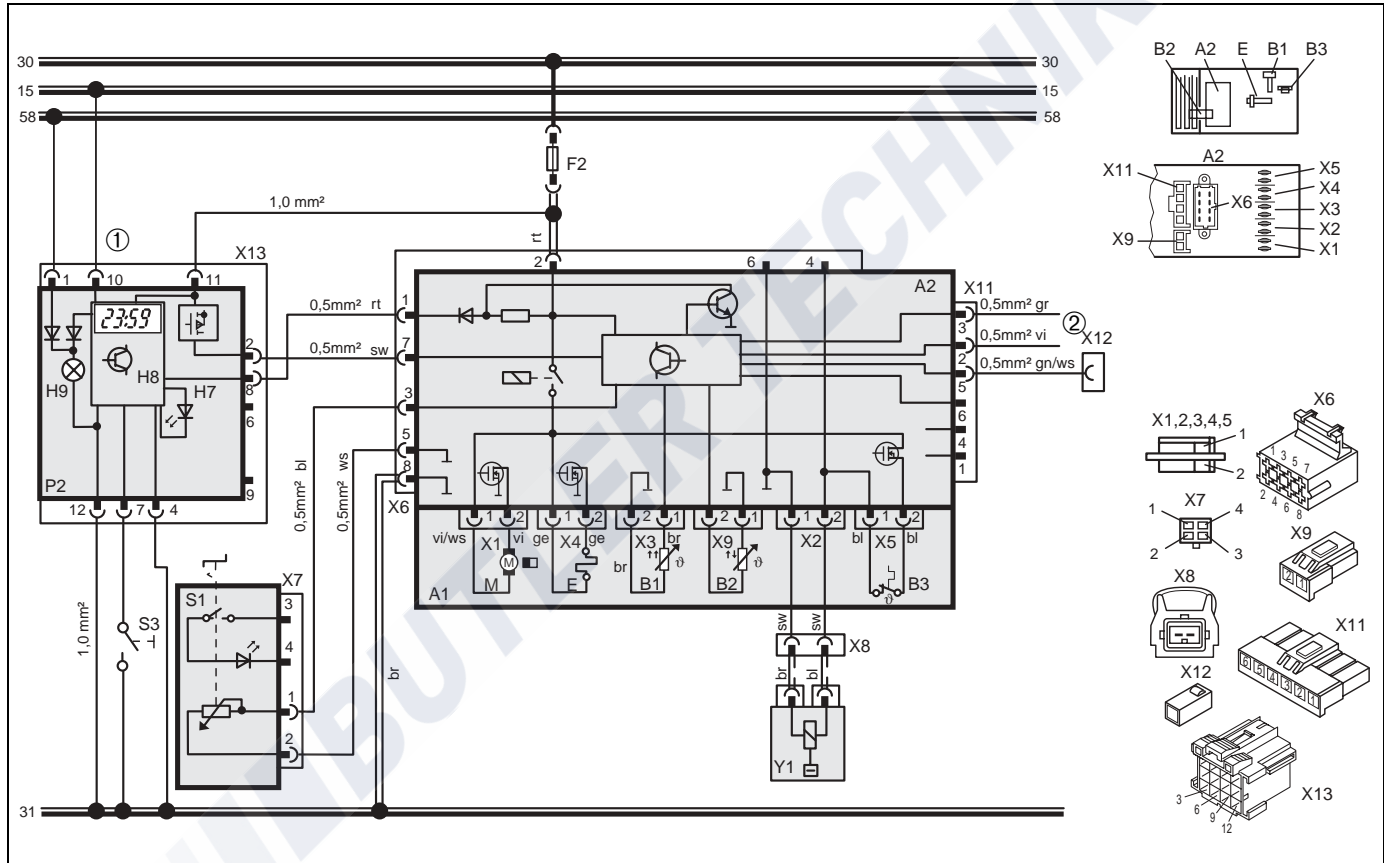

Fig. 32: Automatic circuit diagram for the Air Top 2000, 12V/24V with control element and combination timer, for legend see pages 70 and 71

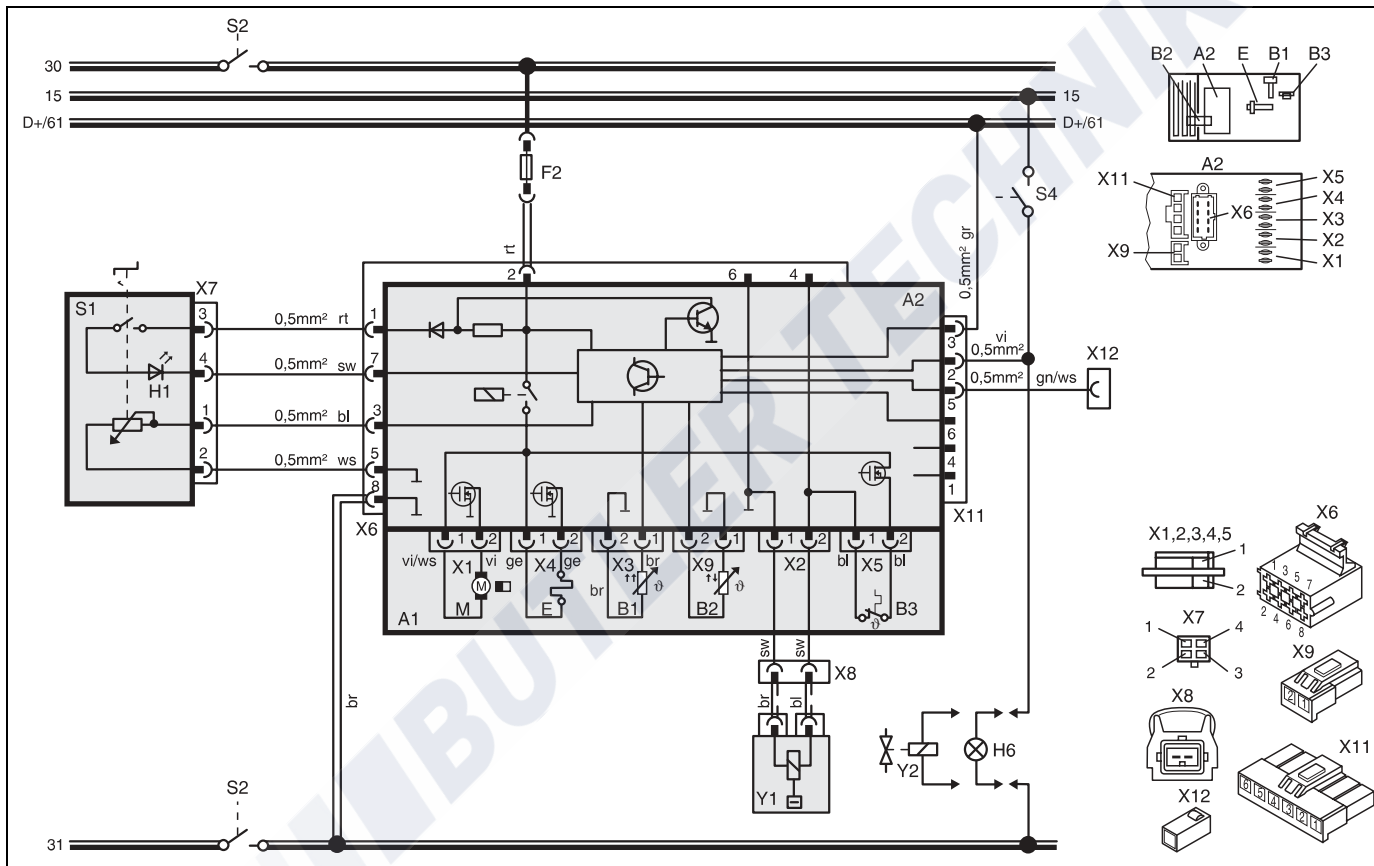

Fig. 33: Automatic circuit diagram for the Air Top 2000, 24V ADR mode with control element, for legend see pages 70 and 71

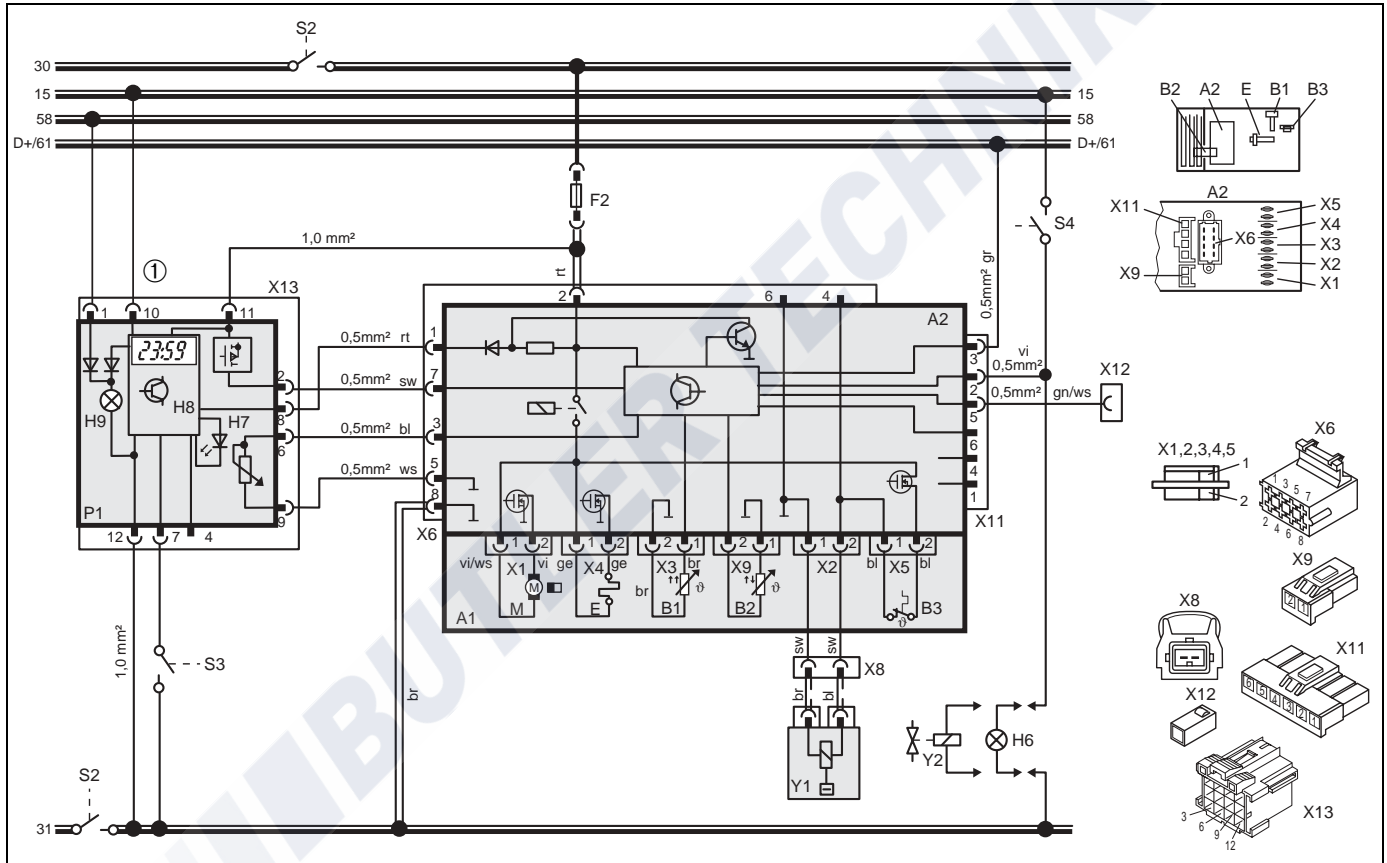

Fig. 34: Automatic circuit diagram for the Air Top 2000, 24V ADR mode with combination timer, for legend see pages 70 and 71

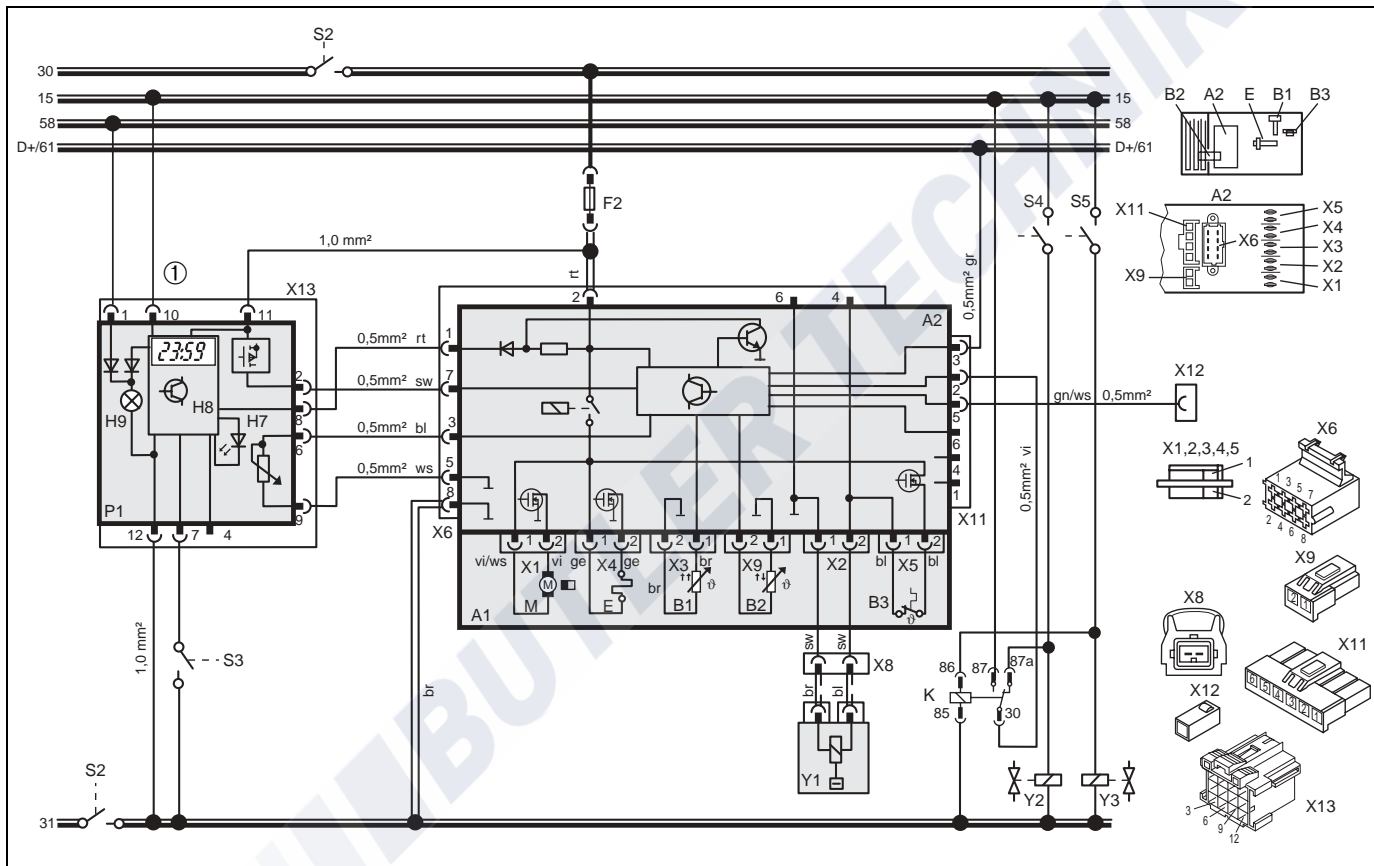

Fig. 35: Automatic circuit diagram for the Air Top 2000, 24V ADR mode with combination timer and two auxiliary drive units, for legend see pages 70 and 71

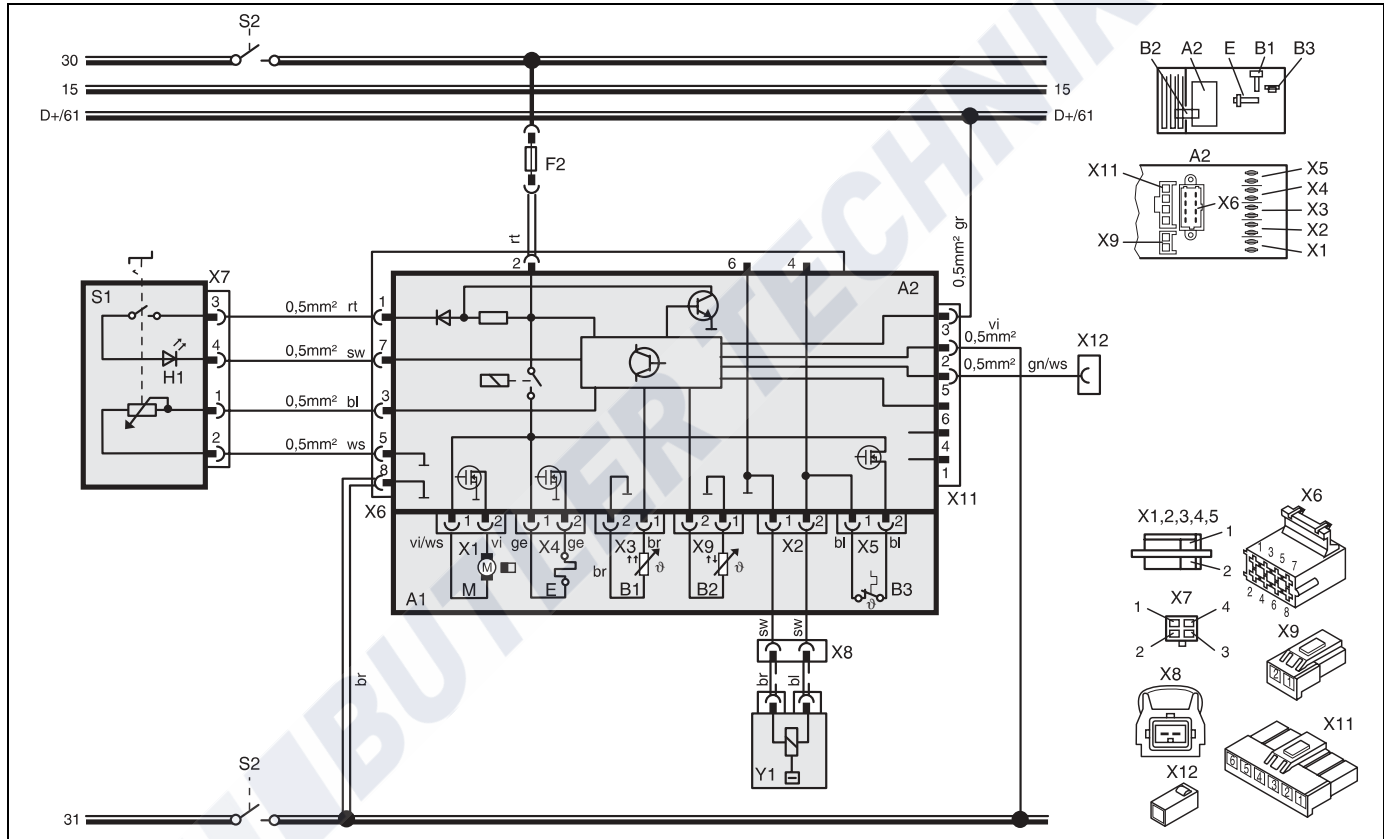







Fig. 36: Automatic circuit diagram for the Air Top 2000 diagnostic, 24V ADR mode with control element for vehicles without auxiliary drive unit, for legend see pages 70 and 71

Circuit diagrams

13.1. Legend for circuit diagrams

- ① With positive from terminal (15/75) to connection 10:
Permanent operation for immediate heat as long as the ignition is switched on
Without positive at connection 10:
Heating time is variably programmable (10 min to 120 min), default setting 120 min
- ② Connections X11/2 and X11/3 for ADR function only

Cable cross-sections		
	< 7.5 m	7.5 - 15 m
	0.75 mm ²	1.0 mm ²
	1.0 mm ²	1.5 mm ²
	1.5 mm ²	2.5 mm ²
	2.5 mm ²	4.0 mm ²
	4.0 mm ²	6.0 mm ²

Cable colours	
bl	blue
br	brown
ge	yellow
gn	green
gr	grey
or	orange
rt	red
sw	black
vi	violet
ws	white

Item	Description	Comment
A1	Heater	Air Top 2000.
A2	Control module	
B1	Flame sensor	
B2	Temperature sensor	
B3	Overheating guard	
E	Glow plug	
F1	Fuse 24V 10A/12V 15A	Flat fuse SAE J 1284
H1	LED, green (in item S1)	Indicator
H6	Light (at least 1.2 W)	Switch-on indicator pumping device
H7	LED red (in item P)	Light in immediate heat button, ready indicator, ON indicator
H8	Heating symbol in the display (in item P)	On indicator, overheating indicator
H9	Light (in item P)	Display light
M	Motor	
P1	Combination timer (1531)	
P2	Standard timer (1531)	
S1	Control element	Setpoint generator switch
S2	1 or 2-pin disconnecting switch	Emergency Stop switch, electric or pneumatic
S3	Momentary-contact switch	Immediate heat button remote control
S4	Switch	On and for pumping device I
S5	Switch	On and for pumping device II
X1-X5	Plug connector, 2-pin	to item A2
X6	Plug connector, 8-pin	to item A2
X7	Plug connector, 4-pin	to item S1

Item	Description	Comment
X8	Plug connector, 2-pin	
X9	Plug connector, 2-pin	to item A2
X11	Plug connector, 6-pin	to item A2
X12	1-pin plug connection	Diagnostic (K cable)
X13	12-pin plug connection	to item P
Y1	Dosing pump	
Y2	Solenoid valve	for pumping device I
Y3	Solenoid valve	for pumping device II

14 Starting the heater for the first time

NOTE:

Refer to the safety instructions in the operating and maintenance instructions.

Read the operating and maintenance instructions before starting the heater.

After you have installed the heater, bleed the fuel supply system carefully.

NOTE:

As a result of the low fuel consumption the heater must be switched on several times to fill the fuel line.

Conduct a trial of the heater to check all the connections for leaks and to ensure that they are secure. If the heater suffers a fault during operation, the fault must be located and remedied.

15 Fault lock-out

The control unit has identified errors on individual heater components and faults during the starting procedure.

The heater is shut down (fault lock-out) if:

- Flame monitor resistance illegal
- Temperature sensor resistance too low
- Glow plug / actuation defective
- Blower speed too low or short circuit or break
- Error in the metering pump or overheating guard circuit (start phase only)
- Undervoltage less than 10 V or overvoltage greater than 15 V and for longer than 20 seconds (on 12 V heater)
- Undervoltage less than 20 V or overvoltage greater than 30 V and for longer than 20 seconds (on 24 V heater)
- Control unit defective

In the event of overheating no fuel will be supplied. A shut-down process will be carried out as if the heater had been shut down manually.

After it stops the control unit will be set to fault lock-out.

The overheating is indicated by the indicator flashing. Rectify the cause of the fault.

To reset the fault switch the heater off briefly (at least 2 seconds) and then on again.

15.1. Error code output

NOTE:

The error code is output if the heater is fitted with a control element after an error has occurred by the switch-on indicator/error code indicator flashing. After 5 seconds of fast flashing, the error code will be output by a sequence of long flash pulses, the number of flashes is shown in the table below.

If the heater is fitted with a combination timer, an error message will appear on the display of the timer after a fault occurs. If the control element is used the error number is indicated by the indicator light flashing:

- | | |
|------|--|
| F 01 | No start (after 2 attempts to start) |
| F 02 | Flame failure (repeated >5) |
| F 03 | Undervoltage or overvoltage |
| F 04 | Premature flame recognition |
| F 05 | Flame monitor interrupt or flame sensor short-circuit |
| F 06 | Temperature sensor interrupt or temperature sensor short-circuit |
| F 07 | Metering pump interrupt or metering pump short circuit |
| F 08 | Fan motor interrupt or fan motor short circuit or blower motor incorrect speed |
| F 09 | Glow plug interrupt or glow plug short circuit |
| F 10 | Overheating |

Technical data

16 Technical data

Except where limit values are specified, the technical data refer to the usual heater tolerances of $\pm 10\%$ at an ambient temperature of $+20^{\circ}\text{C}$ and at the rated voltage and in rated conditions.

16.1. Electrical components:

Control unit, motor, metering pump, lamp in the timer* and glow plug are designed for either 12V or 24V.

The timer*, temperature limiter and flame sensor components are not dependent on voltage.

* No timer for ADR mode

16.2. Fuel for Air Top 2000 B (petrol):

The fuel specified by the manufacturer must be used.

16.3. Fuel for Air Top 2000 D (diesel/EL heating oil):

The diesel fuel specified by the manufacturer must be used. Class EL heating oil (not L heating oil) may also be used as long as it complies to the normal quality available on the German market pursuant to DIN 51603.

We know of no negative influences due to additives.

If fuel is extracted from the vehicle's tank, follow the additive instructions issued by the vehicle manufacturer.

If you change to low-temperature fuel, the heater must be operated for approx. 15 minutes so that the fuel system is filled with the new fuel.

Do not add waste oil to the fuel.

Heater	Operation	Air Top 2000 B	Air Top 2000 D
EC licensing symbol		e1*72/245*95/54*1085*-- e1*2001/56*0013*--	
Model		Air heater with evaporator burner	
Heat output	Control range	1.1 - 2.0 kW	0.9 - 2.0 kW
Fuel		Petrol	Diesel
Fuel consumption	Control range	0.1 .. 0.2 kg/h (0.16 .. 0.27 l/h)	0.1 .. 0.21 kg/h (0.12 .. 0.24 l/h)
Rated voltage		12V	12 / 24V
Operating voltage range		10 - 15V	10 - 15 /20 - 30V
Rated power consumption	Control range	9 -22 W	
Max. ambient temperature:			
Heater	- Operation	-40... +40°C	
	- Storage	-40... +85°C	
Metering pump	- Operation	-40... +20°C	
	- Storage	-40... +85°C	
Control element	- Operation	-40... +75°C	
	- Storage	-40... +85°C	
Maximum combustion air inlet temperature		-40... +20°C	
Adjustment range for interior temperature	Control range	+10... +45°C	
Delivery rate of the hot air against 0.5 mbar	Max.	70 m ³ /h	
CO ₂ in the exhaust fumes (normal function range)	Max.	9.5 ... 10.5	9.5 ... 12.0
Heater dimensions		Length 322 ± 2 mm Width 130 ± 1 mm Height 122 ± 1 mm	
Weight		2.6 kg	

Drilling template

17 Drilling template

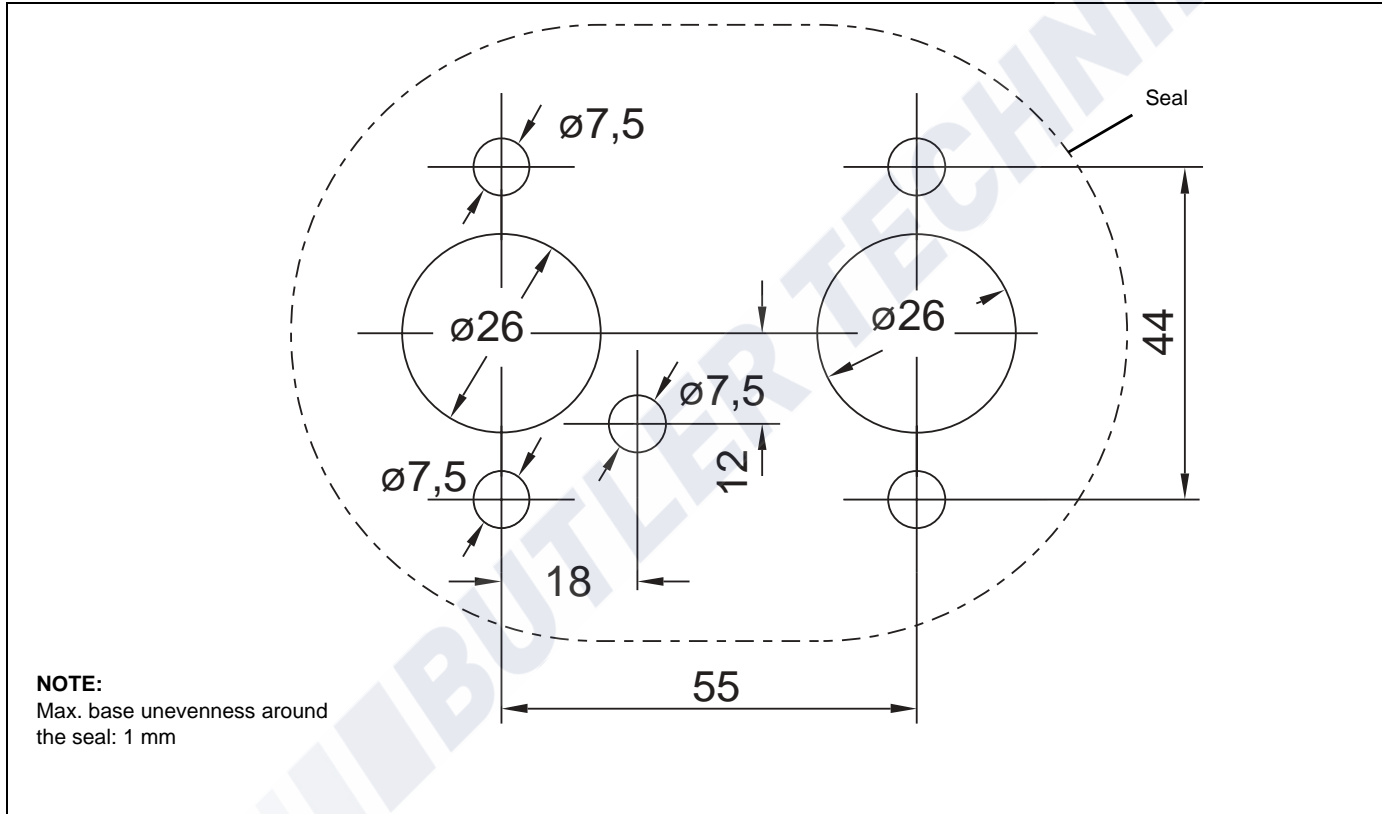

Fig. 37: Drilling template