



Air heaters B3LC / D3LC / B3LP / D3LP

Troubleshooting and Repair Instructions

Eberspächer®

J. Eberspächer
GmbH & Co.
Eberspächerstr. 24
D-73730 Esslingen

Telefon (zentral)
(0711) 939-00
Telefax
(0711) 939-0500
<http://www.eberspaecher.de>

The Troubleshooting and Repair Manual is valid for the following heater versions

B3L C

20 1717 05 00 00 - 12 Volt¹⁾

D3L C

25 1822 05 00 00 - 12 Volt¹⁾

25 1843 05 00 00 - 12 Volt²⁾

25 1867 05 00 00 - 12 Volt³⁾

25 1823 05 00 00 - 24 Volt²⁾

25 1844 05 00 00 - 24 Volt³⁾

B3L P

20 1734 05 00 00 - 12 Volt¹⁾

D3L P

25 1854 05 00 00 - 12 Volt¹⁾

25 1850 05 00 00 - 24 Volt²⁾

- ¹⁾ Without combustion-off control
- ²⁾ With combustion-off control and post-ventilation
- ³⁾ With combustion-off control, without post-ventilation

Contents

Page

First check the following if faults occur	2
Diagnosis test.....	3-5
Wiring diagrams	6,7
Repair instructions	8-13
Test equipment and adapters	14,15
Fuel quantity measurement	16

See spare parts list for available spare parts.

See the technical description/installation instructions/operating instructions included with every heater for description of operation.

First check the following if faults occur:

Fuel in the tank?

Fuses OK?

Electrical leads and connections OK?

Combustion air and exhaust piping free?

When combustion generates soot:

Combustion air pipe or exhaust pipe clogged? Clear obstruction

Metering pump conveying too much? Measure fuel quantity, replace metering pump

Deposits in heat exchanger, in exhaust pipe? Clean heat exchanger, exhaust pipe. Replace it if necessary.

Check values

Speed of blower motor - 1% + 3 %	B 3 LC / D 3 LC	B 3 LP / D 3 LP
• "High" setting:	3800 rpm / 4200 rpm ± 1 %	3200 rpm ± 1 %
• "Medium" setting:	2000 rpm ± 1 %	2000 rpm ± 1 %
• "Low" setting:	1800 rpm ± 1 %	1600 rpm ± 1 %
• Continued running:	3800 rpm ± 1 %	1600 rpm ± 1 %
• Continued ventilation (recirculated-air operation only):	1000 rpm ± 1 %	1000 rpm ± 1 %



Diagnosis test

The diagnosis test can be performed as follows:

Call diagnostic signals using operating device

1. Switch on heater using the operating device.
2. Connect a cable jumper between chamber 8/2 (1 ge) and chamber 8/3 (1 sw/ws) for 0.5 to 5 seconds at the 8-pin control elements plug of the "Heater" cable harness.

Using the diagnostic signal, determine the fault code in the following table, then ascertain the remedial action which corresponds to this fault code in the table on pages 4 and 5.

Perform diagnosis test using diagnostic unit

Insert the diagnostic unit and the necessary adapter cable between the cable harness and "Operating" cable.

The fault is then displayed on the diagnostic unit as a 3-digit number.

See pages 4 and 5 for a description of the fault code, fault description and remedial action.

Order No. for diagnostic unit 22 1512 89 00 00
 Order No. for adapter cable 22 1000 30 20 00

Important!

When connecting the diagnostic unit, follow the operating instructions.

0	Diagnostic signal	8 sec.	Fault code	Fault
	[Solid black bar]		000	No fault
	[Pulsed signal]		001; 002	Advance warning Overvoltage/undervoltage
	[Pulsed signal]		010	Overvoltage cutout
	[Pulsed signal]		011	Undervoltage cutout
	[Pulsed signal]		020	Glow plug interruption
	[Pulsed signal]		029 - 033 036	Burner motor/speed control defective
	[Pulsed signal]		052	Non-start Safety time exceeded
	[Pulsed signal]		023; 024	PCB current controller Interruption/short-circuit
	[Pulsed signal]		012; 013	Overheat/metering pump interruption Overtemperature of flame sensor
	[Pulsed signal]		047	Short-circuit in metering pump
	[Pulsed signal]		060 - 063	Temperature control sensor: interruption/short-circuit Setpoint potentiometer: interruption/short-circuit
	[Pulsed signal]		064; 065	Flame sensor interruption/short-circuit
	[Pulsed signal]		055; 056	Flame loss in "Medium" setting Flame loss in "Low" setting
	[Pulsed signal]		053; 054	Flame loss in "Power" setting Flame loss in "High" setting
	[Pulsed signal]		092 - 094	Control unit defective
	[Pulsed signal]		091	Fault caused by external interference voltage (reset)

Fault code	Fault description	Remarks/Remedial action
000	No fault	
001	Advance warning: overvoltage	Voltage between A3 and A4 greater than 14 V or 28 V at control unit. Voltage between A3 and A4 less than 11 V or 22 V at control unit (no advance warnings given with MB versions).
002	Advance warning: undervoltage	
010	Overvoltage cutout	Voltage between A3 and A4 greater than 14.7 V or 29.4 V at control unit. Voltage between A3 and A4 less than 10.5 V or 21 V at control unit (voltages must be present for longer than 20 seconds). Check battery, controller and power leads.
011	Undervoltage cutout	
012	Overheat or metering pump interruption (B12)	Check connection of control unit B12 up to metering pump for continuity. Check safety thermal cutout switch (switching value 160°C - 190°C). Check hot air lines for blockage. Clear blockage if necessary.
013	Overtemperature of flame sensor (B10)	Control unit interlock: flame sensor displays temperature of > 330°C at heat exchanger, ohmic value between B2 and B10 > 2220 Ω, Flame sensor values: 900 Ω at -25°C 1100 Ω at +25°C Check hot air lines for blockage. Clear blockage if necessary. Check functioning of safety thermal cutout switch.
020	Glow plug interruption (A1)	Check glow plug. Replace if necessary. Check connection of control unit A1 and glow plug up to connection of PCB (12/3) for continuity. Check connection of control unit A4 up to connection of PCB (12/6) for continuity. If OK, replace PCB.
023	Current controller PCB interruption (P5)	Check connection of control unit B5 to connection of PCB (12/5) for continuity. If OK, replace PCB.
024	Short-circuit in PCB current controller (B5)	Check connection of control unit B5 to connection of PCB (12/5) for short-circuit to supply +. If OK, replace PCB.
025	Short-circuit at diagnostic unit output (B4)	Check connection of control unit B4 to connection of diagnostic unit for short-circuit to +.
029	Burner motor or	Speed deviation longer than 30 seconds: • Speed < 40% of nominal value (motor does not turn) • Speed > 270% of nominal value (motor turns to limit) Measure voltage at 5-pin motor plug between 4/2 (gr) and 4/1 (vi) using analog voltmeter when blower is running. (Attention: this check <u>cannot</u> be carried out on 4-pole motor!) Sensor setpoint: 4 V (+/- 0.3 V), average value. If deviation is found, replace motor with integrated sensor. If sensor is OK, then speed controller is defective. Replace PCB.
030	Speed controller defective	
031	Speed deviation	
032		
033		
036	Short-circuit: speed setpoint signal (B6)	Check connection of control unit B6 to connection of PCB (12/2) for short-circuit to supply +. If OK, replace PCB.
047	Short-circuit in metering pump (B12)	Check connection of control unit B12 to metering pump for short-circuit. Check or replace metering pump if necessary.



Fault code	Fault description	Remarks/Remedial action
050	Too many start-up attempts	Control unit interlocks when switched on 5 times in succession (=10 start-up attempts) without flame detection (fault code 052).
052	Non-start - safety time exceeded	No flame detected during start-up phase. Flame sensor value < 100°C (1380 Ω). Check fuel supply and glow plug. Check exhaust gas and combustion air lines. Check flame sensor: Flame sensor values: 900 Ω at -25°C 1100 Ω at +25°C
053	Flame loss in "Power" setting	Heater has ignited (flame detected) and registers flame loss in a "Power" setting. Check fuel quantity, blower speed and fuel supply. Check exhaust-gas line and combustion air line. If combustion is OK, check flame sensor and replace it if necessary. Flame sensor values: 900 Ω at -25°C 1100 Ω at +25°C
054	Flame loss in "High" setting	
055	Flame loss in "Medium" setting	
056	Flame loss in "Low" setting	
060	Flame sensor interrupted (B3))	Flame sensor registers temperature value outside control range. Check the connecting lines. Ohmic value between B2 and B3 > 3000 Ω (in the event of an interruption). Ohmic value between B2 and B3 < 260 Ω (in the event of a short-circuit). Flame sensor values: 1750 Ω at +8°C 2000 Ω at +25°C 2200 Ω at +37°C
061	Short-circuit in flame sensor (B3)	
062	Setpoint potentiometer interrupted (B8)	Operating device potentiometer registers setpoint outside control range. Check the connecting lines. Ohmic value between B2 and B8 > 3000 Ω (in the event of an interruption). Ohmic value between B2 and B8 < 260 Ω (in the event of a short-circuit). Normal values: 1750 Ω - 2200 Ω
063	Short-circuit in setpoint potentiometer	
064	Flame sensor interrupted (B10)	Flame sensor registers temperature value outside measurement range. Ohmic value between B2 and B10 > 3200 Ω (in the event of an interruption). Ohmic value between B2 and B10 < 200 Ω (in the event of a short-circuit). Check the connecting lines. Flame sensor values: 900 Ω at -25°C 1100 Ω at +25°C
065	Short-circuit in flame sensor (B10)	
091	Fault caused by external interference voltage (reset)	Control unit fault caused by interference voltages from vehicle electrical system. Possible causes: Poor batteries, chargers, other sources of interference Eliminate interference voltages.
090	Control unit defective (internal fault/reset)	Internal fault in microprocessor/memory detected. Replace control unit
092	Control unit defective (ROM fault)	
093	Control unit defective (RAM fault)	
094	Control unit defective (EEPROM fault)	
255	Control unit fault memory erased	Fault memory has been overwritten by external interference voltages. Eliminate interference voltages.

Wiring diagram

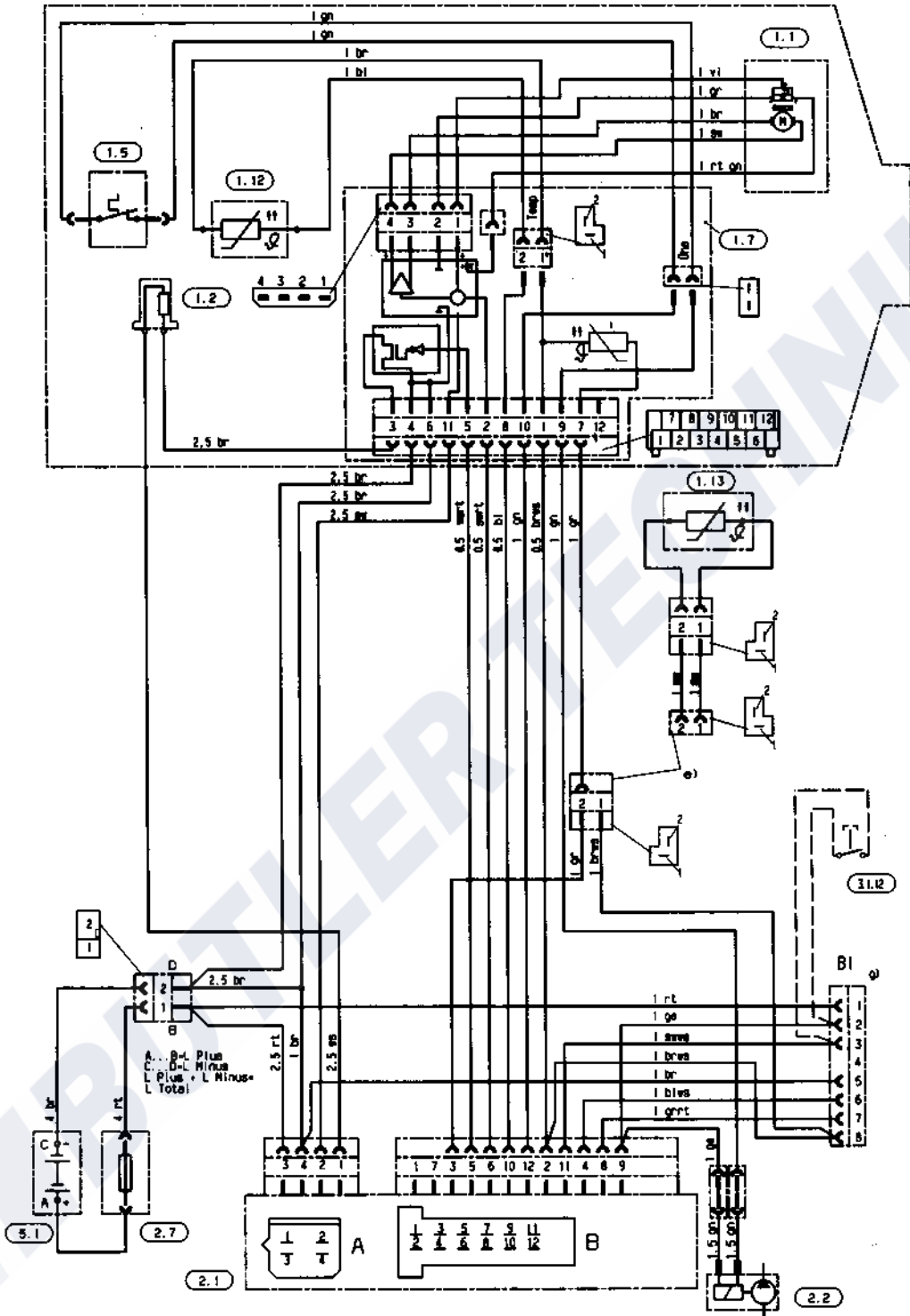

Parts List

25 1822 00 96 01 0C

- | | | | |
|------|---|--------|---|
| 1.1 | Burner motor | 2.1 | Control unit |
| 1.2 | Glow plug | 2.2 | Fuel metering pump |
| 1.5 | Safety thermal cutout switch | 2.7 | Main fuse (25 A) |
| 1.7 | PCB with control temperature sensor,
speed changeover and multiple connector | 3.1.12 | Fault code enquiry |
| 1.12 | Flame sensor | 5.1 | Battery |
| 1.13 | Flame sensor (external) | e) | When connecting flame sensor (external), detach
existing socket housing and attach socket housing
of flame sensor |
| | | g) | Connection of control elements to heater |



Wiring diagram

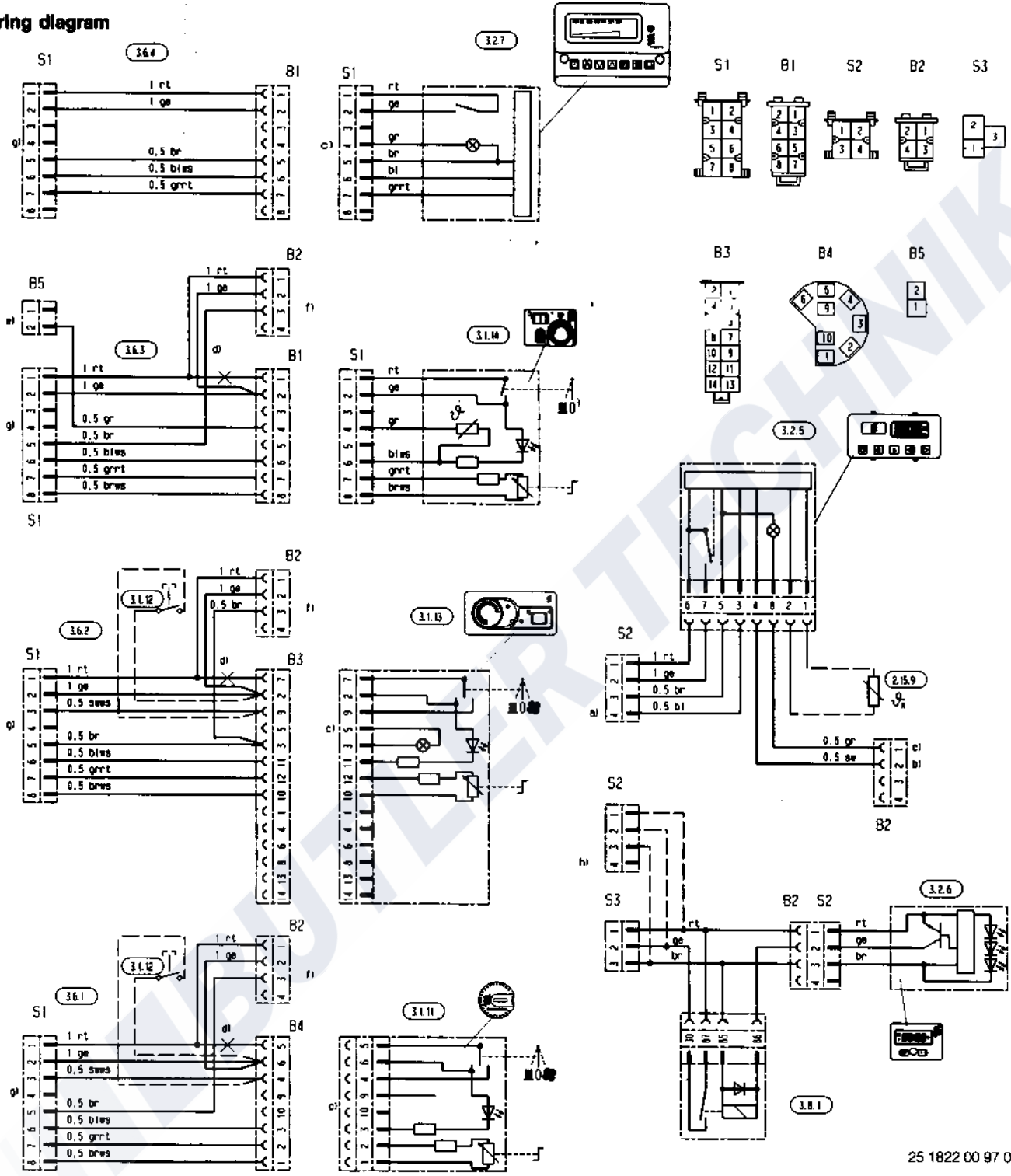

25 1822 00 97 01 C

Parts List

- 2.15.9 Sensor, external temperature
- 3.1.11 Operating unit
- 3.1.12 Fault code enquiry (garage)
- 3.1.13 Operating unit
- 3.1.14 Operating unit
- 3.2.5 Timer
- 3.2.6 Timer
- 3.2.7 Timer

- 3.6.1 Cable harness for 3.1.11
- 3.6.2 Cable harness for 3.1.13
- 3.6.3 Cable harness for 3.1.14
- 3.6.4 Cable harness for 3.2.7
- 3.8.1 Timer relay

- a) Test (garage) digital timer
- b) to terminal 15
- c) lighting terminal 58
- d) break line here to connector timer
- f) 3.2.5 / 3.2.6 / 3.2.7 to be connected here
- g) Connection control elements to heater
- h) Remove S 3 and fit S 2

Repair Instructions

Spare parts (see spare parts list for Cat. No.)

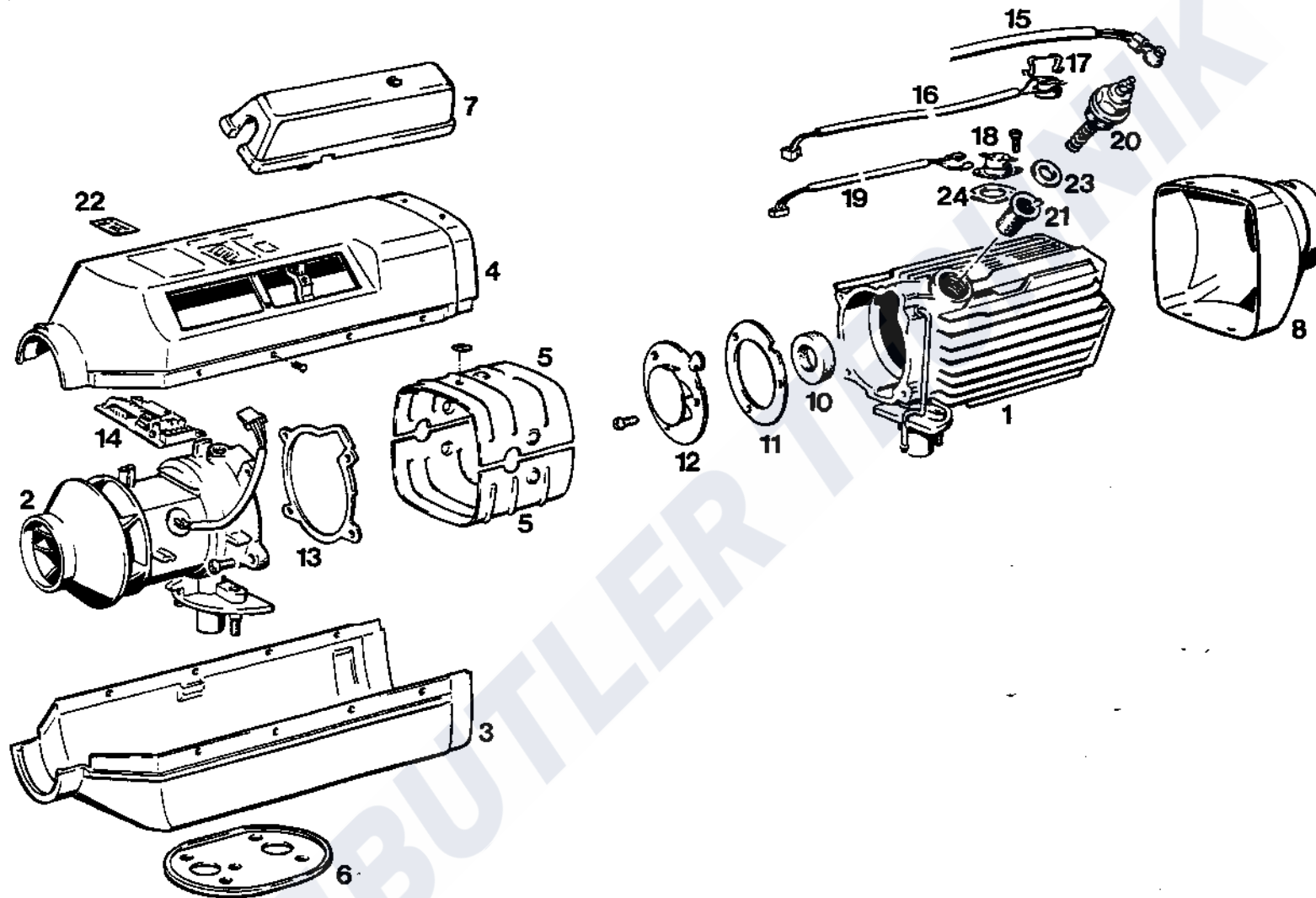

- 1 Heat exchanger
- 2 Combustion air blower
- 3 Lower casing half
- 4 Upper casing half
- 5 Heat protection plate

- 6 Sealing disc
- 7 Cap
- 8 Air outlet
- 10 Seal
- 11 Seal

- 12 Guide vane housing (not a spare part)
- 13 Flange seal
- 14 PCB
- 15 Cable for glow plug
- 16 Flame sensor with cable
- 17 Retaining spring

- 18 Safety thermal cutout switch
- 19 Cable for safety thermal cutout switch
- 20 Plug
- 21 Plug strainer
- 23 Glow plug seal
- 24 Insulating disk



Repair steps

1. Remove/install glow plug
2. Remove/install plug screen
3. Remove/install PCB
4. Detach air outlet
5. Detach/attach upper casing half
6. Remove/install safety thermal cutout switch
7. Remove/install flame sensor
8. Remove blower from heat exchanger, change seals on heat exchanger
9. Change seal on blower

1. Remove/install glow plug

Unscrew cap
 Detach glow plug connector
 Unscrew glow plug

Important!

When fitting the glow plug, always use a new seal.



2. Remove/install plug screen

Remove the plug screen from the plug connection using pliers.
 Clean off the plug vent using compressed air.
 When putting the plug screen back in ensure correct positioning of the lug and parting joint — see sketch.

Carefully slide in the plug screen as far as it will go.
 The hole for the plug vent (2 mm dia.) must then be free.



Installation position of plug screen in D 3 L C

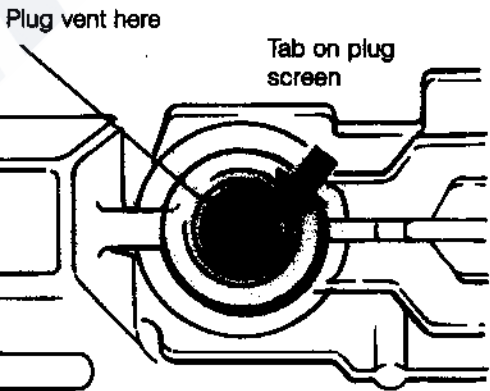

Installation position of plug screen in B 3 L C

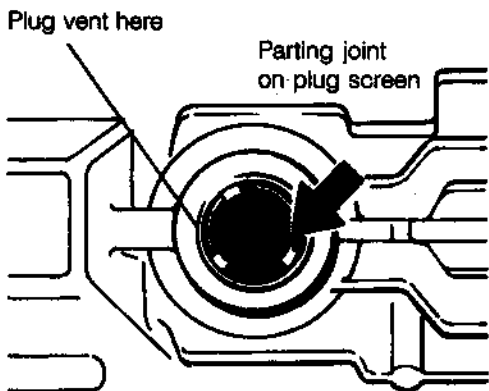

3. Remove/install PCB

Detach plug from PCB.
Press down the lug.
Pull out the PCB.

Caution: There is a risk of components being destroyed by electrostatic discharges when the PCB is touched.
Therefore only pick the PCB up by its outer edges!

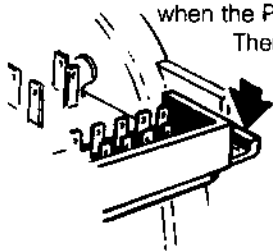

PCB with blower speed controller, electronic power switch and temperature sensor (internal).

After installation of the PCB, check whether the heater combustion process can be switched off in the "Low" setting. If necessary, accelerate this operation by returning hot air to the intake side.

Important: When connecting the 4-pin motor plug, plug it in to match its counterpart on the PCB.

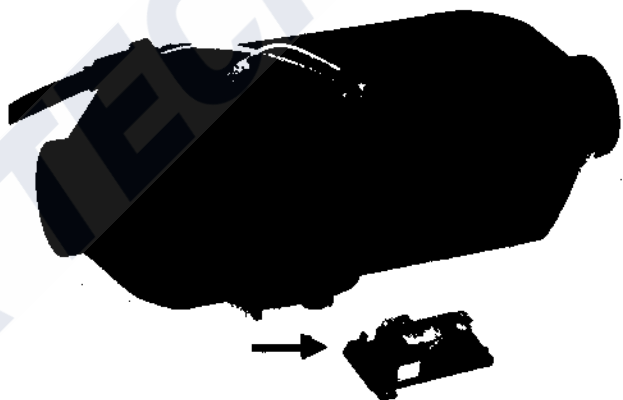

Flame sensor for heating air (internal) mounted on PCB

PCB

Connect individual plug here.

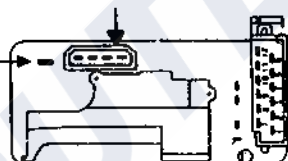

Important: The PCB must be kept inside its packaging bag until it is actually fitted.

4. Detach air outlet





5. Detach/attach upper casing half

To remove the body-bound rivet, knock the pin through with a small drift. Prise out the rivet with a knife.

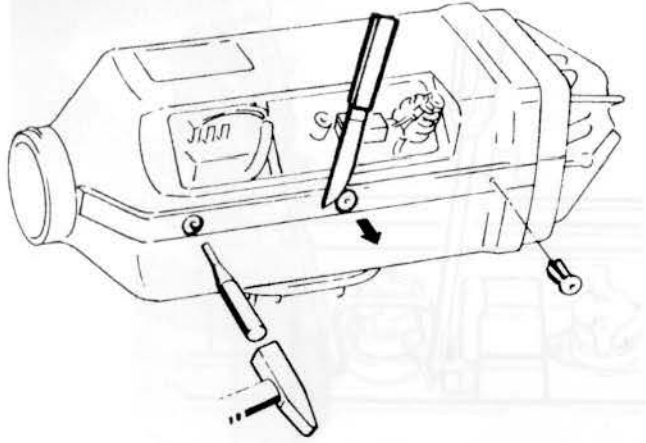

Use a new rivet for reassembly.

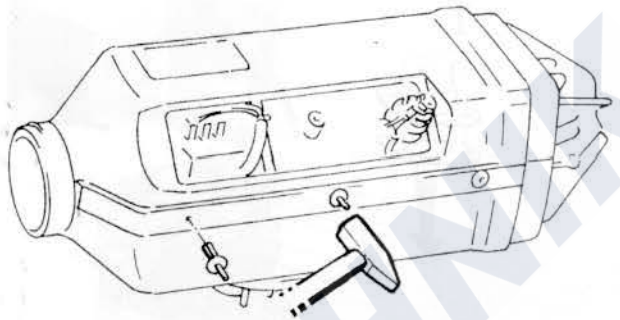

Remove the upper casing half.

During assembly, ensure that the cables are routed correctly.

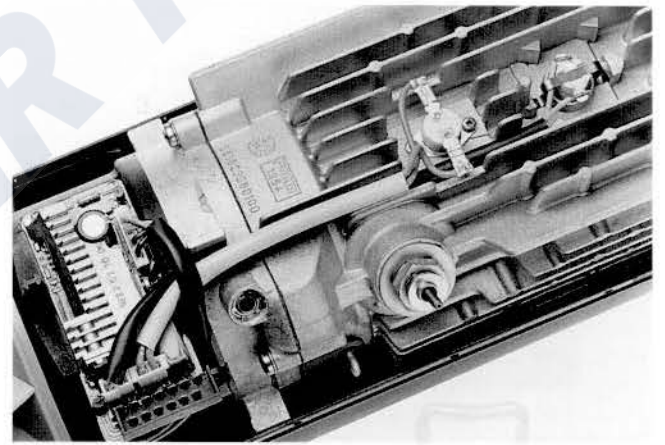
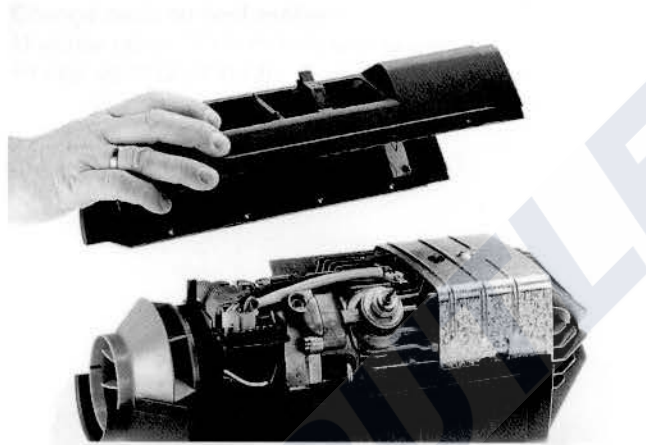

Take off the heat protection plate.

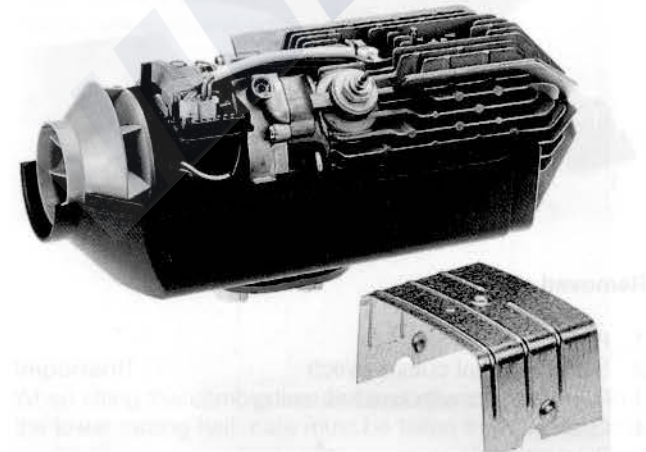

Use a new clamping spring for reassembly.

6. Remove/install safety thermal cutout switch

Insert insulating disk.
Use „Taptite“ screws.

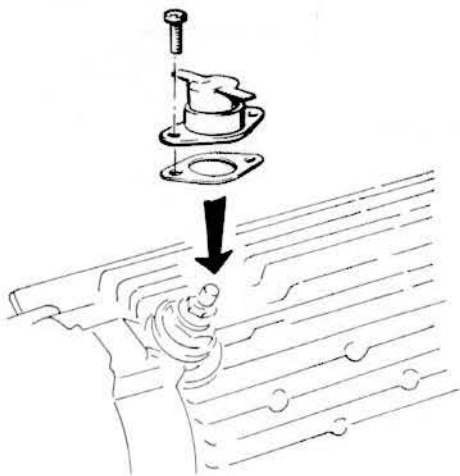

8. Remove flame sensor

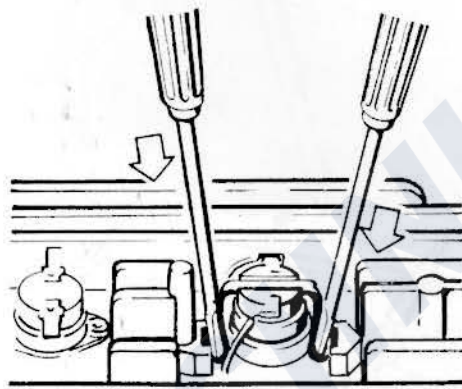

7. Install flame sensor

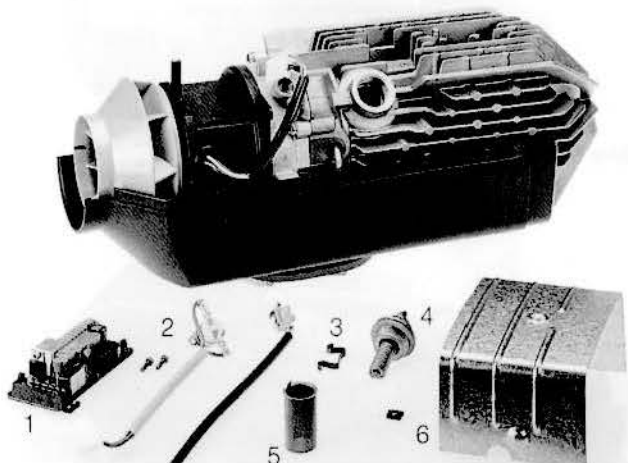

Removed parts

1. PCB
2. Safety thermal cutout switch
3. Flame sensor with bracket spring
4. Glow plug
5. Plug screen
6. Heat protection plate with double-clip



9. Remove blower from heat exchanger

Remove blower.

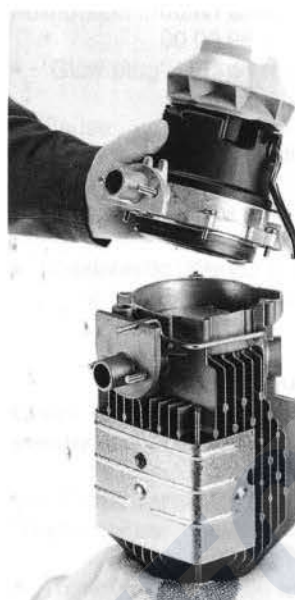

Change seals on heat exchanger.
Unscrew cover (1) from heat exchanger.
Fit new seals (2) and (3).

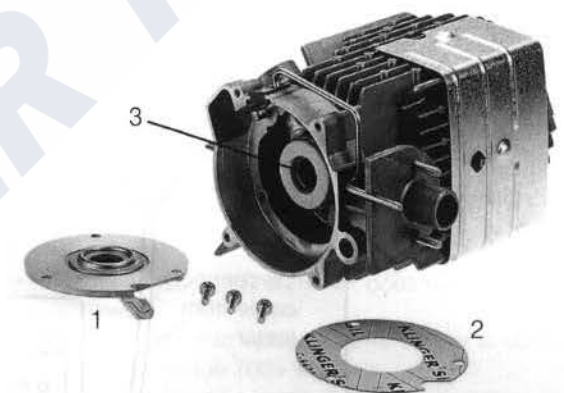

10. Change seals on blower

Detach/scrape old seal from blower housing.
Attach new seal (self-adhesive).

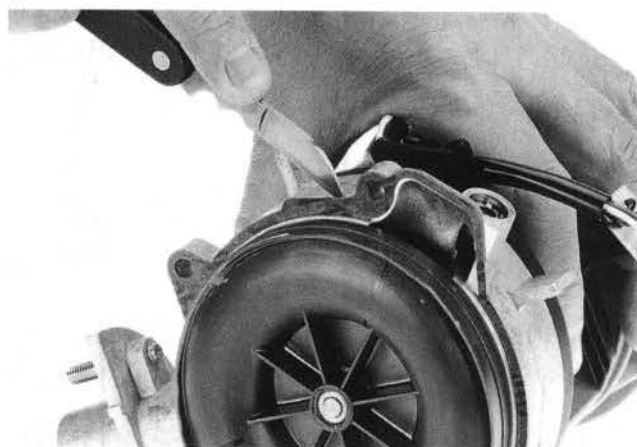

Important!

When fitting the combustion air blower/heat exchanger in the lower casing half, care must be taken that the supports for the blower are seated in the recesses of the lower casing half, otherwise the blower wheel might catch.

After fitting, measure the current input of the heater in the "Ventilation" setting, and check that the heater combustion process can be switched off in the "Low" setting.
12 V heater I = max. 3.0 A
24 V heater I = max. 1.5 A

Tester and test adapter

Cat. No. of tester 22 1509 89 00 00
Cat. No. of test adapter 22 1518 89 00 00

Prior to test

Connect the correct operating voltage (12 V or 24 V) to the two connecting sockets.

Connect + to red socket and - to blue socket.

Important!

Ensure that the operating voltage is correct, otherwise the connected components may become irreparably damaged.

Connect test adapter to tester and PCB

Disconnect cable from tester (PCB connection).

Connect test adapter cable to tester (PCB connection).

Remove cap from heater.

Disconnect 12-pin plug from PCB.

Connect test adapter cable to PCB.

Check operating device

Cat. No. of 12 V operating device 25 1767 71 00 00

Cat. No. of 24 V operating device 25 1768 71 00 00

- Disconnect plug of operating device from cable harness and connect to tester.
- Set rotary knob of operating device to "Ventilation" setting and then to "Heating" setting. The appropriate red LEDs on the tester must come on.
- Set operating device to "0" position. Press "LED - red" pushbutton. The red pilot light on the control unit must come on.
- Set operating device to "Heating" or "Ventilation" setting. Press the "LED - green" pushbutton. The appropriate red pilot light on the control unit and the green pilot light on the operating device must come on.

Check setpoint potentiometer of operating device

Set the "Temp. sensor/potentiometer" switch on the tester to the "Potentiometer" setting and slowly turn the rotary knob of the operating device as far as it will go.

The green "Temp. sensor/potentiometer" LED must remain lit without interruption.

In the event of a fault. Replace the operating device.

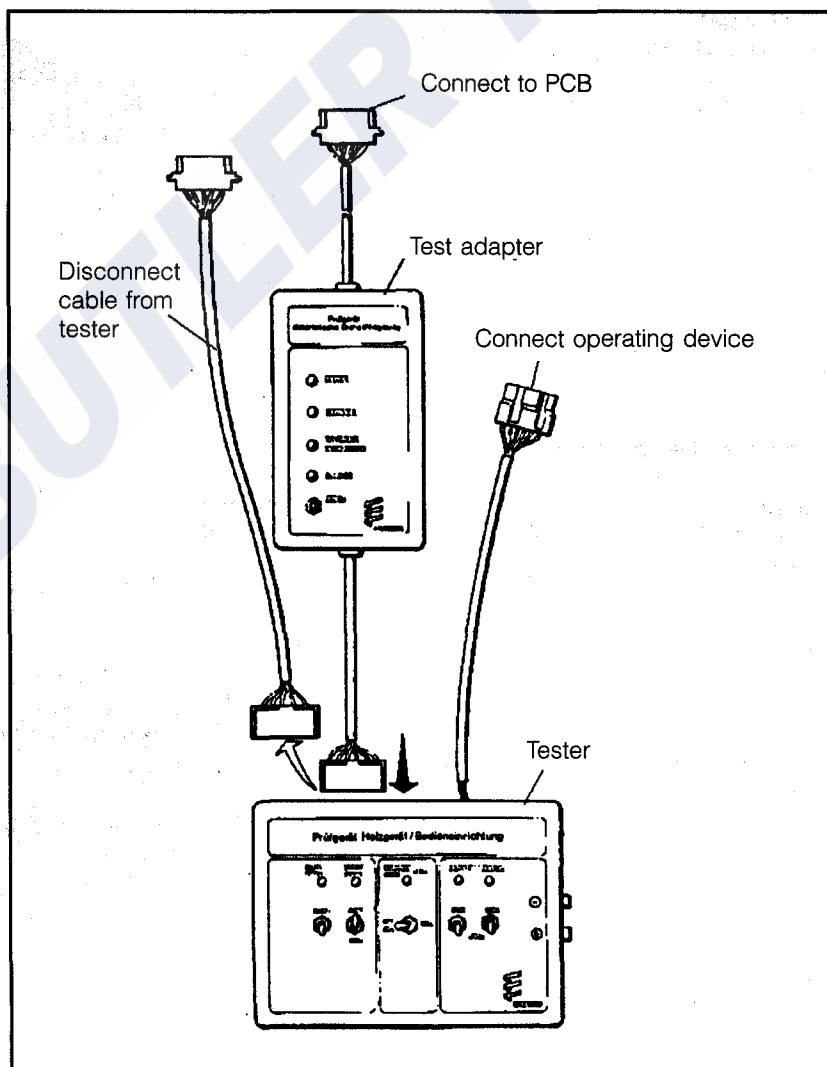



Check blower motor, speed control and PCB

3 blower speeds can be checked using the "Blower speed - off-control/medium" switch and the "Blower speed - high" pushbutton.

Nominal blower speed ($\pm 10\%$)

- in "Off-control" setting: Speed 1000 rpm
- in "Medium" setting: Speed 2000 rpm
- in "High" setting: Speed 3800 rpm/4200 rpm (right-hand switch of tester must be in the "Medium" setting)

If the nominal values specified above are achieved, the blower motor and speed control are OK.

If nominal values are not achieved:

- Motor runs at max. speed (5000 rpm) immediately
Speed LED in test adapter does not come on
Voltage LED in test adapter comes on

Cause: Speed sensor defective
Connecting lines broken

Remedy: Replace blower motor with integrated speed sensor
- Motor does not turn
Disconnect 4-pin plug from motor and connect supply voltage to chambers 3 + 4 (brown and black).
 - If motor turns Replace PCB
 - If motor does not turn Replace motor
- "Voltage" LED in test adapter does not come on

Cause: PCB defective

Remedy: Replace PCB
- "Watchdog" LED of glow plug line on test adapter does not come on

Cause: PCB defective

Remedy: Replace PCB

Check glow plug control

Pushbutton in "ON" setting

- "Glow plug" LED on test adapter does not come on

Cause: PCB defective

Remedy: Replace PCB
- "Glow plug" LED comes on and "Voltage" LED goes off

PCB OK

Check safety thermal cutout switch, flame sensor, flame sensor and PCB.

Set "Flame sensor/potentiometer" switch on tester to "Flame sensor".

- Three green LEDs on tester come on, the connected sensors are OK.
- "Safety thermal cutout switch" LED on tester does not come on

Cause: Safety thermal cutout switch defective
PCB defective
Connecting lead broken

Remedy: Check parts. Replace if necessary
- "Flame sensor" LED on tester does not come on

Cause: Ohmic value of flame sensor is outside range 700 - 4000 Ω .
Flame sensor defective
Connecting lead broken
PCB defective

Remedy: Check parts. Replace if necessary
- "Flame sensor" LED on tester does not come on

Cause: Ohmic value of temperature sensor is outside range 1600 - 2400 Ω .
Temperature sensor defective
Connecting lead broken
PCB defective

Remedy: Check parts. Replace if necessary

Fuel quantity measurement

CAUTION! Only measure the fuel when the battery is sufficiently charged. At least 11/22 V and max. 13/26 V as appropriate must be applied to the control unit during measurement. Initially, the temperatures at the fuel system during the measurement should be less than + 20° C.

1. Preparation

Detach the fuel line from the heater and place it in a measuring glass (15 cc. capacity).
 Connect a voltmeter to the 4-pin plug, terminal 3 (+) and 4 (-) of the control unit.
 Undo the nut on the plug connection, and switch on the heater.
 After the blower has started, detach the plug cable. After about 45 seconds, the metering pump starts to pump fuel. When the fuel is coming out smoothly and free of bubbles, the fuel line is filled and blew
 Switch off the heater and empty the measuring glass.

2. Measurement

Reattach the plug cable.
 Switch on the heater.
 After the blower has started, detach the plug cable.
 Fuel pumping starts about 45 seconds after switch-on.
 Keep the measuring glass at the level of the plug during measurement.
 Read off the voltage at the voltmeter.
 After about 90 seconds, fuel pumping is switched off automatically.
 Switch off the heater, otherwise the start is repeated.
 Measure the fuel quantity in the measuring glass.

3. Evaluation

Plot the readings onto the diagram.
 Fuel consumption is OK when the intersection of the two values is inside the limit curve.
 If they intersect outside this curve, the fuel metering pump must be replaced.

