



Air heaters B5L/D5L / B5LC/D5LC

Troubleshooting and repair manual

J. Eberspächer
GmbH & Co.
Eberspächerstr. 24
D-73730 Esslingen

Telefon (zentral)
(0711) 939-00
Telefax
(0711) 939-0500
<http://www.eberspaecher.de>

The Troubleshooting and Repair Manual is valid
for the following heaters:

B5L

20 1707 05 00 00 – 12 Volt
20 1708 05 00 00 – 24 Volt

B5LC

20 1735 05 00 00 – 12 Volt
20 1736 05 00 00 – 24 Volt

D5L

25 1729 05 00 00 – 12 Volt
25 1730 05 00 00 – 24 Volt

D5LC

25 1861 05 00 00 – 12 Volt
25 1862 05 00 00 – 24 Volt

Contents	Page
Sectional view.....	2
Description of operation.....	3
In the event of faults, first check the following points.....	4
Function and fault test.....	4, 5
Wiring diagrams.....	6, 7
Repair instructions.....	8 – 13
Measuring the fuel quantity.....	14
Using the test adapter.....	15, 16

Sectional drawing D5L/D5LC

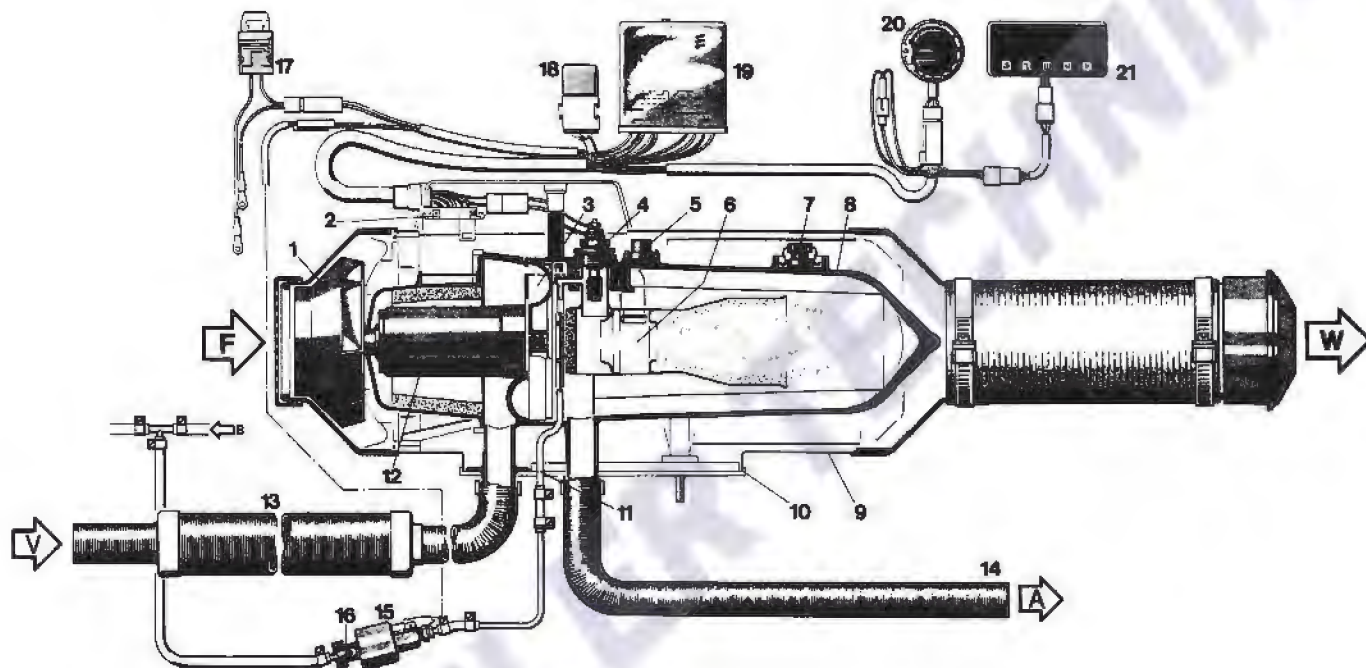

Parts list

- | | |
|---------------------------------------|-----------------------------------|
| 1 Heating air blower wheel | 12 Blower motor |
| 2 PCB with temperature control sensor | 13 Combustion air intake silencer |
| 3 Combustion air blower wheel | 14 Exhaust line |
| 4 Glow plug | 15 Fuel metering pump |
| 5 Safety thermal cutout switch | 16 Fuel filter |
| 6 Combustion chamber | 17 Main fuse, 25 A |
| 7 Flame sensor | 18 Glow plug relay |
| 8 Heat exchanger | 19 Control unit |
| 9 Outer casing | 20 Actuating unit |
| 10 Flange seal | 21 Heating timer |
| 11 Fuel line | |

- F = Fresh air
V = Combustion air
B = Fuel
W = Hot air
A = Exhaust



Description of operation

Mode of operation

Sequence after switch-on

Switch-on: green pilot light in the operating unit "ON".

After about 1 second: heating coil of glow plug "ON".

Blower "ON" at full speed.

After 33 – 70 seconds: fuel pump "ON".

Once a stable flame has been obtained, the glow plug is switched off.

To reach the operating temperature of the heat exchanger quickly, the heater is operated at an increased heating capacity of 5.5 kW after being switched on.

Once the heat exchanger operating temperature has been reached, the heating capacity is reduced to 4.8 kW.

The duration of heater operation with increased capacity depends on the ambient temperature.

Regulation in heating operation

Once the intake/room temperature as set at the operating unit has been reached, the heater switches to the "LOW" setting and then continues to run at low blower motor speed.

If the heating capacity in the "LOW" control setting is insufficient, the heater switches to the "MEDIUM" setting.

The blower continues to operate at low speed.

In most cases, the LOW/MEDIUM/LOW settings at low speed will provide the required heat.

If the heating capacity in the "MEDIUM" setting is insufficient, the heater switches back to the "HIGH" setting. This entails full speed for the blower motor again.

If in some cases even less heating capacity is needed than the heater supplies in the "LOW" setting, the heater switches to the "OFF" setting.

The heater continues to run after shutdown, followed by constant after-ventilation prior to restart.

The constant after-ventilation applies only for heaters in recirculated air mode.

The subsequent restart is in the "MEDIUM" setting at low blower motor speed.

When the heater is finally switched off, the green pilot light goes out and the blower continues to run until it cools down. During continued operation, the glow plug is switched on for approx. 30 secs. to clean it of combustion residues.

This continued operation will always end after about 4 to 5 minutes at low speed.

Control and safety equipment

The flame is monitored by the flame sensor (7), the maximum permitted temperature by the safety thermal cutout switch (5).

Both of them affect the control unit (19), which switches off the heater in the event of faults.

1. If the heater does not ignite within 90 seconds of the start of fuel pumping, starting is repeated as described. If the heater still does not ignite after a further 90 seconds, fault shutdown follows.
2. If the flame goes out by itself during operation, a restart follows first. If the heater does not ignite within 90 seconds of fuel pumping being switched on, or it does ignite but then goes out within 10 minutes, fault shutdown follows. The fault shutdown can be cancelled out by briefly switching the heater off and back on again.
3. In the event of overheating, the safety thermal cutout switch (5) reacts, the fuel supply is interrupted, and fault shutdown follows. If overheating is the cause of a fault shutdown, the switch-on pilot light (green) in the operating unit flashes steadily. Once the cause of the overheat has been remedied, the heater can be restarted by switching it off and then back on again.
4. Further fault indicating signals can be obtained with additional equipment, and are described in the troubleshooting and repair instructions on pages 4 and 5.
5. If the voltage drops below about 10.5 or 21 V, or rises above 15 or 30 V as the case may be, fault shutdown follows.
6. If the glow plug is defective and the electric line to the metering pump has a break, the heater will not start.
7. When the heater is started the functioning of the blower motor is checked once. If it does not start, the heater will undergo fault shutdown. During operation, the blower motor is monitored in cycles (4 mins.). If the motor speed is below the permitted limit, fault shutdown follows.

Please note:

For electric welding work on the vehicle, the positive terminal of the battery must be disconnected and earthed in order to protect the control unit.

In the event of trouble, first check the following:

- Fuel in the tank?
- Fuses OK?
- Electrical lines and connections OK?
- Combustion air and exhaust piping systems free?

When combustion produces soot, check the following:

Combustion air and exhaust piping systems clogged? Remove cause of clogging.

Fuel metering pump conveying too much? Measure fuel quantity, replacing fuel metering pump if necessary.

Deposits in the heat exchanger? Clean heat exchanger, or replace it if necessary.

Function and fault test

Calling of diagnostic signals

Connect a switch to terminals 4 and 6 of the operating unit.

Turn on the switch and compare the diagnostic signal displayed by the operating unit with the list on page 5. Deal with the trouble as described under "Remedy".

Check values

Speed of blower motor

in HIGH setting: 5000 rpm \pm 10 %

in MEDIUM and LOW settings: 3000 rpm \pm 10 %

in continued operation: 3000 rpm \pm 10 %

in after ventilation: 850 rpm

(only in recirculated air mode)



Displayed by green LED	0 1 2 3 4 5 6 7 8 secs.	Remedy
Operation	████████████████████	—————
Warning of over-/undervoltage	███ ██████████	Check controller, charge battery
Overvoltage cutout	██████ ████	Check controller, if necessary test charger. Heater must be connected directly to the battery.
Undervoltage cutout	██████ ███	Charge battery, check controller.
Glow plug break	███ ███ ███	Check glow plug, glow plug series resistor (for B 5 L / D 5 L 24 V), replace. Check connecting lines and connection, check connection to glow plug relay.
Burner motor does not turn, speed changeover relay does not function	██████	Check motor speed (test adapter), if necessary replace blower. Check speed changeover (test adapter), if necessary replace PCB. Rated speed: high = 4500 ± 10 % rpm, medium/low = 3000 ± 10 % rpm
Short-circuit of glow-plug relay contacts	██ ██████████	Replace glow-plug relay
Safety time exceeded no start	██████ ████	Check fuel supply, test glow plug (interrupted coil, yet sooty connection), replace if necessary.
Overheat	████████████████████	Check heating air lines inlet and outlet for clogging, if necessary remove clog. Check electrical lines, contacts to metering pump. Check safety thermal cutout switch (test adapter).
Short circuit of fuel metering pump	███ ██████████	Check metering pump and supply lines, replace if necessary.
Temperature sensor defective	███ ██████████	Plug connection to temperature sensor in cable harness made internally/externally? Check PCB, internal temperature sensor (test adapter). If necessary test the external temperature sensor directly. Check connection to operating device, and check the latter (test equipment for operating device).
Flame sensor defective	███ ██████████	Check flame sensor or connection, and also PCB (test adapter).
Flame goes out at "Low" or "Medium" stage Heater goes out by itself	███	Check fuel quantity Check blower speed
Flame goes out at "High" stage Heater goes out by itself	███	Check fuel quantity Check blower speed
Control unit defective	██████ ██████████	Replace control unit
External disturbing voltages	██ ██████████	Remove cause
Erroneous flame recognition	██	Check flame sensor.

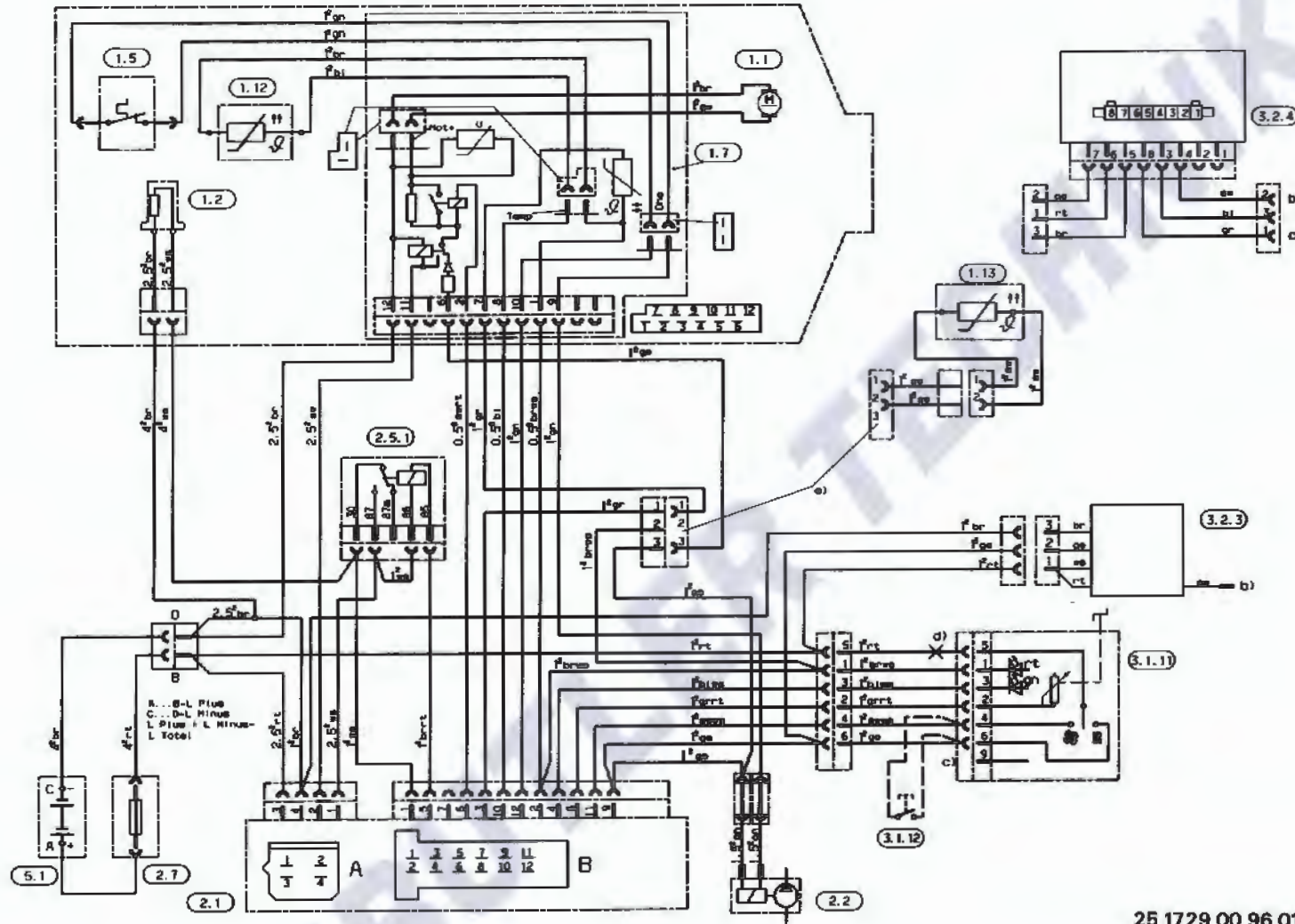

Wiring diagram - B5L/D5L - 12 Volt

25 1729 00 96 01 C

- | | | | |
|--|-------------------------|-----------------------------------|--|
| 1.1 Burner motor | 1.12 Flame sensor | 3.1.11 Actuating unit | a) test (workshop) digital timer |
| 1.2 Glow plug | 1.13 Temperature sensor | 3.1.12 Fault code enquiry | b) to terminal 15 |
| 1.5 Safety thermal cutout switch | 2.1 Control unit | 3.2.3 Timer, digital, square | c) lighting, terminal 58 |
| 1.7 PCB with temperature control sensor, speed change and multiple-blade connector | 2.2 Fuel metering pump | 3.2.4 Timer, digital, rectangular | d) if timer is connected, break line here |
| | 2.5.1 Glow plug relay | 5.1 Battery | e) if temperature sensor is connected, detach existing socket housing and fit socket housing of temperature sensor |
| | 2.7 Main fuse, 25 A | | |

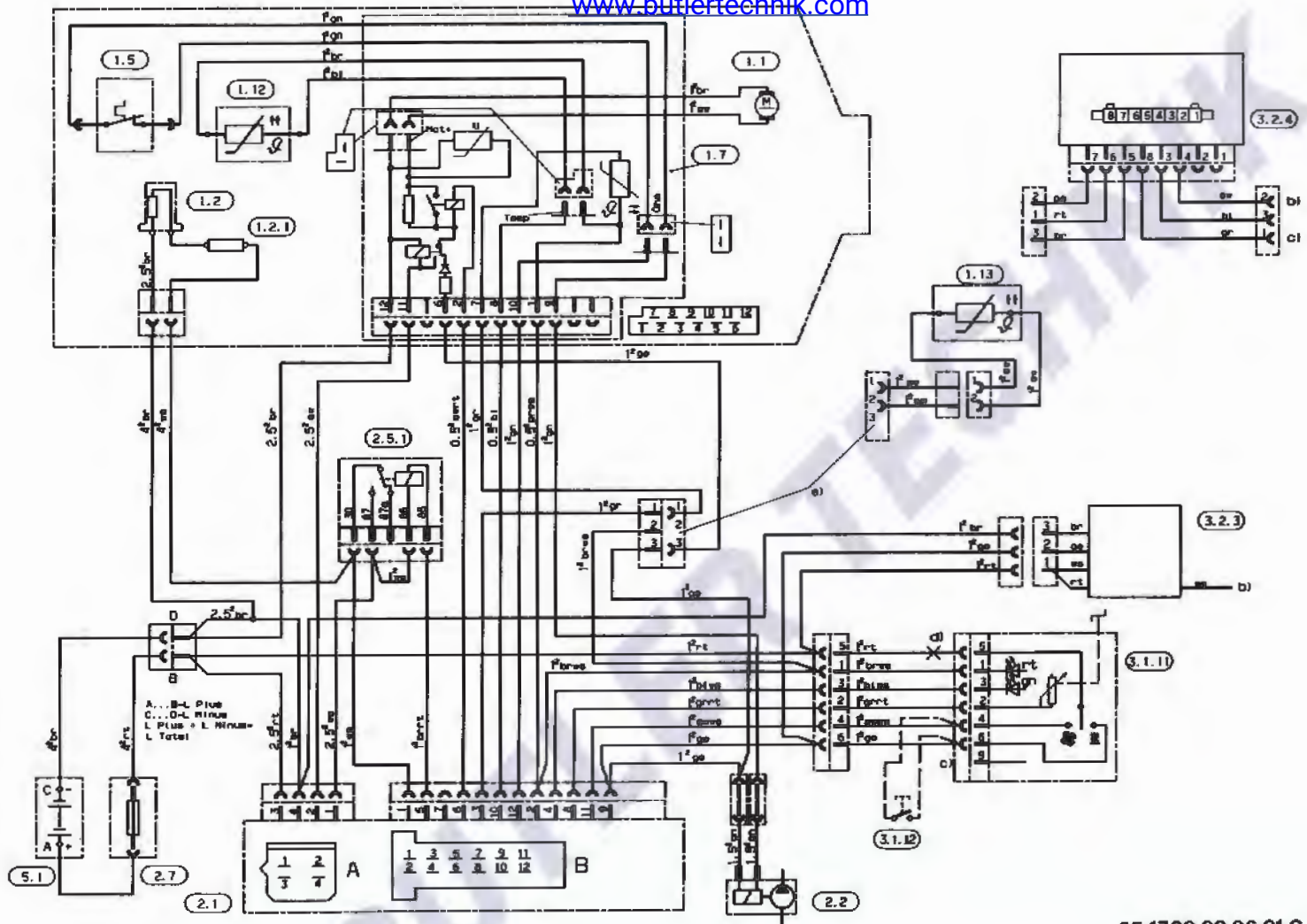

25 1730 00 96 01 C

- | | | | |
|--|-------------------------|-----------------------------------|--|
| 1.1 Burner motor | 1.12 Flame sensor | 3.1.11 Actuating unit | a) test (workshop) digital timer |
| 1.2 Glow plug | 1.13 Temperature sensor | 3.1.12 Fault code enquiry | b) to terminal 15 |
| 1.2.1 Glow plug resistor | 2.1 Control unit | 3.2.3 Timer, digital, square | c) lighting, terminal 58 |
| 1.5 Safety thermal cutout switch | 2.2 Fuel metering pump | 3.2.4 Timer, digital, rectangular | d) if timer is connected,
break line here |
| 1.7 PCB with temperature control sensor, speed change and multiple-blade connector | 2.5.1 Glow plug relay | 5.1 Battery | e) if temperature sensor is connected,
detach existing socket housing and fit
socket housing of temperature sensor |
| | 2.7 Main fuse, 25 A | | |



Repair Instructions

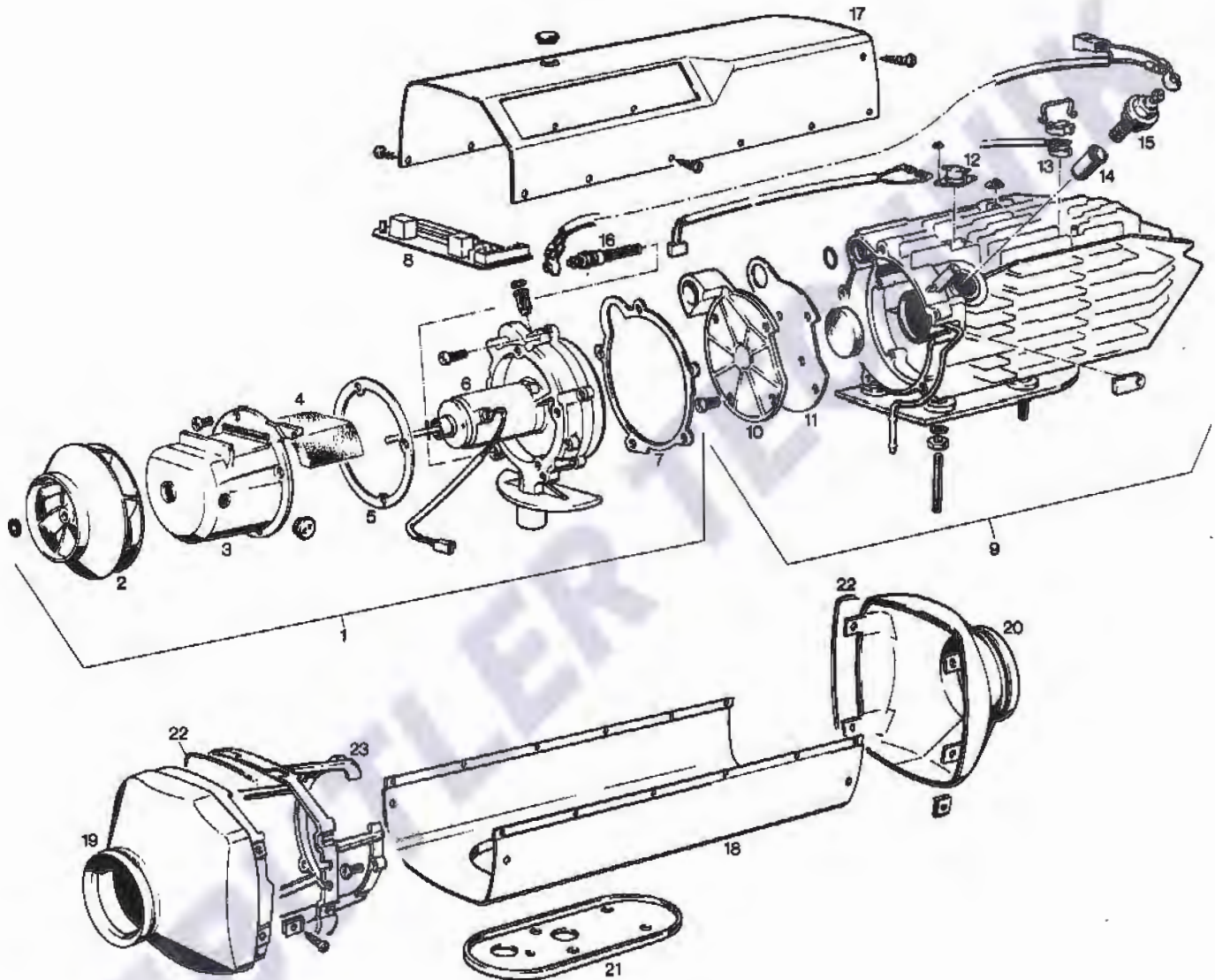

- 1 Combustion air blower
- 2 Blower wheel
- 3 Cover
- 4 Lining
- 5 Seal
- 6 Blower
- 7 Seal
- 8 PCB
- 9 Heat exchanger
- 10 Cover
- 11 Seal

- 12 Safety thermal cutout switch
- 13 Flame sensor
- 14 Plug strainer
- 15 Glow plug
- 16 Series resistor (for B5L/D5L 24 V only)
- 17 Upper casing half
- 18 Lower casing half
- 19 Intake end piece
- 20 Outlet end piece
- 21 Flange seal
- 22 Sealing
- 23 Carrier



Repair steps

1. Remove cable harness plus cap
2. Remove glow plug
3. Remove plug strainer
4. Remove PCB
5. Remove outlet end piece
6. Remove upper casing half and upper heat protection plate
7. Remove safety thermal cutout switch
8. Remove flame sensor
9. Remove series resistor for glow plug (B5 L/D5 L 24 V only)
10. Remove blower wheel
11. Remove cover from blower motor and fit new lining
12. Remove blower from heat exchanger
13. Remove cover from heat exchanger

1. Remove cable harness plus cap

Unscrew the cap from the heater and detach the plug connector from the PCB and glow plug.



2. Remove glow plug

Unscrew the glow plug connector.
Unscrew the glow plug.

When fitting a new glow plug, please note the following:

Check the plug strainer in the glow plug connection, clean it if necessary, or failing that replace it.



3. Remove plug strainer

Take the plug strainer out of the plug connection using pliers.
Clean the plug strainer, replace it if necessary.

Important! When fitting the plug strainer, ensure the nose is in the right position.
Slide in the plug strainer carefully as far as it will go.
The hole for plug area ventilation must then be free.

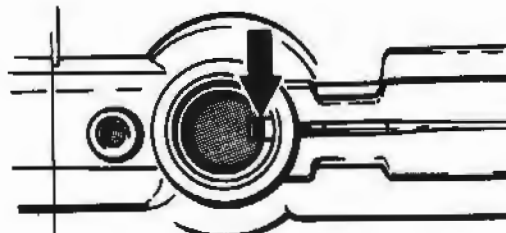

4. Remove PCB

Detach the plug connector from the PCB.
Press the PCB downwards and pull it out.

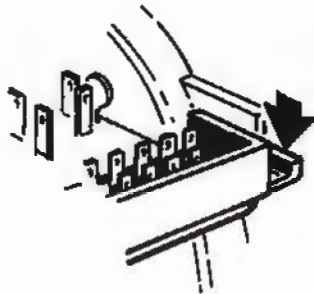

5. Remove outlet end piece

Unscrew the four fastening screws of the outlet end piece,
then remove the end piece.



6. Remove upper casing half and upper heat protection plate

Unscrew the fastening screws of the casing half, then
remove the casing half.
Remove both securing clips from the heat protection
plate.
Remove the heat protection plate.

Important: Use new securing clips when putting the heat
protection plate back in.





7. Remove safety thermal cutout switch

Detach the plug connector from the PCB.
Remove both securing clips from the safety thermal cutout switch.
Remove the safety thermal cutout switch.

Important! Use new securing clips when putting the safety thermal cutout switch back in.



Removing the safety thermal cutout switch

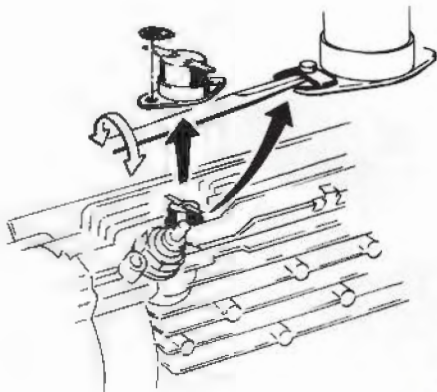

Fitting the safety thermal cutout switch

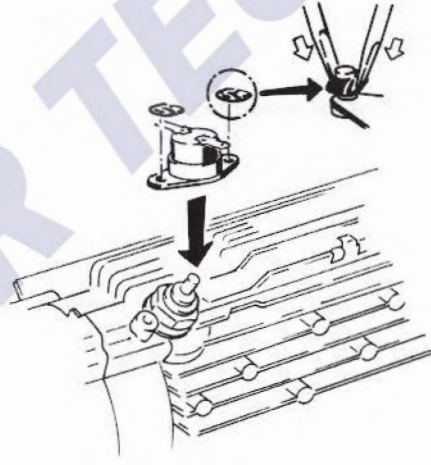

8. Remove flame sensor

Remove the retaining spring with a screwdriver.
Remove the flame sensor and the intermediate piece.

See also page 12.



Removing the flame sensor

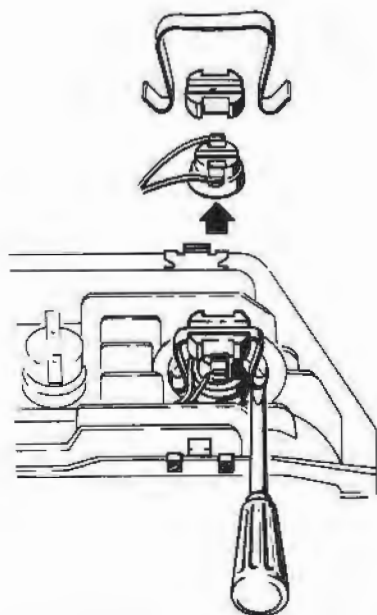

Fitting the flame sensor

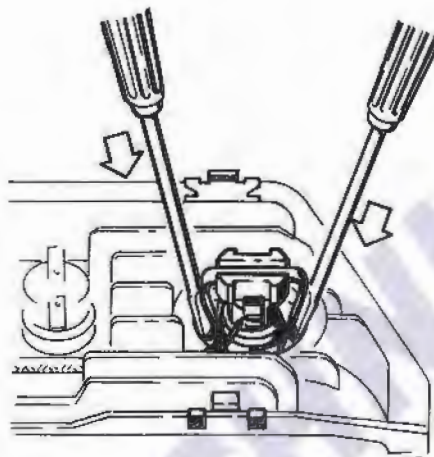

9. Remove series resistor for glow plug
(B5L/D5L 24 V only)

Note on removal:

The series resistor is fitted with a clamping ring, not a thread!

Unscrew the connection at the series resistor.
Remove the series resistor as shown in the figure.

Fitting the series resistor:
Drive the series resistor with an 18 x 1 diameter pipe into its mounting by light hammer blows.



10. Remove blower wheel

Remove the lock ring from the blower wheel using a screwdriver.
Pull the blower wheel off the shaft of the electric motor.





11. Remove cover from blower motor and fit new lining

Unscrew the fastening screws from the cap. Remove the cap, and fit a new lining if necessary.

Important! When fitting the cover, use only the original screws or new ones (Taplrite M5 x 12).

12. Remove blower from heat exchanger

Unscrew the fastening screws from the support. Remove the support from the blower.

Unscrew the fastening screws from the blower. Remove the blower and clear the heat exchanger and blower of sealing residues.

Important! When assembling the heat exchanger and blower, replace the seal.

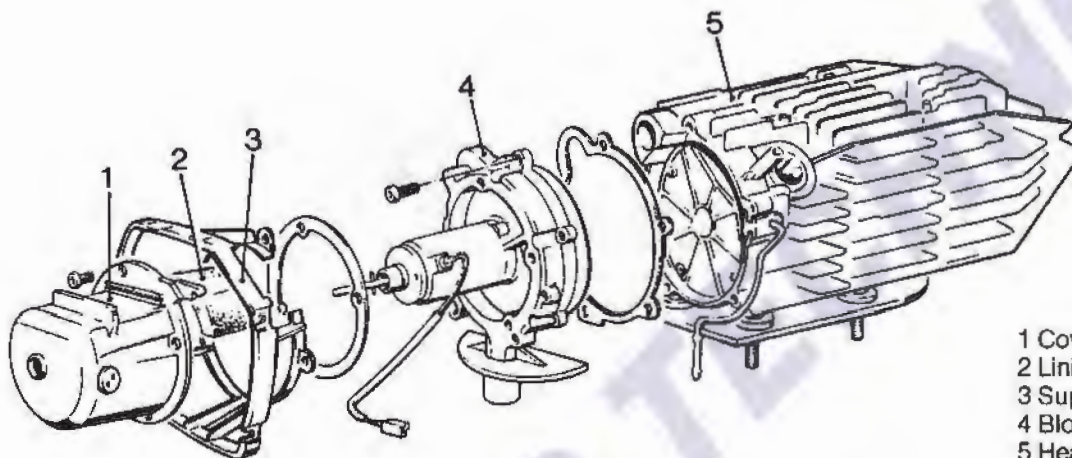

- 1 Cover
- 2 Lining
- 3 Support
- 4 Blower
- 5 Heat exchanger

13. Remove cover from heat exchanger

Unscrew the fastening screws from the cover. Lift the cover off the heat exchanger using an angled hook through the exhaust connection.

Important! Slide the pipe of the combustion air system into the cover.
When fitting the cover, use a new seal.
When fitting the cover, use only the original screws or new ones (Taplrite M5 x 12).

- 1 Heat exchanger
- 2 Cover
- 3 Pipe of combustion air system

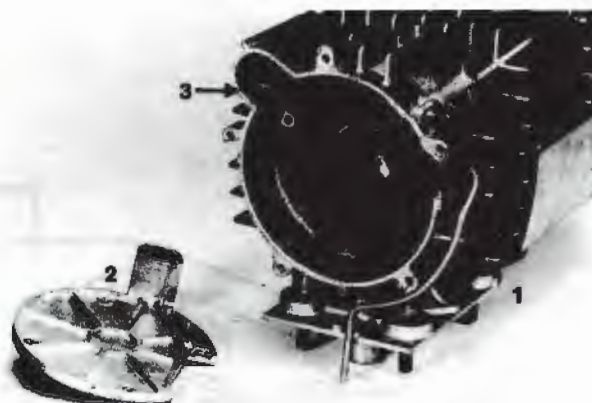

Measuring the fuel quantity

IMPORTANT! Only measure the fuel when the battery is sufficiently charged. At least 11/22 V or max. 13/26 V should be applied to the control unit during measurement.

1. Preparation

Detach the plug connector under the cover cap on the heater and connect a test lamp. Detach the fuel line from the heater and insert it into a measuring glass. Connect a voltmeter to the 4-pin plug, terminals 3 (+) and 4 (-), of the control unit. Switch on the heater; when fuel is being pumped steadily (around 25 – 55 secs. after switch-on), the fuel line is filled and free of air. Switch off the heater and empty the measuring glass.

2. Measurement

Switch on the heater. Fuel is pumped after about 25 – 55 secs. after switch-on. Hold the measuring glass at the level of the plug during measurement. Read off the voltage at the voltmeter. After 90 secs. of fuel pumping, this stops automatically. Switch off the heater. Read off the fuel quantity in the measuring glass.

3. Evaluation

Transpose the readings onto the graph. Fuel consumption is OK when the intersection of both values is within the limit curve. If the intersection is outside the curve, the fuel metering pump must be replaced.

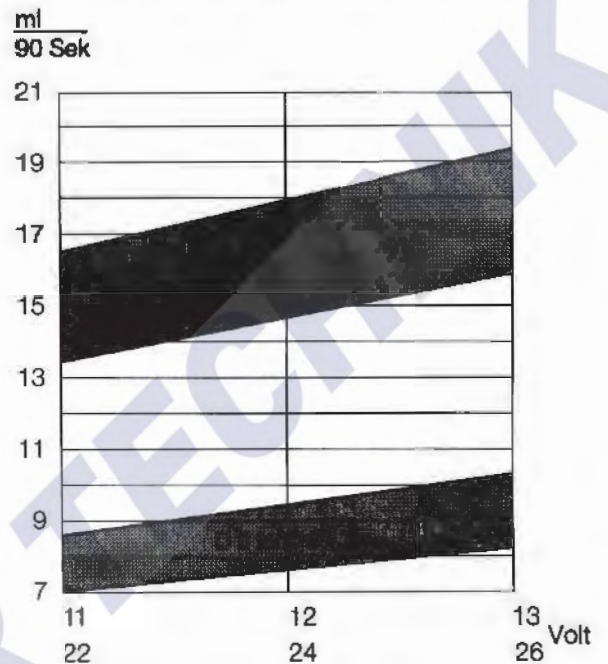

The fuel metering pump, when switched on, supplies:

- for B 5 L the fuel quantity for the "High" setting. Rated quantity at 12 V/24 V = 16.25 ml/90 secs.
- for D 5 L the fuel quantity for the "Medium" setting. Rated quantity at 12 V/24 V = 8.5 ml/90 secs.

Test apparatus

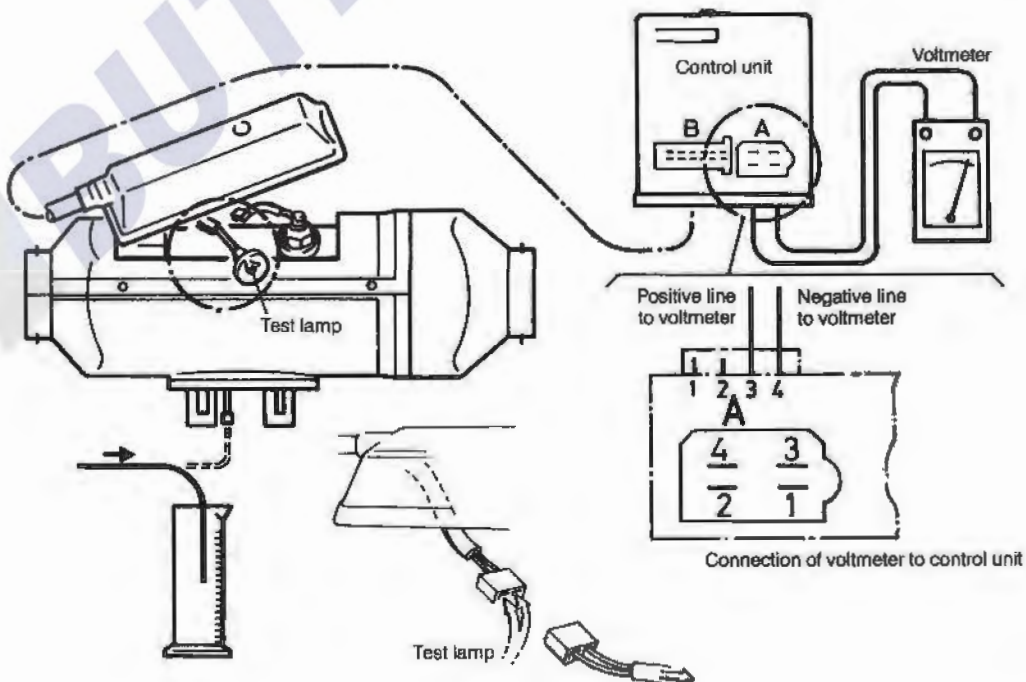



Using the test adapter and the test instrument for the operating unit

To identify certain faults (see page 5), the test adapter (PCB) and the test instrument for the operating unit are necessary.

1. Testing the blower motor

Detach the plug from the PCB, instead connect up a test adapter. Apply operating voltage + and - to the adapter. An ohmmeter is not required for this measurement. The blower motor must start up at once.

Measuring the speed:

Switch closed, 3000 rpm

Switch open, 800 rpm

Press button: the motor switches to high speed, 5000 rpm.

If the motor does not run:

Check PCB visually for burnouts.

If OK, change the blower.

If the speed changeover does not work, change the PCB.

2. Testing the safety thermal cutout switch:

The test lamp must come on as soon as the operating voltage has been connected.

If it does not come on, check the PCB, cable, plug contacts for breaks, check the safety thermal cutout switch for continuity.

3. Testing the temperature sensor (internal) and flame sensor:

The internal temperature sensor arranged on the PCB and the flame sensor arranged on the heat exchanger can be tested as follows (operating voltage does not have to be connected):

Connect an ohmmeter to the test adapter as shown in the sketch. The values given in the sketch must be complied with.

In the event of a fault, check the PCB for breaks or short-circuits.

If the temperature sensor is defective, replace the PCB; if the flame sensor value is ∞ , replace the flame sensor.

If an external temperature sensor is connected, its resistance value must be in the same range. For this purpose, connect the external temperature sensor directly to the ohmmeter.

Test adapter for PCB

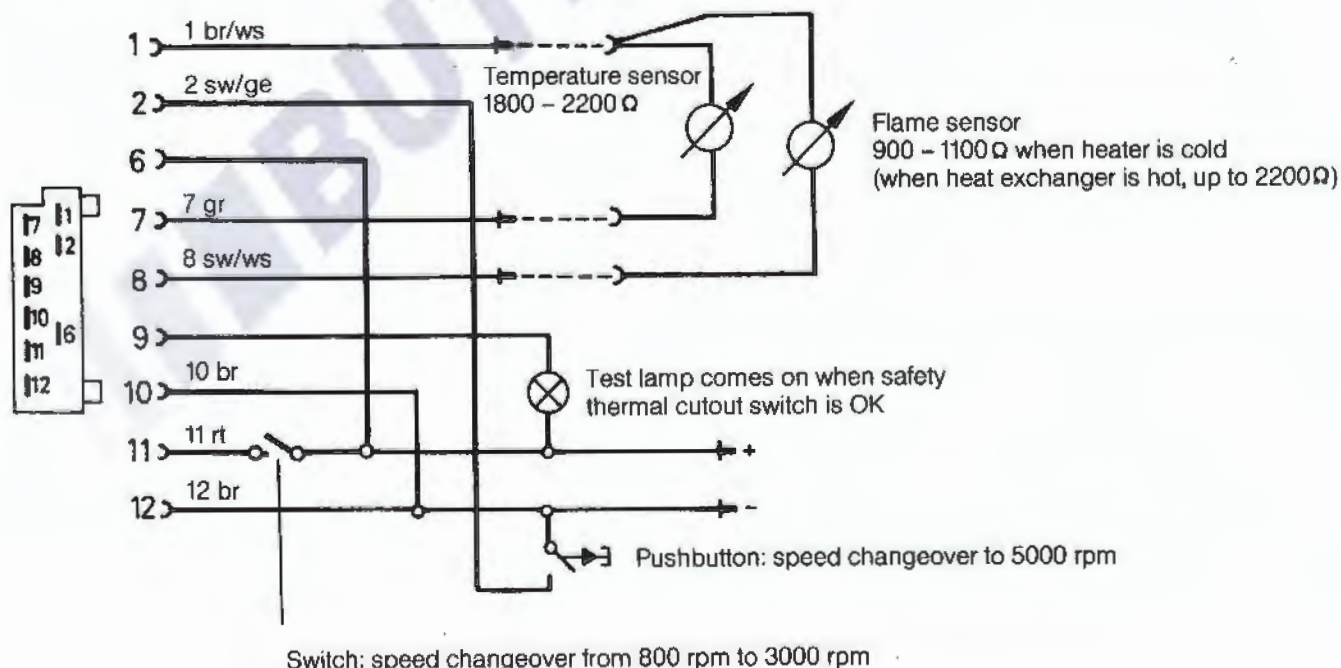

Test unit for operating device

Detach the plug of the operating device from the cable harness, instead connect the test unit to the operating device, and apply operating voltage.

Set the switch on the operating device to the "Heating and Ventilation" position. The appropriate lights must come on.

The pilot light in the switch must also come on.*

*This test is unnecessary in operation with heating timer.

Turn off the switch in the operating device. Call up lighting with key 1.

Press key 1, press key 2 in addition.

Pilot light must change from **red** to **green**.

Connect ohmmeter, turn rotary knob. Set value of 800 to 1200 must be maintained without a break.

In the event of an error change the operating device.

Test unit for operating device

