

AIRTRONIC D4 WORKSHOP DIAGNOSTIC AND REPAIR MANUAL



UNCONTROLLED
COPY

TABLE OF CONTENTS

REVISION LEVEL A - 09/09/15

Chapter	Content	Page
1	System Overview	3
2	Diagnostic Devices	4
3	Visual Inspection	6
4	Maintenance / Troubleshooting & Repair	11
5	Service Information	19
6	Parts Breakdown	26
7	Fuel Filter / Fuel Pump Angle	32
8	Ducting Rating Guide	33

PLEASE NOTE! The EW14 Warranty Process requires Edith extraction printouts to record codes before proceeding with repairs – and after the repair steps listed in this manual are completed. For your warranty claim to be paid you must document the Complaint, Cause and Correction steps in your warranty claim write-up.

⚠ CAUTION: Indicates that personal injury or damage to equipment may occur unless specific guidelines are followed.

DANGER: Indicates that serious or fatal injury may result if specific guidelines are not followed.

This document aims to support service technicians and end users in North America. This does not replace documentation produced by J. Eberspächer.

The installation instructions and standards described in this document are NOT APPLICABLE TO MARINE INSTALLATIONS. Please consult a certified Espar Marine dealer for marine installation.

This publication was correct at the time of going to print. However, Espar Inc. has a policy of continuous improvement and reserves the right to amend any specifications without prior notice.



1 SYSTEM OVERVIEW

REVISION LEVEL A - 09/09/15

SYSTEM OVERVIEW

The Espar Airtronic D2 heater is designed to lower idling by providing an alternative in cab heat solution

SYSTEM OPERATION

1. The operation turns on the device via either the Mini, Digi or Digi-Max Controller.
 - a. The Mini-Controller has a simple rheostat design for cab temperature control (Figure 1).
 - b. The Digi/Digi-Max Controller are digital devices that controls the cab temperature and also acts as a diagnostic device (Figure 2 & 3).

PLEASE NOTE! If the unit is equipped with a Digi-Controller and the display is showing H, the interior temp of the unit is too high to allow the Espar unit to operate. If the display is showing L, the unit will work but the temp is too cold to show the correct temp on the display.



2. When the heater is first started the following events take place:
 - a. The unit runs through a 3 second diagnostic check.
 - b. The fan and glow pin come on.
 - c. After 60 seconds the fuel pump starts pumping fuel.
 - d. If the unit doesn't fire within 2 1/2 minutes:
 - I. The unit will then stop the fuel pump and pause for 60 seconds.
 - II. The unit will then attempt a second start.
 - e. If the unit doesn't fire after the second attempt, a code 52 will be set. Refer to the fault code section of this document for proper troubleshooting.

PLEASE NOTE! Times are approximate, it is more important to understand there are 2 attempts and the process can take some time. After the second failed attempt, the heater fan motor will remain on for up to three minutes which is normal and part of the logic of the heater. The unit must be allowed time to run through its cycle. If there is an issue it will trip a code.

3. Inside the unit
 - a. The fan provides air flow through the combustion chamber and the ventilation hole.
 - b. The glow pin heats the atomizer chamber to preheat in preparation for fuel.
 - c. Fuel first enters below the ventilation hole.
 - d. It is then atomized and ignites.
 - e. The flame burns through the combustion chamber.
 - f. The flame sensor recognizes a temperature rise and then shuts off the glow pin.
 - g. The ECU measures the cab temperature via the return air temperature sensor in correlation with the set point (Figure 4).
 - h. Units utilizing the Digi/Digi-Max Controller do not utilize the return air temp sensor but instead use the remote air temperature sensor on the "Controller" (Figure 2 & 3 – page 3).
 - i. The unit switches between boost, high, medium, low and standby.
 - I. When it first ignites it is always in boost.
 - II. Mode is controlled via fuel pump frequency and fan speed.

1 SYSTEM OVERVIEW

REVISION LEVEL A - 09/09/15

SYSTEM OVERVIEW

- 4. Difference by controller operation
 - a. When operating in standby mode with a Mini-Controller the fan will continue to run in order to maintain airflow across the return air temperature sensor.
 - b. When operating in standby mode with a Digi/Digi-Max Controller the fan will shut down as air flow is not required.

PLEASE NOTE!

Any component replacement will require the serial number of the espar unit to be entered in order to charge the component to the work order. The serial number is located on the side of the Espar unit (Figure 5).

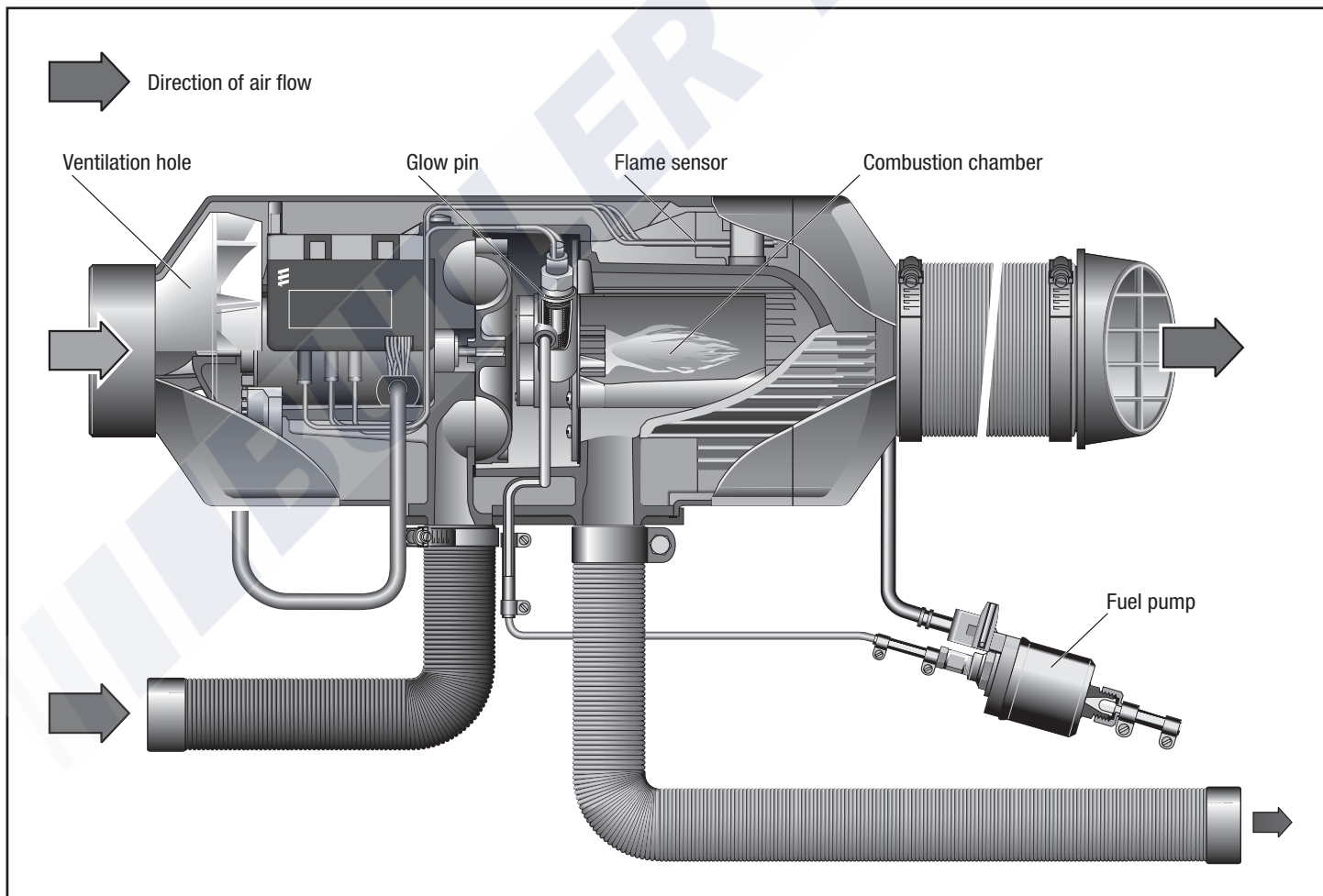



2 DIAGNOSTIC DEVICES

REVISION LEVEL A - 09/09/15

MULTIPLE DIAGNOSTIC DEVICES ARE AVAILABLE AS OUTLINED BELOW:

This manual is designed to be used with the Airtronic D2/D4. Please reference the data tag on your heater to verify which heater model you have. The Airtronic D2/D4 can utilize any of the fault code readers listed here.

1. EDiTH PC BASED DIAGNOSTICS – “PREFERRED”:

The ability to print out an ECU extraction is only available using EDiTH PC diagnostics, *and is a requirement for taking advantage of the EW14 express warranty protocols*. Full product testing capability including remote running of system components without removal of the heater, can be utilized for rapid fuel system priming.

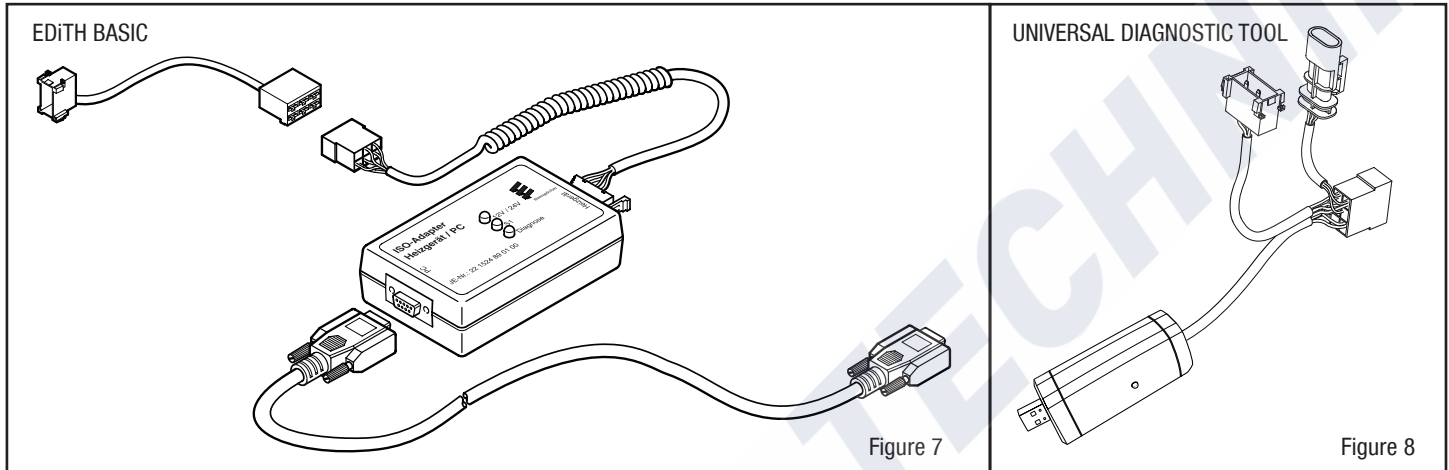

EDITH PC DIAGNOSTICS “PREFERRED”

EDITH Diagnostics Connection Quick Reference Card

Note: When connected, the green LED on the ISO adapter will indicate a 12 V power supply and the amber LED will indicate an active diagnostic line. A constantly lit red LED, may indicate a communication failure between the heater and the computer.

IMPORTANT: After the testing with EDITH, DO NOT disconnect the 'Y' shaped test adapter cable until the heater has been switched off and the cool-down process has been completed.

Hardware Required:

- 1) ISO adapter kit (EDITH basic adapter) : pin. 22 1541 89 0000

The kit includes:

- i) ISO adapter
- ii) Black spiral cable with 6-pin connector
- iii) 9-pin to 9-pin serial port connector cable
- iv) USB 2.0 to 9-pin serial port adapter cable
- v) CD with USB 2.0 to serial port software
- vi) CD with EDITH diagnostics software

Note: Install the EDITH software and the software for the USB 2.0 to 9-pin serial port adapter cable, before connecting the ISO adapter to the computer.

- 2) Test adapter cable (suited to individual heater type)

Commonly used test adapter cables:

- pin 22 1990 31 8600 : 'Y' shaped test adapter cable for Airtronic D2/D4/D5
- pin 20 2900 70 5028 : 'Y' shaped test adapter cable for Hydronic D5
- pin 20 2900 70 5046 : This universal 6-pin to 9-pin connector adapter cable connects the ISO adapter to any heater which has a diagnostic connector built into the main harness.

For a complete list of test adapter cables, please refer to www.espar.com/help.

EDITH Diagnostic Software

- EDITH is an acronym for **E**berspacher **D**iagnostic **T**ool **H**earer
- EDITH diagnostic software is available for free download from www.espar.com/help
- EDITH is compatible with most versions of Windows OS, including Windows 7.
- The current version of EDITH software is 33V11-F (as on June 2011).
- Always uninstall the older version before installing the newer version of the software.

EDITH Diagnostics Operation Quick Reference Card

Activating EDITH diagnostic tests

1. Double-click the EDITH shortcut on the desktop to launch the EDITH program
2. Click on the 'Select heater' icon from the navigation menu displayed
3. Select the heater type from the groups listed in the far left column (example: Airtronic / Airtronic M / L / DL / Hydronic 8/D 4/5/6/5/6C etc.)
4. Click and select the correct heater model number and the correct ECU version or click and run the 'Automatic detector' cycle
5. Select the diagnostic test to be activated in the far right column (example: Error memory, General Data, Functional check or Switch on component)
6. Click on 'Start test' button

EDITH diagnostic test options

General data: Displays total operating hours and in different heating stages, glow pin activations, number of start-attempts, number of successful ignitions, over-heat counter, failed startup counter, fault codes etc.

Functional check: Activates the heater and displays live data on the heater operation as it unfolds. This test displays components as they are activated or deactivated, the operational parameters being measured like temperature, speeds, frequency, voltages, heating modes etc. To switch to a graphic view, select the check boxes against the operational parameters and click on the 'graph' tab.

Switch on component: Enables independent activation and testing of the heater components including the blower fan, fuel metering pump, glow pin, coolant pump, etc. Any component defect will be indicated by a fault code. The fuel lines may be primed by independently activating the fuel metering pump.

NOTE: The scope of information displayed in these tests will depend on the type of heater and its ECU version. The fault codes can be cleared by clicking the 'Delete' button.

Espar Products, Inc.
www.espar.com 800-387-4800

Figure 9

2 DIAGNOSTIC DEVICES

REVISION LEVEL A - 09/09/15

2. DIAGNOSTIC UNIT

The diagnostic unit is solely used to read out, display and delete faults stored in the heater's electronic control box.

The electronic control box can store up to 5 faults

Please refer to user manual at www.espar.com/help ->diagnostic tools ->

Diagnostic unit 20 2900 70 50 60.

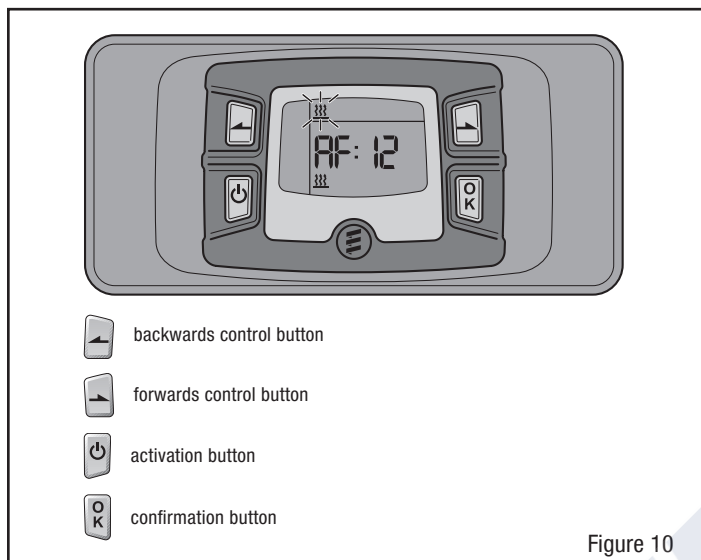

PERFORM THE DIAGNOSIS

Automatic detection

Five seconds after the diagnostic unit has been connected to the heater using the adapter cable, the automatic detection starts to determine the type of heater to which the diagnostic unit is connected.

PLEASE NOTE!

- If the automatic detection was successful, if necessary, the heater is briefly started and then switches off again.

Display until the automatic detection is completed.

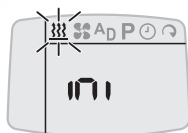

Display

- If a water heater has been detected Airtronic M,
- If air heaters 1L, 3L, 5L or Airtronic, Airtronic L air heaters (control box cable loom fixed, moulded) were detected.

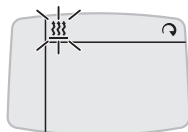

Confirm flashing symbol with

possible displays:

- if no errors/faults exist further action -> display fault memory, delete fault memory.



- If errors/faults exist further actions -> display current fault and fault memory, delete fault memory.



Display current fault in fault memory

Simultaneously press and

Display: e.g. AF : 12



Display fault memory F1 – F5

press or

Display: e.g. F1 : 20

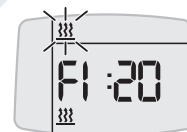

Delete the fault memory and as a result, at the same time cancel the control box lock

Current fault or fault F1 – F5

confirm with .

Confirm display dEL again with .

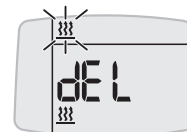

The fault memory is deleted and the control box is unlocked.

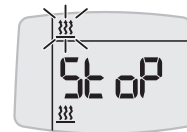

QUIT DIAGNOSIS Switch off heater

Press , the heater is switched off.

PERFORM THE DIAGNOSIS AGAIN

Press , the display is activated.

For further procedure, see left-hand column.

UNABLE TO PERFORM THE DIAGNOSIS Automatic detection was unsuccessful

Display if the automatic detection was not successfully completed.



Possible causes:

- bl/ws diagnostic cable not connected
- bl/ws diagnostic cable is defective -> check for continuity, short circuit and damage.
- Heater was not detected.



2 DIAGNOSTIC DEVICES

REVISION LEVEL A - 09/09/15

3. DIGI-DIAGNOSTIC TOOL/CONTROLLER

Inexpensive - basic code viewing & clearing functions.

While there are other fault code readers available, in this manual we are going to focus on only two methods – EDiTH PC diagnostics and the Digi-Controller (controller installed with the heater) / Digi-Diagnostic Tool (identical handheld tool).

1. First turn the controller on by pressing and releasing the instant ON / OFF key.
2. To review fault codes press and hold the instant ON/OFF until the display shows "da".
 - a. Codes will be displayed in the following manner:
 1. F0 will display first followed by the code number.
 2. This is the active code and is the code that should be repaired first.
 - a. Subsequent codes will be display with F1, F2, F3 etc. followed by the code number.
3. The "F1" simply indicates this is the first or most recent historical code and they go in order.
4. If there is not driver complaint, no active code, and the system is operating no repairs are needed codes should be cleared.
5. To clear fault codes:
 - a. While in diagnostic mode push and hold both arrow buttons until "EE" is displayed on the screen.
 - b. To exit diagnostic mode hit the ON / OFF button.
 - c. To shut the unit down hit the ON / OFF button again.

PLEASE NOTE!

ALWAYS document codes prior to clearing them - EVEN if no repairs are made.



Figure 11

PLEASE NOTE!

Prior to making repairs ALWAYS complete a visual inspection / operation inspection and note findings in the work performed section of your repair order.

PLEASE NOTE!

Any component replacement will require the serial number of the espar unit be entered in order to charge the component to the work order.

3 VISUAL INSPECTION

REVISION LEVEL A - 09/09/15

VISUAL INSPECTION

1. Complete a visual inspection using the following instructions:
 - a. Fuel Pump angle (Figure 12 and 13): Between 15 and 35 degrees- Inlet is low side, outlet is high side.
 - i. Yes
 - ii. No
 - iii. If no it will need to be reset to proper angle.

PLEASE NOTE!

It is very important that the pump angle is not reversed. When checking angle ensure that the inlet (side the fuel is drawn into the pump) is the low side and the outlet (side fuel exits the pump) is the high side. It is very important that the pump angle is not reversed (see figure 12 for proper mounting).

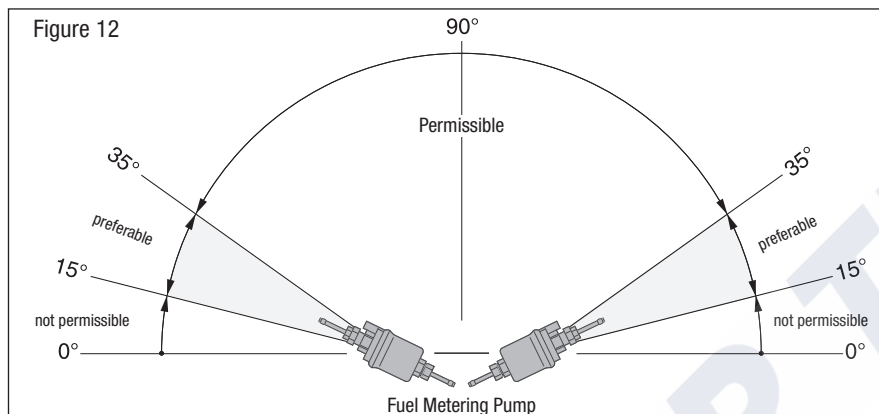

- b. Combustion Exhaust (flexible pipe only) - 1.5 to 2.5 inch extension past rear of cab?
 - i. Yes
 - ii. No
 - iii. If no, exhaust will need to be rerouted.
- c. Combustion Exhaust (Flexible pipe only) - No Kinks and not crushed.
 - i. Yes
 - ii. No
 - iii. If yes, exhaust will require repair.
- d. Combustion Exhaust (Flexible pipe only) - Bent facing the ground at least 45 degree angle?
 - I. Yes
 - II. No
 - III. If no, exhaust will need to be adjusted.
- e. Combustion exhaust (flexible pipe only) - Has low hanging areas.
 - i. Yes
 - ii. No
 - iii. If yes, eliminate the droop or drill a 1/8th inch condensation drain.
- f. Airflow intake (Figure 13 and 14) and exhaust free of obstruction or damaged venting.
 - i. Yes
 - ii. No
 - iii. If no, repair as needed.

PLEASE NOTE!

If the unit is equipped with a Digi-Controller and the display is showing H, the interior temp of the unit is too high to allow the Espar unit to operate. If the display is showing L, the unit will work but the temp is too cold to show the correct temp on the display.

2. Verify operation; if unit runs properly:
 - a. Record any historic codes in the work performed section, clear them and complete the job.
 - b. If the unit does not operate properly continue below.
3. Using either the Digi-Controller/Diagnostic Tool or Edith, check for fault codes and utilize the troubleshooting steps listed.



3 VISUAL INSPECTION

REVISION LEVEL A - 09/09/15

PLEASE NOTE!

Return air must be clear from obstructions. If the carpet is too close, cut away from the inlet of the Espar heater to allow for more clearance. Outlet air must be clear from obstructions.

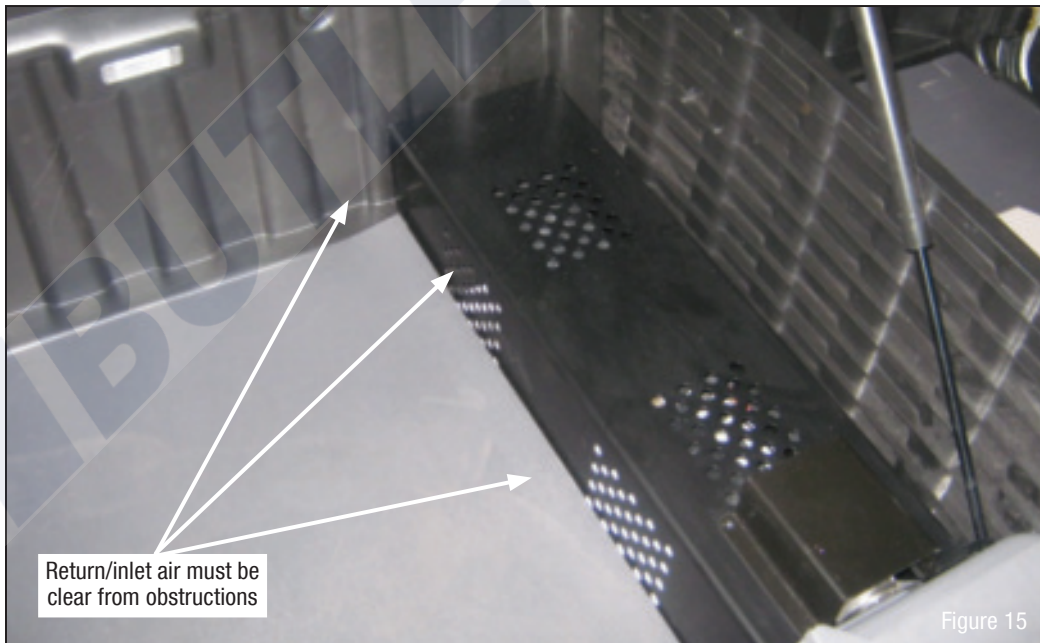
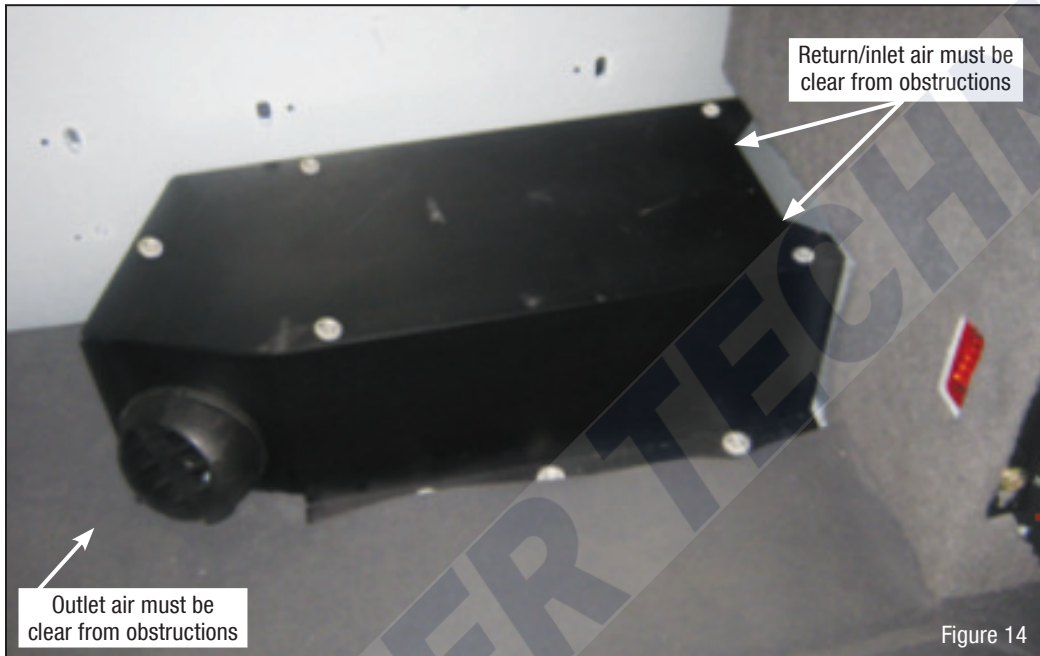

4 VISUAL INSPECTION

REVISION LEVEL A - 09/09/15

TYPICAL NON-WARRANTABLE REPAIRS

1. FUEL FILTER
 - a. The fuel filter can be found on the inlet side of the fuel pump, see page 32. If this filter is plugged or partially plugged it can cause a no-start to your heater. The filter can be serviced by using a backing wrench and turning the inlet cap off the pump. Then use a small pick to pull the filter out to be replaced.
 - b. This filter may cause the heater to smoke during start-up and smoke during operation.
 - c. This filter can cause your heater to over fuel due to repetitive start attempts.
 - d. Common codes associated with a fuel filter: 50 – 56.
2. ATOMIZER SCREEN
 - a. This screen surrounds the glow pin and is found when the glow pin is removed
3. OVERHEAT AND ASSOCIATED FAILURES (Code 12,14 &15) are normally non-warrantable failures
4. PLUGGED OR RESTRICTED COMBUSTION INTAKE AND/OR EXHAUST PIPING
5. CARBONED BURNER CHAMBER – these are non-warrantable unless caused by a primary failed part covered under a warrantable failure situation.
 - a. Caused by a restriction of intake or exhaust.
 - b. Caused by improper angle of fuel pump, pump must be 15 – 35 degree angle up with the outlet / harness connection being on the high side.
 - c. Fuel system that has had improper amount of additives injected into the tank.
 - d. Fuel system with any kind of oil being used in the fuel.
 - e. Short cycling caused by improper application or electrical power connections.
6. MODIFIED PARTS DURING REMOVAL OR REPAIR WHILE UNDER WARRANTY



4 FAULT CODE / TROUBLESHOOTING

REVISION LEVEL A - 09/09/15

IF THERE IS NO COMMUNICATION -

Fault reader displaying - - - (dash dash dash) or non-functional Espar unit without fault codes

1. Check units open circuit voltage at the batteries.
2. If the voltage is below 12.6 (Flooded cell) or below 12.8 (AGM) charge the batteries to a minimum of 12.4 volts (must be above the system LVD setting) following your company's standard practices and restart troubleshooting.
 - a. Otherwise continue below.
3. Connect Diagnostic Interface adapter (Figure 15).
4. Using the "Y" adapter and multi-meter:
 - a. Perform a continuity test to verify ground on the brown wire of 0 ohms.
 - b. Perform a voltage test to verify battery power between the red wire and the brown wire.
 - I. If voltage is below 10.5 volts troubleshoot the tractor's wiring utilizing the manufacturer's documentation –
 - II. [Check for harness voltage drop to the heater.](#)
 - c. Perform a test to verify continuity to the diagnostic reader at blue wire-white tracer at the white connector and blue wire-yellow tracer on the Espar heater.
 - I. If wires are damaged repair wires.
 - II. [Always use heat shrink, solder or connectors with heat shrink tubing when making wiring repairs.](#)

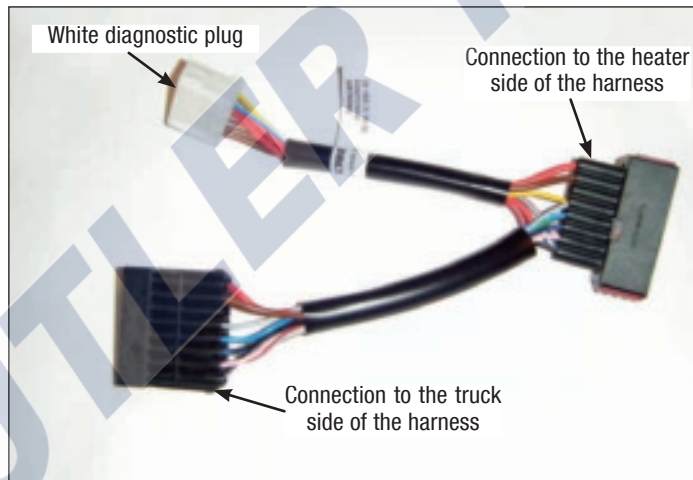

Figure 16

5. If the problem persists connect the test harness (Figure 15) and wire the Espar directly to the batteries.
 - a. Plug the 8 pin adapter test harness in series with the Espar harness at the heater.
6. Use a known [good battery](#) (12 volt min.) and supply external power using the white connector plug (heavy red wire=power, heavy brown wire=ground).
7. If the problem persists, replace the control unit (ECU).

4 FAULT CODE / TROUBLESHOOTING

REVISION LEVEL A - 09/09/15

FAULT CODE / TROUBLESHOOTING

PLEASE NOTE!

EW13 Warranty Process requires an Edith extraction printout to record codes before proceeding. Remember to carefully document the Complaint – Cause and Correction.

000 - NORMAL OPERATION

1. No Repairs needed.

010 - OVER-VOLTAGE

1. System maximum voltage is 16 volts.
2. The possible causes of this code are (non-warranty).
 - a. A battery charger in boost mode.
 - b. Alternator overcharging.
3. Clear the code repair as needed

011 - UNDER VOLTAGE SHUT DOWN

1. System minimum voltage is 10.5 volts.
2. Verify battery voltage.
3. Install the Y interface adapter.
4. Connect the multi-meter to the red and brown wires and set to volts DC.
5. Record the voltage
6. If the voltage is less than 12.6 (flooded cell) 12.8 (AGM) connect the battery charger and log off the job until the batteries are fully charged, otherwise continue below. (See note on page 11)
7. Turn on the unit while watching the multi-meter.
8. If the voltage remains above 10.5 clear the code, no repairs are needed, otherwise continue below.
9. Troubleshoot the tractors wiring harness utilizing the factory manuals – [check for voltage drop to the heater](#).
10. Clear codes when repaired.

012 - OVERHEAT AT OVERHEATING SENSOR

1. Sensor has detected excessive temperatures.
2. Using shop air, blow out the heat exchanger and airflow ducting including the heating air intake.
3. Check airflow ensuring the ducting is free from obstructions especially the bunk inlet and outlet.
4. Check ducting rating of the installed heater. See page 33.
5. Remove the sensor, check connections, wiring and reinstall.
6. If the wiring is damaged or connection is corroded, replace the sensor, otherwise continue below.
7. Clear code and run unit.
8. If code returns replace the sensor.
9. Clear code and run unit ensuring issue is resolved.

013 - OVERHEAT AT FLAME SENSOR

1. Flame sensor detects excessive temperature at heat exchanger.
Using shop air, blow out the heat exchanger and airflow ducting including the intake.
2. Check airflow ensuring the ducting is free from obstructions especially the bunk inlet and outlet.
3. Check ducting rating of the installed heater. See page 33.
4. Remove the sensor, check connections, wiring and reinstall.
5. If the wiring is damaged or connection is corroded, replace the sensor, otherwise continue below.
6. Check fuel pump angle and correct if needed.
 - A. If correction was needed, clear the fault and run unit.
7. If fault code doesn't return complete the job, otherwise continue below.
8. Measure fuel quantity.
 - a. Disconnect the fuel line from heater
 - b. Turn the unit on (remember 60 second delay prior to pump activation)
 - c. Place the fuel line into the graduated cylinder and allow to run through a first start attempt.
 - d. Once fuel pump stops running from first start attempt turn the unit off
 - e. Measured fuel must be between 3.5 to 4.3 milliliters. If the reading is high and the pump angle is verified correct, replace the pump, clear the codes, run the unit, otherwise skip to step 16.
9. If fault code doesn't return complete the job otherwise continue below.
10. Replace the sensor



4 FAULT CODE / TROUBLESHOOTING

REVISION LEVEL A - 09/09/15

014 - TEMPERATURE DIFFERENCE BETWEEN FLAME SENSOR AND OVERHEAT SENSOR TO LARGE

1. Using shop air, blow out the heat exchanger and airflow ducting including the intake.
2. Check airflow ensuring the ducting is free from obstructions especially the bunk inlet and outlet.
3. Check ducting rating of the installed heater. See page 33.
4. Remove the sensor, check connections, wire and reinstall.
5. If the wiring is damaged or connection is corroded, replace the sensor, otherwise continue below.
6. Check fuel pump angle and correct if needed.
7. If correction was needed, clear the fault and run unit.
8. If fault code doesn't return complete the job, otherwise continue below.
9. Measure fuel quantity.
 - a. Disconnect the fuel line from heater.
 - b. Turn the unit on (remember 60 second delay prior to pump activation).
 - c. Place the fuel line into the graduated cylinder and allow to run through a first start attempt.
 - d. Once fuel pump stops running from first start attempt turn the unit off.
 - e. Measured fuel must be between 3.5 to 4.3 milliliters.
10. If the reading is high and the pump angle is verified correct, replace the pump, clear the codes, and run the unit.
11. If the reading is low, and the pump angle is verified correct, replace the inlet filter and retest
12. If fault code doesn't return complete the job otherwise continue below.
13. Replace the sensor.

015 - OVERHEAT WITH EXCESSIVE TEMPERATURES

1. Sensor has detected excessive temperatures.
2. This code indicates that Code 017 was set and the unit was restarted.
3. This code indicates that the heaters has been overheated repeatedly consecutive times.
4. Unlock control unit by reviewing all codes.
 - a. Document all codes.
 - b. Clear codes (once codes are cleared the lockout will be cleared)
5. Using shop air, blow out the heat exchanger and airflow ducting including the intake.
6. Check airflow ensuring the ducting is free from obstructions especially the bunk inlet and outlet.
7. Check ducting rating of the installed heater. See page 33.
8. Remove the sensor, check connections, wiring and reinstall.
9. If the wiring is damaged or connection is corroded, replace the sensor, otherwise continue below.
10. Run unit.
11. If Code (either 015 or 017) returns replace the sensor.
12. Clear code and run unit.
13. If code returns reinstall original sensor and replace control unit.
14. Run unit ensuring issue is resolved.

016 - OVERHEAT WITH EXCESSIVE TEMPERATURE

1. This code is set when excess temperature is seen at the overheat sensor.
2. See Code 015.

019 - GLOW PIN POWER CONSUMED BY GLOW PIN IS TOO LOW

1. Unplug the glow pin.
2. Inspect the wire and plug condition; if damaged replace the glow pin, otherwise plug back in.

PLEASE NOTE!

Take care when working with the glow pin - damaged wires or broken glow pins are not a warrantable failure.
Do not twist the wiring during removal. See Basic Repair Analysis Guide / Non-Genuine – glow pins failing under warranty must be returned

3. Clear codes and run unit.
4. If code returns replace the glow pin.
5. Clear codes and run unit.
6. If code returns replace control unit and reinstalled the removed glow pin.

020 - OPEN CIRCUIT - GLOW PIN (BE CAREFUL NOT TO PULL WIRES OFF GLOW PIN DURING REMOVAL)

1. Inspect glow pin leads for continuity, replace if necessary
2. Check for corrosion in terminals (maintenance)

021 - SHORT CIRCUIT - GLOW PIN (BE CAREFUL NOT TO PULL WIRES OFF GLOW PIN DURING REMOVAL)

1. Inspect glow pin leads for continuity, replace if necessary.
2. Check for corrosion in terminals (maintenance).

4 FAULT CODE / TROUBLESHOOTING

REVISION LEVEL A - 09/09/15

025 - DIAGNOSTICS CABLE BLUE/WHITE - SHORT CIRCUIT

1. Refer to "No Communication"

031 - BLOWER MOTOR INTERRUPTED

1. Visually inspect air inlet for scratches on impeller. If the fan has visible rub marks, locate cause and correct, this is not a warrantable failure)
2. Run unit and listen for rubbing.
3. Turn blower by hand checking for hard spots.
4. If any rubbing, scratches, or binding is found resolve the issue:
 - a. Possible causes:
 - i. Physical obstruction
 - ii. Ducting clamp over-torqued
 - iii. Floor mat or debris under heater when mounted
5. If a hard spot is noted and no intake issue are found remove blower motor and inspect the combustion fan and replace the whole assembly if necessary.
 - a. A warped combustion fan is caused by short cycling and a power interruption while running.

032 - BLOWER MOTOR SHORT CIRCUIT

1. Install test ECU
2. Clear codes and run unit.
3. If problem is resolved leave new control unit in the Espar.
4. If problem is not resolved replace blower, reinstall the previous control unit and restart the troubleshooting.

033 - Blower motor speed failure.

1. Motor speed varies from specification by more than 10% for longer than 30 seconds.
2. Inspect the control unit ensuring it is secure.
3. Fan speed is measured from a small magnet located on the fan wheel and the ECU itself.
4. A loose ECU will cause inaccurate readings.
5. If the ECU is loose, tighten the screw.
6. If the screw is stripped install a larger screw.
7. Clear codes and run unit.
8. If code persists continue below otherwise clear historic codes and complete the job.
9. Check heating air intake for obstructions ensuring the blower turns freely.
10. See steps for Code 31
11. Clear codes and run unit.
12. If problem persists install test control unit.
13. Clear codes and run unit.
14. If problem is resolved leave new control unit in the Espar.
15. If problem is not resolved replace blower, reinstall the previous control unit and restart the troubleshooting.

034 - Blower motor outlet (+) short circuit after B+ (battery voltage).

1. Inspecting wiring from blower motor to control unit.
2. If damaged replace blower otherwise continue below
3. Install test control unit.
4. Clear codes and run unit.
5. If problem is resolved leave new control unit in the Espar.
6. If problem is not resolved replace blower, reinstall the previous control unit and restart the troubleshooting.

047 - SHORT CIRCUIT OR OVERLOAD - FUEL METERING PUMP (FMP)

1. Fuel pump positive wire (green w/red) is shorted to chassis ground.
2. Inspect wiring for damage, check continuity from 16 pin to fuel pump plug and repair using a heat shrink solder butt connector as needed.
If not damaged continue below.
3. Unplug the fuel pump and power up unit.
4. If fault Code 48 is displayed fuel pump is defective.
5. If fault Code 48 is not displayed recheck wiring.
6. If still not resolved install test ECU.
7. If problem is resolved leave test unit in, clear codes and run unit.



4 FAULT CODE / TROUBLESHOOTING

REVISION LEVEL A - 09/09/15

048 - OPEN CIRCUIT - FUEL METERING PUMP (FMP)

Disconnect connector from fuel pump and measure resistance value of fuel pump see values, pg. 20. If resistance values are O.K., then reconnect cable harness to the fuel pump.

1. Check fuel pump electrical connector.
 - a. Pins of female plug end can become spread.
 - b. Re-crimp if needed.
 - c. Clear code and run unit.
 - d. If problem persists continue below.
2. Inspect the wiring for damage, check continuity from the 8 pin housing for an external FMP, and 14 pin housing for an internal FMP.

050 - TOO MANY NO START ATTEMPTS - (LOCKOUT)

PLEASE NOTE!

This is normally not a warrantable failure.

1. Document and clear fault codes.
2. Restart troubleshooting.
 - i. Reference Code 52.

051 - FAULTY FLAME RECOGNITION

1. Document codes, clear codes, and run unit.

PLEASE NOTE!

This code is caused from a hard shutdown (power cut off) which prevents a cool down. If upon next start the sensed temperature is excessive the unit will run a cool down cycle. If the sensed temperature doesn't fall enough a Code 051 is set. This can be a loose power wire or using the master cutoff while the unit is running.

2. If problem persists install test flame sensor.
3. If problem is resolved leave sensor in, clear codes, and run unit.
Also refer to Code 52 for no-start situations.

052 - NO START SAFETY TIME EXCEEDED

1. No flame detected on start attempt but unit diagnostics are unable to detect a fault.
2. Check exhaust and combustion piping for restriction (non-warranty).
 - a. Low spots.
 - b. Crushes and kinks.
3. Inspect and or replace fuel filter on inlet side of fuel pump, see page 32 (maintenance).
4. Check fuel pump operation.
 - a. Pump should tick, if so continue to step 5 if not continue below.
 - b. Install test pump, clear codes and run unit.

PLEASE NOTE!

You cannot probe the fuel pump plug for voltage - this sets a Code 48 and prevents the unit from running.

- c. If problem is resolved install pump, clear codes, run unit and restart troubleshooting. Otherwise continue below.
- d. Troubleshoot wiring from pump to harness (non-warranty).
- e. If wiring is damaged repair as needed using heat shrink & solder butt connectors.

4 FAULT CODE / TROUBLESHOOTING

REVISION LEVEL A - 09/09/15

5. Check fuel supply/measure fuel quantity.
 - a. Disconnect the fuel line from heater
 - b. Turn the unit on (remember 60 second delay prior to pump activation)
 - c. Place the fuel line into the graduated cylinder and allow to run through a first start attempt.
 - d. Once fuel pump stops running from first start attempt turn the unit off.
 - e. The measured fuel must be between 3.5 to 4.3 milliliters. Refer to page 19.
 - f. If the reading is high and the pump angle is verified correct, replace the pump, clear the codes, run the unit, and restart troubleshooting.
 - g. If the reading is low and the pump angle is verified correct, replace inlet screen and retest.
 - h. Inspect all fuel line connections to see if the lines have a crisp cut on the end. Inspect fuel pick-up pipe for any obstructions.

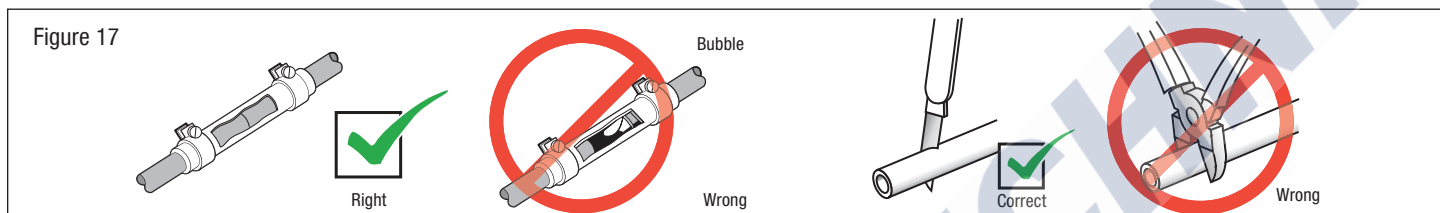

- i. If no fault is found on the inlet line or pick-up pipe operate the fuel quantity test from an external fuel source.
 - j. If results are still low replace pump.
6. Replace atomizing screen, clean starting air hole (maintenance) and inspect glow pin.
 - a. If pin visibly deteriorated replace it, clear codes and restart troubleshooting.
 7. Check flame sensor resistance, see pages 19 & 23.
 8. Remove and inspect the burner chamber (see pictures in the Basic Repair Analysis guide).
 - a. If burner chamber has carbon build up replace the burner chamber
 1. Soft carbon: (non-warranty).
 - a. Is an indication of over fueling (FMP angle).
 - b. Restricted exhaust.
 - c. Restricted intake.
 - d. Plugged blower wheel.
 2. Hard carbon: (non-warranty)
 - a. Is an indication of too much additives.
 - b. Heavy concentration of bio-fuel.
 - c. Short cycle of heater (recommended minimum runtime is 15 minutes).
 - d. Road debris (reposition combustion air intake to a location not to pick-up debris).
 - e. Clear codes and run unit.

053 - Flame cutout power/boost mode

054 - Flame cutout in high mode

055 - Flame cutout in medium mode

056 - Flame cutout in low mode

1. Heater has started successfully but the flame has extinguished.
2. Inspect and or replace fuel filter on inlet side of fuel pump, see page 32. (maintenance).
3. Inspect for possible air entry into the suction side of the fuel system.
4. Check fuel supply/measure fuel quantity.
 - a. Disconnect the fuel line from the heater.
 - b. Turn the unit on (remember the 60 second delay prior to pump activation).
 - c. Place the fuel line into the graduated cylinder and allow to run through a first start attempt.
 - d. Once the fuel pump stops running from the first start attempt turn the unit off.
 - e. The measured fuel must be between 3.5 to 4.3 milliliters. Refer to page 19.
 - f. If the reading is high and the pump angle is verified correct (15-35), replace the pump, clear the codes, run the unit, and restart troubleshooting.
 - g. If the reading is low and the pump angle is verified correct, replace inlet screen and retest.
 - h. Inspect all fuel line connections to see if the lines have a crisp cut on the end (Figure 13). Inspect fuel pick-up pipe for any obstructions.

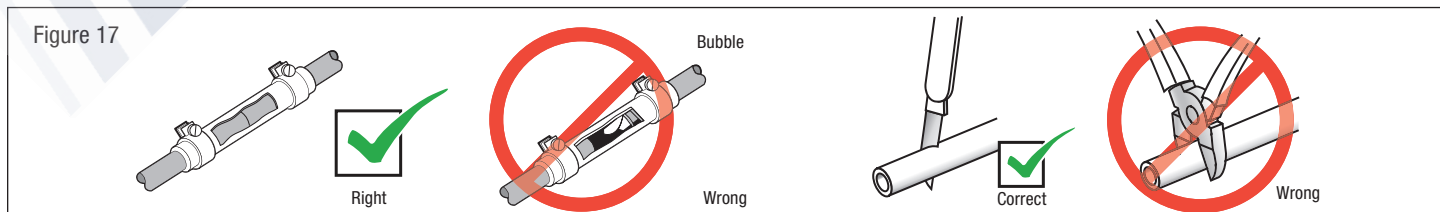

- i. If not fault is found on the inlet line and pick-up pipe operate the fuel quantity test from an external fuel source.



4 FAULT CODE / TROUBLESHOOTING

REVISION LEVEL A - 09/09/15

5. Check exhaust and combustion air intake lines (maintenance)
 - a. Low spots
 - b. Crushed and kinked areas
 - c. At least a 45 degree downward angle in exhaust piping
6. Test flame detector, see page 20.

057 - Flame cutout during start phase.

1. Unit is seeing sensed heat prior to fuel pump engagement- Often flooded chamber due to fuel supply issues.
2. Check fuel supply/measure fuel quantity.
 - a. Disconnect the fuel line from heater.
 - b. Turn the unit on (remember 60 second delay prior to pump activation).
 - c. Place the fuel line into the graduated cylinder and allow to run through a first start attempt.
 - d. Once fuel pump stops running from first start attempt turn the unit off.
 - e. Measured fuel must be between 3.5 to 4.3 milliliters. Refer to page 19.
 - f. If the reading is high and the pump angle is verified correct, replace the pump, clear the codes, and run the unit, and restart troubleshooting.
 - g. If the reading is low, replace the fuel filter located on the inlet side of the pump and re-run quantity test otherwise clear codes and restart troubleshooting.
 - h. If results remain low after servicing the fuel filter, replace the fuel pump and re-run quantity test -otherwise clear the codes and restart troubleshooting.
 - i. If, after steps G & H, the results are still low check the fuel stand pipe for obstructions - otherwise clear codes and restart troubleshooting.
3. Check exhaust and combustion lines.
 - a. Low spots
 - b. Crushed and kinked areas
 - c. At least a 45 degree downward angle in exhaust piping extended 1.5" to 2.5" past rear of cab.
4. Using shop air, blow out the heat exchanger and airflow ducting including the intake.
5. Remove the sensor, check connections, wire and reinstall.
6. If the wiring is damaged or connection is corroded, replace the sensor, otherwise continue below.
7. Install test sensor, clear codes and run unit.
8. If problem is resolved leave sensor in and restart troubleshooting.
9. If problem persists install test control unit, clear codes and run unit.
10. If problem is resolved install old sensor, leave in control unit, clear codes and restart troubleshooting.
If problem persists contact tech support at 800-387-4800.

PLEASE NOTE!

Before beginning any troubleshooting review pages 6-7 and ensure the visual checklist has been completed.

060 - Open circuit - external temperature sensor (Digi / Digi-Max Controllers only).

1. Temperature sensor detects a value beyond its range.
2. Replace Digi-Controller.

061 - Short circuit - external temperature (Digi / Digi-Max Controllers only).

1. Temperature sensor detects a value beyond its range.
2. Replace Digi-Controller.

062 - THERMOSTAT / RHEOSTAT TIMER, OPEN CIRCUIT

1. Fault reader connected prior to turning on temp controller or faulty temp controller.
2. Clear code and run unit.
3. If problem persists inspect control unit wire harness for damage or loose connection and repair if needed (solder but connectors & use heat shrink).
4. If problem persists replace Digi-Controller or Mini-Controller.
5. If problem persists install test ECU.
6. If problem is resolved leave in test ECU, clear codes and restart troubleshooting.
If problem persists contact tech support 800-387-4800.

063 - SWITCH CONTROL - SHORT CIRCUIT

1. If a ventilating switch has been built in, disconnect and check function. If faulty, replace switch.
2. Disconnect wires from thermostat or switch. If fault Code 062 is displayed, replace switch.
3. If switch is O.K., check connection of grey/red wire and brown/white wire for short-circuit.
4. If O.K., reconnect wires to thermostat/control. Disconnect connection B1 (16 pin connector on vehicle of harness). If fault Code 063 is still displayed, replace control unit.

4 FAULT CODE / TROUBLESHOOTING

REVISION LEVEL A - 09/09/15

064 - OPEN CIRCUIT - FLAME SENSOR

1. Open Airtronic shell and remove ECU from casing. Install test sensor, clear codes and run unit.
2. If problem is resolved leave sensor in and restart troubleshooting.
3. If problem persists install test ECU, clear codes and run unit.
4. If problem is resolved install old sensor, leave in ECU, clear codes and restart troubleshooting. If problem persists contact tech support at 800-387-4800.

065 - SHORT CIRCUIT - FLAME SENSOR

1. Open Airtronic shell and remove ECU from casing.
2. Disconnect green connector from ECU. If fault Code 064 is displayed, replace combination sensor (flame/temperature).
3. If fault Code 065 is still displayed, replace ECU.

071 - OPEN CIRCUIT - OVERHEAT SENSOR

1. Open Airtronic shell and remove ECU from casing. Install test sensor, clear codes and run unit.
2. If problem is resolved leave sensor in and restart troubleshooting.
3. If problem persists install test ECU, clear codes and run unit.
4. If problem is resolved install old sensor, leave in ECU, clear codes and restart troubleshooting. If problem persists contact tech support at 800-387-4800.

072 - SHORT CIRCUIT - OVERHEAT SENSOR

1. Open Airtronic shell and remove ECU from casing.
2. Disconnect blue connector from control unit.
3. If fault Code 071 displayed, replace combination sensor (flame/temperature).
4. If fault Code 072 is still displayed, replace control unit.

074 - CONTROL BOX DEFECT

1. Overheating threshold value is not detected by ECU, replace ECU.

090 - CONTROL UNIT DEFECTIVE **

091 - EXTERNAL VOLTAGE DISTURBANCE ** (MAINTENANCE)

1. Check vehicle charging system. Poor battery, battery charger, eliminate fault.

092 - 103 - CONTROL UNIT DEFECTIVE **

** Disconnect heater from power for 10 seconds by disconnecting the 14 pin connector at the heater or pull the 20 amp fuse. Reconnect and test again. If the problem persists, test the heater using an external power source other than the vehicle (known good battery only). These faults are common to a bad power supply, attached charger or dead cell in a battery.

If problem persists install test control unit, clear codes and run unit.



5 SERVICE INFORMATION

REVISION LEVEL A - 09/09/15

FUEL QUANTITY TEST

The fuel quantity should be tested if the heater has difficulty starting or maintaining a flame.

PREPARATION

- Detach the fuel line from the AIRTRONIC.
- Insert the fuel line into a graduated cylinder 10ml.
- Switch the AIRTRONIC on. Once the FMP comes on allow the fuel system to bleed air out for approximately 60 seconds.
- Switch the AIRTRONIC off and empty the graduated cylinder.

MEASUREMENT

- Switch the AIRTRONIC on.
- The fuel is pumped approx. 60 seconds after switching on.
- Hold the fuel line in the graduated cylinder level with the glow pin while fuel is being delivered.
- The pump will stop automatically after delivering fuel for 90 seconds (110 seconds for AIRTRONIC 4).
- Once fuel pump stops, switch off the heater.

EVALUATION

- Read out the quantity of fuel in measuring glass.
- Fuel quantity should be between:
 - 3.5 ml and 4.3 ml. on AIRTRONIC D2
 - 5.0 ml and 6.0 ml. on AIRTRONIC D4
 - 6.8 ml and 7.6 ml. on AIRTRONIC B4

- Replace the fuel metering pump if the fuel quantity is above specified value.
- If measured fuel quantity is insufficient:
- Check the filter in the fuel pump.
 - Check that the fuel lines are correctly routed.
 - Check that the fuel lines don't leak.
 - Check and tighten hose connections.
 - Does fuel withdrawal comply with the data in the technical description.

PLEASE NOTE! The fuel quantity is not affected by voltage variances.

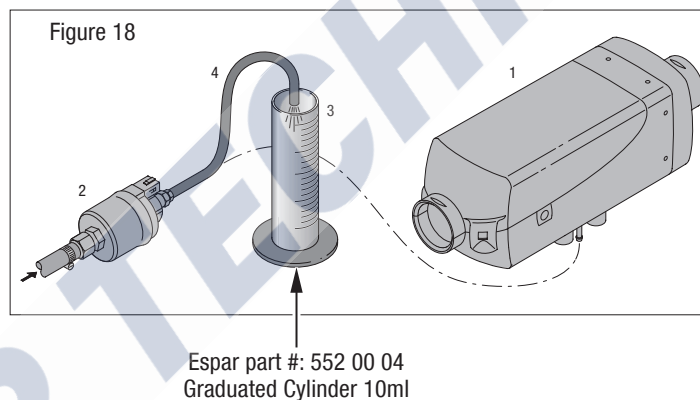

VALUES FOR OVERHEAT SENSOR

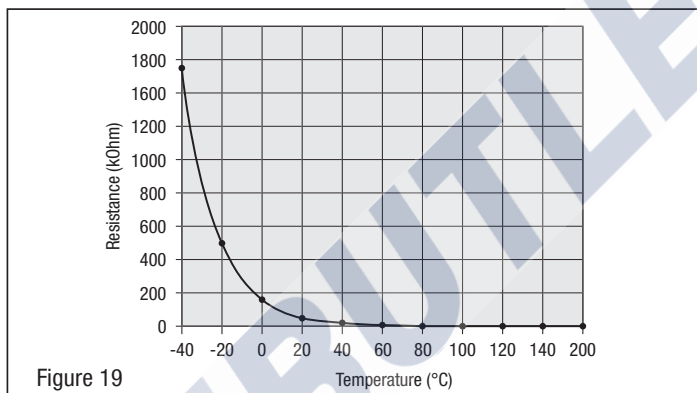

Temperature °C (F°)	Resistance kΩ	min.	max.
-40 (-40)		1597.0	1913.0
-20 (-4)		458.80	533.40
0 (32)		154.70	175.50
20 (68)		59.30	65.84
40 (104)		25.02	28.04
60 (140)		11.56	13.16
80 (176)		5.782	6.678
100 (212)		3.095	3.623
120 (248)		1.757	2.081
140 (284)		1.050	1.256
160 (320)		0.6654	0.792
180 (356)		0.4253	0.5187
200 (392)		0.2857	0.3513

VALUES FOR FLAME SENSOR

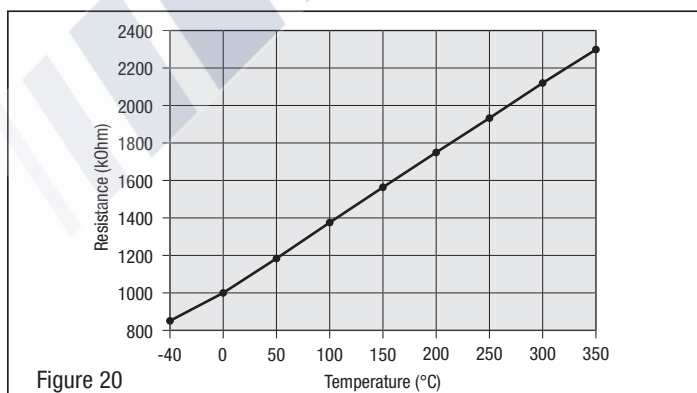

Temperature °C (F°)	Resistance Ω	min.	max.
-40	842.7	825.9	859.6
-20	921.6	803.2	940.0
0	1000.0	980.0	1020.0
20	1077.9	1056.4	1099.5
40	1155.4	1132.3	1178.5
60	1232.4	1207.8	1257.1
80	1308.9	1282.8	1335.1
100	1385.1	1357.4	1412.8
120	1460.7	1431.5	1489.9
140	1535.8	1505.1	1566.6
160	1610.5	1578.3	1642.8

5 SERVICE INFORMATION

REVISION LEVEL A - 09/09/15

CONTROL VALUES

MOTOR SPEED

Test speed for the blower heater

AIRTRONIC D2 / D2 Camper

12 volt heater 5000 rpm $\pm 25\%$ at U = 10.0 volt

AIRTRONIC D2

24 volt heater 5000 rpm $\pm 25\%$ at U = 18.0 volt

AIRTRONIC M B4 / D4 / D3 Camper / D4 Camper

12 volt heater 4400 rpm $\pm 25\%$ at U = 10.0 volt

AIRTRONIC M D4

24 volt heater 4400 rpm $\pm 25\%$ at U = 18.5 volt

AIRTRONIC M D4S / D4 Camper plus

12 volt heater 4400 rpm $\pm 25\%$ at U = 10.5 volt

AIRTRONIC M D4S

24 volt heater 4400 rpm $\pm 25\%$ at U = 19.0 volt

CONTROL STAGE D2 D4

- Power
- Fast
- Medium
- Slow
- Adjustment
 - in circulation mode with temperature sensor, internal
 - In fresh air mode with temperature sensor, external
- Ventilation

AIRTRONIC D2

4800 U/min ± 140 rpm
 4000 U/min ± 120 rpm
 2800 U/min ± 80 rpm
 2000 U/min ± 60 rpm

600 U/min ± 20 rpm
 0 rpm
 4800 U/min ± 140 rpm

AIRTRONIC D4

4400 U/min ± 130 rpm
 3500 U/min ± 100 rpm
 2600 U/min ± 80 rpm
 1600 U/min ± 50 rpm

600 U/min ± 20 rpm
 0 rpm
 4400 U/min ± 100 rpm

RESISTANCE VALUES

COMPONENT

Glow pin	<i>AIRTRONIC D2- 12V</i>	<i>AIRTRONIC D2- 24V</i>
Fuel metering pump	0.42 - 0.7 Ω	1.2 - 2.0 Ω
Operator control unit	9.5 ± 0.5 Ω	36 ± 1.8 Ω
Set value potentiometer	1750 - 2180 ± 80 Ω	1750 - 2180 ± 80 Ω

COMPONENT

Overheat $\sim 60\text{K}\Omega$ at room temp
 Flame sensor $\sim 1.0\text{K}\Omega$ at room temp

SWITCH VALUE

COMPONENT

Overheating sensor

AIRTRONIC D2 / D4

140°C - 170°C
 (284°F - 338°F)
 measured in the control stage "power" and at a clearance of 300 mm from the hot air outlet

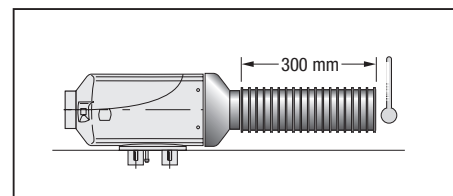

Figure 21

EXHAUST VALUE

CO² in exhaust in control stage "high"

AIRTRONIC D2 / D4

7.5 -12.5 Vol. %

<4

Soot number as per Bacharach



5 SERVICE INFORMATION

REVISION LEVEL A - 09/09/15

REPAIR INSTRUCTIONS

- Removing the cover
- Removing and checking the control unit
- Removing the glow pin
- Removing the lining
- Removing and checking the overheat and flame sensor
- Installing the overheat and flame sensor
- Dismantling the heat exchanger
- Removing the combustion air blower
- Removing the combustion chamber

PLEASE NOTE! The cover must always be removed from the *AIRTRONIC* for all repair stages. You may have to wait for the device to cool down.

REMOVING THE COVER FROM THE *AIRTRONIC*

Unlock both seal plates, lift cover and pull to the front.
The cable harness can exit from the left or right of heater shell.

- Cover ①
- Seal Plates ②

REMOVING THE CONTROL UNIT

Remove the *AIRTRONIC* cover.
Unscrew fastening screw, press retaining brackets together, lift out ECU. Unclip the lines from the holder of the control unit (observe the positions of the lines). Remove the bushing (lower part) from the outer case. Disconnect the control unit from the controller. The ECU can now be removed.

PLEASE NOTE! When reassembling the ECU, ensure that the lines are correctly clipped in the holder of the ECU, and that the connectors are plugged into the ECU (non-interchangeable).

- Fastening screw ①
- Retaining brackets ②
- ECU ③
- Bushing ④

PLEASE NOTE! Remove power from the heater prior to any disassembly by unplugging main connection or removing main fuse. If gasket was removed during disassembly, replace it when reassembling. Clean all parts before reassembly and check for any signs of damage, replace where necessary.

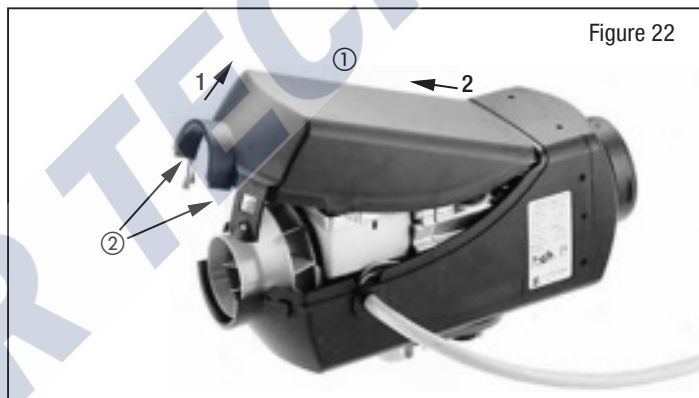

Figure 22

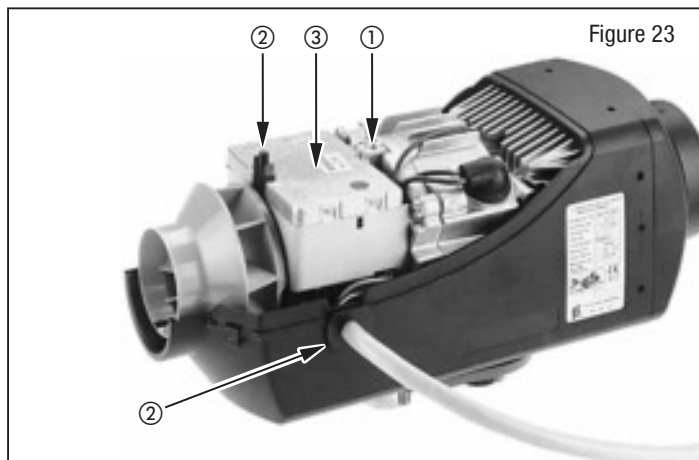

Figure 23

5 SERVICE INFORMATION

REVISION LEVEL A - 09/09/15

RECOMMENDED PERIODIC MAINTENANCE

- Remove the AIRTRONIC cover.
- Remove the ECU.

Disconnect the connector of the glow pin cable harness from the ECU.

Remove the rubber grommet and use the special tool to unscrew the glow pin.

The special tool is included with the glow pin.*

Tighten torque of the glow pin: 6 ^{+0.5} Nm (50 in•lb)

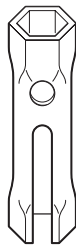

PLEASE NOTE! Please check product catalogue for more information.

PLEASE NOTE! When the glow pin has been removed, check the screen of the support in installed state for any contamination. The screen must be replaced if the surface is covered with carbon.

- Glow pin ①
- Connector of glow pin cable harness ②
- Rubber bushing ③

REMOVING THE SCREEN

Pull the screen out of the support with pointed pliers. Blow out the support with compressed air.

If necessary, carefully pierce with a wire.

The special tool has to be used to install the screen. The special tool is included with the screen. Push the screen onto the special tool, watching the position of the recess. The recess must be positioned at right angles (90°) to the axis of the heater.

Newer screens do not have a recess.

Push the tool with the screen carefully as far as it will go, ensuring that the bore (∅ 2.7 mm) for the glow plug ventilation is free. See illustration 1.

In case of the shorter, new style screen (see image B) the position of the screen to the vent hole has no reference. Ensure installation tool is completely seated when installing screen.

Image A



- ① Special tool
- ② Position of recess

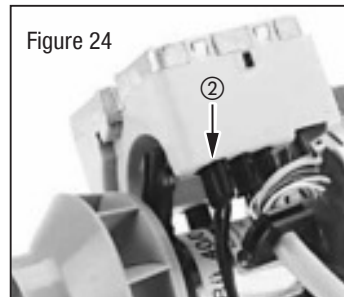

Figure 24

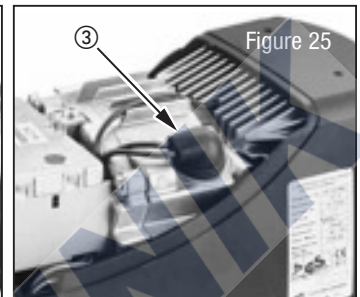

Figure 25

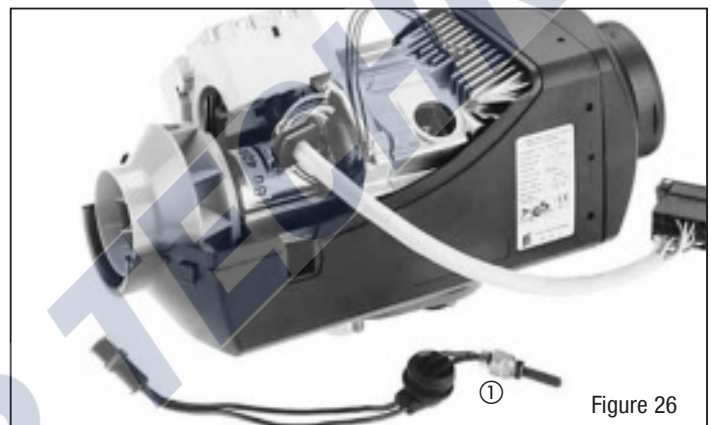

Figure 26

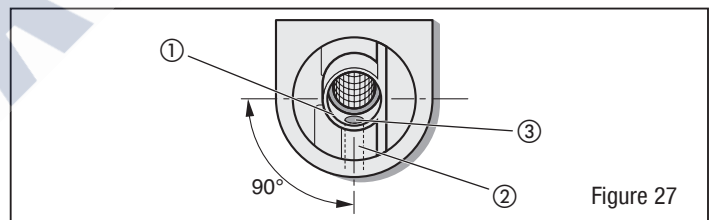
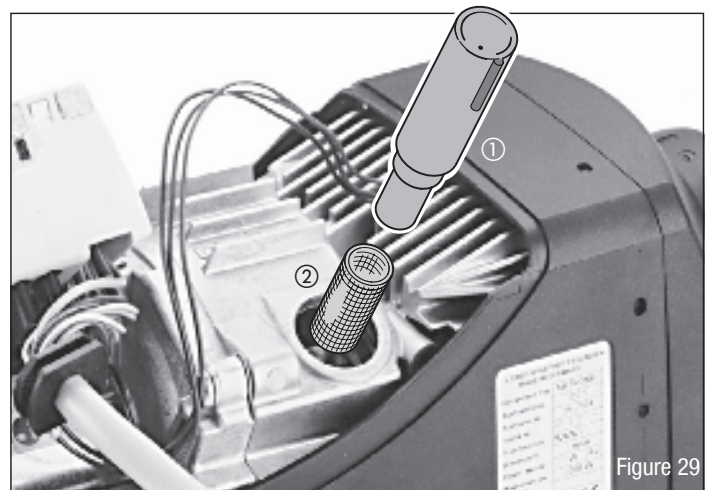

Figure 27

- ① Screen
 - ② Bore (∅ 2.7 mm) for glow pin ventilation
 - ③ Vent Hole (Can be cleaned with wire)
- Allow riveted section to be placed in such a way as to not block the vent more.

Image B



- ① Special tool
- ② Screen



5 SERVICE INFORMATION

REVISION LEVEL A - 09/09/15

REMOVING THE OVERHEAT SENSOR / FLAME SENSOR

- Remove the AIRTRONIC cover.
- Remove the control unit.

Disconnect both connectors of the overheating / flame sensor cable harness from the ECU.

Unlock clip from sensor.

Remove overheat / flame sensor.

OVERHEAT SENSOR

Check the overheat sensor with a digital multimeter. If the resistance value is outside the set point indicated in the values, on pg. 26 then the sensor must be replaced.

FLAME SENSOR

Check the flame sensor with a digital multimeter. If the resistance value is outside the set point indicated by the values table on pg. 26, then the sensor must be replaced.

INSTALLING THE OVERHEAT SENSOR / FLAME SENSOR

For AIRTRONIC D2 (Assembly using purpose made tool) mount the special tool on the sensor.

Place the sensor on the heat exchanger using the special tool.

The special tool slides on the heat exchanger until the sensor meets the collar (installation site of the sensor).

Lock the sensor in place and remove the purpose made tool.

It is then vital to check that the sensor sits flat on the heat exchanger. If necessary use a mirror and lamp to aid correct assembly.

Route the cable harness sensor along the clip eyelet to the control unit and connect.

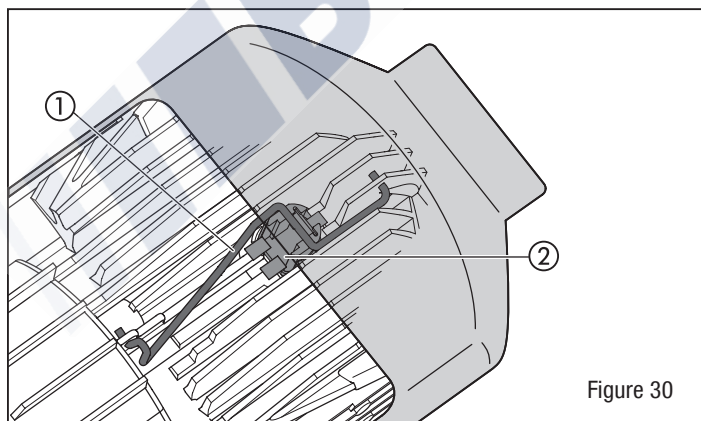
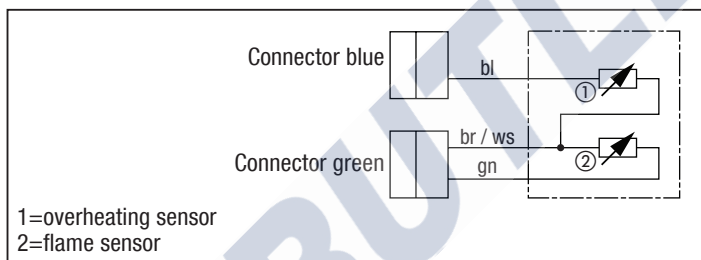

Figure 30

- ① Clip
- ② Overheat sensor / flame sensor

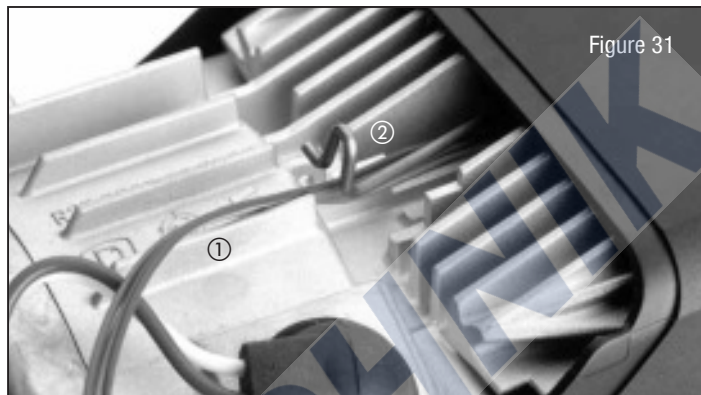

Figure 31

- ① Cable harness for overheat/flame sensor
- ② clip

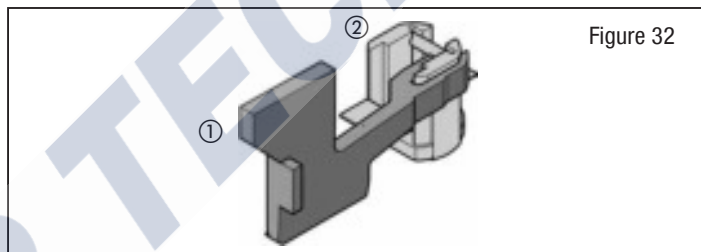

Figure 32

- ① Special tool - only for AIRTRONIC D2
- ② Overheat sensor / flame sensor

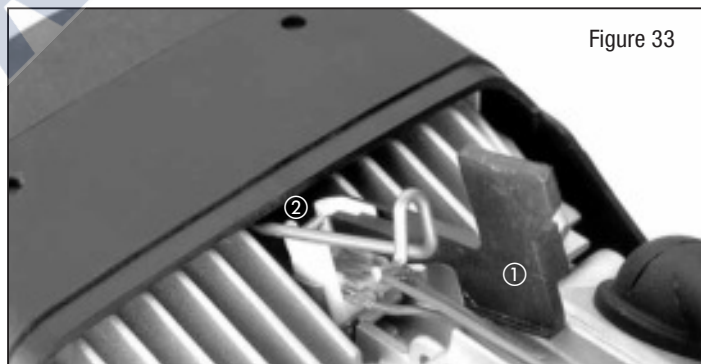

Figure 33

- ① Special tool - only for AIRTRONIC D2
- ② Overheat sensor / flame sensor

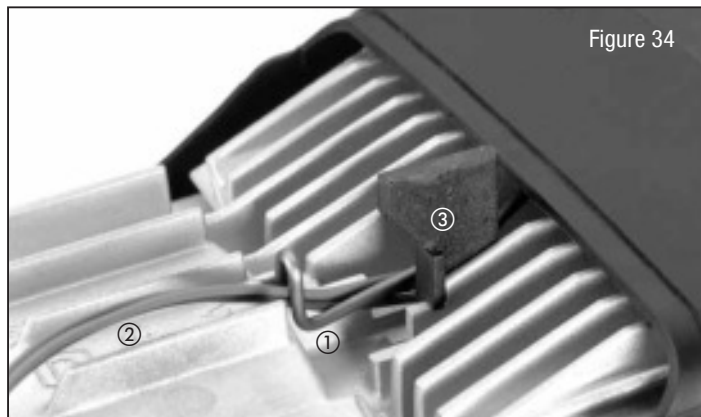

Figure 34

- ① Clip
- ② Cable harness - overheat/ flame sensor
- ③ Special tool - only necessary for the AIRTRONIC D2

5 SERVICE INFORMATION

REVISION LEVEL A - 09/09/15

DISMANTLING THE HEAT EXCHANGER REMOVING THE COMBUSTION AIR BLOWER

- Remove the AIRTRONIC cover.
- Remove the ECU.

Remove the gasket.
Take the AIRTRONIC out of the outer case (lower part).
Unscrew the 4 fastening screws from the combustion air blower.
Remove the combustion air blower and the seal from the heat exchanger.

PLEASE NOTE! When reassembling the combustion air blower, a new gasket is always required.

Tighten the 4 fastening screws of the combustion air blower in the series shown in the drawing, with a tightening torque of $4^{+0.5}$ Nm. (35 in•lb)

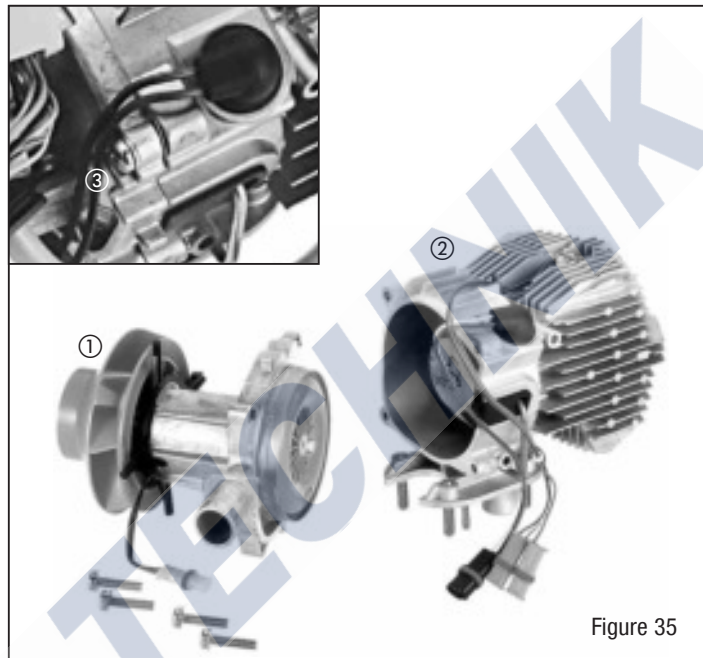
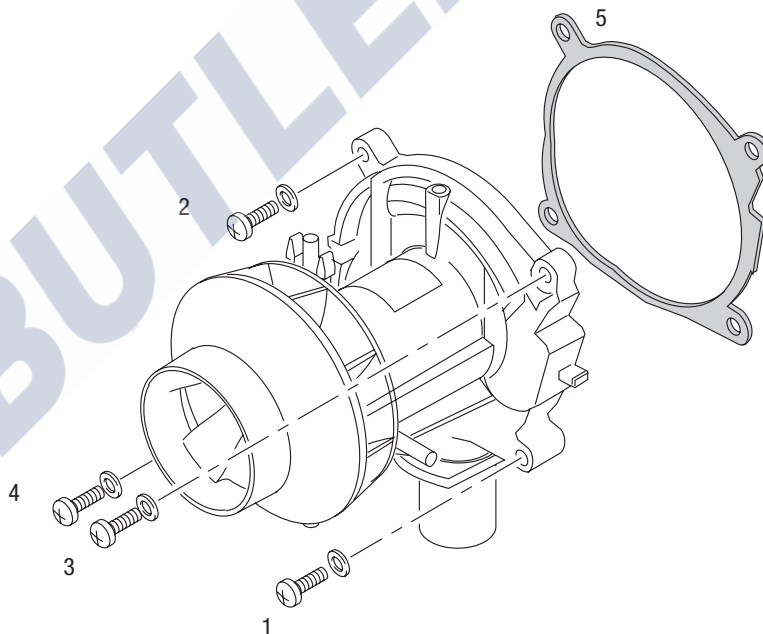

Figure 35

- ① Combustion Air blower
- ② Heat Exchanger
- ③ Fastening screws

Figure 36



- 1 - 4 Tighten the fastening screws in this sequence with a tightening torque of $4^{+0.5}$ Nm (35in•lb)
- 5 Always replace the seal between combustion air blower and heat exchanger.



5 SERVICE INFORMATION

REVISION LEVEL A - 09/09/15

REMOVING THE COMBUSTION CHAMBER

- Remove the AIRTRONIC cover.

Remove the flange seal.

Take the AIRTRONIC out of the outer case (lower part).

- Remove ECU (see previous pages).
- Remove glow pin (see previous pages).
- Remove combustion air blower (see previous pages).

Unscrew the fastening screws.

For AIRTRONIC D2 = 3 fastening screws

For AIRTRONIC D4 = 4 fastening screws

Pull the combustion burner out to the front and remove the burner's thermal insulator from the heat exchanger.

PLEASE NOTE! When reassembling the combustion burner, the thermal insulator, must always be replaced.

Tighten the self tapping fastening screws of the combustion chamber with a torque of 5 ^{+0.5} Nm. (44 in•lb)

PLEASE NOTE! If the heat exchanger is being replaced, the overheat/flame sensor must be dismantled and mounted to the new heat exchanger (see previous pages).

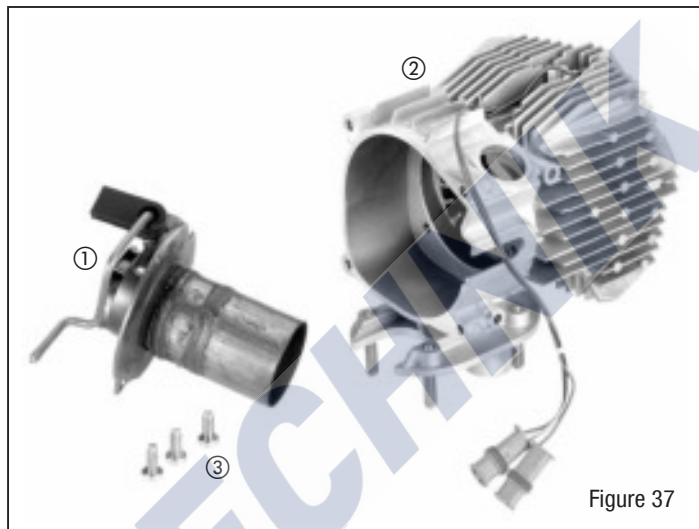
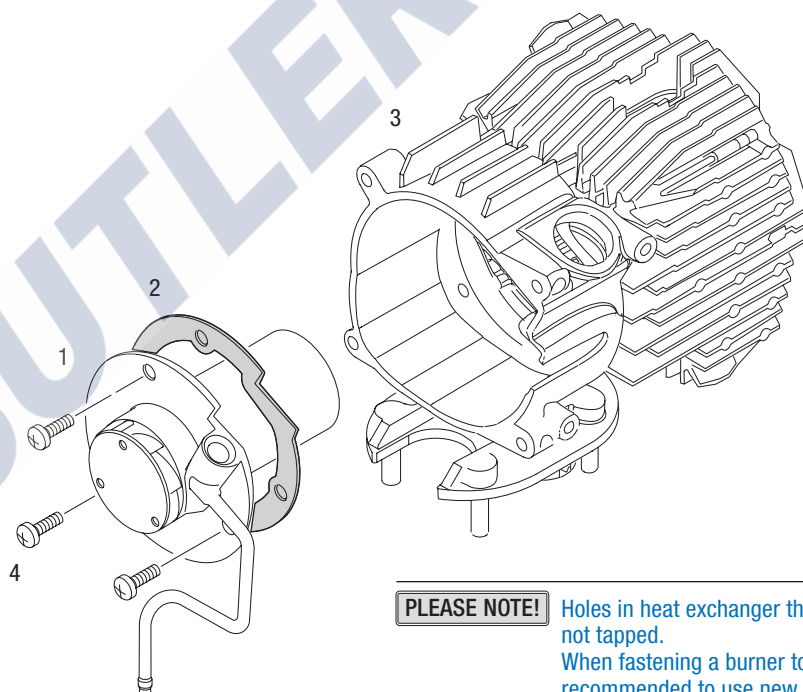

Figure 37

- ① Combustion burner
- ② Heat Exchanger
- ③ Fastening screws
AIRTRONIC D2 = 3 fastening screws
AIRTRONIC D4 = 4 fastening screws

Figure 38



PLEASE NOTE! Holes in heat exchanger that fasten the burner tube are not tapped.
When fastening a burner to a new heat exchanger it is recommended to use new screws.

- 1 Combustion burner
- 2 Thermal insulator between combustion burner and heat exchanger, must always be replaced if burner is removed from the heat exchanger.
(Holes not threaded)
- 3 Heat exchanger
- 4 Self tapping fastening screws.
AIRTRONIC D2 = 3 fastening screws
AIRTRONIC D4 = 4 fastening screws

6 PARTS BREAKDOWN

REVISION LEVEL A - 09/09/15

AIRTRONIC D2 / /D3 / B /D4
SERVICE PARTS DIAGRAM

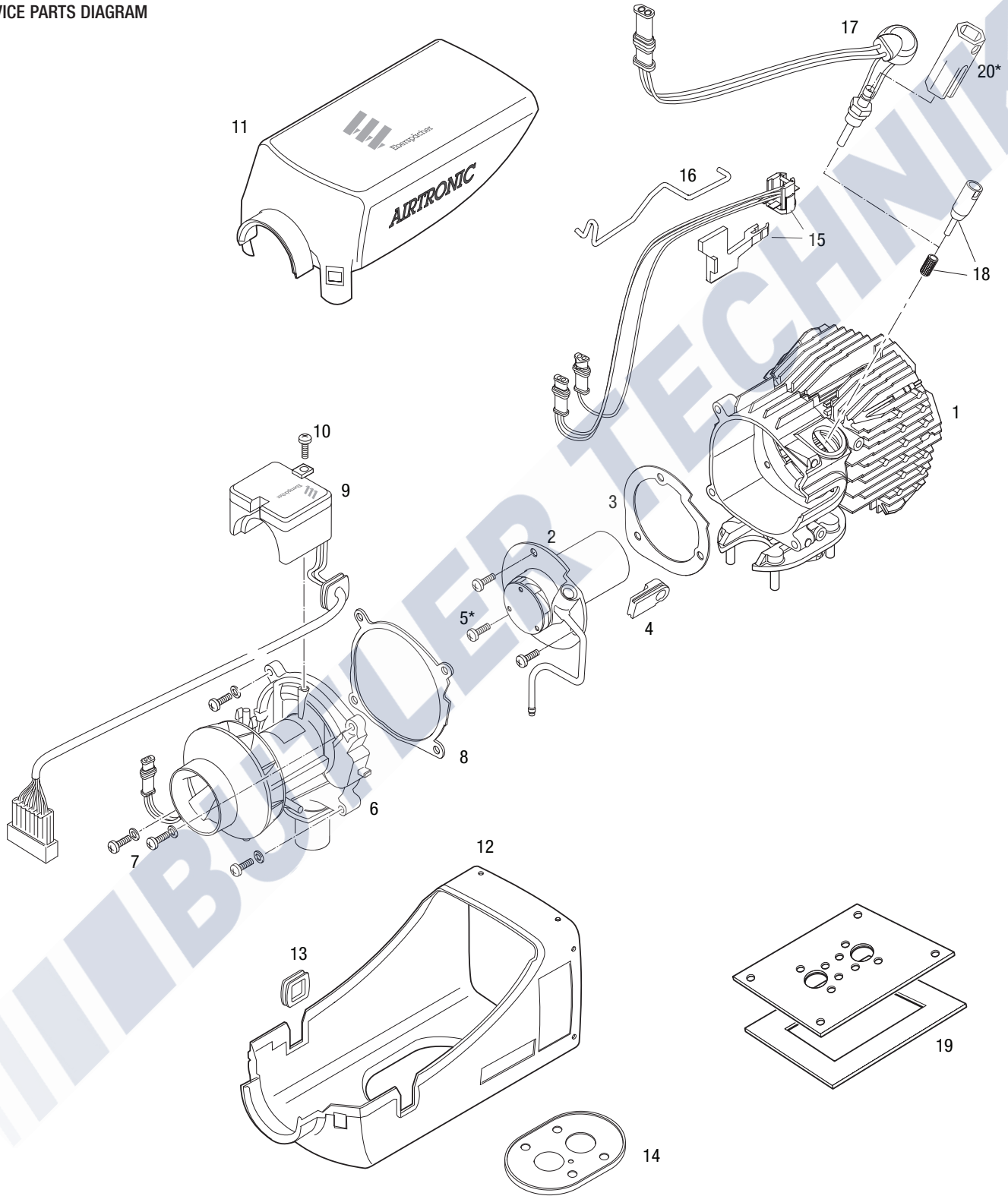



6 PARTS BREAKDOWN

AIRTRONIC D2 / B / D4

DESCRIPTION & PART #'S

Ref. No. Description

Part Number

Model #

20 1812 05 12V	25 2069 05 12V	25 2070 05 24V	25 2326 05 12V	25 2327 05 12V	25 2113 05 12V	25 2114 05 24V	25 2144 05 12V
----------------	----------------	----------------	----------------	----------------	----------------	----------------	----------------

Ref. No.	Description	Part Number	20 1812 05 12V	25 2069 05 12V	25 2070 05 24V	25 2326 05 12V	25 2327 05 12V	25 2113 05 12V	25 2114 05 24V	25 2144 05 12V
1	Heat exchanger	25 2069 06 01 00	•	•	•	•				
		25 2113 06 01 00	•				•	•	•	•
2	Burner	25 2069 10 01 00		•	•	•				
		25 2113 10 01 00					•	•	•	•
		20 1812 10 01 00	•							
3	Thermal insulator for burner	25 2069 06 00 01		•	•	•				
		25 2113 06 00 01		•			•	•	•	•
4	Grommet	25 2069 06 00 02	•	•	•	•	•	•	•	•
5	Fillister head bolt, M 5 x 12 (3 required)	103 10 348	•	•	•	•				
		Fillister head bolt, M 5 x 12 (4 required)	103 10 348	•			•	•	•	•
6	Blower motor	12V 25 2069 99 20 00		•		•				
		24V 25 2070 99 20 00			•					
		12V 25 2113 99 20 00		•			•			
		24V 25 2114 99 20 00						•		
		12V 25 2144 99 20 00							•	•
7	Fillister head bolt, M 5 x 25	Locally available hardware	•	•	•	•	•	•	•	•
8	Gasket, blower	25 2069 01 00 03		•	•	•				
		25 2113 01 00 03		•			•	•	•	•
9	Control unit	24V 22 5102 00 10 01			•					
		12V 22 5101 00 10 05					•			
		24V 22 5102 00 10 03						•		
		12V 22 5101 00 10 06							•	
		12V 22 5101 00 10 13				•				
		12V 22 5101 00 10 14								•
		Hella 12V 22 5101 00 30 01			•					
		Hella 12V 22 5101 00 30 05						•		
22 5101 00 30 15		•								
10	Fillister head bolt, M 4 x 10	103 10 349	•	•	•	•	•	•	•	•
11	Upper casing	25 2069 01 06 00		•	•	•				
12	Lower casing	25 2113 01 00 01		•			•	•	•	•
		25 2069 01 01 00		•	•	•				
13	Grommet	25 2113 01 01 00		•			•	•	•	•
		25 2069 01 00 01		•	•	•	•	•	•	•
14	Flange seal	25 2069 01 00 02		•	•	•	•	•	•	
15	Overheat sensor / Flame sensor with tool	25 2069 01 02 00		•	•	•	•	•	•	
16	Clip	25 2069 01 02 02		•	•	•	•	•	•	•
		25 2113 01 02 02		•			•	•	•	•
17	Glow pin with socket wrench	12V 25 2069 01 13 00		•	•	•	•	•	•	•
		24V 25 2070 01 11 00			•			•		
18	Glow pin screen with tool	25 2069 10 01 02		•	•	•	•	•	•	
19	Mounting plate with hardware and seal	5540001		•	•	•	•	•	•	
20	Glow pin wrench *	25 2069 01 03 03		•	•	•	•	•	•	

* This tool is designed for occasional usage. If heavy use is anticipated, more appropriate tools are available from tool manufacturers.

Recommended: Snap-On Flare nut socket 12mm Stock # FRXM12

6 PARTS BREAKDOWN

REVISION LEVEL A - 09/09/15

AIRTRONIC D2 / D3 / B / D4
SERVICE PARTS DIAGRAM

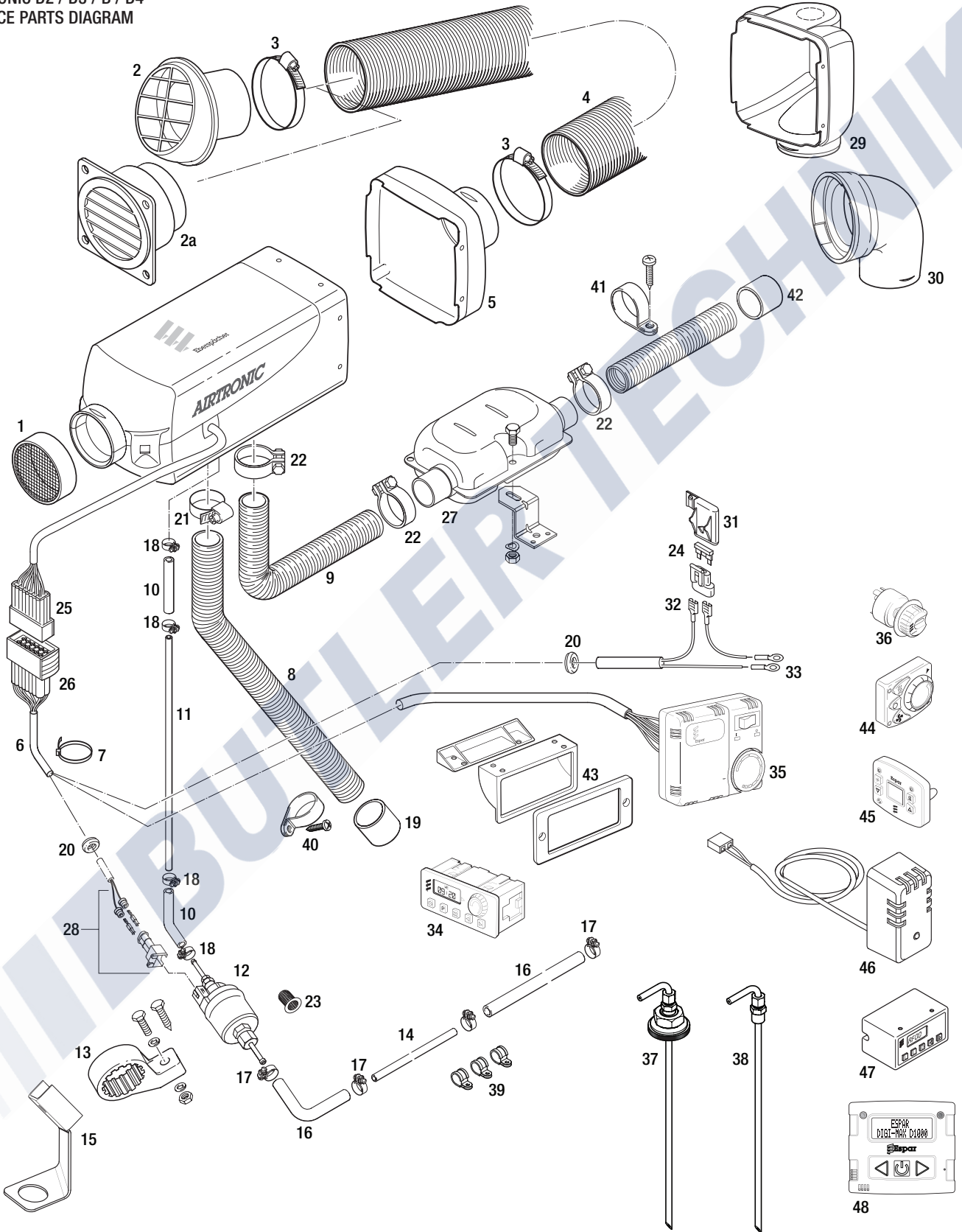



6 PARTS BREAKDOWN

AIRTRONIC D2 / B / D4				Model #	20 1812 05 12V	25 2069 05 12V	25 2070 05 24V	25 2326 05 12V	25 2327 05 12V	25 2113 05 12V	25 2114 05 24V	25 2144 05 12V
Ref. No.	Description		Part Number									
1	Safety screen	ø 60	25 1688 80 06 00		•	•	•	•	•	•	•	•
		ø 75	25 1552 05 01 00		•							
2	Warm air deflector	ø 60	20 2800 50 02 00		•	•	•	•	•	•	•	•
2a		ø 90	20 1609 80 09 00		•							
		ø75	22 1050 89 21 00									
3	Clamp	ø 50-70	5550004		•	•	•	•	•	•	•	•
		ø 70-90	5550003		•							
4	Flexible air hose	ø 60	10 2114 31 00 00		•	•	•	•	•	•	•	•
		ø 90	10 2114 37 00 00		•							
		ø 75	10 2114 34 00 00		•							
5	Straight outlet hood	ø 60	22 1000 01 00 16		•	•	•	•	•	•	•	•
		ø 90	22 1000 01 00 19		•							
		ø 75	22 1000 01 00 18		•							
6	Main harness		20 2900 70 03 91		•	•	•	•	•	•	•	•
	Short harness		20 2900 70 02 05		•	•	•	•	•	•	•	•
7	Cable ties (197mm)		5590003		•	•	•	•	•	•	•	•
8	Air intake (1 meter)	ø25 mm	360 00 006		•	•	•	•	•	•	•	•
9	Flexible exhaust (1 meter)	ø24 mm	25 1774 80 02 00		•	•	•	•	•	•	•	•
10	Fuel hose - rubber 3.5 mm		360 75 300		•	•	•	•	•	•	•	•
11	Plastic fuel line 1.5 mm		890 31 125		•	•	•	•	•	•	•	•
12	Fuel metering pump	12V	22 4519 01 00 00		•	•	•	•	•	•	•	•
		24V	22 4518 01 00 00				•					
13	Clamp for fuel metering pump		22 1000 50 03 00		•	•	•	•	•	•	•	•
14	Plastic fuel line - black	2 mm	890 31 125		•	•	•	•	•	•	•	•
15	Angle bracket		20 2900 40 0104		•	•	•	•	•	•	•	•
16	Fuel hose - rubber 5 mm		360 75 350		•	•	•	•	•	•	•	•
17	Clamp	11 mm	10 2068 01 10 98		•	•	•	•	•	•	•	•
18	Clamp	9 mm	10 2068 00 90 98		•	•	•	•	•	•	•	•
19	End sleeve with cross bar - 25mm plastic		25 1729 89 00 02		•	•	•	•	•	•	•	•
20	Grommet		20 1280 09 01 03		•	•	•	•	•	•	•	•
21	Intake hose clamp	ø 20-32	10 2065 02 00 32		•	•	•	•	•	•	•	•
22	Clamp	26 mm	152 61 102		•	•	•	•	•	•	•	•
23	Fuel screen		20 1312 00 00 06		•	•	•	•	•	•	•	•
24	Blade fuse	20 amp	5670055		•	•	•	•	•	•	•	•
		10 amp	5670056				•					
25	Plug connector - Kit		22 1000 31 80 00		•	•	•	•	•	•	•	•
26	Housing - Kit female		22 1000 31 81 00		•	•	•	•	•	•	•	•
*27	Muffler		25 1864 81 01 00		•	•	•	•	•	•	•	•
28	Connectors for fuel metering pump - Kit		22 1000 31 87 00		•	•	•	•	•	•	•	•
*29	90° Air outlet hood	ø 60	22 1000 01 00 20		•	•	•	•	•	•	•	•
		ø 75	22 1000 01 00 22					•	•	•	•	•
		ø 90	22 1000 01 00 23					•	•	•	•	•
*30	90° Bend	ø 60	25 1688 89 00 01		•	•	•	•	•	•	•	•
		ø 75	25 1482 89 00 05		•	•	•	•	•	•	•	•
31	Fuse holder with terminals		5670051		•	•	•	•	•	•	•	•

6 PARTS BREAKDOWN

AIRTRONIC D2 / B / D4

DESCRIPTION & PART #'S

Ref. No. Description

Part Number

Model #

20 1812 05 12V
 25 2069 05 12V
 25 2070 05 24V
 25 2326 05 12V
 25 2327 05 12V
 25 2113 05 12V
 25 2114 05 24V
 25 2144 05 12V

32	Terminals		5670199	•	•	•	•	•	•	•	•
33	3/8' Ring terminals 10-12 G		5670178	•	•	•	•	•	•	•	•
*34	7 day timer		22 1000 30 40 00	•	•	•	•	•	•	•	•
35	Thermostat	12V	301 00 154	•	•	•	•	•	•	•	•
		24V	301 00 153	•	•	•	•	•	•	•	•
*36	Operating switch (rotary)	12V	25 1895 71 00 00	•	•	•	•	•	•	•	•
		24V	25 1896 71 00 00	•	•	•	•	•	•	•	•
37	Standard fuel pick up pipe	2 mm	20 2900 20 20 56	•	•	•	•	•	•	•	
* 38	Fuel pick up pipe (Compression fitting type)		20 2900 20 20 42	•	•	•	•	•	•	•	
* 38a	Compression fittings	1/4" NPT	20 2900 20 20 44	•	•	•	•	•	•	•	•
		3/8" NPT	5520002	•	•	•	•	•	•	•	•
		1/2" NPT	5520006	•	•	•	•	•	•	•	•
39	P-clamp w/Lining	10 mm	152 00 139	•	•	•	•	•	•	•	
40	P-clamp	25 mm	152 10 048	•	•	•	•	•	•	•	
41	P-clamp	28 mm	152 10 051	•	•	•	•	•	•	•	
42	End-sleeve 24 mm		25 1482 80 00 01	•	•	•	•	•	•	•	
43	Bezel kit for 7 day timer		25 1482 70 01 00	•	•	•	•	•	•	•	
44	Mini Controller		22 1000 32 07 00	•	•	•	•	•	•	•	
45	Digi Controller		20 2800 70 10 00	•	•	•	•	•	•	•	
46	Ext Temp Sensor		25 1774 89 03 00	•	•	•	•	•	•	•	
47	Fault code retrieval device		20 2900 70 50 20	•	•	•	•	•	•	•	
48	Digi-Max Controller		20 2800 70 15 00	•	•	•	•	•	•	•	

* = indicates optional features



6 CARBONING

REVISION LEVEL A - 09/09/15

EXAMPLES / CAUSES OF CARBONING

Carbon is a term used to classify debris in the burner chamber. What you may visually see may not be carbon but still needs to be addressed properly to resolve the root cause of the issue. This is just a guide to the more common things you may encounter.

1. AIR FUEL MIXTURE

- a. If the air fuel mixture is off it can cause a black soot in the burner chamber and can also be identified by looking through the heater exhaust exhaust port.
 - i. Improper angle of fuel pump.
 - ii. Wrong fuel pump used.
 - iii. Fuel pump out of calibration, perform fuel quantity test found on page 13.
 - iv. Low spots or restriction of intake tube or exhaust tube.
 - v. Debris ingested into the combustion air intake fan impeller.
 - vi. Improper length or too many bends of intake and exhaust tube
Combined maximum of 6.5' and 270° of bends.



2. NON-FUEL RELATED BUILDUP

- a. If all the steps have been covered under the section outlining code 52 and the chamber is clean looking the issue may be in the fuel or chemicals ingested by the intake tube.
 - i. If the heater intake tube is in a location to pick up road debris like water and salt it can build up in the burner matting.
 - ii. Additives are OK to use but if the concentration is in excess of the manufactures recommendations, it can build up in the burner matting.
 - iii. Oil related products like ATF or used oil will cause premature chamber failure. This practice will not be tolerated by the heater. If oil must be used it is recommended to operate your Espar heater from a separate fuel source.



3. SHORT CYCLING OF HEATER

- a. If the heater is allowed to short cycle it may cause a build-up of Creosote. Minimum runtime on a heater should be 15 minutes.
- b. Sizing of the heater is important: If it is sized too large or cycled off at too low of a coolant temperature could lead to premature burner chamber failures.
- c. Electrical connection issues: If the signal wire is sporadic, it will turn the heater on and off.
- d. Abrupt loss of main power: Can cause burner chamber failure due to loss of its cool down cycle – never use the Master Disconnect Switch to cut heater power.



7 FUEL FILTER / FUEL PUMP ANGLE

REVISION LEVEL A - 09/09/15

FUEL PUMP MAINTENANCE / PROPER MOUNTING

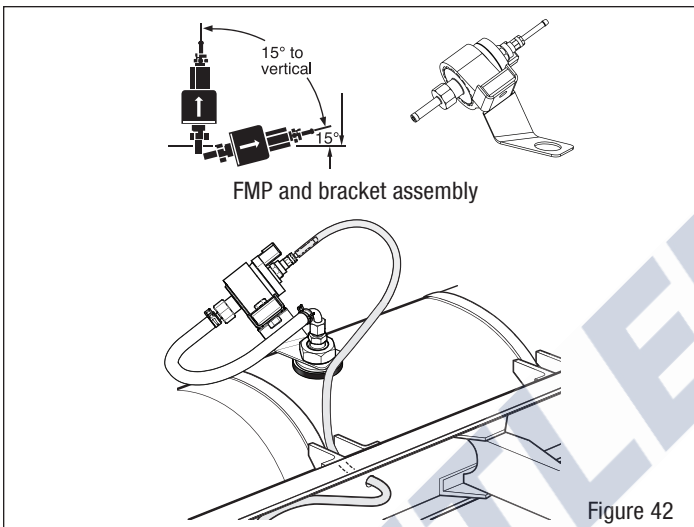
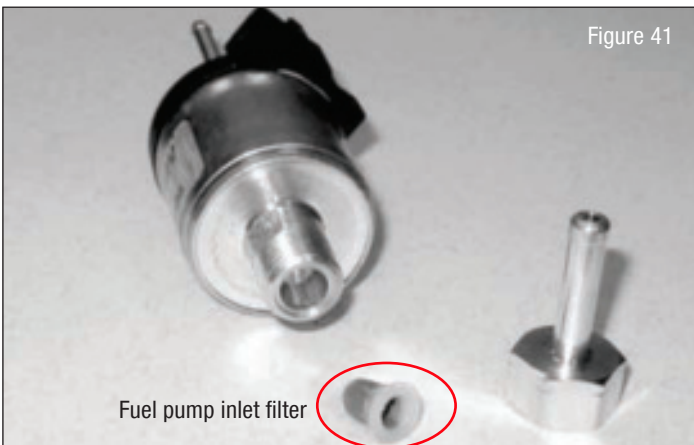

Fuel pump inlet filter – clean or replace annually, more frequently if fuel contamination is noticed. Fuel pump should be mounted at a 15-35 degree angle, harness connection / outlet side facing up.



8 DUCTING RATING GUIDE

REVISION LEVEL A - 09/09/15

GENERAL TIPS ON HEATING AIR DUCTING AND COMPONENT RATINGS

A heater has the biggest heating air throughput when it can operate with the air blowing freely. Heating air ducting components reduce the throughput. To enable you to check whether or not the installation you plan reduces the air throughput to an inadmissible degree, we have calculated a heater rating for each heater and a component rating for each heating air ducting component:

- 0 = no temperature increase
- = no component rating

The sum of component ratings for the heating air ducting components must not exceed the heater rating, otherwise the outlet temperature will become too high and trigger the safety cutout switch. If the sum of the component ratings exceeds the heater rating, it can be reduced by selecting a larger diameter for the air ducting parts.

Rule of Thumb:

Double the cross-section or two identical components running parallel = 1/4 of the rating.

Example:

50 diameter hose
A = 19.6 cm², R rating 1.0

75 diameter hose
A = 44.2 cm², R rating 0.25

The component rating of smooth welded pipes is only half that of flexible pipe of equal diameter (e.g. double the pipe length).

MAIN-LINE DRAWING FOR 1-DUCT AND 2-DUCT HEATING AIR SYSTEM

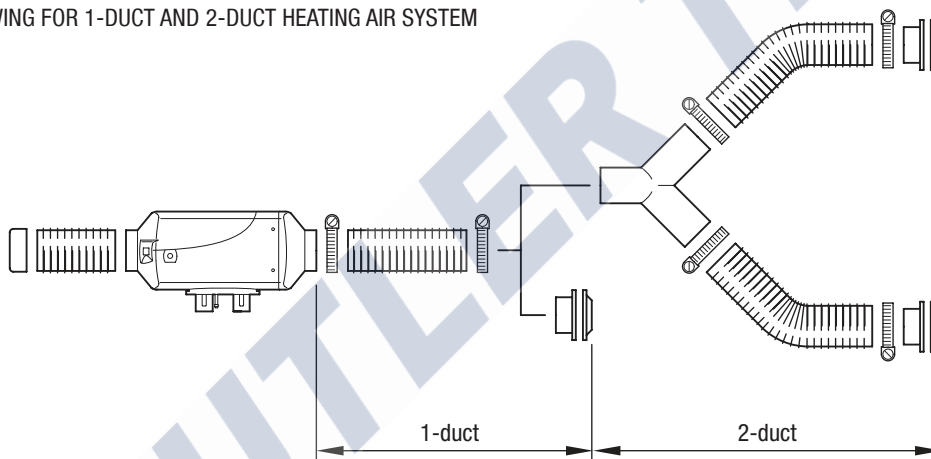

2-duct means:

The heating air line branches into two ducts after the heater. Up to the branch the component ratings under "1-duct" are valid, after the branch they fall under "2-duct". If an adjustable outlet is used in the 2-duct heating system, one duct must be unclosable.

PLEASE NOTE!

When determining the sum of the component ratings, do not take the closable duct into consideration.

1-duct means:

A heating duct leads to or from heater. The component ratings under "1-duct" are valid.

Example of Heating Air Ducting for AIRTRONIC D2

Heater Rating = 6

Item	Designation	Component Rating
1	Protective grille	0.5
2	Connection piece 60mm dia.	0
3	Flex. pipe, 60mm dia. 0.3m long	0.3
4	Flex. pipe, 60mm dia. 1.0m long	1.0
5	Reduction hood 60mm straight	0
6	1 x 90° bends of flex. pipe	0.2
7	Swivel outlet	3.2
Total	Component Rating	5.2

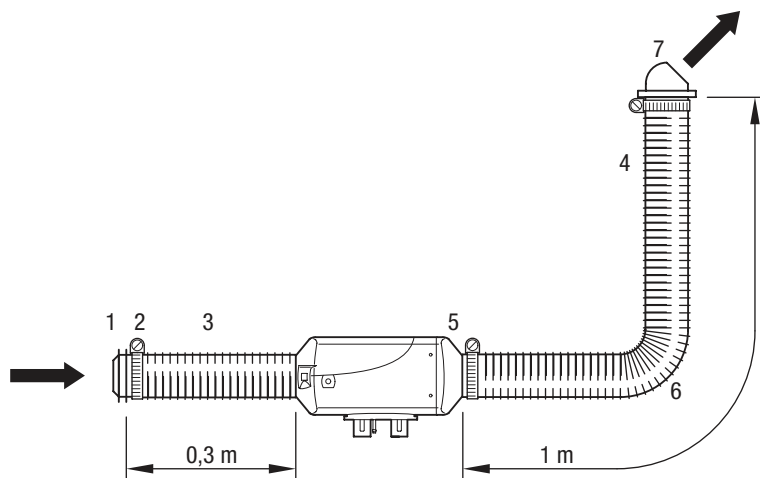

Rating sum = 5.2 and does not exceed the heater rating of 6. The installation is permissible.

8 DUCTING RATING GUIDE

REVISION LEVEL A - 09/09/15

DUCTING RATING GUIDE FOR AIRTONIC D2

Heater Rating 6 - applies with a 60mm dia. outlet hood.
Heater Rating 12 - applies with a 75mm dia. outlet hood

The sketch shows how the most important air ducting parts that can be used. They are not intended as examples of installation.

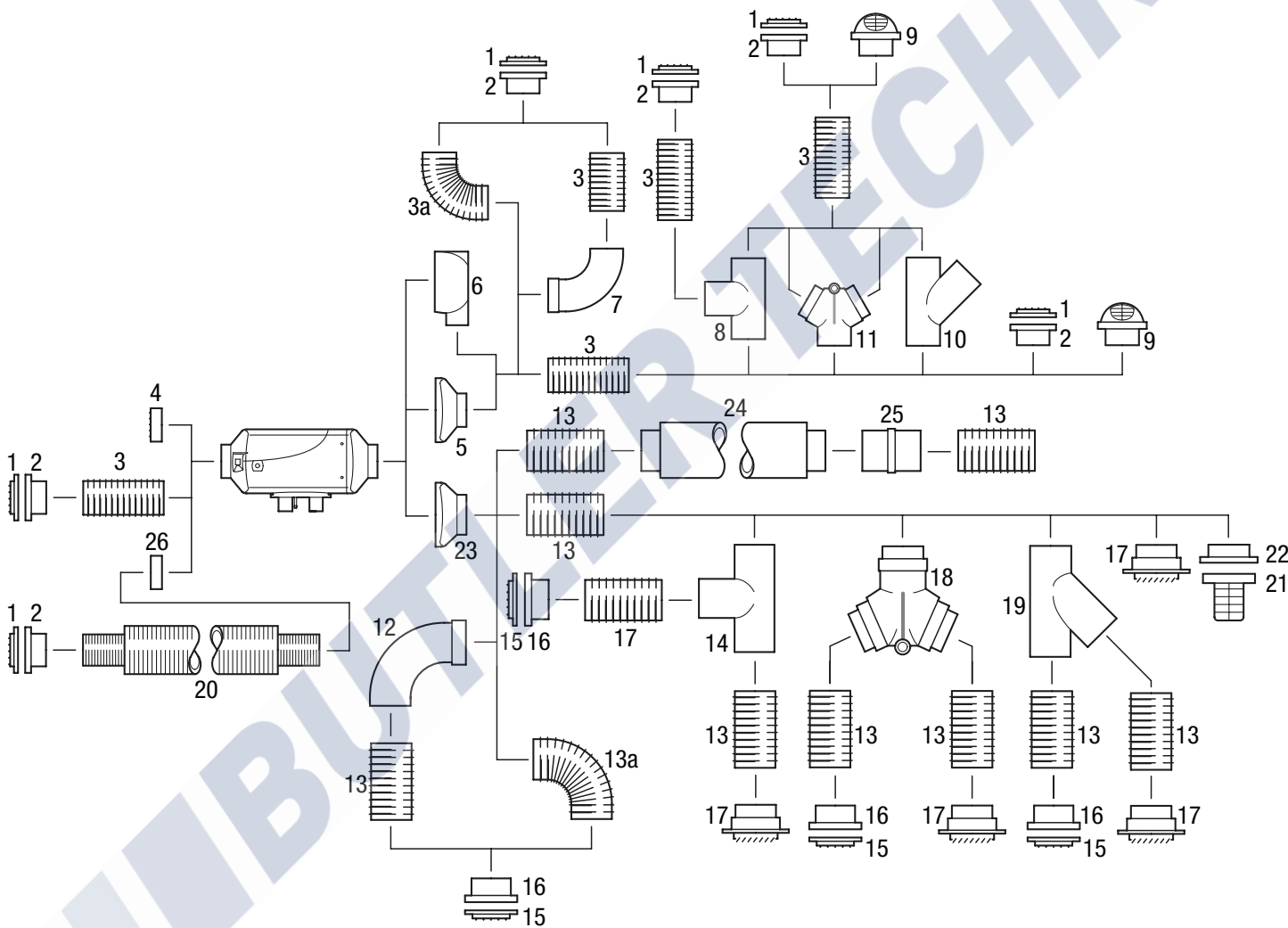



8 DUCTING RATING GUIDE

REVISION LEVEL A - 09/09/15

DUCTING RATING GUIDE FOR AIRTRONIC D2

	DESIGNATION (measurements in millimeters)	COMPONENT RATING	
		1-duct	2-duct
	Heating air ducting with reduction hood 60 dia. (heater rating 6)		
1	Grille	0.5	0.1
2	connecting socket, plastic	0	0
3	Flexible pipe, 60 dia. per m	1	0.25
3a	90° pipe bend of flex. pip, 60 dia.	0.2	-
4	Protective grille	0	-
5	Reduction hood, 60 dia.	0	0
6	Spherical reduction hood, 60 dia.	4.8	-
7	90° pipe bend	4	-
8	T-piece	1.4	0.25
9	Outlet grill 60 dia. (rotatable)	3.2	0.8
10	Y-piece - 1		
11	Regulating valve 60x60x60 dia. with flap Position "middle" Position "right/left"	- -	- 0.6
	Heating air ducting with reduction hood 75 dia. (heater rating 12)		
12	Pipe bend, 75 dia.	4.5	-
13	Flexible pipe, 75 dia. per m	1	0.25
13a	90° pipe bend of flex. pipe, 75 dia.	1.2	-
14	T-piece 75x75x75 dia.	-	0.8
15	Grille, 75 dia.	0.6	0.1
16	Connecting socket, metal, 75 dia.	0	0
17	Outlet grill (rotatable)	0.6	0.2
18	Regulating valve 75x75x75 dia. with flap Position "middle" Position "right/left"	0	1.2
19	Y-piece 75x75x75 dia.	-	0.6
20	Intake silencer, 75 dia.	0.7	-
21	Outlet grill with	0.8	0.15
22	Connecting socket, plastic, 75 dia.	0	0
23	Reduction hood, 75 dia.	0	0
24	Silencer, 75 dia.	0.6	-
25	Connector, 75 dia.	0.5	0.1
26	Ring, 60x75 dia.	-	-

8 DUCTING RATING GUIDE

REVISION LEVEL A - 09/09/15

DUCTING RATING GUIDE FOR AIRTONIC D4

Heater Rating 3 - applies with a 75mm dia. outlet hood.
Heater Rating 10 - applies with a 90mm dia. outlet hood.

The sketch shows how the most important air ducting parts that can be used. They are not intended as examples of installation.

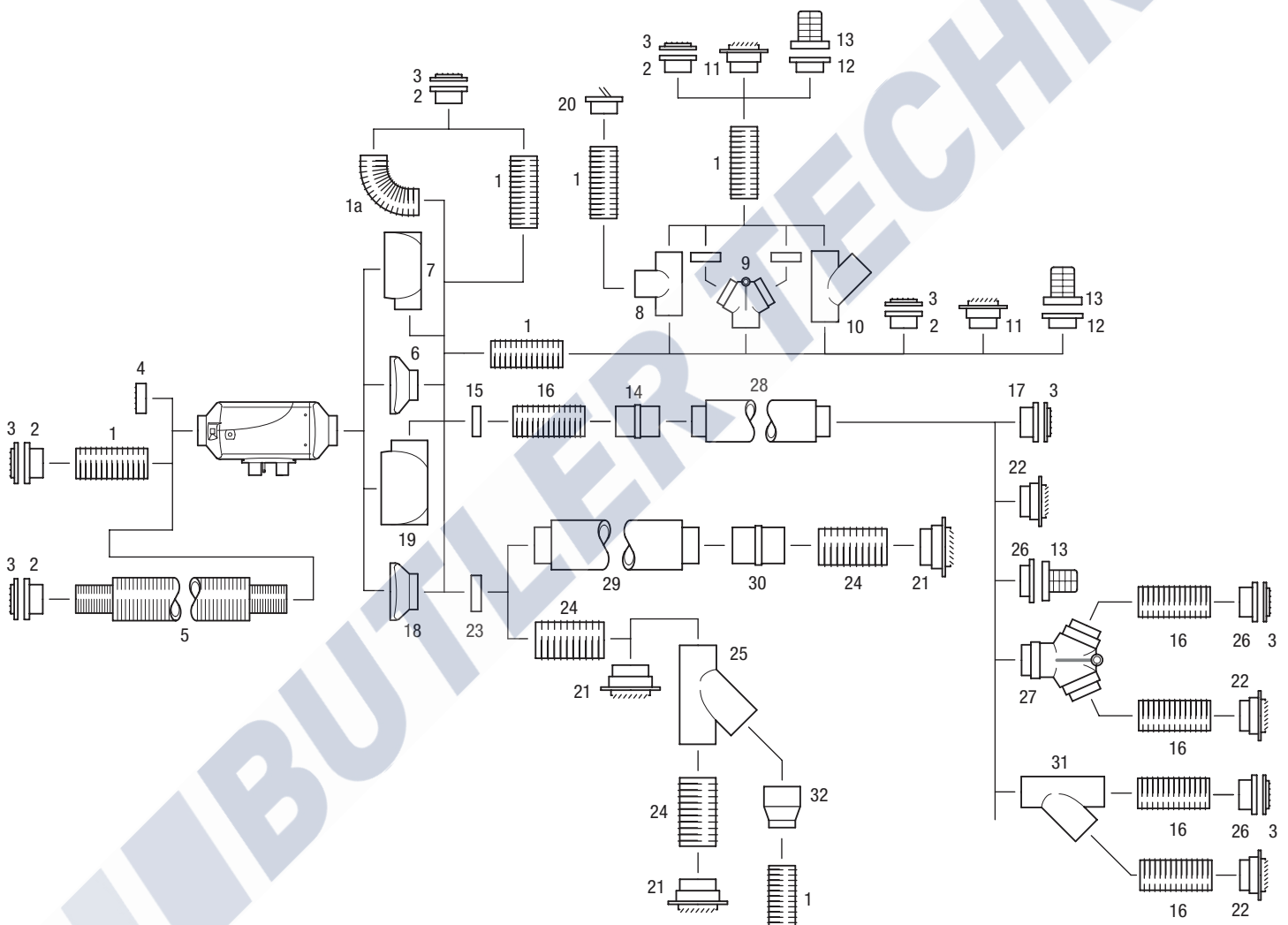



8 DUCTING RATING GUIDE

REVISION LEVEL A - 09/09/15

DUCTING RATING GUIDE FOR AIRTRONIC D4

	DESIGNATION (measurements in millimeters)	COMPONENT RATING			
		1-duct		2-duct	
		75	90	75	90
	Heating air ducting with reduction hood 75 dia. (heater rating 3)				
	Heating air ducting with reduction hood 90 dia. (heater rating 10)	75	90	75	90
1	Flexible pipe, 75 dia. per m	1	-	0.2	-
1a	90° pipe bend of flex. pipe, 75 dia.	0.2	-	-	-
2	Connecting socket, metal, 75 dia.	0.0	-	0.0	-
3	Grille	0.4	0.1	0.1	0.03
4	Grille, 75 dia.	2.0	-	-	-
5	Intake silencer, 75 dia.	0.8	-	-	-
6	Reduction hood, 75 dia.	0	-	-	-
7	Spherical reduction hood, 75 dia.	0.8	-	-	-
8	T-piece 75x75x75 dia.	-	-	0.5	-
9	Regulating valve 75x75x75 dia. with flap	-	-	-	-
	Position "middle"	-	-	-	-
	Position "right/left"	-	-	1.8	-
10	Branch piece 75x75x75 dia.	-	-	0.6	-
11	Outlet grill (rotatable) 75 dia.	0.8	-	0.2	-
12	Connector, 75 dia.	0	-	0	-
13	Outlet grill	1.1	-	0.3	-
14	Connector, 75 dia.	-	0.5	-	0.1
15	Ring, 75x90 dia.	0.5	-	-	-
16	Flexible pipe, 90 dia. per m	-	1	-	0.25
17	Connector socket, 90 dia. with grille	-	0	-	0
18	Reduction hood, 90 dia.	-	0	-	-
19	Spherical reduction hood, 90 dia.	-	5	-	-
20	Round outlet, 75 dia.	-	-	-	-
21	Outlet grill (rotatable) 100 dia.	-	2.1	-	0.5
22	Outlet grill (rotatable) 90 dia.	-	2.2	-	0.5
23*	Grille, round, 90x100 dia.	-	0	-	-
24	Flexible pipe, 100 dia. per m	-	0.4	-	-
25	Y-piece 100x100x100 dia.	-	-	-	0.5
26	Connector, 90 dia., with exhauster pos. 13	-	-	-	0
27	Regulating valve 90x90x90 dia.	-	-	-	-
	Position "middle"	-	1.2	-	-
	Position "right/left"	-	1.4	-	-
28	Silencer, 90 dia.	-	0.7	-	-
29	Silencer, 100 dia.	-	0.5	-	-
30	Connector, 100 dia.	-	0.1	-	-
31	Y-piece 90x90x90 dia.	-	-	-	0.3
32	Reduction piece, 100 dia. - 75 dia.	-	-	-	0.8

* Pos. 23 - if used as adapter 90x100 dia., cut out the mesh.

8 DUCTING RATING GUIDE

REVISION LEVEL A - 09/09/15

DUCTING RATING GUIDE FOR B1LC COMPACT

Heater Rating 6 - applies with a 60mm dia. outlet hood.

Heater Rating 15 - applies with a 75mm dia. outlet hood.

The sketch shows how the most important air ducting parts that can be used. They are not intended as examples of installation.

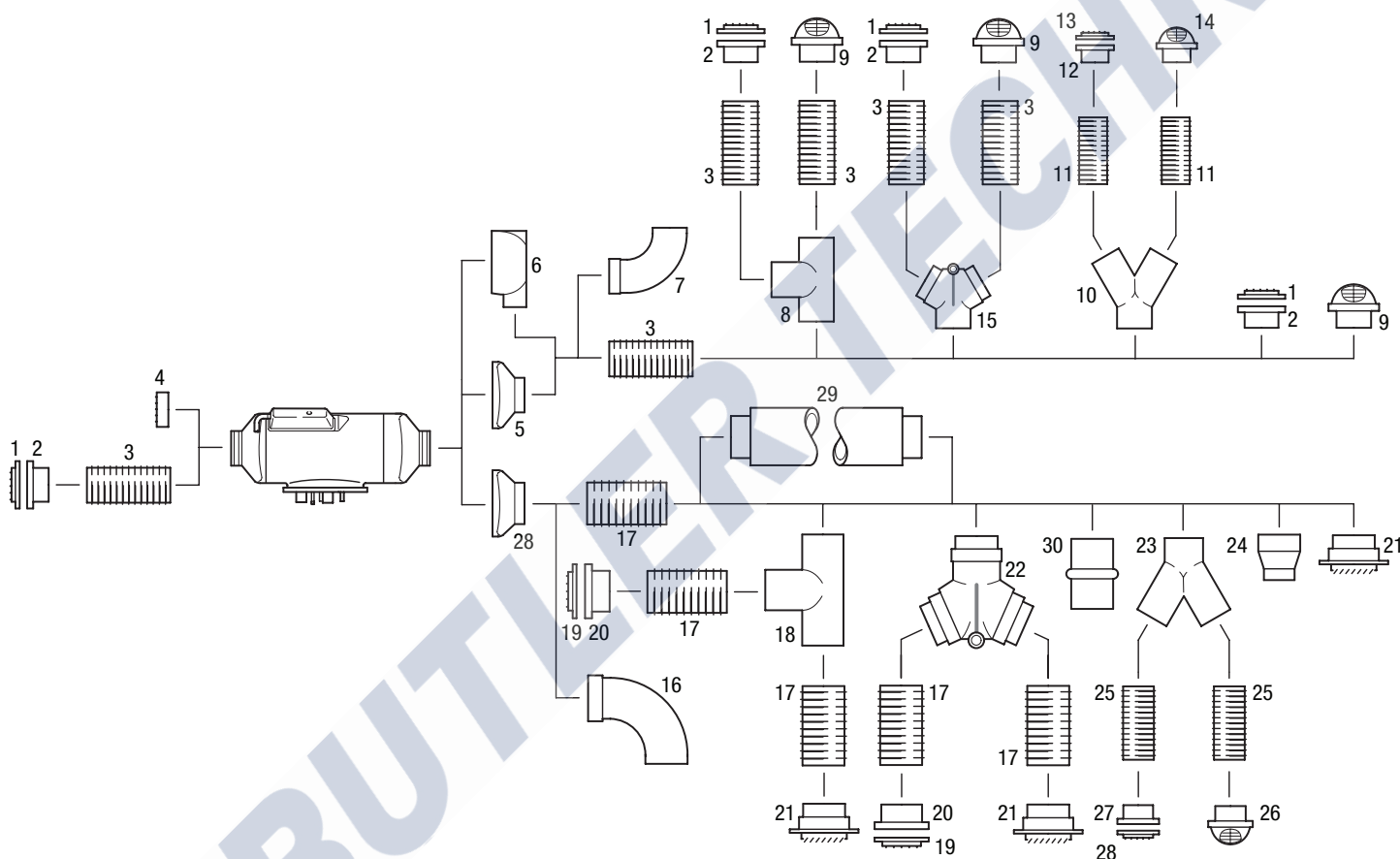



8 DUCTING RATING GUIDE

REVISION LEVEL A - 09/09/15

DUCTING RATING GUIDE FOR B1LC COMPACT

	DESIGNATION (measurements in millimeters)	COMPONENT RATING	
		1-duct	2-duct
	Heating air ducting with reduction hood 60 dia. (heater rating 6)		
1	Grille	1.2	0.4
2	Connecting socket, plastic	0.3	0
3	Flexible pipe, 60 dia. per m	1	0.25
-	90° pipe bend of flex. pipe, 60 dia.	0.5	0.1
4	Protective grille	0.15	-
5	Reduction hood 60 dia.	0	0
6	Spherical reduction hood, 60 dia.	1.7	1.7*
7	Pipe bend, 60 dia.	3	*
8	T-piece, 60 dia.	-	0.3
9	Outlet grill (rotatable) 60 dia.	1	0.25
10	Y-piece, 60 dia.	-	0.85
11	Flexible pipe, 50 dia. per m	-	0.25
-	90° pipe bend of flex. pipe, 50 dia.	-	0.1
12	Connecting piece	-	0
13	Outlet grill	-	0.15
14	Outlet grill (rotatable) 50 dia.	-	0.15
	Regulating valve 60x60x60 dia. with flap		
15	Position "middle"	-	0
	Position "right/left"	-	1
	Heating air ducting with reduction hood 75 dia. (heater rating 15)		
16	Pipe bend, 75 dia.	2	2*
17	Flexible pipe, 75 dia., per m	1	0.25
-	90° pipe bend of flex. pipe, 75 dia.	0.7	0.15
18	T-piece 75x75x75 dia.	-	0.7
19	Grille, 75 dia.	0.3	0
20	Connecting socket, metal, 75 dia.	0	0
21	Outlet grill (rotatable) 75 dia.	0.7	0.15
	Regulating valve 75x75x75 dia. with flap		
22	Position "middle"	-	0
	Position "right/left"	-	1
23	Y-piece 50x75x50 dia.	-	1.3
24	Reducing piece, 75 dia. - 50 dia.	-	0.8
25	Flexible pipe, 50 dia. per m	-	1
-	90° pipe bend of flex. pipe, 50 dia.	-	0.8
26	Outlet grill (rotatable) 50 dia.	-	0.35
27	Connecting socket, plastic, 50 dia.	-	0
28	Reduction hood, 75 dia.	0	0
29	Silencer, 75 dia.	1	-
30	Connector, 75 dia.	-	-

* Component is in front of the 2-duct system. In the case of a combination of air-ducting parts - dia. 60 at the intake side and dia. 75 at the exhaust side - the rating of the components at the exhaust side must be multiplied by 0.4. The heating rating 6 applies.

8 DUCTING RATING GUIDE

REVISION LEVEL A - 09/09/15

DUCTING RATING GUIDE FOR AIRTRONIC 5

Heater Rating 10.

The sketch shows how the most important air ducting parts that can be used. They are not intended as examples of installation.

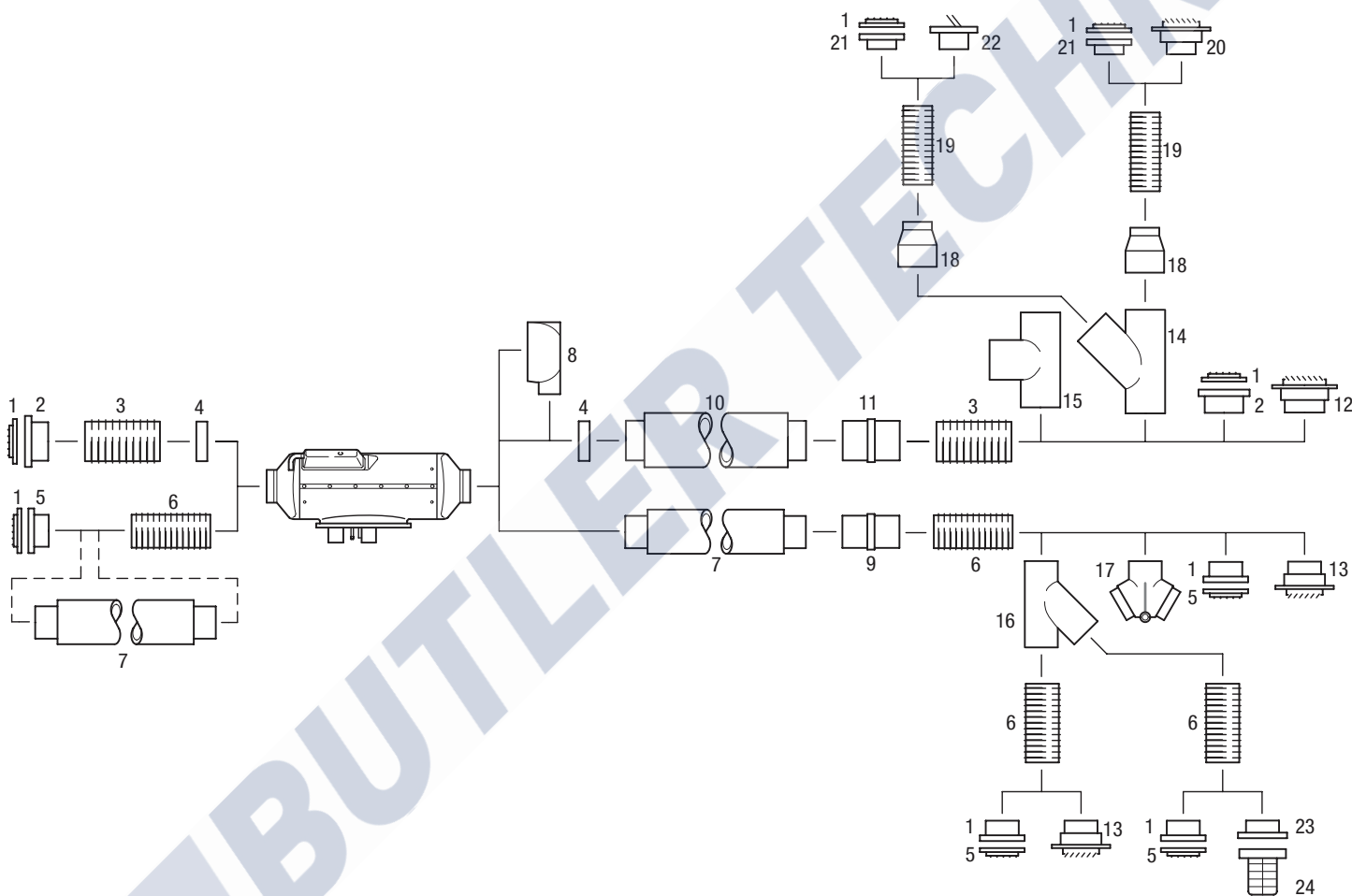



8 DUCTING RATING GUIDE

REVISION LEVEL A - 09/09/15

DUCTING RATING GUIDE FOR AIRTRONIC 5

	DESIGNATION (measurements in millimeters)	COMPONENT RATING	
		1-duct	2-duct
	Heating air ducting with reduction hood 60 dia. (heater rating 6)		
1	Grille	0.6	0.2
2	Connecting socket, metal, 100 dia.	0	0
3	Flexible pipe, 100 dia. per m	0.6	0.2
	Bend, 90° of flexible pipe, 100 dia.	0.6	-
4	Grille, 90x100 dia.*	0	-
5	Connector piece, 90 dia.	0	0
6	Flexible pipe, 90 dia. per m	1.0	0.25
	Bend, 90° of flexible pipe, 90 dia.	0.2	-
7	Silencer, 90 dia.	0.8	-
8	Spherical reduction hood, 90 dia.	8	-
9	Connector, 90 dia.	0.5	0.1
10	Silencer, 100 dia.	0.5	-
11	Connector, 100 dia.	0.4	0.1
12	Outlet grill (rotatable) 100 dia.	2	0.5
13	Outlet grill (rotatable) 90 dia.	2	0.5
14	Y-piece 100x100x100 dia.	-	0.5
15	T-piece 100x100x100 dia.	-	0.5
16	Y-piece 90x90x90 dia.	-	0.6
	Regulating valve 90x90x90 dia.		
17	Position "middle"	-	1.1
	Position "right/left"	1	-
18	Reduction piece, 100 dia. - 75 dia.	3.2	-
19	Flexible pipe, 75 dia. per m	4	1
	Bend, 90°- of flexible pipe, 75 dia.	-	0.5
20	Outlet grill (rotatable) 75 dia.	-	1.25
21	Connecting socket, metal, 75 dia.	0	0
22	Round outlet, 75 dia., closing	-	-
23	Connector, 90 dia.	0	0
24	Outlet grill	3	0.8

* Pos. 4 - if used as adapter 90 x 100 dia., cut out the mesh.

8 DUCTING RATING GUIDE

REVISION LEVEL A - 09/09/15

DUCTING RATING GUIDE FOR D8LC

Heater Rating 8

The sketch shows how the most important air ducting parts that can be used. They are not intended as examples of installation.

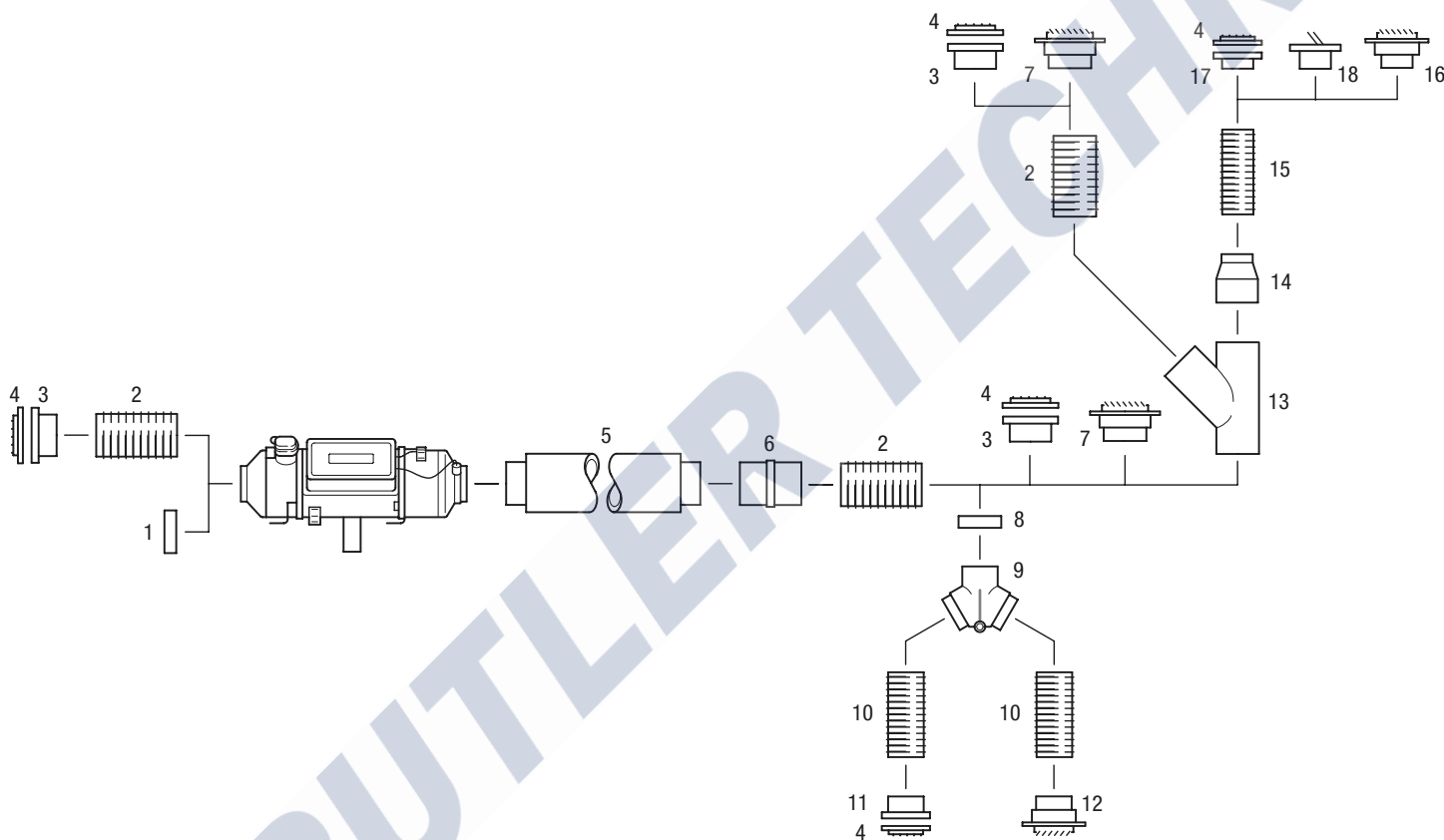



8 DUCTING RATING GUIDE

REVISION LEVEL A - 09/09/15

DUCTING RATING GUIDE FOR D8LC

	DESIGNATION (measurements in millimeters)	COMPONENT RATING	
		1-duct	2-duct
	Heating air ducting with reduction hood 100 dia. (heater rating 8)		
1	Grille, 100 dia.	0.1	-
2	Flexible pipe, 100 dia., per m	1.0	0.25
-	Pipe bend, 90°, of flex. pipe, 100 dia.	0.5	0.15
3	Connecting socket, metal, 100 dia.	0	0
4	Grille, painted, 100 dia.	1.8	0.1
-	Grille, nickel-plated, 100 dia.	1.8	0.1
5	Silencer, 100 dia.	1.1	0.25
6	Connector socket, 100 dia.	0.5	0.1
7	Outlet grill (rotatable), 100 dia.	5.5	1.2
8	Grille, 90x100 dia.*	0	-
9	Regulating valve 100x100x100 dia.	-	2.6
10	Flexible pipe, 90 dia., per m	3	0.8
11	Connecting socket, metal, 90 dia.	0	0
12	Outlet grill (rotatable) 90 dia.	-	1.4
13	Y-pipe 100x100x100 dia.	-	0.4
14	Reduction piece, 100 dia. - 74 dia.	6.1	-
15	Flexible pipe 75 dia. per m	-	2
-	Pipe bend, 90° of flex. pipe, 75 dia.	-	1.1
16	Outlet grill (rotatable) 75 dia.	-	-
17	Connector socket, 75 dia.	0	0
18	Connecting socket, metal, 75 dia.	-	-

*Pos. 8 - if used as adapter 90x100 dia., cut out the mesh.

BUTLER TECHNIK



Eberspächer